

Digitized by the Internet Archive
in 2022 with funding from
Kahle/Austin Foundation

Books by the Same Publishers

DICTIONARY OF GEMS AND GEMOLOGY

Robert M. Shipley

INTRODUCTORY GEMOLOGY

Robert Webster and Virginia V. Hinton

THE STORY OF DIAMONDS

A. C. Austin, Marion Mercer and Robert M. Shipley

FAMOUS DIAMONDS OF THE WORLD

Robert M. Shipley

JEWELERS POCKET REFERENCE BOOK

Robert M. Shipley

in preparation

DICTIONARY OF DIAMONDS

Robert M. Shipley

HANDBOOK OF GEM IDENTIFICATION



Characteristic silk-like inclusions are shown in a photomicrograph of demantoid garnet.

See pages 82-83.

Frontispiece

HANDBOOK OF
GEM
IDENTIFICATION

by

RICHARD T. LIDDICOAT, JR.,

Director of Education

GEMOLOGICAL INSTITUTE OF AMERICA

With a Foreword by

DEAN EMERITUS EDWARD H. KRAUS, PH.D., SC.D.

COLLEGE OF LITERATURE, SCIENCE AND THE ARTS
UNIVERSITY OF MICHIGAN

VOLUME 7 OF THE JEWELERS LIBRARY

Published by the

GEMOLOGICAL INSTITUTE OF AMERICA

541 South Alexandria Avenue, Los Angeles, California

QE 392

.L7

COPYRIGHT, 1947

BY THE

GEOLOGICAL INSTITUTE OF AMERICA

FIRST EDITION

SECOND PRINTING

1947

*All rights reserved. No part of this work may
be reproduced without the written permission
of the author and the publishers.*

PRINTED IN THE UNITED STATES OF AMERICA

Foreword

Today jewelers and the general public are better informed concerning gems than ever before. In the United States, this is due in large measure to the wide dissemination of gemological information during the last quarter of a century through the publication of authoritative texts on gems, the formation of many mineralogical clubs, and especially through the activities of the Gemological Institute of America, founded in 1931, and of the American Gem Society, organized in 1934. For some time, however, it has been recognized that there is need for a manual describing in detail the various methods and procedures to be followed in the identification of gems. This need is now being supplied by Richard T. Liddicoat's "Handbook of Gem Identification."

By his excellent scientific training and his extensive experience at the Gemological Institute of America, Mr. Liddicoat is well qualified to author an authoritative handbook. Moreover, he has had the benefit of the counsel and advice of Director Robert M. Shipley and others at the Institute.

In the opening chapters, the essentials concerning the important properties of gemstones are described in a lucid manner. Manufactured stones and the instruments used for testing are discussed in several chapters. The main portion of the book is devoted to the tests and procedures to be followed in the

Foreword

identification of gemstones, which are grouped according to color. As the tests and procedures are outlined in great detail, there should be no difficulty whatever in following them. The book also includes useful tables of properties, a glossary, and various flow charts.

This handbook should prove to be very helpful in the making of accurate determinations of gemstones. It is a valuable addition to gemological literature, and will be welcomed by dealers in, and lovers of, gems.

Edward H. Kraus.

Ann Arbor, Michigan
July 21, 1947

Preface

Although many books have been written describing gemstones and their occurrence, there is a need for books which give both the jeweler and the layman with limited equipment an outline for making the simple and often conclusive tests that identify gems. If properly used this handbook will help to fill that need.

Several individuals offered valuable assistance in the preparation of this book. From his initial suggestion, which started the preparation to the reading of the final proofs, Robert M. Shipley proved unfailingly helpful. The author is also especially indebted to Ralph J. Holmes, Ph.D., for his many suggestions. George Switzer, Ph. D., contributed several ideas that have been incorporated. Several of the adaptations of mineralogical instruments and tests for the identification of gemstones were developed by Robert Shipley, Jr. Many of the methods and tests used in this handbook were developed by him. The majority of the photomicrographs of gemstone inclusions are those of Dr. Edward Gubelin, C.G., of Lucerne, Switzerland, who kindly permitted their use. With few exceptions, the line drawings were prepared by Lester Benson.

TABLE OF CONTENTS

Chapter	Page
I Introduction	1
II The Nature of Gemstones	3
III Cleavage, Fracture, and Hardness	8
IV Specific Gravity	15
V Refractive Index Determination	25
VI Double Refraction, Pleochroism and Optic Character	41
VII Magnification	55
VIII The Use of Characteristic Imperfections as a Means of Gem Identification	71
IX Color Filters and Fluorescence	97
X Synthetic Gemstones	102
XI Doublets, Triplets, Foil Backs and Imita- tions	120
XII Pearls, Cultured Pearls and Imitations	129
XIII Instruments Essential to Gem Testing	141
XIV A Procedure for the Identification of Gem- stones and Their Substitutes	148
XV The Identification of Transparent Purple and Violet Gemstones and Their Substitutes	154
XVI The Identification of Transparent Blue Gem- stones and Their Substitutes	164
XVII The Identification of Transparent Green Gemstones and Their Substitutes	175
XVIII The Identification of Transparent Yellow Gemstones and Their Substitutes	186

Table of Contents

XIX	The Identification of Transparent Brown and Orange Gemstones and Their Substitutes	196
XX	The Identification of Transparent Pink and Red Gemstones and Their Substitutes	207
XXI	The Identification of Transparent Colorless Gemstones and Their Substitutes	219
XXII	The Identification of Nontransparent Blue Gemstones and Their Substitutes	229
XXIII	The Identification of Nontransparent Red, Yellow and Brown Gemstones and Their Substitutes	238
XXIV	The Identification of Nontransparent White, Gray and Black Gemstones and Their Substitutes	245
Appendix	253
Optic Character Table	254
Dispersion Table	255
Table of Birefringence	42 and 255
Refractive Index Table	39 and 256
Specific Gravity Table	24 and 258
Hardness Table	14 and 259
Property Table	260
Glossary	271
Index	275

Chapter I

Introduction

To successfully identify gemstones, firsthand familiarity with many of their properties and the tests for determining those properties is essential. Gems, being mostly varieties of mineral species, are more or less easily identifiable because each mineral has a fairly constant chemical composition, as well as physical and optical properties, which vary within rather narrow limits. Thus, by determining the characteristic properties of an unknown stone, it is possible to determine its nature without guesswork.

The first part of this book is devoted to the important properties of gems and to their identification by various instrument tests, with full explanation of methods and results. While in many instances positive identification can be made with the simplest of instruments, more difficult tests are also described in detail.

The remaining portion of the book is devoted to a detailed step-by-step plan to classify gemstones correctly in each of the different colors in which important gems occur, with a sufficiently wide color range to satisfy any indecision as to colors on the part of the tester. There are also chapters covering the distinction between gems of natural and synthetic origin. Means of identification of other substitutes also are included. Complete tables of the properties of important gems, as well as many infrequently encountered in the jewelry trade, are contained in the appendix. Tables of the properties of gems of the color under discussion, with the variability of each property, are contained in each chapter on identification.

Many photographs and drawings supplement the text in order to clarify the tests. Numerous photomicrographs illustrate the appearance of gems of natural origin, as well as the man-made counterparts. Characteristic inclusions of various gems are also portrayed in photomicrographs to assist in making identifications based on their characteristic internal appearance.

Chapters describing the important tests prepare the reader for the use of the final identification portion of the book. There are seven sections devoted to the identification of transparent gemstones and their substitutes; three to nontransparent gemstones and their substitutes; and one section to the identification of natural and cultured pearls, and pearl imitations. Each section on the identification of gemstones follows a pattern based upon the recommended procedure for gem testing. Gemstones and substitutes, which occur in the color range to which the section is devoted, are listed at the beginning. The tests which should be used to identify the gem follow in order, with each test dividing and subdividing the original list of possible gems in the color of the unknown stone. It is very rarely necessary to make all of the determinations in the procedure, since most gems are identified by the time a few tests have been made. The identification flow charts which follow each of the sections on the identification of transparent gemstones are included to assist the jeweler who has become proficient in the use of the various tests, so that reference to the remaining portions of the book is seldom required. The flow chart includes each test that should be made, as well as what is accomplished by the test.

Chapter II

The Nature of Gemstones

The Nature and Classification of Gem Minerals. With rare exceptions (amber, jet, pearl, and coral) the materials used for gem purposes are minerals. A MINERAL has been defined as a naturally occurring inorganic material of essentially constant chemical composition, usually possessing a definite crystal structure or orderly arrangement of its component atoms. Opal, which is generally regarded as amorphous; i.e., lacking a systematic arrangement of atoms, is an exception. Since each mineral species possesses a constant chemical composition and a characteristic crystal structure, it follows that each species will have a constant set of physical and optical properties. This constancy of properties renders the identification of gem materials possible. Amber and jet, although they occur within the earth, are not regarded as minerals since they have been produced through the agency of living organisms. To such organic materials the mineralogists have applied the term MINERALOIDS. A ROCK is a mechanical intergrowth of two or more minerals. Lapis lazuli, consisting of lazurite, pyrite and sometimes calcite, is an example of a gem that is regarded as a rock rather than a mineral.

Mineralogists, in their description of minerals, employ a classification just as zoologists and botanists do in describing animals and plants. Since almost all gems are minerals, gemologists follow the mineralogical classification. Botanists and zoologists refer to genera, species and varieties of plant and animal life. The gemologist and mineralogist use the terms, GROUP, SPECIES and VARIETY. GROUP refers to two or more gem minerals that

are similar in structure and properties, but not quite the same chemically. The individual members of a group are themselves SPECIES. All VARIETIES of a species have the same crystal structure, and the same chemical composition, but differ only in color. The color variations are usually due to the presence of minute traces of impurities. Thus, ruby and sapphire are color varieties of the gem mineral corundum. The garnet family is classed as a gemological group, since there are appreciable differences in the composition of the several types of garnet although all members of the group are identical in structure. The difference in color among the members of the garnet group is not due to small quantities of impurities (as in the case of ruby and sapphire), but is directly attributable to the basic chemical differences between the species of the garnet group.

Crystal Systems and Their Function in Determinations. The optical, physical, and all other properties of a mineral, are determined by its chemical composition and crystal structure. Minerals having a definite crystal structure are called crystalline, while those with no regular internal arrangement are known as amorphous. One of the few natural amorphous substances used as a gem is opal, but glass and several other imitations are also amorphous. All crystalline materials are assigned to one of the six different crystal systems, each mineral species occurring in only one of those systems. The crystal systems are: isometric (or cubic); hexagonal; tetragonal; orthorhombic; monoclinic; and triclinic. Diamond and spinel crystallize in the isometric system. Beryl (emerald and aquamarine) and corundum (ruby and sapphire) crystallize in the hexagonal system. Zircon crystallizes in the tetragonal system. Gems crystallizing in the orthorhombic system are topaz and chrysoberyl. Commonly encountered monoclinic gems are the jades and precious moonstone (orthoclase feldspar). Gems that crystallize in the triclinic system are turquoise and labradorite feldspar.

Differences in chemical composition and internal structure

The Nature of Gemstones

give the various gems properties that differ from each other markedly, and thus enable the jeweler to identify the various species. Gems that crystallize in the isometric system and those that are amorphous are known as isotropic; that is, they are singly refractive. Gems that crystallize in the other five crystal systems are doubly refractive; i.e., they possess the property of breaking up a beam of light into two rays as it passes through the substance.

Knowledge of the crystal system of a gem is important because many of the properties used in identification are related to the crystallization of the material. Familiarity with crystal forms and habits is also a valuable aid in the identification of rough gem materials. On the basis of the optical properties of a cut gem, it is often possible to decide in which system or group of systems the gem belongs. The determination of the nature of common crystal inclusions in faceted gems provides a valuable clue to their identity. Since the shapes of small crystal inclusions seen within liquid inclusions in Colombian and Uralian emeralds are different, the trained observer is able to determine the source of the gem by recognizing the crystal form of these inclusions. Genuine spinel, for example, is characterized by minute octahedral inclusions. Any mineralogical or gemological text contains diagrams which will assist in determining the crystal system of rough gems.

Crystal Structure. Variations in chemical composition and crystal structure of gem minerals cause a wide range of physical and optical properties. The heavier the individual atoms, the greater will be the density of the material. Likewise, spacing of atoms within the structure will influence densities. Diamond and graphite are both carbon, but the density of graphite is only slightly more than half that of the diamond. This is a consequence of the extremely closely packed structure of diamond. This tightly packed structure of the diamond also accounts for its extreme hardness.

Identification of Unknowns. Since each mineral species has characteristic and fairly constant optical and other physical properties, it follows that the determination of these properties will make possible the identification of a gem of unknown nature. There are many properties that may be used to separate the various species, but the ease with which the several properties can be determined varies considerably. Dispersion is a difficult property to measure, but it can be determined. Resistance to fracture or to chemical corrosion are not only difficult to evaluate, but will cause damage to the gem by their application. Unlike the mineralogist, the gemologist is severely limited in the tests which can be applied to gem identification. Many of the principal methods of mineral identification require the partial destruction of the sample. The gemologist is obviously limited to the use of tests that will in no way harm the specimen, yet they must be conclusive and rapid. The tests that best fulfill the gemologist's requirements are those for refractive index, single or double refraction, pleochroism, specific gravity, and characteristic inclusions. The first four have long been the basis of gem identification.

Identification of the various natural gem species is based on accurate determination of optical and physical properties. Prior to the advent of the synthetic gemstone, no further tests were necessary to conclusively identify any gem. The introduction of the synthetic has greatly increased the difficulty of accurately identifying gem minerals, since by definition, not only the chemical composition but the crystal structure of a synthetic must be identical with that of the natural gem which it represents. As a consequence of this identity of composition and structure, the optical and physical properties of both the natural stone and its synthetic equivalent are essentially identical. Therefore the determination of the constant optical and physical properties does not distinguish between natural stones and their synthetic counterparts. Fortunately, the inclusions found in man-made gems are different from those found in gems of natural origin. In many instances, however, the synthetic gem

The Nature of Gemstones

is sufficiently well made to require high magnification to resolve its inclusions. Inasmuch as it is often necessary to examine gems under high magnification, the use of characteristic inclusions to distinguish between natural gem species as well as between artificial and natural gems is of great value to one who has become familiar with their appearance.

Chapter III

Cleavage, Fracture, and Hardness

Cleavage. The atomic pattern of a gemstone and the relative strength of the bonds between atoms determines the manner in which the stone may break or split. **CLEAVAGE**, which might be compared to the splitting of wood along the grain, is a gemstone's tendency to split along directions parallel to certain planes of atoms in its internal structure; it is dependent on the lack of cohesion between atomic planes in certain directions. Cleavage within a gem results in a flat, smooth break, and is described both by its relation to the crystal faces, or possible crystal faces, of the original crystal and by the ease with which the splitting occurs. The cleavage of diamond is parallel to the octahedral faces; its most common crystal form. The cleavage of topaz is described as perfect parallel to the base of its prismatic crystal form.

Since few gemstones are likely to cleave, presence of cleavage cracks within a gem may be of valuable assistance in its identification. **GEMS WHICH CLEAVE EASILY ARE:** diamond, the feldspars, spodumene (kunzite), and topaz. Beryl, garnet, quartz and zircon do not cleave readily.

The presence of cleavage in a gem is proof that the material is crystalline and is an indication of importance to the gem cutter, who must both utilize cleavage and guard against it in his work.

False Cleavage (Parting). A flat smooth break that occurs parallel to planes of weakness caused by repeated twinning is

Cleavage, Fracture and Hardness

called parting or false cleavage. It is not uncommon in ruby and sapphire.

Fracture. Fracture, which may be compared to splitting across the grain of a wood, takes several forms which are described by their distinctive appearance. The following are the most common:

Conchoidal fracture presents a curved and shell-like appearance. Most gems show conchoidal fracture — glass perhaps to a greater extent than genuine stones.

Even fractures have a smooth appearance, but lack the regularity and single-plane appearance of cleavage.

Some types of quartz show even fracture.

Uneven fractures can best be described by likening them to the edges of broken pottery.

Almost any mineral or rock exhibits uneven fracture.

Splintery fractures resemble the usual breaks seen in wood.

Splintery fracture is seen most often in hematite and in nephrite jade.

Fracture is of little use in identification, with two notable exceptions:

(1) Chalcedonic quartz has the shell-like fracture common to most gems, but the luster on such fracture surfaces is dull, not vitreous as in other gemstones.

(2) Hematite may be distinguished from substitutes such as Hemetine* by its splintery fracture.

Hardness. The property of hardness, dependent upon cohesion, or the forces of attraction between atoms, may be simply defined as a material's resistance to scratching or abrasion. Since each gem has a characteristic hardness, the test for hardness often reveals a valuable clue to the identity of a gemstone. The possibility of damage to the stone, in the case of transparent gemstones, seriously limits the value of the test. In the determination of opaque gemstones, on the other hand, the test is often essential.

Mohs' scale, the standard scale of hardness in both mineralogy and gemology, comprises the following minerals arranged in order of decreasing hardness:

*Trademark.

HANDBOOK OF GEM IDENTIFICATION

10 Diamond	5 Apatite
9 Corundum	4 Fluorite
8 Topaz	3 Calcite
7 Quartz	2 Gypsum
6 Feldspar	1 Talc

The following intermediate values, supplementary to the figures given by Mohs, are useful in gemstone identification:

8½ Chrysoberyl
7½-8 Beryl
7½ Almandite garnet, zircon

In addition, several man-made materials are commonly utilized, such as carborundum 9¼, steel file 6-7, window glass 5½, copper penny 3.

In making a hardness test, the jeweler should bear in mind that a gem of any given hardness will scratch another gem of equal hardness.

Hardness Testing of Transparent Gemstones. The test should preferably be made upon the back of the stone. Since the back of a mounted gem near the girdle is not visible, a scratch from the hardness points or plate edges on the back will not detract from the beauty of the stone.

Caution: Hardness tests must be applied to transparent gemstones with great care. When other tests have narrowed the identification to one of two or three of the fragile gems, the chance of fracture or cleavage from the hardness test is too high to risk its use. In the identification of transparent gemstones the hardness test must be regarded as a last resort, to be used only when no other test remains from which to draw a conclusion.

Preferred for the test applied to transparent gemstones are **HARDNESS PENCILS, OR POINTS**, which are usually made of tubular steel with the hardness point set into the tube and ground to a fairly sharp point. As a rule, only points of hardness greater than 5 are used, since these encompass the gem range.

If it is evident that the material may be glass, the hardness test may be made with a broken-ended **STEEL FILE**, which has a

Cleavage, Fracture and Hardness

hardness of 6 to 7, is tough, will scratch glass, and usually has sharper edges than hardness points.

If there are indications that the gemstone is one of the tougher transparent varieties, **HARDNESS PLATES** are often used for the test. These plates are small, polished rectangular pieces of the minerals listed in the Mohs scale.

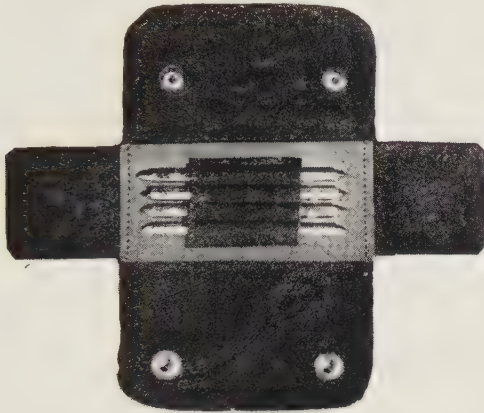

Figure 1

Set of eight hardness points, with points of hardness five to ten.

To Make the Test with a Hardness Pencil or Point:
With a gentle but firm touch, to avoid damage to the stone, apply



Figure 2

Correct position and length of scratch on faceted gemstone.

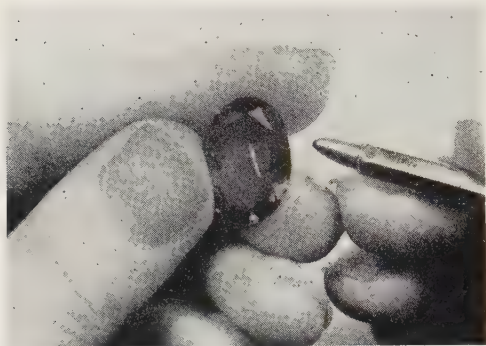

Figure 3

Incorrect hardness test—poorly placed and much too long.

the point to one of the back facets of the gem, as near the girdle as possible. Only a very short scratch is necessary. Wipe the gem carefully and examine it under the loupe to see whether the hardness point powders against the gem or actually makes a scratch.

It is often possible to apply the point along the relatively rough girdle of the gem, which offers a better testing surface and one on which the scratch may be hidden by the mounting.

To make the Test with a Hardness Plate: In any test with hardness plates, start with the softer plates first, beginning with hardness 4 or 5. Attempt to scratch the hardness plate with the edge of the gem.

Caution: Since in testing gems in this manner against the plates of greater hardness a perceptible portion of the girdle might easily be ground down, and since the edges of the harder plates are usually sufficiently sharp to be used as hardness points, it is advisable to apply them as such against the back of the gem to avoid damage to the girdle.

The Hardness Test Applied to Opaque Gemstones. Since fewer tests are available for the identification of opaque gemstones than can be applied to transparent gems, the jeweler

Cleavage, Fracture and Hardness

must often resort to the hardness test for a determination. Although either hardness pencils or plates may be used, hardness plates are often more helpful in testing opaque materials.



Figure 4

Hardness testing with a hardness plate.

To Make the Test with Either Hardness Pencils or Plates: Proceed according to the directions given for each in the preceding paragraphs. Less care is needed, since scratches on the back of the opaque gem are not visible in the mounting.

HANDBOOK OF GEM IDENTIFICATION

Hardness Table. The following hardness table includes all of the gemstones a jeweler is likely to encounter:

RELATIVE HARDNESS OF GEM MINERALS*

HARDNESS: The resistance a gem offers to being scratched. Figures are relative, not absolute. Based upon Mohs' Scale of Hardness.

DIAMOND	10	LABRADORITE	
CORUNDUM	9	FELDSPAR	6
CHRYSOBERYL	8½	Hematite	5½-6½
SPINEL	8	Anatase	5½-6
TOPAZ	8	Beryllonite	5½-6
BERYL	7½-8	Nephelite	5½-6
Phenacite	7½-8	Moldavite	5½
ZIRCON	7½	Brazilianite	5½
ALMANDITE GARNET	7½	Enstatite	5½
Euclase	7½	Willemite	5½
PYROPE GARNET	7-7½	OPAL	5-6½
TOURMALINE	7-7½	Diopside	5-6
Iolite	7-7½	Lazulite	5-6
Andalusite	7-7½	LAPIS LAZULI	5-6
Spessartite garnet	7-7½	TURQUOISE	5-6
GROSSULARITE		Bowenite (serpentine)	5-5½
GARNET	7	Obsidian	5-5½
QUARTZ	7	Datolite	5-5½
CHALCEDONY		Sphene	5-5½
QUARTZ	6½-7	Thomsonite	5-5½
PERIDOT	6½-7	Apatite	5
JADEITE JADE	6½-7	Diopase	5
ANDRADITE GARNET	6½-7	Smithsonite	5
Axinite	6½-7	Kyanite	4-7
Idocrase	6½	Variscite	4-5
Scapolite	6½	Diallage	4
SPODUMENE	6-7	Fluorite	4
Sillimanite	6-7	Azurite	3½-4
Epidote	6-7	Malachite	3½-4
Benitoite	6-6½	CORAL	3½
Pyrite	6-6½	JET	3-4
Rutile	6-6½	Calcite	3
MICROLINE		Serpentine	2½-4
FELDSPAR	6-6½	PEARL	2½-4½
ORTHOCLASE		Chrysocolla	2-4
FELDSPAR	6-6½	AMBER	2-2½
NEPHRITE JADE	6-6½	Steatite (soapstone)	1-2½

*Important gemstones are indicated by capital letters.

Chapter IV

Specific Gravity

Value in Identification. One of the most definitive tests available to the gem tester is the accurate measurement of specific gravity. Despite its usefulness as a means of distinguishing between gemstones, few jewelers attempt to determine specific gravity. Since the measurement is easily made with equipment found in the average jewelry store, it should be a basic tool in gem identification.

Density and Specific Gravity. DENSITY is defined as the mass of any given material per unit volume. It is dependent upon the atomic weight or weights of the constituents and upon the atomic spacing of the material. Thus, the mass or weight of lead in one cubic foot greatly exceeds that of an equal volume of wood. Diamond is composed entirely of carbon, an element with a very low atomic weight. The relatively close atomic spacing of diamond, however, gives that gem a medium density. Both the silicon and the oxygen atoms of quartz have atomic weights greater than carbon, but its less compact crystal structure produces a smaller mass per unit volume.

The fact that one substance has a greater density than another is of little value in gem identification, unless a means of making exact comparisons is available. To make exact comparisons, it is necessary to compare the weights of equal volumes of materials. Since gems are seldom of the same size, their volumes must be determined first. The ratio of the weight of a gemstone to the weight of an equal volume of water gives a figure that can be compared to a similar value for any other gemstone. This ratio is called SPECIFIC GRAVITY. It is more accurately defined as

the ratio of the weight of a substance to the weight of an equal volume of water at 4° Centigrade (the temperature at which density of water is the maximum). The variation of water's density from 4° to room temperature is so slight that it need not be considered in gem identification.

Comparing diamond to an equal volume of water, we find that diamond, for example, weighs 3.52 times as much as the water. Amber is only 1.08 times as heavy as water in equal volume, while gold is 19.3 times heavier than water.

The specific gravity of each gem species is constant within fairly narrow limits. In a few instances, the specific gravity of two species will be nearly the same, or will overlap, but such instances are exceptional. It is therefore apparent that specific gravity can be used as a valuable clue to the identity of a gem.

The Hydrostatic Principle. To make a specific gravity determination, it is necessary to compare the weight of a gemstone to that of an equal volume of water. It might appear that it would be difficult to determine what constitutes an equal volume of water. The famed philosopher and scientist, Archimedes, determined that any material wholly immersed in water loses in weight an amount equal to the weight of water it displaces. Since a gem must displace a volume of water equal to its own volume, the weight of an equal volume of water must equal the stone's loss of weight when immersed in water.

Thus, if a gem is first weighed in air, then weighed when immersed in water, the difference in the two weights must be the weight of the water displaced — an amount of water which is equal in volume to the gem. Then the weight of the gem in air divided by the loss of weight when weighed in water must, by definition, be its specific gravity.

The Adaptation of the Jeweler's Diamond Balance for S. G.* Measurements. The diamond balance can easily be adapted to secure specific gravity measurements. A stand is placed so that its base rests under the weighing pan of the balance, and its arm extends up over the pan so that a water container can be placed over the pan, without touching the balance.

**Specific gravity.*

Specific Gravity

A wire is suspended from the arm of the balance which holds the weighing pan, so that it hangs into the liquid in the container which rests on the stand.

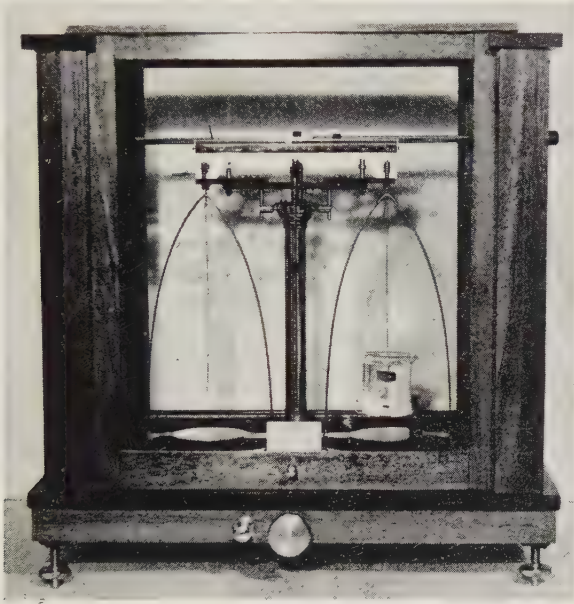

Figure 5

Jeweler's diamond balance with specific gravity attachments.

The end of the wire that hangs into the water is bent into a loop or basket that will hold the gem to be tested. From the opposite arm of the balance a second wire is hung to act as a counterbalance to the wire suspended in the water. For the purpose of simplifying the calculation of specific gravity, the second wire should exactly balance the first, when the first wire is suspended in the water.

Use a longer wire for the counterbalance to the wire that holds the stone. Reduce the counterbalance in length very carefully, until it balances the wire which hangs into the liquid. This eliminates the necessity for taking into account the weight of the wire that holds the stone.

Sample Specific Gravity Determination by Means of a Diamond Balance. After having balanced a wire hanging in water on one side of the balance with a wire hanging in air on the other side, we make the following determinations:

The weight of a gem in air is four carats. Its weight in water is three carats. Using the formula,

$$\frac{\text{Weight in air}}{\text{Weight in air} - \text{weight in water}} = \text{Specific gravity}$$

$$\text{we have } \frac{4}{4-3} = \text{Specific gravity} = \frac{4}{1} = 4.0.$$

The Use of "Carbona." When specific gravity is determined by means of the diamond balance, the surface tension of the water dampens the swing of the balanced wire loop basket so much that it is often difficult to obtain accurate determinations on small gems. To reduce the surface tension of water effectively, add a detergent, such as "Dreft" or "Vel" for which no extra computation need be made.

Jewelers often substitute the commercial form of carbon tetrachloride called "Carbona" in place of pure water to avoid the high surface tension problem. If this substitution is made, the tester must make allowance for the density of "Carbona" (1.59) in the formula for obtaining specific gravity.

Thus, when weighing a gemstone in "Carbona" the formula is:

$$\frac{\text{Weight in air}}{\text{Weight in air} - \text{weight in liquid}} \times 1.59 = \text{Specific gravity}$$

Using the same example as that in which the weighing was taken in water, this change would be necessary: The weight of the stone in air was 4 carats; its weight in "Carbona" would be 2.41 carats. Inserting these figures in the above equation, we have the result:

$$\text{S.G.} = \frac{4}{4 - 2.41} \times 1.59 = \frac{4}{1.59} \times 1.59 = 4.0.$$

Because of its very low surface tension, specific gravity determinations made with "Carbona" are usually more accurate than when water is used, despite the extra computation.

Specific Gravity



Figure 6

Specific gravity determination on a jeweler's diamond balance.

Other Balances. There are several balances which utilize this hydrostatic method of specific gravity determination. One, the Berman, is a torsion balance. The important advantage of the Berman Balance is its accuracy with gems of less than one-third carat. The Berman is not commonly used in the jewelry trade, since it cannot be used for weight determination, and it is more expensive than an accurate diamond balance.

The Jolly Balance is occasionally used to determine the specific gravity of rough minerals and gems over five carats in size. It consists of a tall mirror, with a calibrated scale beside it, from the top of which hangs a long coiled spring from which are suspended two small pans. A zero reading of the scale is taken with the lower pan in water and the upper pan empty. Then readings are taken with the stone first on the pan in the air, and again on the lower pan, which is submerged in water. The reading taken with the stone on the upper pan subtracted from the zero reading is divided by the difference between the reading taken with the stone on the upper pan and the reading with the stone on the submerged pan. If a

Figure 7

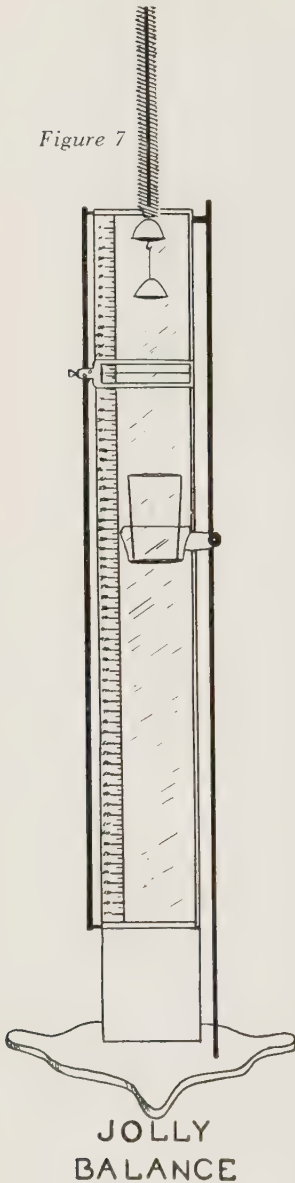

detergent is used in the water, the specific gravity determinations are fairly accurate with stones of two to three carats.

Direct Reading Balances—Such scales as the Westphal Balance and the Penfield Balance (as well as its modifications) determine specific gravity directly. The balances mentioned have a zero setting against which the stone is weighed in air. The stone is then weighed in water with a direct reading of specific gravity the result. These balances are so designed that the second reading gives specific gravity rather than a second weight.

The Use of Estimator Gauges for Specific Gravity Approximations. A method for the approximation of specific gravity is provided by the Moe Gauge or the A. D. Leveridge Millimeter Gauge. Such gauges, and the tables which accompany them, are normally employed for the estimation of the weights of brilliant-cut diamonds only; the Leveridge tables include estimations for the weight of step-and marquise-cut diamonds. To determine specific gravity roughly, measure the girdle diameter and the depth from culet to table of the unknown stone, and estimate its weight from the tables as if it were a diamond. Now weigh the stone in

Specific Gravity

air. An approximation of the specific gravity of the gemstone may be obtained by using the following formula:

$$\frac{\text{Weight estimated from gauge tables}}{\text{Actual weight of the gem}} \times 3.52^* = \text{Approximate specific gravity}$$

Thus if the weight estimated from the tables were 2 carats and its actual weight were 2.5 carats, the approximate specific gravity of the gem would be

$$\frac{2}{2.5} \times 3.52 = 2.81$$

Since this method gives only an approximate specific gravity value, little reliance can be placed on the results obtained.

Liquids Used in Specific Gravity Determinations.

The most rapid specific gravity determination is obtained by means of heavy liquids. Of the several liquids which may be used, the most practical are methylene iodide, bromoform, and carbon tetrachloride. METHYLENE IODIDE is light yellowish brown when fresh, but becomes darker, as iodine is set free by sunlight (a small piece of pure tin in the liquid prevents discoloration). In its pure form it has a density of 3.32 at room temperature.

BROMOFORM, a colorless liquid, gradually turns yellow on exposure to sunlight as free bromine is released. Its density at room temperature is 2.9.

To determine the specific gravity of an unknown gemstone, using either methylene iodide or bromoform, place the gemstone gently in the liquid. *If the gem floats* it has a specific gravity less than that of the liquid, and the volume of the stone which remains beneath the surface of the liquid represents a volume of liquid equal in weight to the total weight of the stone. If 5/6 of a gem floating on a liquid beneath the surface, the gem's specific gravity is 5/6 that of the liquid. If a small transparent glass beaker is used for this determination it is possible to arrive at a fairly accurate estimate of the proportion of the stone which is below surface. *If the gem sinks slowly*, its specific

*3.52 is the specific gravity of diamond.

gravity is just greater than that of the liquid. *If it sinks very rapidly*, like a rock in water, the specific gravity is appreciably greater than that of the liquid.

Both bromoform and methylene iodide may be diluted with toluene to produce liquids of lower density. Methylene iodide is often diluted to a density of 3.1, about that of tourmaline, and bromoform to 2.68 — a liquid in which beryl sinks slowly, and quartz just floats. Pure methylene iodide may be used to distinguish quickly between topaz and tourmaline, since topaz sinks (specific gravity 3.53) and tourmaline floats (specific gravity 3.06).

Clerici's Solution. Clerici's solution is a mixture of thallium formate and thallium malonate which has a density between 4.2 and 4.3 at 70°F. It is a transparent liquid that is miscible with water. In the pure form of this liquid almost all transparent gems, with the exception of zircon, will float. Because of its miscibility with water, solutions of almost any density below 4.25 are easily made.

Caution! Clerici's solution is very poisonous and highly corrosive.

The Diffusion Column. The jeweler who plans to have three to six specific gravity liquids, with pure and diluted solutions, will usually find that six small glass-stoppered bottles of the wide-mouth variety will be most practical, though some will prefer the diffusion column method.

A diffusion column is made by putting high density liquid at the bottom of a fairly tall cylinder and carefully adding lower density liquids, one above the other, with each liquid slightly lower in density than the one below it.

By using known gems as indicators, the specific gravity at various points in the column is made evident. If a column has a density that starts at the bottom with pure Clerici's Solution at 4.15 and goes in successive steps to 3.9, 3.7, 3.5, 3.32, 3.1, 2.9 and 2.7, the specific gravity of a gem can be determined by noting where its downward fall into the liquid is stopped.

Corundum with a specific gravity of 4.0 would fall almost to

Specific Gravity

the bottom of the column; diamond would go almost to the topaz used as an indicator (just below 3.5 density); while quartz, with a specific gravity of 2.66, would barely float on the surface of the topmost liquid.

The specific gravity of gemstones is sufficiently constant to provide the gem tester with an important means of identification. It is not difficult to determine specific gravity by a variety of inexpensive but efficient methods. It provides an important means of gem identification.

HANDBOOK OF GEM IDENTIFICATION

SPECIFIC GRAVITY TABLE

Important gemstones are listed in capital letters.

Cassiterite	6.95(±.08)	Fluorite	3.18(±.01)
Hematite	5.20(±.08)	Apatite	3.18(±.02)
Pyrite	5.00(±.10)	SPODU-	
Marcasite	4.80(±.10)	MENE	3.18(±.03)
ZIRCON		Andalusite	3.17(±.04)
(alpha, beta)	4.70(±.03)	TOUR-	
Smithsonite	4.30(±.10)	MALINE	3.06(±.05)
Rutile	4.25(±.05)	Euclase	3.10(±.01)
Spessartite		Lazulite	3.09(±.05)
garnet	4.15(±.03)	Danburite	3.00(±.01)
ALMANDITE		NEPHRITE	
GARNET	4.05(±.12)	JADE	2.95(±.05)
Sphalerite	4.05(±.02)	Phenacite	2.95(±.01)
ZIRCON		Brazilianite	2.94
(gamma)	4.00(±.07)	Aragonite	2.94(±.02)
CORUNDUM	4.00(±.05)	Beryllonite	2.85(±.02)
Malachite	3.95(±.15)	TUR-	
Celestite	3.90	QUOISE	2.76(−.15, +.08)
Anatase	3.88(±.05)	Steatite	2.75
ANDRADITE		LAPIS	
GARNET	3.84(±.03)	LAZULI	2.75(−.20, +.07)
Rhodolite		BERYL	2.72(−.05, +.12)
Garnet	3.84(±.10)	PEARL	2.70(−.02, +.15)
Azurite	3.80(±.07)	Calcite	2.71(±.01)
PYROPE		LABRADORITE	
GARNET	3.78(±.09)	FELDSPAR	2.70(±.02)
CHRYSO-		Scapolite	2.70(±.03)
BERYL	3.73(±.02)	QUARTZ	2.66(±.01)
Benitoite	3.64(±.03)	OLIGOCLASE	
GROSSULARITE		FELDSPAR	2.65(±.02)
GARNET	3.61(−.04, +.12)	CORAL	2.65(±.05)
Kyanite	3.60(±.05)	CHALCEDONIC	
SPINEL		QUARTZ	2.61(±.03)
Dark blue	3.60(−.03, +.30)	Nephelite	2.60
Red, violet	3.60(−.03, +.30)	Serpentine	2.57(±.06)
Rhodonite	3.53(±.11)	ORTHOCLASE	
TOPAZ	3.53(±.04)	FELDSPAR	2.56(±.01)
DIAMOND	3.52(±.01)	MICROCLINE	
Sphene	3.52(±.02)	FELDSPAR	2.56(±.01)
Idocrase	3.40(±.06)	Variscite	2.50(±.08)
Epidote	3.40(±.08)	Obsidian	2.45(±.10)
PERIDOT	3.40(±.08)	Lazurite	
JADEITE		(pure)	2.40
JADE	3.34(±.04)	Moldavite	2.40
Diopside	3.30(±.05)	Sodalite	2.24
Dumortierite	3.30(±.05)	Chrysocolla	2.20(±.10)
Kornerupine	3.30(±.05)	OPAL	2.15(±.08)
Diopside	3.29(±.03)	Meerschaum	
Axinite	3.29(±.02)	(sepiolite)	2.00
Enstatite	3.25(±.02)	JET	1.30(±.02)
Sillimanite	3.24(±.02)	AMBER	1.08(±.02)

Chapter V

Refractive Index Determination

When a beam of light strikes the boundary surface between two transparent substances, such as between diamond and air, it is partly reflected. The law of reflection states that the *angle of incidence and the angle of reflection are equal and that the incident and reflected rays are in the same plane which is normal to the surface.* The reflection of an object in a mirror (Figure 8 illustrates this law.)

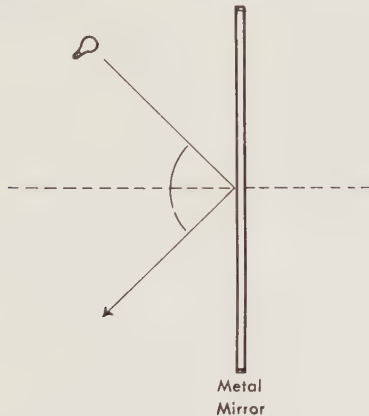

Figure 8

Reflection of a beam of light from a metal mirror.

Refraction. When a beam of light passes from air into another transparent material such as a gem, its velocity is reduced, and the beam is bent unless it strikes the surface of the material perpendicularly (at 90° to the surface). The ratio of the velocity of light in air to its velocity in the new substance is known as the

refractive index of that substance. Light passing obliquely from air into an optically denser substance is bent toward the normal. The *normal* is an imaginary line perpendicular to the surface. (See Figure 9.) Light coming from a denser substance into air is bent away from the normal.

If light passes from one medium into another of unequal optical density in a direction perpendicular to their boundary, no deflection of the light takes place. Light that passed from a gem into air along a path parallel to X-X' in Figure 9 would travel at an increased velocity in the air, but would suffer no bending at the gem surface. Light entering the gem from the air along a path X'-X would likewise continue in a straight line, but would be reduced in velocity.

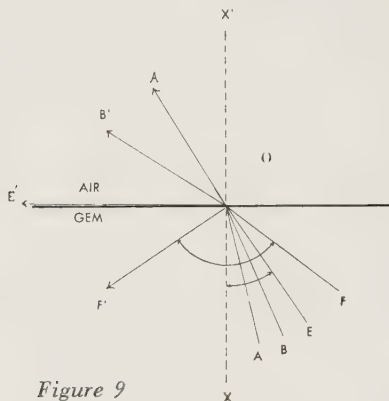

Figure 9
Refraction and total reflection.

A light beam originating at a point A in Figure 9 would travel the path designated A-A'. Light from point B, which travels along BO within the gem, would take a direction of OB' when it passed into air. As the angle to XO increased for light beams that leave the gem at point O, the farther would the light be bent from OX'. The maximum possible deflection from OX' would be reached when the light was bent at an angle to 90° as it entered the air. Such a condition is illustrated by path OOE' (Figure 9). Angle EOX is called the *critical angle* for

Refractive Index Determination

the gem, since any light which impinges on the surface of the gem at point O, at an angle greater than EOX, would be totally reflected within the gem. Beam FOF' illustrates total reflection. The size of the critical angle is dependent upon the *refractive index* of the material.

Refractive Index is defined as the ratio of the sine of the angle of incidence to the sine of the angle of refraction. It may also be defined as the ratio of the velocity of light in air to its velocity in a given substance. The higher the refractive index of the gem, the smaller its critical angle. Since the size of the critical angle is inversely proportional to the refractive index of any given substance, a measure of the critical angle will determine the refractive index. Gem refractometers are designed to measure critical angles and to translate the reading directly into a refractive index figure.

The Refractometer. *Of the many tests available to the jeweler who attempts to identify an unknown gemstone, the simplest to perform, and perhaps the most valuable in determination, is the measurement of the gem's refractive index on a refractometer.* The gem refractometer is an instrument which employs a very high-refractive-index glass hemisphere and measures the critical angle between the glass and the gem to be tested. The

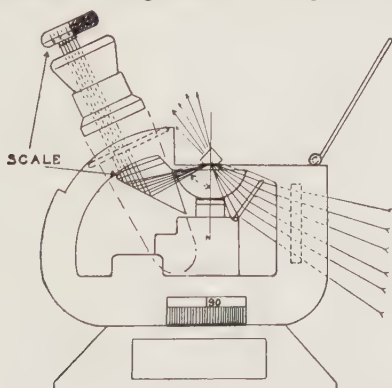

Figure 10

The optical system of the Erb and Gray Refractometer.

first gem refractometer was developed in Europe about 1885, and, until 1946, the only instruments of this nature were made in Europe.

The more recent models have a scale which automatically translates the critical angle reading into the refractive index. Light enters the back of the instrument, comes up through the glass hemisphere, strikes the gem, which is in optical contact with the top of the hemisphere, and is reflected through the lens system of the instrument to the eye. (See Figure 10). All light which enters at an angle greater than the critical angle between the glass and the substance being measured is totally reflected from that substance and comes through the scale to the eye. The light which strikes the surface of the unknown gem at less than the critical angle is lost by refraction into the gem. Thus a shadow will be seen on the scale of the instrument up to the point of the critical angle, beyond which the scale will appear bright. (See Figure 17).

The reading on the scale is easily distinguishable in white light because a narrow spectrum is visible at the dividing line between the shadowed and the bright portions of the scale, since there is a slightly different critical angle for each of the components of white light. If *monochromatic* light representing a very narrow spectral emission is used, no such spectrum appears; but instead, a very sharp division between the shadowed and the bright portions of the scale is visible.

Types of Refractometers. The **Rayner**, made in England for a number of years, is the least expensive of the several gem refractometers available to the American jeweler. It employs a fixed, dense glass prism in place of a hemisphere. The instrument is practical, efficient, especially compact, and easily transported. Two important features of the latest model are: (1) a very large light portal at the back of the instrument, and (2) a cover that fits down tightly over the gem so that no confusing extraneous light strikes the stone. The Rayner Refractometer is available in the United States for approximately \$90. B. W. Anderson and C. J. Payne, of the Precious Stone Labora-

Refractive Index Determination

tory of the London Chamber of Commerce, have designed two modifications of the Rayner Refractometer. One utilizes synthetic spinel and the other diamond in place of the dense glass prism. The advantage of the spinel lies in its low dispersion, which permits sharper readings for those gems which are lower in index than synthetic spinel. By using a liquid that has a refractive index of 2.05, zircon, all garnet species, and sphene,



Figure 11
The Rayner Refractometer.

exhibit refractive index readings on the instrument with a diamond prism.

The G. F. Herbert Smith Refractometer (first manufactured in England in 1905) is much smaller than others now on the market; nevertheless, it is very practical and efficient. It employs a segment of a hemisphere for the dense glass on which the gem to be tested rests. The American price of the Smith Refractometer is slightly in excess of \$100.

The Tully, largest of the gem refractometers, employs a revolving hemisphere to facilitate the determination of birefringence and optic character. (See following Chapter). The hemisphere has a very broad top surface on which the gem to be tested

rests. Despite the large hemisphere, it is difficult to obtain readings from very large stones with a Tully since the metal surface, parallel to the top of the hemisphere, extends above it. If the gem is larger than the top of the hemisphere, the height of the metal prevents the gem from coming into contact with the glass. The Tully is priced at approximately \$175 in America.



Figure 12

The Tully Refractometer with a Monochromatic Unit for light source.

The Erb and Gray is the most recent gem refractometer, and the first of American design and manufacture. Like the Tully, it has a revolving hemisphere. A stand, adjustable to the height of the light source, is included with the instrument, while another feature is an adjustable eyepiece for scanning the scale. The Erb and Gray has proved to be an exceptionally efficient refractometer. It may be purchased for approximately \$140.

Refractive Index Determination

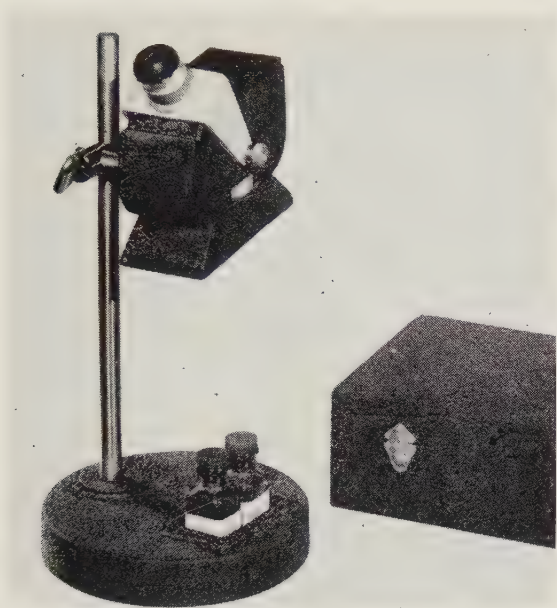

Figure 13

The Erb and Gray Refractometer on its stand, which is adjustable.

How to Use the Refractometer. The refractometer, the most useful instrument available for gem testing, is also the most delicate. Since the glass hemisphere or prism on which the gem is placed must have a refractive index well above that of the gem, it is necessary to use a glass that has a very high lead oxide content. The large percentage of lead oxide results in a glass not only very soft, but also easily corroded. The gems to be tested invariably will be much harder than the glass. Use every precaution to avoid scratching the glass by placing the gem on the instrument with care.

To produce an optical contact between the gem and the glass, a liquid of higher refractive index than that of the gem must be used. The liquid used on the refractometer is a saturated solution of sulphur in methylene iodide, with tetraiodaethylene added.

Pure methylene iodide has an index of about 1.74. The addition of sulphur to the saturation point increases the refractive index to about 1.79, and the addition of tetraiodaethylene brings the index to 1.81.

Such a liquid is highly corrosive, and must not be left in contact with the glass any longer than it takes to make the refractive index reading—if it remains on the hemisphere, it oxidizes the glass, leaving a tarnish film that seriously reduces the efficiency of the instrument. The liquid must be removed from the hemisphere immediately after the reading is made. Since most tissues have harsh fibers that will scratch the glass surface in time, special lens tissue should be used to remove the high refractive index contact liquid. Observance of these precautions will materially prolong the life of the hemisphere surface.



Figure 14

Carefully placing a gem on a drop of refractometer liquid on the hemisphere of an Erb and Gray refractometer.

Light source—Monochromatic Unit.

To determine the refractive index of a gem with a refractometer, first place a small drop of high index liquid of about 1/16 inch diameter on the refractometer hemisphere. Touch the glass rod, attached to the stopper of the liquid vial, against the mouth of the vial to remove excess liquid before transferring the drop to the hemisphere surface. Bring the rod only close

Refractive Index Determination

enough to the hemisphere for the liquid to be transferred—*not so close that the rod touches the hemisphere.*

Carefully place the gem on the drop of liquid with the largest flat facet in contact with the surface of the hemisphere. Turn the



Figure 15

Careful transfer of high R. I. liquid to Rayner prism, without touching the glass with the rod.



Figure 16

Refractive index determination on a Rayner refractometer with a substage lamp as a light source.

light shield of the refractometer down to cover the hemisphere, but never far enough to touch the gem.

Next, move a light source into position so that light enters the portal at the back of the instrument. A small microscope sub-stage lamp with a blue ground-glass filter is excellent for this purpose, although almost any diffused light source is satisfactory. Many experienced jewelers simply direct the refractometer toward the nearest window, or toward an artificial light. Adjust the light or move the instrument so that the scale is well lighted and clearly visible.

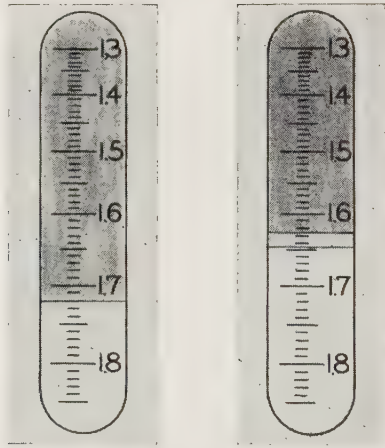

Figure 17

*Left, refractive index reading for a singly refractive gem (spinel).
Right, typical readings for the strongly doubly refractive tourmaline.*

If no clear reading is seen when the gem is first placed on the refractometer, move the stone slightly on the hemisphere. Be certain that there is no crystallized sulphur on the facet in contact with the glass. Change the position of the light to avoid missing a faint reading, and move your eye back and forth in relation to the eyepiece of the instrument. If the gem has too high an index to give a reading, the shadow should continue down the scale to the liquid reading at 1.81. If the shadow does not extend that far, but no clear reading is observed, remove the gem from the

Refractive Index Determination

hemisphere to clean both the glass surface and the gem. If the gem has other large facets, try to read the refractive index from a second facet. Occasionally, a sulphur crystal, or dust, will prevent optical contact between the gem and the glass hemisphere.

If a reading is obtained, the scale will be relatively dark from its low number end to the reading, which will appear as a narrow spectrum dividing the dark and brightly lighted portions of the scale. If the gem is strongly doubly refractive, two such spectra may appear between the dark and brightly lighted portions of the scale. The refractive index or indices may be read directly from the scale.

If the gem has an index above that of the contact liquid (1.81), no reading will be visible, but the shadow will be unbroken up to the refractive index of the liquid, which is shown by a single line at 1.81 on the scale. No gem with an index that is higher than 1.81 will give a reading on the refractometer, but the shadow should extend to 1.81, the liquid index. In addition, no reading will be observed on cabochon-cut gems, on very poorly polished gems, or on those without facets large enough to give a reading. A good refractometer should give a reading for a gem that has a flat facet one millimeter in diameter. Refractive indices can be obtained in some cases from translucent and even from nearly opaque stones. However, the lines observed are usually so blurred that only approximate values can be secured.

Readings in White Light. If the light source used to obtain the refractive index reading is daylight, or an ordinary electric light source, the narrow spectrum representing the reading will appear predominantly blue and green, with a very narrow yellow band. The reading will correspond most closely to refractive index tables if it is read at the division between the yellow and green lines, since such tables usually give the index of the material for sodium light.

Readings in Monochromatic Sodium Light. The sharpest and most accurate readings on a refractometer are obtained with the aid of a monochromatic sodium light source. The yellow

sodium light colors the scale with the same hue. Again the reading appears at the division between the shadowed and brightly lighted portions of the scale, but with the sodium lamp the separation is very sharp. Since the sodium light is monochro-

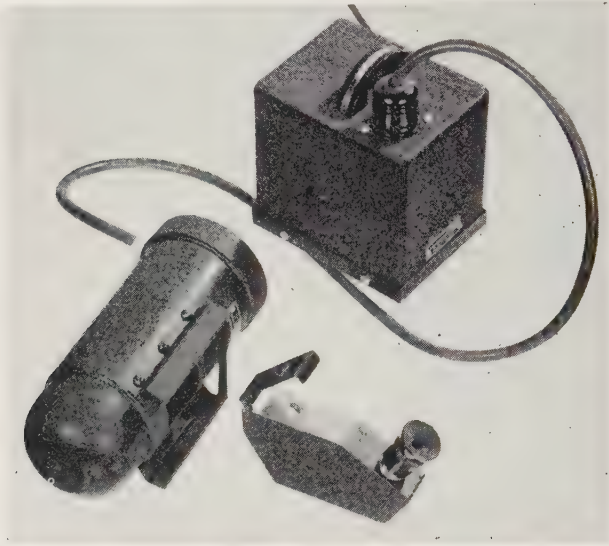

Figure 18

The G.I.A. Monochromatic Unit (with a Rayner Refractometer).

matic, no spectrum interferes with a clear reading. A very sharp shadow zone demarcation is visible that may be read to $\pm .001$. If the gem is doubly refractive, it is possible to read two indices on most facets.

Monochromatic sodium light can be provided by the G.I.A. Monochromatic Unit (See Figure 18). Salt placed in a candle or gas flame also produces a yellow light that is fairly satisfactory for refractometer determinations.

Cleaning the Refractometer. When the refractive index reading has been made, wipe the hemisphere surface clean with lens tissue. Apply a cleaning fluid, such as xylene, with lens tissue to prevent corrosion of the glass by the high index liquid.

Refractive Index Determination

If the refractometer is not to be used again for a day or two, coat the surface with a thin layer of Vaseline as a further protection.

Other Means of Determining Refractive Index. Of the several other means of determining refractive index, none of which is as satisfactory as determination by the refractometer, the simplest is the approximate immersion method.

Determination of Approximate Refractive Index by Immersion. When a gem is placed in a liquid, the degree to which it is visible in the liquid depends upon the proximity of its refractive index to that of the liquid. (See Page 67 for list of immersion liquids.) As the indices of the gem and the liquid approach the same value, the outline of the gem becomes less distinct. If the gem is almost invisible, its index very closely approximates the index of the liquid. Thus, a hessonite garnet becomes almost invisible in methylene iodide, since the index of this garnet is about 1.74—the refractive index of the liquid. Topaz and tourmaline nearly disappear when placed in cinnamon oil, which has an index of about 1.62. This immersion method is useful for the determination of approximate index, but fails to provide the exact readings obtained on the refractometer.

Determination of Refractive Index with a Microscope. There are several methods of index determination possible with a microscope. By utilizing the calibrated fine adjustment of a good microscope, it is possible to determine the actual depth of the stone and then read the apparent depth by focusing through the stone.

To determine refractive index with a microscope: Place the stone on a slide on the microscope stage with the culet down. Focus the microscope on the table, which is nearest to the microscope objective in this position, and take a reading. Turn the focusing screw down (usually only the fine adjustment is calibrated thus, the focusing must be done with this adjustment) until the instrument focuses on the culet of the gem, looking through the table; take a second reading. With the microscope focused on the glass slide on which the gem rests, take a third

reading. The difference between the first and the last reading gives the true depth of the stone while the difference between the first two readings gives the apparent depth. These two figures are sufficient to determine the refractive index, since the refractive index is equal to the true depth divided by the apparent depth.

Microscopes that have no calibrated focusing adjustments can be adapted by attaching a Vernier millimeter scale along the side of the instrument. The millimeter scale should be placed on the fixed microscope stand, with the Vernier portion on the movable side. This method of refractive index determination is not accurate, but is useful with cabochon cuts on which no refractive reading can be taken, or with gems that have a refractive index too high to be read on the refractometer.

Determination of Refractive Index by Immersion in Index Liquids. An important mineralogical test for refractive index which may be adapted for gem identification is one which utilizes liquid of known refractive index. Mineralogical laboratories are normally equipped with complete sets of refractive index liquids that are usually made in steps of .01 from 1.50 to 1.80, including some liquids that exceed 1.80 in index. Though these are valuable for testing gems that seem to have an index above the upper limit of the refractometer, or those too small or without a flat facet for a refractometer reading, the jeweler's occasion for using so many liquids is so infrequent that purchase of such a wide range is seldom worthwhile. If a large number of gems are tested, however, the infallibility of this test makes the set of liquids indispensable.

Immerse the gem in a small transparent vial of the liquid of known index of refraction. Mount the vial on the stage of a polarizing microscope. Use a small piece of opaque material to cover one-half of the opening below the polarizer at the base of the stage (between the reflecting mirror and the polarizer), with the condenser lens at its lowest position. Use an objective of medium magnification. When the gem is examined under these conditions, one of its edges will appear brighter than the other. If

Refractive Index Determination

the gem has an index of refraction higher than the liquid, the bright side will be toward the shadow caused by the partial masking. If the gem is lower in refractive index than the liquid, the brightly lighted side will be away from the shadowed side of the field.

REFRACTIVE INDEX TABLE

Gems Listed With Two Indices Are Doubly Refractive
Important gemstones are listed in capital letters.

Rutile	2.616	2.903
Anatase	2.49	2.55
DIAMOND		2.417
Sphalerite		2.37
Cassiterite	2.00	2.09
ZIRCON (alpha, beta)	1.925	1.984
Sphene	1.900	2.034
ANDRADITE		
GARNET		1.885
ZIRCON (gamma)	1.810	1.815
Spessartite garnet		1.80
ALMANDITE		
GARNET		1.79
CORUNDUM	1.762(— .003, + .007)	1.770(— .003, + .008)
Rhodolite garnet		1.76
Benitoite	1.757	1.804
PYROPE GARNET		1.746
CHRYSOBERYL	1.746(± .004)	1.755(± .005)
GROSSULARITE		
GARNET		1.745(± .005)
Azurite	1.73	1.84
Epidote	1.729	1.768
SPINEL		1.726(± .014)
Idocrase	1.713	1.718
Kyanite	1.712	1.728
Hypersthene	1.703	1.716
Zoisite	1.700	1.706
Willemite	1.69	1.72
Axinite	1.678	1.688
Diopside	1.675	1.701
Kornerupine	1.665	1.677
Malachite	1.66	1.91
JADEITE	1.66	1.68
PERIDOT	1.659	1.697
Sillimanite	1.659	1.680
SPODUMENE	1.660(± .005)	1.676(± .005)
Diopase	1.655	1.708
Enstatite	1.655	1.665
Phenacite	1.654	1.670
Euclase	1.651	1.670

HANDBOOK OF GEM IDENTIFICATION

Apatite	1.642	1.646
Andalusite	1.634	1.643
Danburite	1.630	1.636
TOURMALINE	1.624 ($\pm .005$)	1.644 ($\pm .006$)
Smithsonite	1.621	1.849
TOPAZ	1.619 ($\pm .012$)	1.627 ($\pm .012$)
Prehnite	1.615	1.646
TURQUOISE	1.61	1.65
Lazulite	1.61	1.64
NEPHRITE	1.606	1.632
Coral	1.60	1.60
Brazilianite	1.598	1.617
BERYL	1.577 ($\pm .016$)	1.583 ($\pm .017$)
Variscite	1.56	1.59
LABRADORITE		
FELDSPAR	1.559	1.566
Beryllonite	1.552	1.562
QUARTZ	1.544 ($\pm .00$)	1.553 ($\pm .00$)
Iolite	1.542	1.551
AMBER	1.54	
OLIGOCLASE		
FELDSPAR	1.539	1.547
Nephelite	1.537	1.542
CHALCEDONY		
QUARTZ	1.535	1.539
Aragonite	1.530	1.685
MICROCLINE		
FELDSPAR	1.522	1.530
Thomsonite	1.520	1.542
ORTHOCLASE		
FELDSPAR	1.518	1.526
Cancrinite	1.50	1.52
LAZURITE (Lapis Lazuli)	1.50	
Obsidian	1.50	
Serpentine	1.49	1.57
Calcite	1.486	1.658
Sodalite	1.480	
Moldavite	1.48	
Chrysocolla	1.46	1.57
OPAL	1.45	
Fluorite	1.434	

Chapter VI

Double Refraction, Pleochroism and Optic Character

The Nature of Light. The exact nature of light is not fully understood. It is apparently emitted in infinitesimal particles called quanta, and is transmitted as an electromagnetic wave. The wave motion of light may be likened in a crude way to the waves set up along a rope anchored at one end when it is snapped by sharp movements of the hand. The curve shown in Figure 19

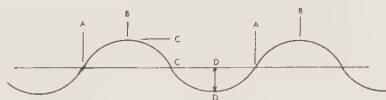

Figure 19

The wave motion of light.

illustrates the motion of light. The distance from A to A¹ or B to B¹ represents one wave length. The amplitude of the wave is the distance from C to C¹ or from D to D¹. The wave length of light is measured in Angstrom Units (one ten-millionth of a millimeter), or in millimicrons (one millionth of a millimeter).

When light is moving through air or any other gas, its waves may undulate or vibrate in any direction perpendicular to the direction of transmission. All liquids and some solids reduce the velocity of light from its velocity in air without offering restrictions other than partial absorption. Such liquids and solids are said to be *isotropic*, since the velocity of light is the same in all directions of transmission. All *amorphous* solids, such as opal and glass, and all materials which crystallize in the cubic system, are isotropic or singly refractive. Isotropic materials

HANDBOOK OF GEM IDENTIFICATION

have but a single refractive index for any given wave length of light.

Solids which crystallize in the other five crystal systems have a more complicated effect upon light as it is transmitted through them. Light is forced to vibrate in two planes at right angles to each other, and the light vibrating in one of these directions is retarded in velocity more than the other; hence, such materials have two indices of refraction. As a result, a single ray of light which enters a gem crystallized in any but the cubic crystal system is broken into two rays. Each of the two rays, vibrating in a single plane, is said to be *plane polarized*. Solids which break light into two polarized beams as it is transmitted through them are said to be *anisotropic* or *doubly refractive*. The measure of the ability of a solid, such as a gem, to convert a single ray of light into two rays having unequal velocity is called *BIREFRINGENCE*. The numerical value for a gem's birefringence is obtained by subtracting the lowest refractive index from the highest given for that gem. A short table of birefringence of gemstones follows:

Apatite004	Phenacite016
BERYL006	Euclase019
CORUNDUM008	Brazilianite019
TOPAZ008	TOURMALINE020
Andalusite009	Sillimanite021
CHRYSOBERYL009	PERIDOT038
Beryllonite010	ZIRCON059
SPODUMENE015	Sphene134
Kyanite016	Calcite172

Gems which crystallize in the hexagonal and tetragonal systems, such as sapphire, zircon, quartz and tourmaline, have one direction (*optic axis*) in which they fail to polarize light. Such doubly refractive or anisotropic materials with one direction of single refraction are said to be *uniaxial*.

Materials which crystallize in the orthorhombic, monoclinic, or triclinic crystal systems have two directions in which no polarization takes place (two singly refractive directions or *optic axes*). They are said to be *biaxial*.

Double Refraction Pleochroism and Optic Character

The best illustration of the effect of double refraction is the appearance of a double image when any object is viewed through the transparent cleavage fragments of calcite (iceland spar), which has very strong birefringence (.17). Many gems show the same effect, but to a less marked degree.

Determination of Double Refraction Under Magnification. When zircon is examined through a loupe, the lines formed by the junction of facets appear as pairs of parallel lines when examined through the stone, unless it is examined

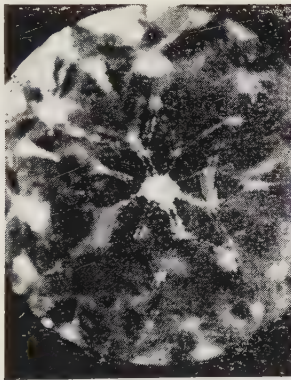

Figure 20

Doubling of back facet edges in zircon under 10X magnification.

in the one direction of single refraction. If high magnification is used, doubling of the facet edges on the side of the gem away from the objective should be seen even in gems having very low birefringence, unless the direction of observation is parallel to an optic axis. Since doubly refractive gems have directions of single refraction, absence of doubling of facet junctions should not be interpreted as evidence of single refraction, unless the stone has been observed in more than two directions. In a direction of maximum birefringence, gems with a birefringence of .004 or more should show doubling under a magnification of 30 or more diameters. Inclusions within the gem often show the same doubling under magnification. While the absence of double

images should not be interpreted as proof of single refraction, their presence is proof that the gem is doubly refractive.

The Reflection Test for Double Refraction. A simple test for double refraction in transparent faceted gems which requires no instruments is the reflection test. Cut a hole one-eighth to one-fourth inch in diameter in a piece of white cardboard or stiff white paper. Hold the card so that sunlight or light from a powerful lamp passes through the hole and falls upon the crown of the gem. Light entering the crown will be reflected from the pavilion facets and refracted from the crown back to the lower side of the card to form a pattern of small dots. The dispersion of the gem often causes a pattern of rainbow spots. If the gem is doubly refractive, the spots will appear on the card in pairs.

THE POLARISCOPE

Perhaps the simplest, yet one of the most valuable instruments used in gem identification, is the polariscope. Although polari-

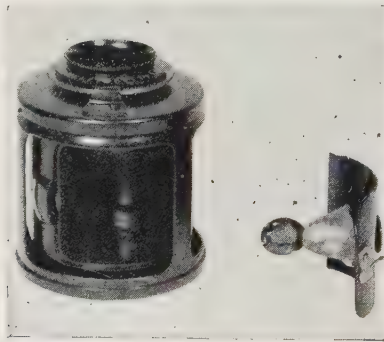

Figure 21
The Shipley Hand Polariscope.

scopes had been used for more than a century, it was not until 1935 that one designed especially for gem testing, by Robert Shipley, Jr., was placed on the market. Since the instrument is both efficient and inexpensive, it has become standard equipment in almost every American gem-testing laboratory. The Shipley

Double Refraction Pleochroism and Optic Character

Hand Polariscope is manufactured by the Gemological Institute of America.

Two polariscopes are now made by the Polarizing Instrument Company. One is very similar to the Shipley instrument, but the second, a more expensive instrument, is a large table model with a quartz wedge.

The polariscope consists of two Polaroid plates mounted at the ends of a cylinder that revolves between them. The fixed lower plate (polarizer) is slightly larger than the upper Polaroid

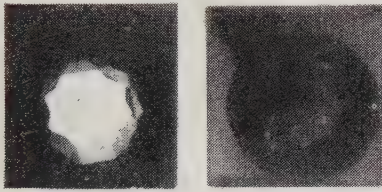

Figure 22

Behavior of a doubly refractive stone in the polariscope. At left, the gem is light; at right, a 45-degree turn of the cylinder twists the stone to its dark position.

(analyzer), which can be rotated. The gem to be examined is attached by means of beeswax to a knurled knob on the door which fits into the revolving cylinder. The gem may be turned about two mutually perpendicular axes, without dismounting.

To Test for Double Refraction in the Polariscope: Mount the stone on the small door which fits into the side of the instrument. Turn the polariscope toward a fairly strong light source, such as a microscope substage lamp. Turn the upper Polaroid to the position in which a minimum of light is allowed to come through the instrument. Rotate the cylinder between the Polaroid plates while observing the gem. If the stone becomes alternately light and dark at 90° intervals, double refraction is indicated. If it remains dark in all positions, single refraction is indicated.

Caution: Since doubly refractive gems have one or two directions of single refraction, it is necessary to examine them in more than two directions before assuming the gem to be singly refractive.

During one complete revolution, doubly refractive gems become brightly lighted four times and dark (extinguished) four times. Singly refractive gems remain dark by comparison and show no pronounced change from light to dark as the cylinder is rotated.

The jeweler must watch for singly refractive materials which show a condition (caused by strain within the gem) called anomalous double refraction, which may be confused with true double refraction.

The Polariscopes Test for Anomalous Double Refraction. Place the gem on the wax mount on the door. Turn the upper Polaroid plate to the position in which a minimum light transmission through the instrument is permitted. Place the door in position, and rotate the cylinder. If the intensity of the light

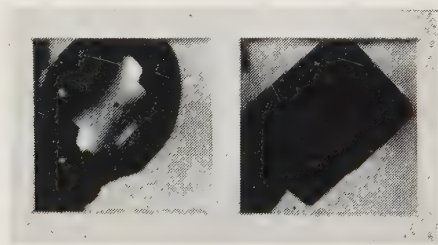

Figure 23

Left. Anomalous double refraction as seen in some glass imitations. Right. A singly refractive stone, which remains dark in all positions in the polariscope.

passing through the stone changes, turn the cylinder until the stone is in its brightest position. To determine whether the intensity change is caused by true or anomalous double refraction, turn the upper Polaroid until the polariscope allows maximum

Double Refraction Pleochroism and Optic Character

light transmission while holding the cylinder in a fixed position.

If the light coming through the stone either remains constant or decreases during the process, the stone is truly doubly refractive.

If the light coming through the stone increases as the upper Polaroid is rotated, anomalous double refraction is indicated.

Doubly Refractive Crystalline Aggregates. Doubly refractive material such as jade, which is composed of numerous tiny crystals, causes a distinctive effect in the polariscope. When the two Polaroids are in the crossed, or dark, position, such gems will appear uniformly bright as the cylinder is rotated. Chalcedony and jade always react in this manner in the polariscope. The failure to extinguish in any position is a consequence of the random orientation of the multitude of tiny crystals which comprise the aggregate. In all positions of the cylinder a sufficient number of the small crystals are oriented in a direction in which light may pass, so that the gem will never darken. Some corundum also fails to extinguish in the polariscope. As a result of repeated twinning, certain sets of thin plates are in the dark (extinction) position while the alternate parallel plates are not; hence the gem appears light in all positions.

PLEOCHROISM

Light which is transmitted through doubly refractive gems vibrates in two planes at right angles, with the two beams suffering unequal reduction in velocity. Traveling separate paths at different velocities, the two beams often suffer unequal absorption in colored anisotropic gemstones and emerge as different colors. This property is called **PLEOCHROISM**. Pleochroic gems in the hexagonal and tetragonal crystal systems show two different colors and are said to be *dichroic*.

DICHOISM is described as *strong, distinct, or weak*. Ruby, for example, shows very strong dichroism; emerald, distinct dichroism; citrine quartz, weak dichroism.

Pleochroic gems which crystallize in the orthorhombic, mono-

clinic, and triclinic systems may show three colors when viewed in various directions, but more often only two are easily distinguishable. Those in which three colors can be distinguished are said to be *trichroic*. TRICHOISM is described in the same manner as dichroism. Ruby, sapphire, emerald, and zircon are dichroic; the alexandrite variety of chrysoberyl is trichroic.

Pleochroism often can be seen without instruments, if the gem is examined from different directions. To see more than one color in any single direction, it is necessary to use optical instruments.

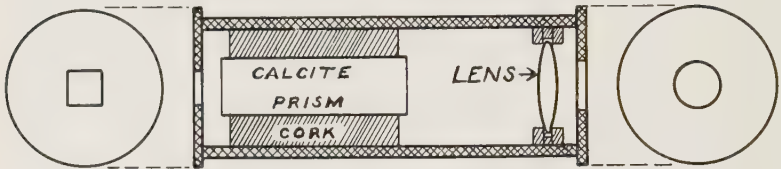

Figure 24

Dichroscope construction.

The Dichroscope. The dichroscope is a small instrument that employs the strong double refraction of colorless calcite to separate the two polarized rays of a dichroic gem. It consists of a tube with a square or rectangular aperture at one end, a cleavage piece of calcite with polished ends in the center, and a low power lens at the eyepiece. Dichroscopes are among the least expensive of gem-testing instruments. They are manufactured in this country and in England, and are available at the Gemological Institute of America, Los Angeles, for less than fifteen dollars.

Light, on entering the calcite, is broken into two polarized rays which have vibration directions at right angles to each other. These two rays are slowed unequally by the calcite so that one is bent (refracted) considerably more than the other. Two images of the square or rectangular aperture are visible through the dichroscope. The two images will have different colors when a pleochroic gem is examined through the instrument.

Double Refraction Pleochroism and Optic Character

To Test a Gemstone for Pleochroism with the Dichroscope. For best results, hold the instrument toward a white light source. Reflection of light from a white wall gives excellent



Figure 25

The G.I.A. Dichroscope.

results. Be careful to avoid the use of daylight reflected from some strongly colored object. Artificial light is satisfactory, but must be fairly intense. A microscope substage lamp with a blue filter or fluorescent light is also effective.

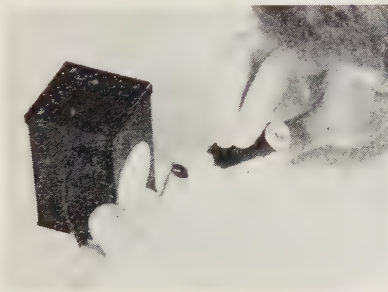

Figure 26

Preparing to examine a gem with a dichroscope before a substage lamp. For best results, the gem should be 1/2-inch from the instrument.

Hold the gem in a pair of tweezers close to the aperture of the dichroscope so that the stone is in focus. The stone should be examined in more than two directions in order to be certain

that the first two directions did not happen to be parallel to optic axes, along which even a strongly pleochroic gem would show no pleochroism.

A gem which shows trichroism would display, for example, red and green in one direction, green and yellow in a second, and red and yellow in a third direction. Only two of the three trichroic colors could be seen in any one direction. Since pleochroic colors of a gem are often distinctive, the determination of pleochroism is valuable in gem identification. While many gems are doubly refractive, the number which show strong dichroism is small. Tables indicating the characteristic dichroic colors of various gems are included in each of the identification chapters.

The direction in which dichroism can be seen is also important because it gives an indication of the synthetic or genuine origin of corundum. Almost all genuine corundum is cut so that the table is at right angles to the optic axis, while most synthetic gems are cut so that the table of the cut stone is usually more or less parallel to the optic axis. As a result, natural ruby and sapphire seldom show dichroism when viewed through the table, whereas their synthetic counterparts show strong dichroism through the table.

Use of the Polariscopes in Detecting Pleochroism. The polariscopes detect pleochroism effectively when the polarizers are turned to the parallel position, allowing maximum transmission of light. When mounted within the cylinder between the polarizer and analyzer, a pleochroic stone will show different colors in positions 90 degrees apart, as the cylinder is rotated. The polariscopes are a less satisfactory instrument for the determination of pleochroism than is the dichroscope, because the two colors are not seen simultaneously as they are in the latter. Nevertheless, there are gemologists who feel that the polariscopes offers a more effective means for detecting pleochroism in very light stones in which no color difference can be detected with a dichroscope.

OPTIC CHARACTER

The determination of the uniaxial or biaxial character of a

Double Refraction Pleochroism and Optic Character

doubly refractive gemstone often provides an important clue to its identity.

Uniaxial gems have two refractive indices, one of which is constant for any direction. The other index varies from the constant index to a point above or below it. If the constant index is the lower, the material is said to be positive. If the upper index is constant, and the lower is variable, the stone is said to be negative.

Optically *biaxial* gemstones are also either positive or negative, but since they have three refractive indices (only the highest and lowest are given in most refractive index tables), the signs are determined in a different manner. The highest and lowest indices vary from their maximum and minimum positions to the intermediate (beta) index. If the highest index (gamma) is closer to the intermediate one than is the lowest index (alpha), the gem is said to be negative. If the lowest is closer to the intermediate one, the gem is said to be positive. Optic character might seem to be out of place in a text of this nature, but the determination is not difficult with the refractometer and may be accomplished partially with the polariscope, so it is a practical aid in identification.

Determination of Optic Character on the Refractometer. If the refractometer has a revolving hemisphere and a monochromatic light source is used, it is often possible to determine the optical character of a gemstone. If, as the hemisphere is rotated, one refractive index reading remains the same while the other varies, the gemstone is uniaxial. If the lower index is the one that does not vary, the gem is uniaxial with a positive optic sign. If the higher index is constant but the lower index varies, the optical sign is negative. The birefringence of the gem is represented by the maximum difference between the two indices.

Biaxial gems are distinguished on the refractometer by a variation of both the upper and lower indices as the hemisphere is rotated. The same effect is noted on a refractometer with a fixed dense glass hemisphere or prism by rotating the gem instead of

the hemisphere. As the biaxial gem is rotated, both the high and low indices vary; the high from an intermediate point up to a maximum reading, and the low from a minimum reading up to the same intermediate position. The optical sign of the biaxial gem may be determined by noting whether the minimum or maximum reading is farthest from the intermediate position from which both vary. If the numerically higher reading is closer to the intermediate index than is the lower, the gem is said to be optically negative. If the lower index is closer to the intermediate index, the gem is said to be optically positive. Isotropic gems give a single sharp reading on any facet large enough to give a reading.

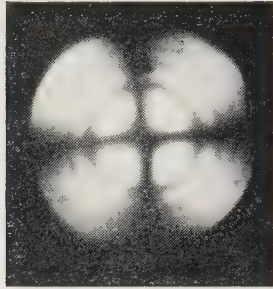

Figure 27
A uniaxial interference figure.

The Use of the Polariscope in the Determination of Optic Character. There are several tests that may be performed with instruments used primarily for other purposes that will materially assist in an occasional difficult identification. One of the most valuable is the determination of optic character with the polariscope.

If a doubly refractive gem is examined through the polariscope in a direction parallel to an optic axis, an interference figure will be seen under certain conditions. Figures 27 and 28 illustrate uniaxial and biaxial figures observed in this way. Three conditions must be observed to obtain an interference figure in the

Double Refraction Pleochroism and Optic Character

polariscope: (1) the gem must be mounted so that an optic axis is perpendicular to the Polaroid plate (parallel to the length of the cylinder); (2) the analyzer (upper Polaroid plate) must be turned to the extinction (dark) position; (3) a condensing lens effect must be obtained.

The second condition is easily met, but the first and third are more difficult. Since the majority of uniaxial gems are cut with the table more or less perpendicular to the optic axis, mount the

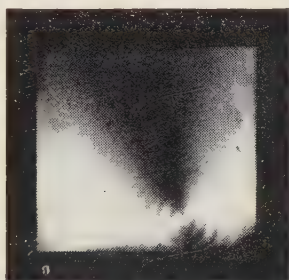

Figure 28

A biaxial interference figure parallel to an optic axis.

stone so that the girdle is attached to the wax and the table is parallel to the analyzer. The observer is able to recognize the correct orientation by the appearance of bright colors within the gem. If the optic axis is parallel to the cylinder of the polariscope, there should be a minimum light intensity change as the cylinder is rotated. If the first position in which the gem is mounted does not seem to be parallel to the optic axis, turn the knurled knob on the door on which the gem is mounted, while observing the gem. As the cylinder is rotated, a dark line may be observed. Turn the knob on the door in the direction which causes the dark line to become more sharply defined. As the line appears sharper and narrower, interference colors should appear.

The third condition may be difficult to meet in a faceted gem, but gems cut *en cabochon* act as condensing lenses. Therefore, interference figures are usually resolved in such gems in determ-

ining the singly or doubly refractive character. Two principal methods of producing the condensing lens effect are available with faceted gems. A simple method involves the placing of a drop of viscous liquid on the gem after it has been oriented properly. A small plano-convex lens mounted in the wax above the gem, after the correct orientation has been made, will magnify the interference figure.

The distinction between uniaxial and biaxial gems has many uses. It is the easiest way to distinguish between precious moonstone (orthoclase) and the chalcedonic quartz variety, since both are normally cut *en cabochon* and no condensing lens is necessary to resolve the interference figure in precious moonstone. Since chalcedony is composed of a multitude of tiny crystals, no figure can be obtained. Similar determinations also serve to distinguish between topaz and tourmaline, and between corundum and chrysoberyl. The addition of a quartz wedge to the tester's equipment materially increases the value of interference figures, since the optic sign (positive or negative) can be determined with the wedge.

The beginner will find difficulty in obtaining interference figures with the polariscope, except when gems are cut *en cabochon*. However, the test becomes so valuable in difficult identifications that it is wise to develop the necessary technique.



Figure 29

Chapter VII

Magnification

Importance to Gem Identification. The most vital single factor in the correct identification of gems is the proper use of magnification, since clear resolution of inclusions is essential to distinguish man-made substitutes from natural gemstones. Almost every jeweler has become proficient in the use of the eye loupe to seek out imperfections in diamond. The care that is used to grade diamonds, however, is seldom carried over into the examination of colored gems, even though the imperfections or inclusions may mean a greater value differentiation than is true in the case of diamond. The difference lies not in a reduction of value because of the presence of flaws, but in the proof of artificial or natural origin established by flaws. Many jewelers will base an identification on a hasty examination of a gem that may be genuine ruby or synthetic ruby with a difference in value of \$5,000 to \$100,000. The same jewelers will spend ten minutes or more grading a diamond for flawlessness, although the flawless stone may be worth only \$50 more than the slightly imperfect stone. Obviously, then, the examination of colored gems demands the careful attention of the jeweler. There are several means of magnification the gem tester can utilize in his laboratory.

MAGNIFYING INSTRUMENTS

Numerous types of loupes and microscopes are used for gem identification. The magnification range is from two to over six hundred diameters. Under the loupe and under the microscope,

efficient lighting of the gem is essential to successful magnification. Inasmuch as a transparent gemstone is usually cut for maximum brilliancy, the reflection of light from its many facets adds materially to the examiner's difficulties. The lighting prob-



Figure 30

Diagram of a dark-field illuminator

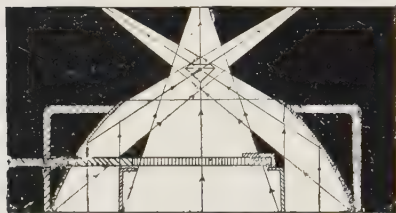

Figure 31

Diagram of a direct illuminator.

lem increases with increasing magnification; in fact, magnifications of 200 diameters or more are rarely useful in gem identification. It is apparent that the magnifier chosen by the gem tester must be one which has an efficient light source or one that may be so adapted that efficient lighting is easily obtained. Dark-field illumination, in which light is directed into the gem from the side, usually provides the most efficient method of illuminating the interior of a gemstone. (See Figure 30).

Loupes. Lenses of many diameters and various magnifications are used in jewelers' loupes. The best of these are triplets, corrected for chromatic and spherical aberration. The correction, both practical and necessary, places the entire field in focus at

Magnification

once and eliminates the confusing color fringe visible around magnified objects seen through an uncorrected loupe. (See Chapter X on distinction between synthetic and genuine gems.) The wider the field of the ten power corrected loupe, the more light it transmits to the eye, increasing its usefulness. If a loupe of ten power or higher magnification is not corrected, the field, partially masked, is small.

A loupe of less than ten power will seldom resolve inclusions well enough for the observer to determine their nature. A loupe



Figure 32
The G. I. A. 10X Eye Loupe.

of greater than ten power has so short a focal distance that adequate lighting is achieved with difficulty and observation becomes more complicated.

Only in a minority of examinations will skilled use of the best of loupes provide satisfactory magnification for distinction between genuine and artificial or synthetic gemstones. For the majority of identifications, the higher magnification provided by the microscope is essential.

Microscopes. Microscopes are manufactured for a wide variety of specialized scientific and industrial purposes. Many types may be adapted for fairly efficient magnification of gems. Medical and biological stands, both monocular and binocular, prove very useful in gem tests. The binocular microscope has several advantages over the monocular. It has a wide field of vision, permitting a much greater area to be covered at a given

magnification than is possible with any other type of microscope; the stereoscopic vision afforded by the binocular system permits inclusions to be located definitely within the stone by coordination of the observer's eyes; and it does not reverse the object as does the monocular instrument. There are four instruments that have been especially adapted in the United States for gem examination by the addition of stone holders, special illuminators, and other equipment to improve gem resolution.



Figure 33
The Diamondscope.

The Diamondscope. The Diamondscope employs a binocular microscope mounted on a base containing a built-in illuminator designed for gemstone examination. This instrument has adjustable paired 15X wide-field eyepieces which are used in conjunction with paired 0.7X, 2X, and 4X objectives. The latter, set in a revolving nosepiece, may be thrown alternately into line with the eyepieces by a turn of the wrist to give magnifications of 10.5X, 30X, and 60X. Magnifications as low as 7X and

Magnification

as high as 150X may be obtained with additional eyepieces and objectives. The Diamondscope's objectives are designed to be approximately parfocal; i.e., the instrument remains nearly in focus when the objective is changed.

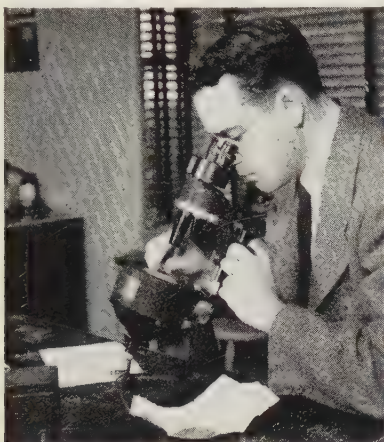

Figure 34

Examining a gemstone under 60X on the Diamondscope.

A mechanical stone holder (Figure 36) which may be mounted on either side of the illuminator base, is furnished to hold either mounted or loose gems. The illuminator base has an interchangeable background for dark-field and direct illumination of a gem.

With its many features designed for the most efficient examination of gems, the Diamondscope is perhaps the most practical gem microscope. However, the name Diamondscope is a trademark name controlled by the American Gem Society, which does not sell, but only leases the instrument subject to rulings governing its use in business.

The Diamond Imperfection Detector. The Diamond Imperfection Detector, a magnifier mounted on the same type of illuminator base as that of the Diamondscope, employs a monocular, rather than a binocular microscope. There have been several models of the instrument with an average magnification range from 10X to 150X. Changes of magnification on most

models are accomplished by turning the objectives in a multiple nosepiece. This instrument also utilizes a mechanical stone holder designed for gemstones. Monocular microscopes are much less expensive than the complicated binocular instruments, but they lack the effective stereoscopic vision of the paired optical system.

The Gemolite. A second monocular microscope adapted for gem identification, the Gemolite, has a base with a built-in light source designed for the most effective illumination of gem-



Figure 35
The Gemolite.

stones. The stone to be examined is held in a mechanical stone holder that will grasp both mounted and unmounted gems. Imperfections within a gem under observation on a Gemolite appear as light objects against a black background. The most complete Gemolite model (pictured in Figure 35) has a range of magnification from 10X to 100X with several intermediate powers.

Magnification

The Gemological Microscope. In the gemological microscope, which is a polarizing microscope adapted for gem examination, a special condenser and polarizer allow more light to reach the stage than does the conventional polarizing microscope.

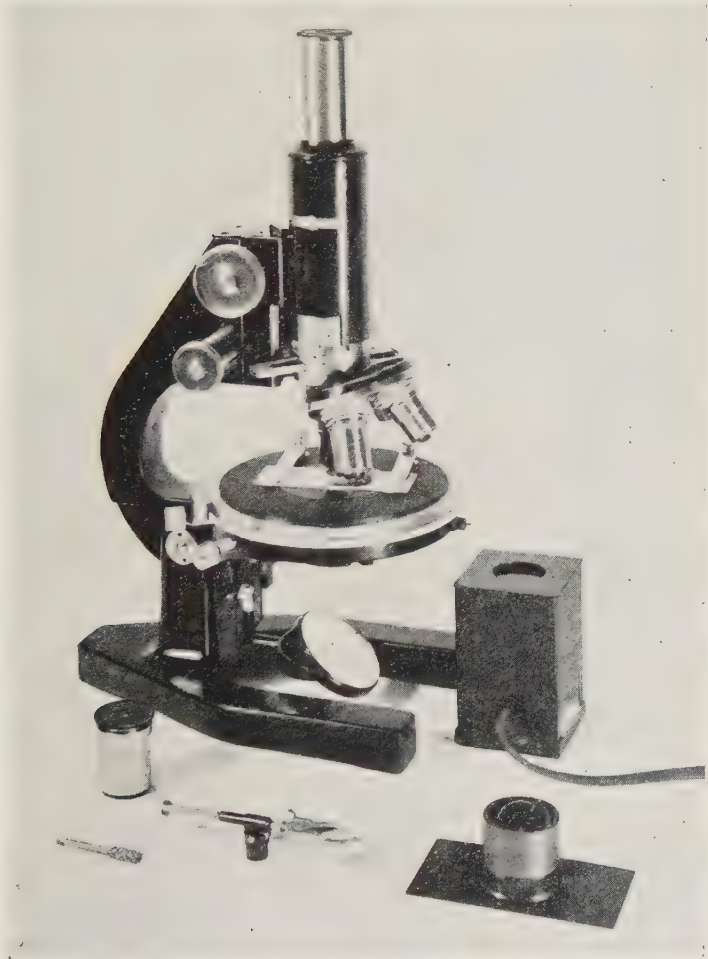

Figure 36

The Gemological Microscope (Bausch & Lomb) with accessories.

Like the Gemolite and the Diamond Imperfection Detector, it employs a monocular optical system, but it lacks the illuminator base of those instruments. With the polarizing microscope, the usual form of illumination is a substage lamp placed just ahead of the mirror below the stage. A wide Polaroid plate replaces the lower Nicol prism of the conventional polarizing microscope and a larger condensing lens is used. The gemological microscope (Figure 36) retains the usual features of the polarizing microscope, but adds a mechanical stone holder which is mounted on the revolving stage. This instrument normally provides a magnification range from five to four hundred diameters.

PROCEDURE FOR THE EXAMINATION OF GEMS UNDER MAGNIFICATION

Since examination procedures vary according to the types of magnification described in the preceding paragraphs, the use of each instrument will be described separately. A certain portion of the procedure for gem examination under magnification is necessary whatever the type of magnification employed.

Cleaning the Gemstone. All stones must be carefully cleaned before they are examined. The most confusing aspect of the classification of gemstones inclusions under magnification is the presence of surface dust which may easily be mistaken for internal inclusions. The possibility for costly interpretative errors emphasizes the need for exceptional care in cleaning a gem. Many cleaning methods may be used effectively, but some are more efficient than others. Probably the best cleaning method is that in which the gem is dipped into carbon tetrachloride, acetone, alcohol, or some similar solvent, and then wiped carefully in a piece of red silk. Silk is preferable to cotton or other cloth, since it is less likely to leave lint on the stone. While any color would suffice, a brightly colored silk cloth is best since its threads will not be readily confused with internal imperfections. In the absence of a solvent, careful rubbing with a silk cloth may render the gem sufficiently clean to avoid confusion. The care-

Magnification

fully cleaned stone should be mounted without being touched by the fingers. A small camel's hair brush is a helpful accessory to flick off any surface dust that remains after the stone has been mounted. The major difficulty encountered by the novice in microscopic examination of gemstones (the confusion of surface dust with internal imperfections) will be rendered negligible if the gem has been carefully cleaned.

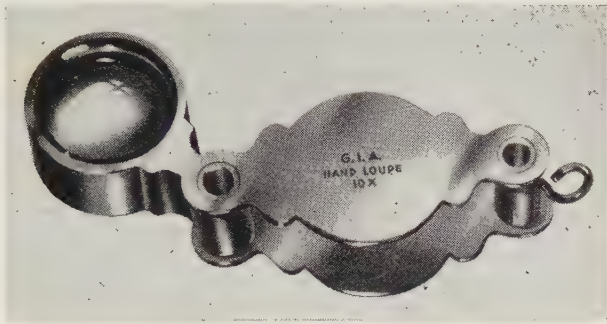

Figure 37

The G.I.A. 10X Hand Loupe.

The Use of the Loupe. The brilliant-cut gemstone must be as carefully lighted for loupe examination as for examination under higher magnification. Carefully clean the stone to remove dust, pick it up with stone tweezers, and hold over a black background. With a small lamp, direct light into the gem from the side. Imperfections within the gem will appear as bright objects clearly visible against a black background. The dark-field illumination described improves visibility of inclusions under all the many types of jewelers' loupes.

The Use of Microscopes. Mounting the Stone in a Mechanical Holder. If the gemstone is to be examined under the Gemolite, Diamond Imperfection Detector, Diamondscope, or the gemological microscope, remove it from the silk cloth with the mechanical stone holder without touching it with the fingers. For best results, place the gem, table down, on the silk and grasp it at the girdle. Mount the stone holder on its

post on the instrument, and turn it so that the stone can be examined with the table facing the microscope objective.

Mounting the Stone on a Glass Slide. If a microscope without a mechanical stone holder is used, the gem is usually mounted on a glass slide. A small piece of beeswax, plasticine or other material that can be shaped easily, is used to hold the stone. To mount the stone, hold it in tweezers to avoid touching it with the fingers and apply wax to the girdle. By means of the wax, transfer the stone to a small glass microscope slide and place the slide on the stage of the microscope. For best results, mount the stone with the table parallel to the slide and with the culet resting on the slide. The gem may be placed table down on a glass slide without using wax if the microscope is in a vertical position, but it is more difficult to see inclusions clearly from this direction, whereas mounting with wax takes little time and places the stone in a position especially advantageous for examining the interior.

Focusing. First make certain that the microscope has its lowest power objective in position, then use the coarse adjustment knob to turn the body tube down so that the objective comes close to the stone.

Caution: To avoid damage to either objective or gem caused by lowering the objective until it strikes the stone, adjust the body tube downward, while observing the objective from the side of the instrument, until it nearly touches the stone.

The light used with either an ordinary or a polarizing microscope should be approximately adjusted to a position which permits a maximum illumination of the gem before a focus is attempted.

Bring the gem into focus by raising the body tube with the coarse adjustment knob while looking through the instrument. When the gem has been resolved under low power, adjust the light more carefully for maximum illumination of the stone's interior. If the microscope does not have an illuminator base, im-

Magnification

prove resolution of the gem's interior by holding a small sub-stage lamp beside the stage of the instrument.

As the gem comes into focus, the culet will appear first; then, as the tube is raised farther, the table will appear. If the focus is changed *very slowly* from culet to table, any inclusions within the gem will come into and out of focus as the tube is raised to a focus on the table. When this focus change is made on a polarizing microscope, use the fine adjustment knob.

Distinction Between Dust and Inclusions. Surface dust, easily mistaken for internal imperfections in a gem, constitutes a confusing element for the beginner in gemstone identification. Even an experienced microscopist occasionally encounters difficulty because of dust. Since the most careful cleaning will seldom remove all surface dust, the observer must become adept at distinguishing correctly between dust and inclusions.

If the objects in question are exactly in focus when the table is in focus, it will not be difficult to determine that they are on the surface. If there is any doubt, touch the table of the gem with a camel's hair brush to see if the supposed imperfections disappear.

Dust on pavilion facets is especially confusing. When the focus is raised from the culet to the table, pavilion facets come into focus from the bottom to the top; thus, surface dust and true inclusions come into resolution at the same time. If the stone is mounted, and therefore difficult to dust with a camel's hair brush, it is often possible to remove dust from pavilion facets by blowing sharply against the gem.

To best determine whether an object apparently resting on a pavilion facet is surface dust or an internal imperfection, observe the facet junctions very carefully. Where the facets meet along the back of the gem, only the portions in the plane of focus will be seen clearly. If the object in question is between adjoining facet junctions, it is probably on the surface. If the object in the center of the stone, or at some distance from any surface which is in focus when the inclusion is most clearly visible, it must be within the stone. A mechanical stone holder is helpful in this

determination because in it the gem may be easily turned for better perspective and its pavilion facets may be more readily cleaned with the camel's hair brush.

Higher Magnification. Examination of the gem under lowest magnification will usually disclose internal imperfections in most colored gems, whether synthetic or genuine. Often, however, although imperfections are discovered, higher magnification is necessary to catalogue them correctly. With higher magnifications it is essential to increase the light sufficiently to bring the inclusions into clear resolution. When magnification is over one hundred diameters, a very brilliant light is essential to light the interior of the stone sufficiently to see inclusions clearly. Sharpness of definition decreases with increase in magnification. This, together with the lack of sufficient light, places a very definite upper limit on the use of higher magnification.

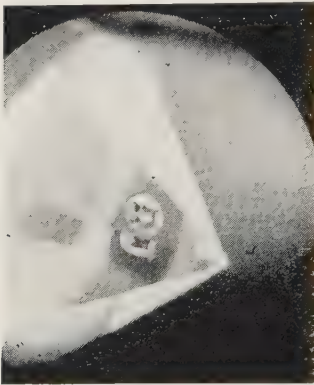

Figure 38

Pavilion view of a single included crystal.

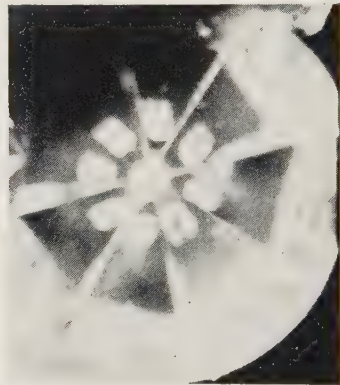

Figure 39

Table view of the same inclusion, which appears as eight inclusions by reflection.

Immersion. Lighting the interior of a gem for most efficient examination under higher magnification is complicated by the reflection from the polished facets. Gems are faceted to take full

Magnification

advantage of their ability to bend light which enters them. Since the quality of brilliance requires that the gem return to the eye as much as possible of the light that enters the top of the stone, normal lighting of the microscope stage is insufficient for an examination under higher magnification.

The confusing effect due to reflections from the facets may be avoided by immersing the gem in a liquid whose refractive power is close to that of the gem. If a gem is suspended in a liquid that has a refractive index equal to its own, it becomes practically invisible; the facets are no longer a cause of distortion, and lighting becomes a much simpler problem. It is not necessary for the liquid to be close in index to the gem under examination. Any liquid, such as water or mineral oil, is helpful, but with gems of high refractive index a liquid with an index higher than that of water will give best results.

The following are suggested as suitable immersion liquids:

Liquid	Refractive Index
Water	1.34
Olive Oil.....	1.47
Glycerine	1.47
Benzol	1.50
Clove Oil	1.53
Anise Oil	1.56
Bromoform	1.59
Cinnamon Oil	1.62
Methylene Iodide.....	1.74

The Immersion Cell. The method of using an immersion liquid will vary depending upon the equipment. Immersion cells, essential accessory equipment for the microscope or loupe, increase the value of these instruments, since they become more efficient magnifiers when the gemstone is immersed.

The use of an immersion cell has many advantages: (1) the observer experiences much less difficulty in seeing into a highly reflective gem; (2) light penetrates the gem, thoroughly illuminat-

ing inclusions; (3) the distinction between surface and internal imperfections is facilitated; and (4) growth lines become much more evident.

An immersion cell developed for gem testing is the Shipley Universal Motion Immersion Stage pictured in Figure 40. Although the stage was designed for the gemological microscope, it may be used effectively with almost any microscope. The advantage of this cell is apparent from its name. The two knurled knobs at the side of the cup turn two rings within the liquid. The gem is mounted on a wax-covered, metal nubbin which fits over a post on the inner ring. By turning the two knurled knobs and the stage of the microscope, the gem may be examined from any direction. The universal motion greatly facilitates the determination of optic character on the gemological microscope.

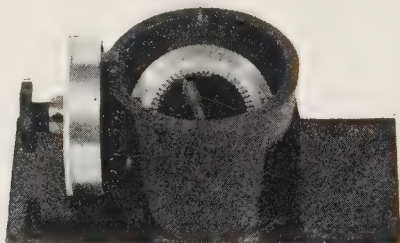

Figure 40

The Shipley Universal Motion Immersion Stage.

If the jeweler has no manufactured immersion cell, an excellent one may be improvised by using a small glass beaker, or even a very small drinking glass, with a fairly clear bottom and sides which allow light to enter the liquid. The gem to be examined may be placed in the bottom of the immersion cell, held in the liquid by means of tweezers, or held in wax attached to a rod of any type. For convenient manipulation of the stone, if held in tweezers or on the end of a rod, the sides of the immersion cell must be low; preferably about an inch high.

Another type of immersion cell is easily made by cutting off the bottom of a glass test tube of fairly small diameter. Little liquid is required to fill the small hemisphere that remains, and

Magnification

the gem can be supported on the bottom of the curve without the aid of a stone holder. A cylindrical section of a test tube cemented to a glass slide also makes an effective immersion cell.

Determinations Facilitated by Immersion. Assembled Stones. Immersion is an excellent means for quick and positive identification of assembled stones. In DOUBLETS OR TRIPLETS the separation planes are easily seen either as planes of bubbles or as divisions between two distinct colors. In GARNET-AND-GLASS DOUBLETS, the genuine inclusions in the garnet cap are seen, as well as the bubbles that appear where the glass back has been fused to the garnet. In addition, the difference in luster and transparency of the garnet and the glass are readily seen.

Natural or Synthetic Origin. To find corundum and synthetic corundum to be almost entirely without visible flaw is not uncommon. If it is not possible to determine the natural or man-made origin of a ruby or sapphire by observation in air, immersion is the only alternative. Since it is possible to examine the interior of an immersed stone with increased efficiency, the examiner often finds hitherto unseen imperfections that provide the necessary evidence for a decision as to the synthetic or natural character of spinel or corundum. If however, no inclusions are resolved, he must seek out growth lines.

Immersion in a liquid such as bromoform and a careful control of the light source provide effective conditions for growth line resolution. Light must be reduced to a pin-point source either by an iris diaphragm below the immersion cell, or by an opaque cover with a small opening over the light source. The light source should be directly below the stone in line with the microscope. With practice curved striae in synthetic corundum and the straight zoning of natural ruby and sapphire can be resolved almost without exception.

Double Refraction and Birefringence. Even weak birefringence or double refraction is evidenced by the appearance of a doubling of the back facets of an immersed gem. The junction line between two facets will appear to be doubled and will

show as two parallel lines where only one actually exists. Gems of high birefringence such as zircon (.059), peridot (.038), benitoite (.047), and tourmaline (.020) show this phenomenon-

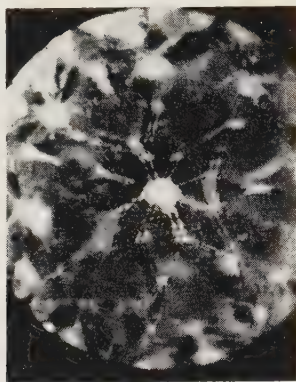

Figure 41

Doubling of back facet edges in zircon under 10X magnification.

even in tiny stones. If large gems (two or more carats) are examined, even materials with weak birefringence, such as topaz (.008) and beryl (.006) will show doubling of the back facets.

The same doubling of images applies to inclusions. Small inclusions in corundum and synthetic corundum often show this effect, rendering it difficult to distinguish the shape of the objects.

Doubling of back facets and inclusions is, of course, proof of double refraction. By the amount of doubling, the examiner can roughly estimate the birefringence of the gem. By examining a zircon, a peridot, a tourmaline and a sapphire of about the same depth, the microscopist can get an idea of relative birefringence that will enable him to judge an unknown fairly accurately.

Chapter VIII

The Use of Characteristic Imperfections as a Means of Gem Identification

The tests commonly used in gemstone identification are based upon definite, tangible instrument determinations: the refractometer and specific gravity tests give definite numerical results, the dichroscope may show distinct colors, and polariscope determinations are clear-cut. Employing prescribed instruments and established methods, a jeweler, after sufficient practice, can become skillful in securing satisfactory results with these instruments and methods.

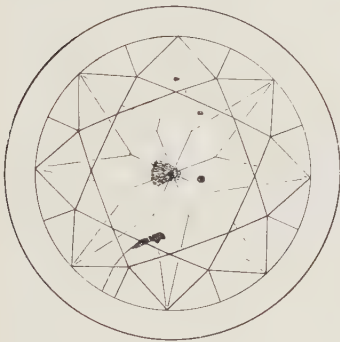

Figure 42

The appearance of a gem under magnification in ordinary illumination.



Figure 43

The same gem lighted by a dark-field illuminator such as that of the Gemolite.

By comparison, proficiency in identification of gemstones by means of their characteristic inclusions or imperfections involves a knowledge not quickly obtained by reading the printed page. To acquire skill in this method of identification, the jeweler must

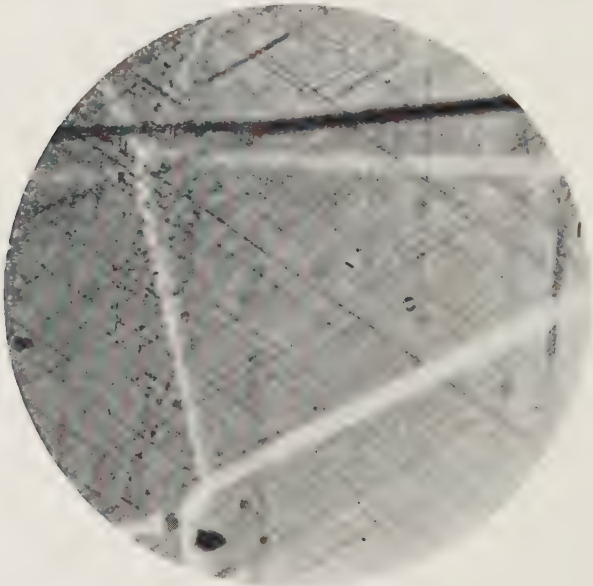

Figure 44

“Silk” consisting of three sets of rutile needles arranged at 60 degrees to each other in natural corundum.

be thoroughly familiar with the subject of magnification; he must have a keen eye for accurate classification of inclusions or imperfections which involve, at times, the most fanciful shapes. Much more experience in the observation of gemstones will be required to achieve skill in this method.

Each time a jeweler makes a positive identification by the standard methods, he should examine the gem under high magnification in order to build up a working knowledge of the internal characteristics of gemstones.

Gem Identification by Characteristic Imperfections

Lighting. Ordinarily a jeweler examines a gemstone with the light directed from behind the stone, with the result that inclusions appear as dark objects against a light background.

DARK-FIELD ILLUMINATION, in which the light is directed upon the stone from the side, is by far the best method of lighting for an examination of inclusions, since it not only enables the observer to locate imperfections more readily, but also aids identification of included crystals by revealing them as light objects against a dark background.

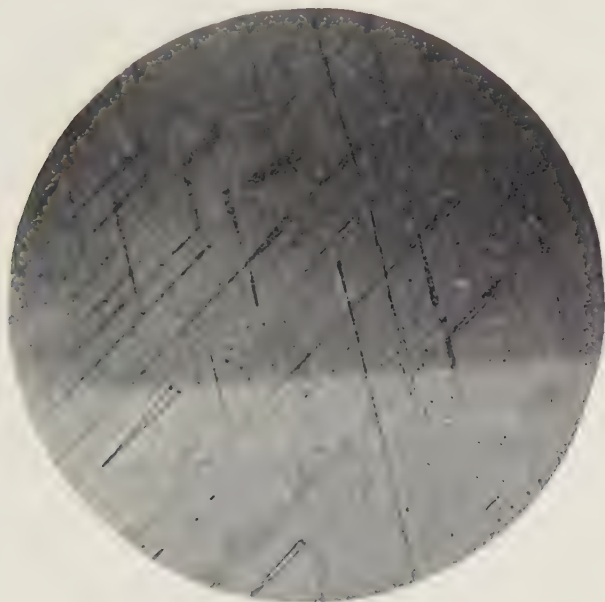

Photo by E. Gubelin

Figure 45

"Silk" formed by negative crystals in natural corundum.

Imperfections. Included under the term *imperfections* are surface and internal fractures and cleavages, gas and liquid inclusions, and crystal and other solid materials enclosed within the gem. In some gemstones the inclusions are sufficiently characteristic to permit an immediate identification of the stone.

Fracture. Four gems may be identified with some degree of certainty on a basis of their fractures.

Chalcedony has the conchoidal fracture common to most gems, but the luster on the fractured surfaces is dull or waxy, not glass-like as in other gems.

Hematite fractures are characteristically splintery, resembling a break in wood.

Turquoise is often identified by its dull to waxy luster on small fracture surfaces in contrast to the vitreous luster of its glass imitation.

Zircon derives a characteristic appearance from its strong tendency to "pit" or crumble at facet edges. Heat treated zircons are especially subject to such pitting.

Most other gems display a conchoidal or "shell-like" fracture, with a vitreous luster on the fracture surface.

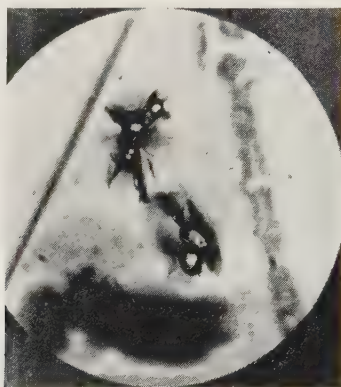

Figure 46

Included zircon crystals surrounded by a "halo" of black fractures in natural corundum.

Cleavage. Since few gems of importance are likely to show cleavage, straight cracks in a gem are important as clues to its identity, while the angles between cleavage cracks may assist the jeweler to determine the system in which the gem crystallizes.

CHRYSOBERYL, DIAMOND, the FELDSPAR GEMS, SPODUMENE (which often shows cleavage cracks in one and not uncom-

Gem Identification by Characteristic Imperfections

monly, in a second direction) and TOPAZ are the gemstones in which cleavage is likely to be observed.



Photo by E. Gubelin

Figure 47

Spinel octahedra as inclusions in natural sapphire with strong color zoning.

Important Genuine Gemstones and their Characteristic Inclusions.

Corundum. Study the photomicrographs of corundum (Figures 44 to 52) carefully. Usually the experienced gemologist can identify the corundum family under the microscope immediately by means of several types of characteristic inclusions.

The CRYSTAL INCLUSIONS encountered in ruby and sapphire have the following characteristic appearances:

“*Silk*” inclusions are of two types. One consists of *long crystals of rutile*, straight and needle-like in appearance, and arranged in three sets of parallel threads which intersect each other at sixty-degree angles. The second type of “*silk*” inclu-

sion is formed of a similar arrangement of *negative crystals* which are *long, narrow and hollow*.

Almandite garnet and quartz are the only other gems in which



Figure 48

Six-sided mica and other angular inclusions in sapphire.

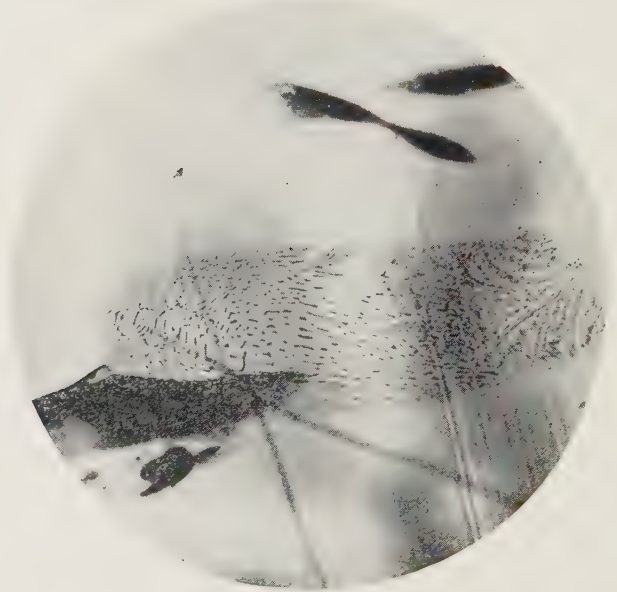

Photo by E. Gubelin

Figure 49

"Fingerprint" patterns of liquid inclusions in natural sapphire.

Gem Identification by Characteristic Imperfections

needle-like crystals appear to intersect at sixty-degree angles (see description of almandite garnet inclusions). In these gems the needles are shorter and not so well developed as in corundum.

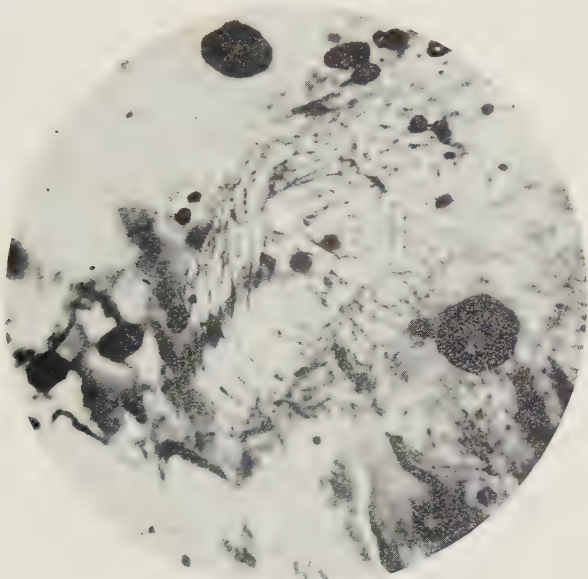

Photo by E. Gubelin

Figure 50

Solid six-sided opaque inclusions and liquid inclusions in a Siam ruby.

Included zircon crystals are characteristically surrounded by a halo of black fractures. Zircon, with its higher refractive index, stands out against the surrounding corundum as a bright point of light. The black halo of fractures around zircon crystals is thought to be caused by radioactive disintegration in the zircon.

Tiny spinel octahedra (eight-sided crystals that resemble two pyramids base to base) are found in corundum, especially in rubies from Burma and sapphires from Ceylon.

Other solid crystal inclusions which may be encountered in ruby and sapphire are:

Mica inclusions, six-sided, colorless or brown.

Hematite slabs, brown or black, (often with a hexagonal outline).

Garnet in rounded grains.

Rutile in coarse crystals.

Corundum crystals and grains with low relief.

The "FINGERPRINT" INCLUSIONS (Figure 49) take their name from interesting clouds of hollow inclusions filled with liquid and gas that form patterns resembling fingerprints around crystal inclusions. Though similar inclusion-filled planes occur in other gems, the liquid inclusions rarely have the regular pattern common in ruby and sapphire.

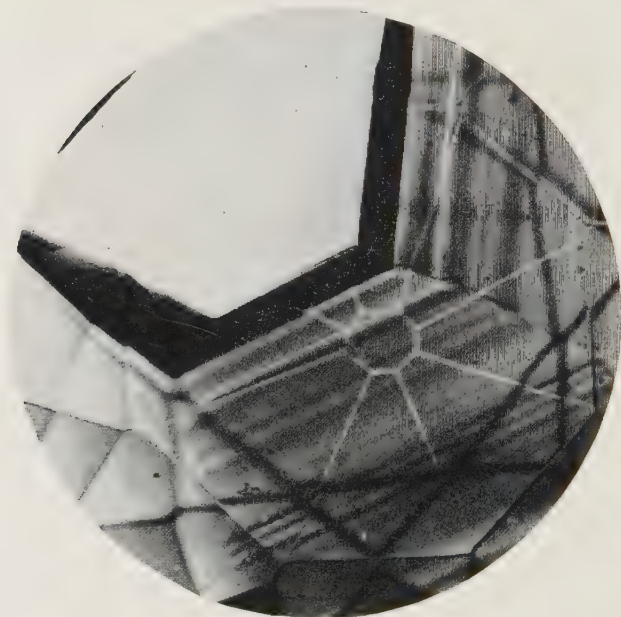

Figure 51

Strong hexagonal color zoning in natural corundum.

Siam rubies are characterized by the "fingerprint" inclusions, black solid inclusions and a lack of "silk" common to corundum from other localities.

Gem Identification by Characteristic Imperfections

VERY PROMINENT HEXAGONAL GROWTH AND COLOR ZONES are common in both ruby and sapphire (Figure 51). In Burma rubies, however, a streaked and wavy color distribution is characteristic.

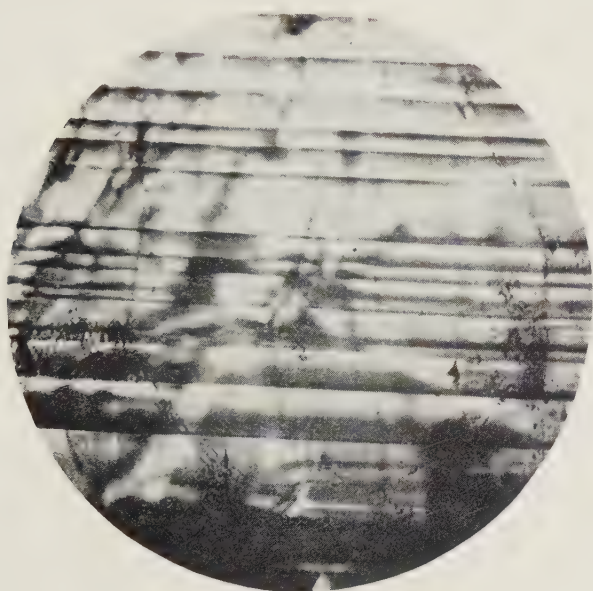

Figure 52

Photo by E. Gubelin

Straight parallel zoning caused by repeated twinning in corundum.

AN EFFECT CREATED BY REPEATED TWINNING constitutes an interesting phenomenon occasionally seen in corundum — the only colored gem likely to show it. Straight parallel lines, more widely spaced than “silk” or color-zoning striae, extend all the way across the gem. When the twinned stone is placed in the dark (crossed Nicols) position in the polariscope, or under the polarizing microscope, the gem remains light in all positions and does not exhibit the usual four light and four dark positions of a doubly refractive gem during a three hundred and sixty-degree rotation.

Tourmaline. RED TOURMALINE (rubellite) is typified by *many internal fractures* which are roughly parallel to the long axis of rubellite crystals. The fractures are usually gas-filled and give mirror-like reflections.

GREEN TOURMALINE seldom contains fractures parallel to the long axis of the crystal. It is characterized by *long, irregular, thread-like liquid and gas inclusions* evenly distributed in abundance throughout the gem. Rubellite has these same capillary-size liquid inclusions, but seldom in the abundance common in green tourmaline. The numerous tiny liquid inclusions of green tourmaline have an appearance unlike other gems.

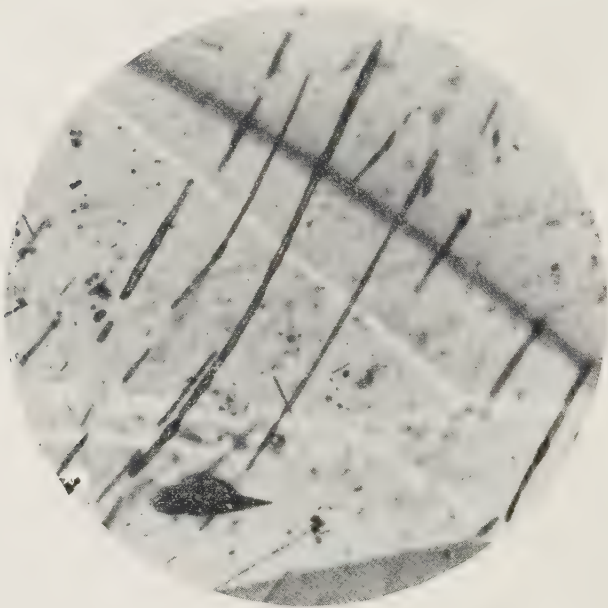

Figure 53

Photo by E. Gubelin

Coarse rutile needles and liquid inclusions in almandite garnet.

Garnet Group

Almandite. Under magnification ALMANDITE GARNET is likely to be confused with ruby, since it *sometimes contains*

Gem Identification by Characteristic Imperfections

grains of radioactive zircon as well as "silk" in a pattern that may appear similar to that found in ruby. There, however, the similarity ends.

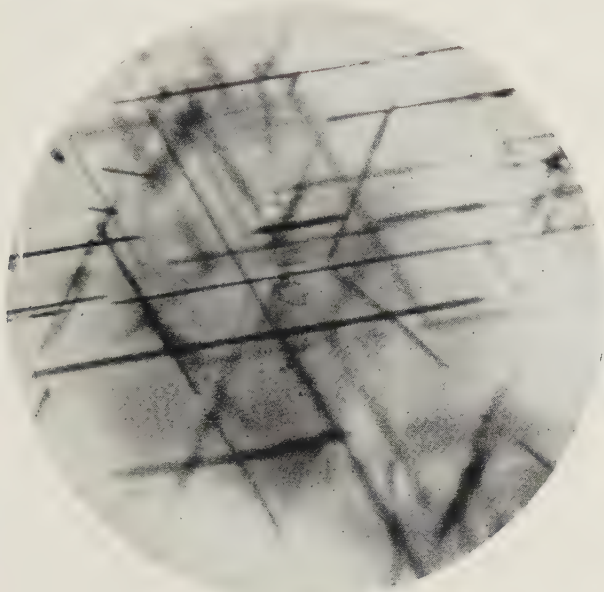

Figure 54
"Silk" in almandite garnet.

Almandite garnet is frequently observed in which one can see two sets of needle-like inclusions intersecting at angles of 70° and 110° . The angle of 70° is close to, and might be mistaken for a 60° angle on casual inspection. Since there are three such paired sets of inclusions in some almandite, there are certain directions along which a three-fold grouping of inclusions similar to that of corundum may seem to be present.

The "silk" in almandite is coarser and shorter, and usually less abundant than its counterpart in corundum. Evenly distributed small, colorless grains in great abundance that are often doubly refractive in the singly refractive garnet, together with the stubby "silk," suggest almandite.

Grossularite. GROSSULARITE GARNET usually contains *short, stubby, rounded, hollow liquid-filled prisms in quantity*. A characteristic peculiar to the HESSONITE VARIETY of grossularite is a *swirled "heat-wave-over-hot-pavement" effect* which gives the observer the impression that it is impossible to properly focus his microscope on the interior of the gem (See Figure 55).

Andradite. The *demantoid variety* of andradite garnet exhibits inclusions similar to *very fine "silk" in characteristic radiating*, rather than parallel arrangement, which identifies it at once. (Figure 56.)

Pyrope. PYROPE GARNET has an internal appearance similar to that of almandite, but often with large rounded crystal grains and liquid inclusions of very low relief.

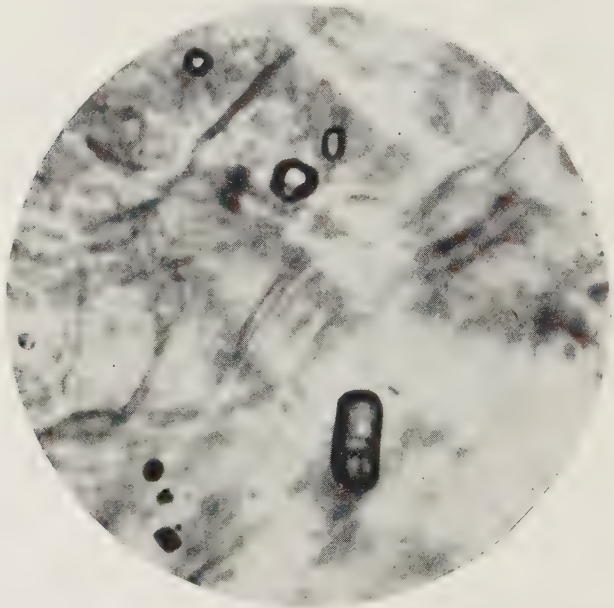

Figure 55

Photo by E. Gubelin

Stubby rounded prisms and swirled effect typical of hessonite.

Beryl

Emerald. EMERALD, one of the gemstones most easily identified by its imperfections, contains not only *many crystal inclusions*, but also *three-phase inclusions* — *irregular spaces filled with solid, liquid and gaseous matter*.

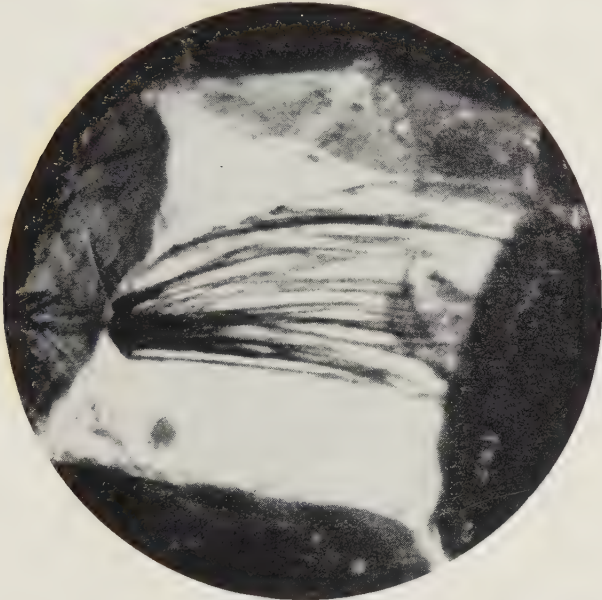

Photo by E. Gubelin

Figure 56

Characteristic "horse-tail" inclusions that identify demantoid.

An examination of its three-phase inclusions often establishes the locality in which the emerald was mined. COLUMBIAN EMERALDS contain *tiny, tabular crystals which appear square*, in spaces partially filled by liquid and gas. (Figure 57). URALIAN OR RUSSIAN EMERALDS contain *tiny, flat, diamond-shaped crystals* within gas and liquid-filled inclusions.* (Figure 58).

The characteristically shaped *brass-yellow cubic crystals of pyrite* are often seen in emerald, and because they appear black in transmitted light, are usually referred to as carbon (Figure 59).

*"Differentiation between Russian and Colombian Emerald" by Edward Gubelin, *Gems & Gemology*, Summer, 1940, pages 89-92.

A badly fractured appearance is very common in emerald under magnification.

Aquamarine. Though AQUAMARINE is often free from inclusions, it may show characteristic *brown, iron oxide inclusions* and *tiny, parallel liquid-filled spaces*.

Other Gemstones

Spinel. SPINEL'S characteristic inclusions are usually formed by tiny enclosed octahedral (eight-sided) crystals of spinel. The included crystals are found both scattered in a random distribution, and in layers of many crystals. The layers of crystals are sometimes parallel to octahedral faces of the spinel where they formed as the crystal grew, but more often these are distributed along irregular fractures.



Figure 57

Photo by E. Gubelin

Three-phase inclusions in emerald with a square crystal, indicating Colombian origin.

Gem Identification by Characteristic Imperfections

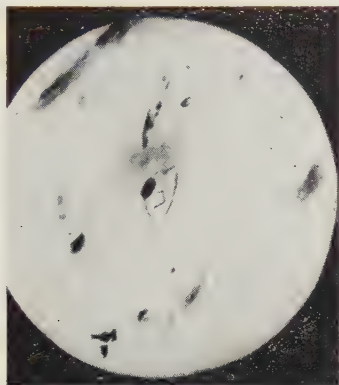

Figure 58

The diamond-shaped tabular crystal in this three-phase inclusion in an emerald indicates Russian origin.



Photo by E. Gubelin

Figure 59

Pyrite inclusions in a Colombian emerald.

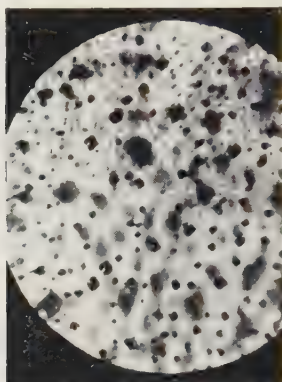

Figure 60

Numerous octahedral spinel crystals, which typify natural spinel.



Photo by E. Gubelin

Figure 61

Irregular gas-and-liquid-filled space in topaz. Two liquids which are not miscible are enclosed.

Gem Identification by Characteristic Imperfections

Topaz. TOPAZ is more likely to be free from inclusions than almost any other important gem. Its characteristic inclusions are irregular, often fairly large liquid and gas-filled spaces, which may contain two or more non-miscible liquids separated by a clear dividing line. (Figure 61.) *The easy cleavage parallel to the base of the orthorhombic topaz crystal is sometimes shown in the cut gem by straight feathers.* No other gem in the topaz color range is likely to show cleavage traces.

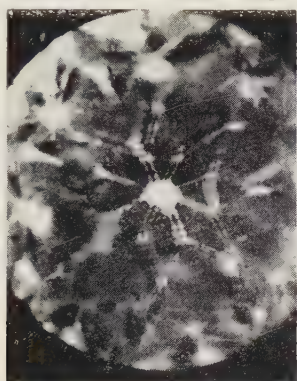

Figure 62

Doubling of back facet edges in zircon under 10X magnification.

Zircon. The several unique inclusion features of ZIRCON leave no question as to its identity under magnification.

The high birefringence of *all but green zircon* results in a *strong doubling of the back facets* in zircon of any other color. The junction of two facets appears to be two lines when the microscope is focused through the gem onto the pavilion facets. Similarly, *inclusions in all but green zircon* appear doubled.

White zircon often has many inclusions so tiny that they cannot be resolved individually, but give a total effect referred to as "*cottony.*"

Zircon, unlike diamond, *appears cloudy*, rather than clear or sharply transparent.

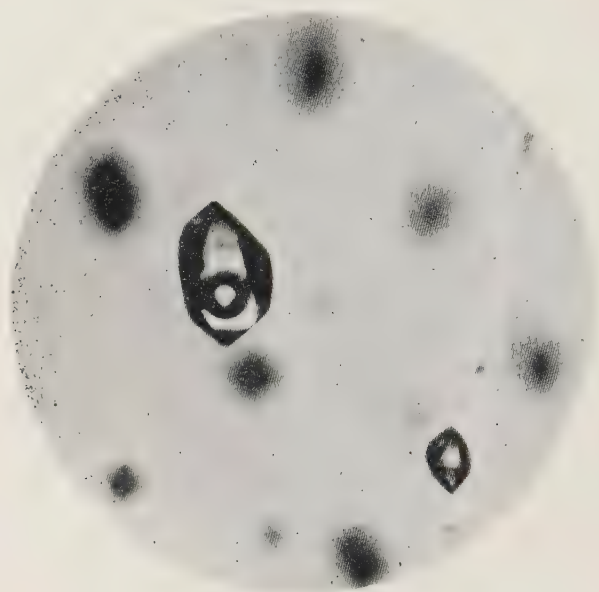

Figure 63

Liquid and a gas bubble in negative crystals in rock crystal quartz.

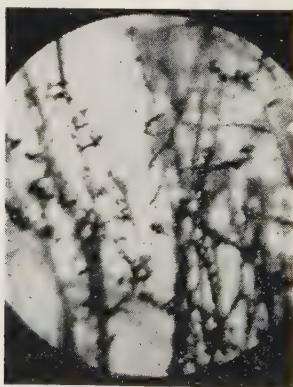

Figure 64

Moss-like arrangement of manganese oxide in moss agate quartz.

Gem Identification by Characteristic Imperfections

Occasionally zircon contains *flat planes of worm-like inclusions, roughly circular* in contrast to the angular-patterned liquid inclusions of the corundum "fingerprint."

Quartz. The species QUARTZ has more gem varieties than any other mineral. The crystalline varieties AMETHYST, CITRINE, ROCK CRYSTAL and SMOKY QUARTZ are characterized by inclusions of *negative crystals in the usual hexagonal crystal form of quartz*. However, crystalline quartz is often flawless.



Figure 65

A colorless octahedron of diamond as an inclusion in diamond (taken under dark-field illumination).

Cryptocrystalline quartz (CHALCEDONY) has no inclusion typical of all varieties. The *dendritic arrangement of manganese oxide* in MOSS AGATE is characteristic of that variety.

The INCLUSIONS THAT CAUSE A STAR IN QUARTZ are unlike those that produce asteriated ruby and sapphire. The *needle-like inclusions are very short and occur in small "bundles" distributed*

at random throughout the gem. Each of the tiny "bundles" consists of three sets of needle-like inclusions at 60° to one another. Star quartz seldom appears in the jewelry trade without a red or blue mirror backing to give color and to strengthen the star.

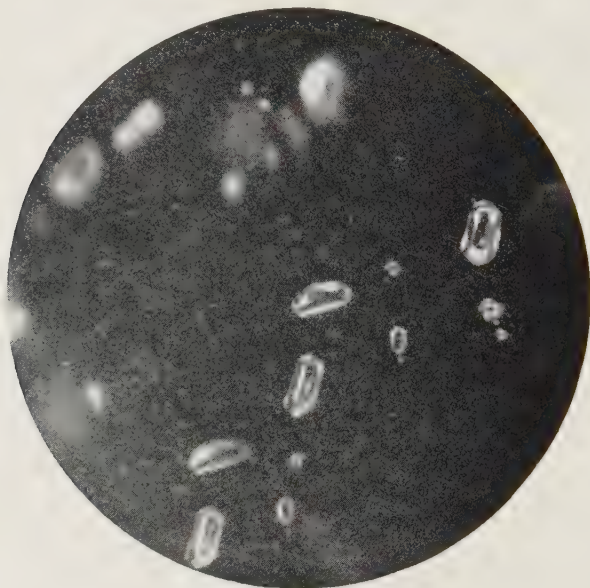

Photo by E. Gubelin

Figure 66

Zircon crystals included in diamond.

Diamond. The several inclusions which may be observed in DIAMOND, characteristic of the gem, are:

Tiny included crystals of diamond (likely to be confused with black carbon inclusions unless viewed properly; i.e., by dark-field illumination). Colorless, transparent octahedra and tetrahedra of diamond are the usual diamond inclusions.

What seem to be *included crystals of zircon* are common in diamond. They are four-sided tetragonal prisms terminated at both ends. (See Figure 66.)

SYNTHETIC GEMSTONES AND THEIR
CHARACTERISTIC INCLUSIONS

In many cases the standard tests for identification of a gemstone will preclude the necessity of an examination of its inclusions, since so few gem species are synthesized. Differentiation between genuine and synthetic stones, however, depends upon the jeweler's ability to recognize inclusions characteristic of each gem. Since synthetics are quite common on the present market, the value of a sound knowledge of the characteristic inclusions of gemstones is emphasized, for the jeweler is frequently called on to distinguish between a genuine and a synthetic stone.

The three important gems made synthetically have characteristic differences under high magnification. Although inclusions commonly found in synthetic corundum, spinel and emerald are discussed in the chapter on synthetic gemstones, they are of such



Photo by E. Cubelin

Figure 67

Elongated gas bubbles and curved striae in synthetic sapphire.

importance to the jeweler in identifying gems that it is well to describe them here as well.

Synthetic Corundum. *Spherical gas bubbles* are characteristic of SYNTHETIC CORUNDUM and may have the following appearance and arrangements:

They may be *round in cross-section, but elongated*, like a bubble which has risen from its original position in a molten material. (See Figure 67.)

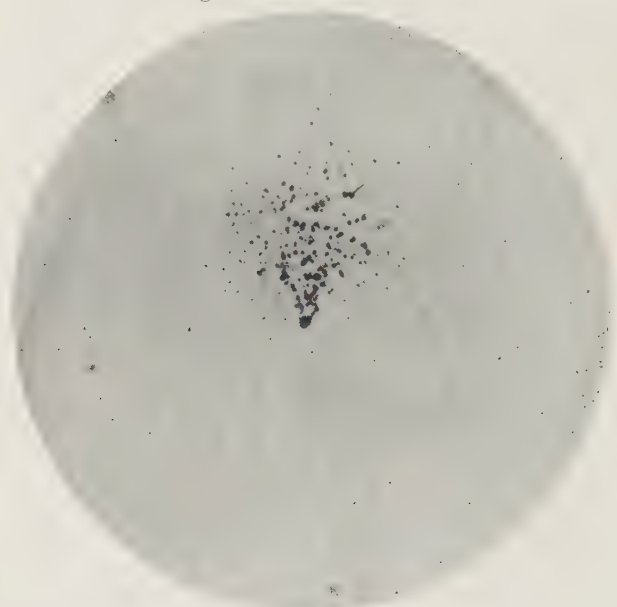

Figure 68

A patch of tiny spherical gas bubbles in synthetic corundum.

They may be found in *groups of many tiny bubbles*, frequently with one or two large bubbles in addition, or as *rough lines of bubbles arranged on a curve*. (See Figure 68.)

Curved growth lines, or striae, are usually evident in synthetic corundum, and are characteristic of that synthetic material alone. (See Figure 67.)

Gem Identification by Characteristic Imperfections

Caution: Since polishing marks on a facet may resemble striae, be sure to focus the microscope on a point within the gem when observing the stone for curved striae, and be certain that the striae continue across several facets.

Synthetic Spinel. *Spherical gas bubbles, usually very small and quite widely separated, rarely grouped, are characteristic of SYNTHETIC SPINEL.*

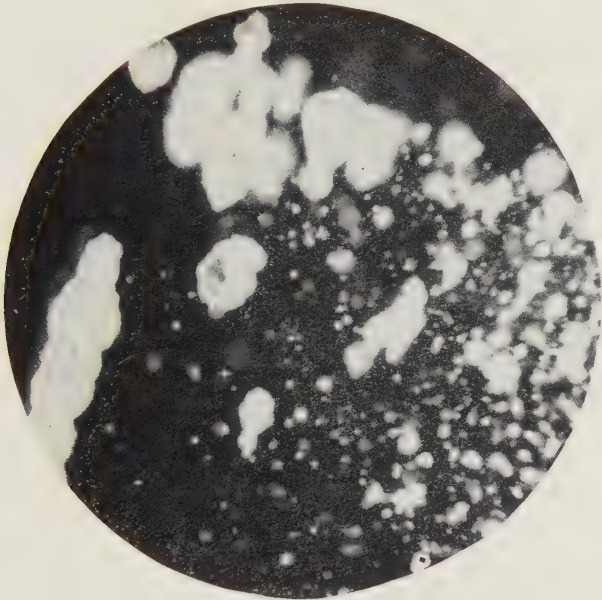

Photo by Gubelin

Figure 69

Spherical and pointed gas bubbles in synthetic spinel.

Small inclusions which have the appearance of white bread crumbs in dark-field illumination also characterize synthetic spinel. (See Figure 69.)

Synthetic Emerald. SYNTHETIC EMERALD is distinctly different from either synthetic spinel or synthetic corundum in that it contains no spherical bubbles and never has curved growth lines.

Its inclusions have a *deceptively genuine appearance*. Indeed, the new American-made synthetic emerald bears such a close resemblance to the genuine gem that it is unwise for the inexperienced jeweler to attempt to distinguish between the two by

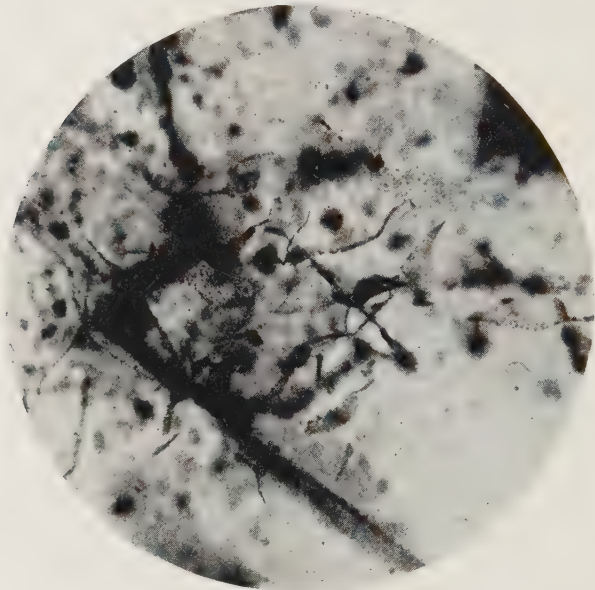

Photo by G.I.A.

Figure 70

Wisp-like patterns of liquid inclusions in synthetic emerald.

means of inclusions. Natural emerald often show three-phase inclusions (solid, liquid and gas within the same space). Columbian emeralds have tiny square crystals and Russian emeralds have diamond shaped crystals in the spaces partially filled by liquid and gas. Pyrite crystals are common in natural emerald.

Fortunately, both German-made and American-made synthetic emeralds fluoresce *strongly under ultra-violet radiation of 2500Å.*, with the emission of a red color, in contrast to genuine emerald.

Gem Identification by Characteristic Imperfections

Characteristic of AMERICAN-MADE SYNTHETIC EMERALDS are included *hexagonal emerald crystals of low relief*.

A characteristic of the EARLY GERMAN SYNTHETIC EMERALDS, less evident but still apparent in the new American-made type, is the *presence of wisp-like, or veil-like groups of liquid inclusions*.

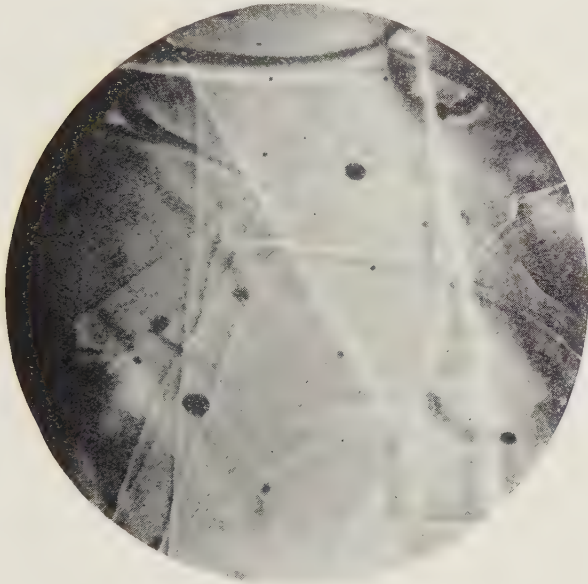

Figure 71

Swirl-marks or flow lines with spherical bubbles in glass.

Glass. *Spherical or elongated gas bubbles and swirl marks, or flow lines, characterize glass. The latter are caused by incomplete mixture of the ingredients of the melt or are formed by pressure as the glass is molded into its faceted gem appearance.*

Often *insoluble angular material* is mixed with glass to simulate the genuine inclusions of certain species of gemstones. Such inclusions are seldom an accurate representation of those of the genuine gem, but a hasty examination may lead to an incorrect identification.

Conclusions.

It is manifestly impossible to convey by word alone a sufficiently accurate description of characteristic inclusions so that the reader will be able to identify a gemstone simply on a basis of its appearance under high magnification. The purpose of this chapter is to call to the attention of the reader the possibilities of the use of a gem's imperfections as a means of identification which will become increasingly valuable to him as he becomes more adept at gem testing.

Chapter IX

Color Filters and Fluorescence

White light is composed of wave lengths representing all colors of the spectrum; the white light that we see is simply a blend of all the spectral colors in definite proportions. When light passes through a colored gem, certain wave lengths present in white light are almost completely absorbed by the gem, other wave lengths are permitted to pass through. The blending of the various wave lengths emerging from the stone produces a sensation in the eye that we call color. Thus, ruby absorbs most of the wave lengths of blue light in the spectrum while permitting most of the red and some orange and other wave lengths to pass through. The combined effect of these is the characteristic red of ruby. Transparent gems give the appearance of being colored because they subtract from white light a large percentage of the colors other than the one in which they appear.

It is not necessary to have light from all portions of the spectrum to produce white light. A mixture of colored lights having the same balance will also produce white light; i. e., a red and a green light produced by spotlights, when thrown on the same screen, appear white to the eye. Likewise, the same color effect can be produced by several different combinations of absorption. Not all red stones owe their redness to the absorption of the same wave lengths. It is for this reason that the spectroscope can be used in gem identification.

The Emerald Filter. The phenomenon of selective absorption is also utilized in color filters such as the familiar emerald filter. Emerald permits the passage of long wave lengths of red light, while absorbing light of a narrow wave band in the yel-

low-green portion of the spectrum. The emerald filter permits the yellow-green portion of the spectrum to pass through, but absorbs the remainder of the green portion. Hence, when an emerald is viewed through the emerald filter, the green fails to pass through; and the gem, therefore, takes on the color of the next most predominant wave length, deep red.

How to use the Emerald Filter. Hold the unknown gem over a strong white light source (daylight or a 100 watt frosted blue bulb are satisfactory) and examine it with the emerald filter held close to the eye. Glass imitations, synthetic corundum, synthetic spinel, peridot and tourmaline appear green through the

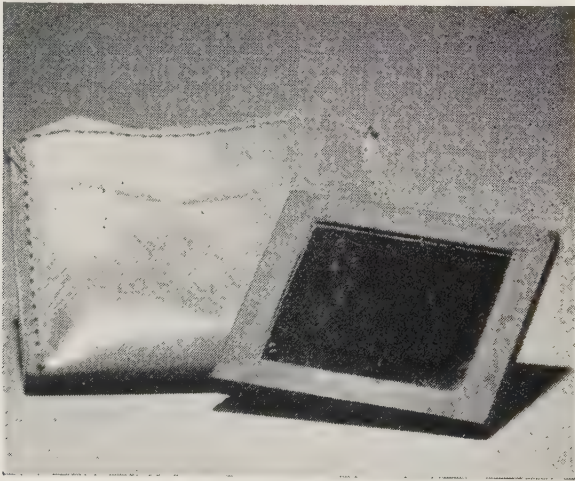

Figure 72
The Emerald Filter.

filter, for they fail to absorb the yellow-green absorbed by emeralds. Since demantoid garnet and zircon show a light red color through the filter and synthetic emerald appears red, these three gems are not separated from emerald. Most commonly seen substitutes for emerald are either triplets or glass. Both of these substitutes are usually separated from emerald by this test, but an

Color Filters and Fluorescence

occasional triplet appears red. The value of the emerald filter is limited because of the occasional exceptional green gems (listed above) other than emerald that appear red through the filter.

Synthetic blue spinel also appears red through the emerald filter in contrast to most genuine spinel and other blue gems which spinel imitates. However, natural spinel sometimes shows red through the filter. It is unwise to decide upon the natural or synthetic character of spinel on the basis of such a test, when more effective means of detection of the synthetic are available.



Figure 73
The G.I.A. Fluorescent Unit.

Fluorescence and Phosphorescence. When radiation shorter in wave length than visible light (ultra-violet or X-rays) falls upon certain materials, they have the property of transforming the invisible radiation to wave lengths of visible spectrum range. This property is called **FLUORESCENCE**. If the light emission continues after the object has been removed from the

source of excitation, the material is said to be PHOSPHORESCENT. Since the color of the fluorescence is often distinctive for certain gem stones, it is sometimes a certain test, but more often merely an indication of a gem's identity. Ultra-violet light sources of two wave lengths are most commonly used: certain materials will fluoresce under a radiation with a wave length of 2500Å., while others are more strongly affected by radiation of 3500Å. The 2500Å. radiation is furnished by a lamp



Figure 74

Testing a synthetic emerald for fluorescence in the ultra-violet radiation from a fluorescent unit.

known as the Mineralight.¹ Radiation of 3500Å. is provided by the G. I. A. Fluorescent Unit². Diamonds often fluoresce strongly under the 3500Å. light, but fail to show any fluorescence under the shorter wave length radiation. Diamond fluorescence is usually a light blue, but can be almost any color of the spectrum³. The grade of diamond known as the Premier always fluoresces very strongly, usually in a light blue color.

The display of strong fluorescence by corundum is considered an indication, though not proof, of synthetic origin, since genuine corundum may show fluorescence. Perhaps the most conclusive test based on fluorescence produced by either wave length is the distinction between synthetic and natural emerald. Syn-

1 Available at almost any lapidary or mineral supply house (\$35.00 and up).

2 Gemological Institute of America, Los Angeles.

3. GEMS AND GEMOLOGY, Spring, 1947, color plate facing page 396.

Color Filters and Fluorescence

thetic emerald fluoresces strongly in a red color similar to that it displays through an emerald filter, while the genuine material either fails to fluoresce or has an orange fluorescent color. The fluorescence of synthetic emerald is more marked under the 2500Å. radiation of the Mineralight. Since synthetic emerald has inclusions that closely resemble those of the natural, this test is most important.

Many triplets and garnet-and-glass doublets can be detected at one time by the use of the fluorescence test. Glass bases on garnet-and-glass doublets usually fluoresce a greenish-yellow under 2500Å. The nonfluorescent garnet stands out as a dark spot on the fluorescent background. The cement layers of some triplets fluoresce strongly, thus standing out clearly from the top and base of the imitation.

Chapter X

Synthetic Gemstones

A *synthetic* gemstone is one that has the same chemical composition, crystal structure, and, consequently, the same physical and optical properties as those of the natural gem it represents. Since its properties are the same as those of its natural counterpart, such important tests as the determination of refractive index and specific gravity are valueless in the detection of the synthetic. Fortunately, the only gemstones synthesized in commercial quantities are corundum, spinel, and the emerald variety of beryl. The synthetic zircon, garnet, topaz, amethyst, aquamarine and alexandrite of the trade are actually synthetic corundum or synthetic spinel. Since these stones do not have the same properties as the gems they represent, little difficulty is encountered in their detection. Synthetic corundum and synthetic spinel are also incorrectly sold as reconstructed gems. *Reconstructed* gems are those which are formed by sintering small pieces of the natural material. Rubies are reported to have been reconstructed at one time, but are rarely, if ever, seen in the American jewelry trade today. No other gems are manufactured by reconstruction at the present time, but so-called reconstructed ruby, sapphire, emerald, and many other gems are offered for sale in the trade. They are usually the common synthetic corundum or synthetic spinel, but glass imitations are not uncommonly sold as reconstructed gemstones.

Synthetic Gemstones

SYNTHETIC CORUNDUM

Manufacture. Synthetic corundum is produced by the Verneuil Process. It is now manufactured in the United States in large quantities, mostly by the Linde Air Products Company. Powdered aluminum oxide is dropped through an oxy-hydrogen



Figure 75

A Verneuil Oven with half-formed boule in position.

flame in which it melts before falling upon a slowly revolving ceramic rod. As the molten alumina solidifies, it assumes the crystal structure of natural corundum. The *boule* resulting from the accumulation of molten drops of aluminum oxide may weigh hundreds of carats. Because of the internal strain which is always present, the pear-shaped rough boule must be split lengthwise before cutting. If the aluminum oxide which comprises corundum or synthetic corundum is pure, the crystalline material is colorless. The addition of small percentages of certain metallic oxides lends color to the synthetic product. Synthetic

corundum is produced in most of the colors in which corundum is found in nature as well as many not occurring naturally. Although man must add slightly higher percentages of the metallic oxide coloring agents to produce colors comparable to those of



Figure 76
Stages of boule growth.

natural corundum, no significant changes in physical and optical properties result. The specific gravity of the synthetic is within .03 of 4.00, the average figure for natural corundum; the principal refractive indices are 1.762 and 1.770, and the birefringence is .008 — exactly the figures for nature's product. How, then, may the synthetic be detected?

DISTINGUISHING BETWEEN NATURAL AND SYNTHETIC CORUNDUM Conclusive Methods.

1. *The shape of inclusions* can be used to positively determine whether corundum is natural or man-made.

Synthetic Gemstones

a. Inclusions Characteristic of Synthetic Corundum.

Synthetic corundum is characterized by the presence of spherical gas bubbles. The bubbles are normally small, appearing as bright pinpoints of light when the gem is examined under magnification in dark-field illumination. The tiny spheres usually



Figure 77

A group of spherical gas bubbles in a curved pattern in synthetic ruby.

occur in groups or patches distributed unevenly throughout the gem, or confined to a single area. Occasionally a large spherical gas inclusion is found within a patch of tiny spheres. Bubbles are often arranged roughly in curves corresponding to the growth lines of the boule. It is not uncommon to find elongated gas bubbles resulting from movement of the viscous material during cooling. Such inclusions are circular in cross section in one direction, but elongated in the other. Some European synthetics contain irregular inclusions in addition to spherical bubbles, but,

since spherical inclusions are not found in natural gemstones, little difficulty is encountered in their identification. However, the detection of an irregular inclusion in a gemstone is no longer a proof of natural origin.

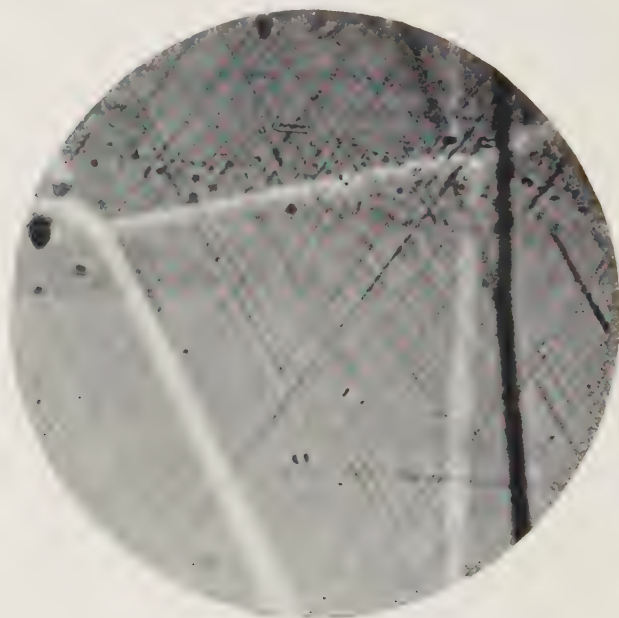

Photo by G.I.A.

Figure 78

"Silk" in three groups of parallel needles of 60 degrees

b. Inclusions which Characterize Natural Corundum.

Natural corundum may be positively distinguished from the synthetic equivalent by its inclusions. Natural corundum has angular inclusions in contrast to the spherical bubbles found in the synthetic. Characteristic of the genuine stone is the prevalence of "silk." "Silk" is a loosely defined term applied in the gem trade to long, thin, needle-like inclusions found in genuine corundum. It is usually formed by the growth of long, thin, rutile crystals, but it may consist of very long, negative crystals (hollow cavities with a crystal shape). "Silk" is arranged in

Synthetic Gemstones

corundum in three sets of parallel lines at 60° to each other. (See Figure 78.) The presence of "silk" is indisputable evidence of the natural origin of corundum, however, natural corundum sometimes contains no needle-like inclusions.

Other characteristic inclusions of natural corundum are tiny crystals of zircon, which stand out in bold relief because of the great difference in refractive index between corundum and zircon. The zircon usually appears as a point of bright light, surrounded by a "halo" of tiny black fractures. (See Figure 79.)

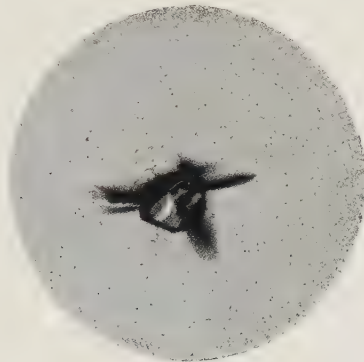

Figure 79

Zircon inclusions surrounded by a "halo" of tiny black fractures in sapphire.

Small octahedral crystals (eight sided solids resembling two pyramids base to base) of spinel are included in corundum, but small included crystals and rounded grains of corundum are more common. (See Figure 81.) Because inclusions of corundum have the same index as that of the parent material, they exhibit almost no relief.

Planes of liquid inclusions that have an angular pattern are also common in genuine material. The fairly regular pattern of liquid inclusions in ruby and sapphire have an appearance best likened to fingerprints. (See Figure 49.) Angular crystal and liquid inclusions are characteristic of material of a natural origin.

2. *Growth Lines.* The classification of growth lines is a reliable means of establishing the synthetic or natural origin of corundum.

a. *Synthetic corundum* is characterized by the presence of curved growth lines, or striae. As the synthetic boule is formed, the molten alumina flows outward from the center of the boule top. It is believed that a slight distortion of the crystal lattice of the doubly refractive material is the cause of the striae. The striae are visible when the finished gem is viewed perpendicular to the long axis of the original boule. They are most easily seen when the light source is reduced to pinpoint size, with the gem placed between it and the objective of the microscope. (See Figure 80). Color zones with the same curvature are also commonly encountered in the older synthetic corundum. The artificial gem material does not always exhibit curved striae, but the

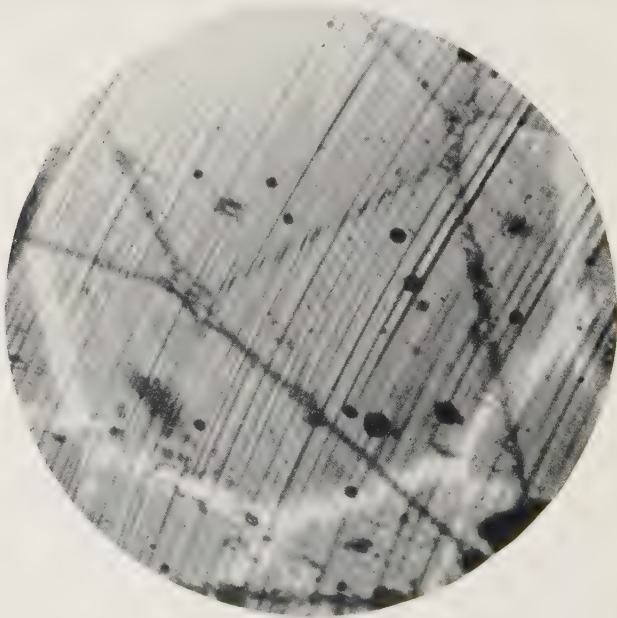

Photo by E. Gubelin

Figure 80

Curved striae and spherical bubbles with tails in synthetic corundum.

Synthetic Gemstones

gemologist should develop a technique for magnification that will resolve curved striae whenever possible. The production of synthetic corundum free of inclusions is increasing; hence, it is becoming more important to detect striae with optimum efficiency.

b. *Natural corundum* exhibits color zoning, inclusions arranged parallel to straight growth lines, and striae due to repeated twinning. Both color zones and inclusions parallel straight growth lines and intersect at angles of 60° , but the



Figure 81

Rounded corundum grains included in sapphire.

striae resulting from repeated twinning continue as straight lines entirely across the cut gem. Corundum often has irregular color distribution, with one growth layer strongly colored and the next almost colorless. This effect is rarely apparent unless the gem is observed parallel to the long axis of the original crystal (parallel to the growth lines). Although the zoning or the striae of natural corundum is usually more distinct than that of its syn-

thetic counterpart, it is often necessary to subject natural corundum to the same careful scrutiny before arriving at a definite decision as to its identity.

Burma rubies often show an irregular color distribution that seemingly bears no relation to the growth of the crystal. This patchy color distribution is characteristic of the Burma ruby.

INCONCLUSIVE EVIDENCE OF THE SYNTHETIC OR NATURAL ORIGIN OF CORUNDUM.

There are many other characteristics that could not be considered definite proof, but are indications of origin.

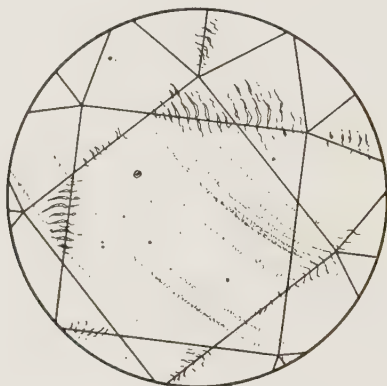

Figure 82

Typical cracks at facet edges, caused by rapid polishing; with spherical bubbles and curved striae in synthetic corundum.

1. Because synthetic corundum has a negligible intrinsic value, little care goes into its fashioning. The heat generated by polishing synthetics too rapidly frequently causes cracks to appear at facet junctions. (See Figure 82.) Polishing or wheel marks on the surface of the facets are commonly seen in the synthetic. Cracks along the facet junctions and other evidence of poor polishing can be considered an indication of synthetic origin.

Synthetic Gemstones

2. Splitting the boule lengthwise to ease internal strain produces rough from which large gems are most advantageously cut when the table of the gem is placed parallel to the length of the boule. In this position, the optic axis is more or less parallel to the table, a condition which allows dichroism to be observed through the table. Natural rough, on the other hand, lends itself to the greatest preservation of size and beauty in the cut gem when the table is perpendicular to the optic axis. Thus, in most cases, no dichroism can be seen through the table of a natural stone.

3. In those hues of synthetic and natural corundum which fluoresce under ultra-violet radiation, the synthetic exhibits much stronger fluorescence.

4. The color of synthetic ruby is usually orangy-red, rather than the violetish-red of fine natural ruby.

5. If corundum remains equally light in all positions upon rotation in the dark position of the polariscope or polarizing microscope, natural corundum is suggested since such an effect is caused by repeated twinning.

These five indications should NEVER be considered proof of natural or artificial origin.

SYNTHETIC SPINEL

The chemical composition of both natural and synthetic spinel is magnesium aluminum oxide. There is a difference between synthetic spinel and the other synthetic gems in that the basic formula of the natural mineral is not always strictly adhered to in its synthesis. In natural spinel, the ratio of magnesium oxide to aluminum oxide is one to one. This is usually true of the synthetic material, but in some cases it is made with a ratio as high as five parts of aluminum oxide to one part magnesium oxide. Where more aluminum oxide has been used, the synthetic material will be higher than the natural mineral in refractive index and specific gravity. In the extreme case, with the ratio at five to one, the refractive index may reach 1.74 compared to the usual 1.72 of the natural material and most syn-

thetic spinel. The hardness of both synthetic and natural spinel is eight, but an excess of aluminum oxide may somewhat increase the hardness of the synthetic. The toughness of synthetic spinel is inferior to that of the natural, since the synthetic boule is badly strained.

Conclusive Identification of Synthetic and Natural Spinel.

Proof of *synthetic origin* is found in the presence of spherical gas bubbles. Gas filled spheres in synthetic spinel are usually smaller and much less numerous than in synthetic corundum. Curved striae are not found in synthetic spinel, because the material is singly refractive. Another type of inclusion characteristic of synthetic spinel is a "bread crumb" inclusion. Un-

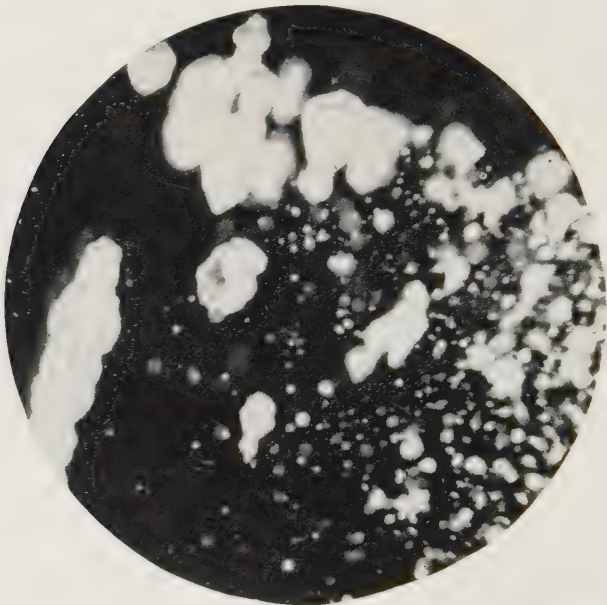

Photo by Gubelin

Figure 83

Spherical and pointed gas bubbles in synthetic spinel.

Synthetic Gemstones

der dark-field illumination this type of inclusion appears as a bright porous spot that seems to have been caused by the coalescence of several small bubbles in close proximity. The presence of very strong anomalous double refraction is invariable in synthetic spinel. Its appearance in the polariscope, when the instru-



Figure 84

“Cross-hatched” appearance caused by anomalous double refraction in synthetic spinel.

ment is in its dark position, has been called “cross-hatched,” i.e., alternately dark purple and light patches are seen within the gem. (See Figures 84 and 85.) This lattice-work appearance in the polariscope can be considered proof of synthetic manufacture. While spinel of natural origin sometimes shows anomalous double refraction, it does not assume a “cross-hatched” appearance.

Spinel can be proved to have a natural origin by the presence of angular inclusions. The common inclusions in natural spinel

are small octahedra of spinel, which are usually scattered throughout the stone, but may occur in planes parallel to the octahedral faces of the crystal. Other crystal and liquid inclusions are often present.

Indications Suggesting Synthetic or Natural Spinel.

1. Signs of rapid polishing, such as striations on facets left

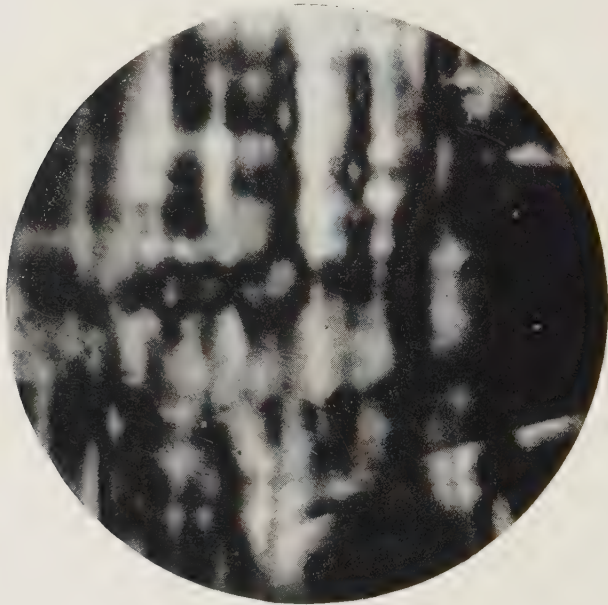

Figure 85

"Cross-hatched" appearance caused by anomalous double refraction in synthetic spinel.

by the lap and irregular cracks along facet edges, indicate synthetic material. Careful fashioning suggests natural spinel.

2. Synthetic spinel may have a higher specific gravity and refractive index than the natural gem quality spinel. Rose colored synthetic spinel usually has a specific gravity of slightly less than 3.75, and some synthetic blue spinel has a specific gravity

Synthetic Gemstones

of 3.7, compared to the specific gravity of 3.6 of natural spinel.

3. The color of synthetic spinel seldom bears any close resemblance to the colors found in natural spinel, since the natural gem is usually darker in color.

4. In many cases, ultra-violet radiation will actuate in synthetic spinel a fluorescence of a color never observed in similar colors of natural spinel. This is especially true of blue or green synthetic spinel which shows very strong red fluorescence under ultra-violet radiation, while blue or green natural spinel rarely exhibits such fluorescence.

Indications alone are insufficient to make an identification. No identification of synthetic or natural spinel should be made unless based on observation of characteristic inclusions, or a "cross-hatched" appearance in the dark position of a polariscope

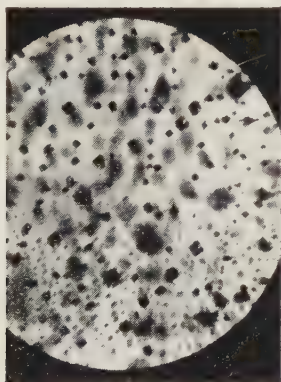

Figure 86

Numerous octahedral spinel crystals, which typify natural spinel.

SYNTHETIC EMERALD

Emeralds were first made synthetically by a secret process developed by the I. G. Farbenindustrie in Germany about 1935. The Germans were unable to grow large gem-quality crystals of synthetic emerald by this process. Although the color of the syn-

thetic product was not as fine as that of the best emeralds, the inclusions closely resembled those of natural emerald. The synthetic emerald produced in Germany had slightly lower physical



Photos by G.I.A.

Figure 87

Wisp-like pattern of liquid inclusions in synthetic emerald under 20X.

Figure 88

Synthetic emerald liquid inclusions under 100X.

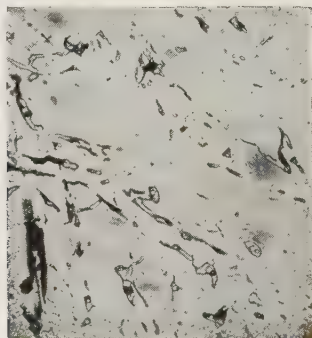

Figure 89

Tiny tabular square crystals in Colombian Emerald.

Synthetic Gemstones

and optical properties than those of natural beryl, but X-ray photographs revealed that the crystal structure was identical.

About 1940, a San Francisco chemist, Carroll Chatham, developed a process for the manufacture of synthetic emerald by which he was able to produce large crystals with the deep blue-

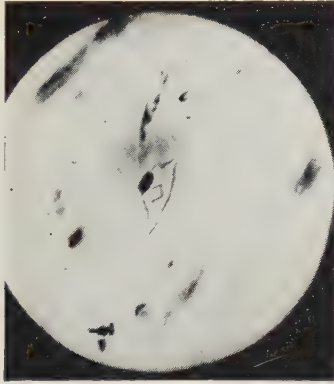

Figure 90

The diamond-shaped tabular crystal in this three-phase inclusion in an emerald indicates Russian origin.

green color of fine emerald. The early American synthetic had much the same appearance under magnification as the German-made synthetic emerald in that wisp-like markings were the most common inclusions. These were made up of large numbers of tiny liquid inclusions. (See Figure 87.) The characteristic wisp-like pattern of liquid inclusions made the detection of synthetic emerald a simple matter. Further developments by Mr. Chatham have made identification a much more difficult task. The more recent material often comes in larger sizes (cut gems of nearly one carat) with a color closely resembling fine Columbian emeralds. The synthetic gems now coming from the Chatham labora-

tory have many included emerald crystals within the parent material. The wisp-like liquid inclusions are sometimes present, and, if so, can be used as a basis for identification. Unfortunately, however, they are often entirely missing.

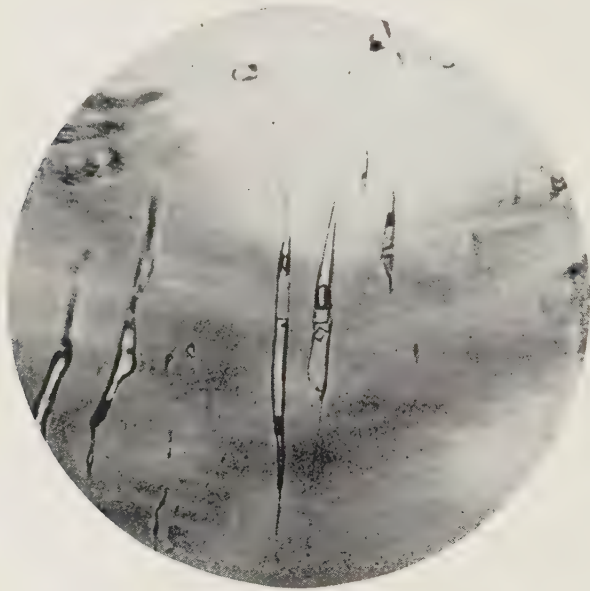

Photo by E. Gubelin

Figure 91

Three-phase inclusions in emerald with a square crystal, indicating Colombian origin.

How to Distinguish Between Natural and Synthetic Emerald. Genuine Colombian and Russian emeralds, often show three-phase inclusions that are never present in the synthetic. Three-phase inclusions refer to those that contain liquid, gas, and solid material. Russian emeralds have tiny diamond-shaped crystals in the cavities with liquid and gas (See Figure 90), while Colombian emeralds have square crystals in the cavities (See Figures 89 and 91). Pyrite crystals are often included in natural emerald, but never in the synthetic. The presence of

Synthetic Gemstones

three-phase inclusions or pyrite crystals identifies natural emerald, but their absence is NOT proof of synthetic origin. Fortunately, there is a positive method of distinguishing between synthetic and natural emerald. Under ultra-violet radiation of both 2500Å. and 3600Å., synthetic emerald fluoresces strongly, while a genuine emerald always fails to do so, although a weak orange fluorescence in the natural material is occasionally seen. The 2500Å. radiation is best for the fluorescence test. The color of the fluorescence produced by ultra-violet radiation on the synthetic is a red similar to that seen when an emerald is examined through an emerald filter.

Chapter XI

Doublets, Triplets, Foil Backs and Imitations

Assembled Stones

Description. Doublets, triplets and foil backs are commonly used substitutes for many valuable gems. The term *assembled stones*, used by Robert M. Shipley to include all three, will be used to designate these substitutes.

Doublets are made by joining two pieces of material with a colorless cement. In a garnet-and-glass doublet, the glass is usually fused to the garnet crown.

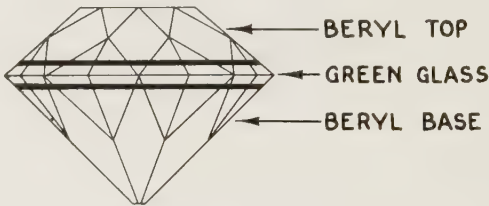

Figure 92

Genuine triplet.

Triplets are constructed by joining two pieces of material with a cement that gives the stone its color (Figure 92).

Foil backs are made by attaching a mirror-like back to the stone to enhance a star, or to give either brilliancy or color, or both.

Classification. Assembled stones are classified according to the proportion of genuine material in their makeup.

In a *genuine doublet or triplet* both gem portions of the stone

Doublets, Triplets, Foil Backs and Imitations

are genuine material of the species which the stone imitates. A *genuine beryl triplet* is made by cementing two pieces of light colored beryl with an emerald-colored cement.

A *semi-genuine doublet or triplet* contains only one natural portion of the species it imitates. Colorless beryl, green cement, and colorless quartz were used to form a triplet once common to the jewelry trade.

A *false doublet, triplet, or foil back* contains one or more portions of natural material, but the final product does not represent the gem used in the genuine portion. If star quartz with a mirror base is made to represent star sapphire, the result is a false foil back. A garnet top, red glass-backed doublet made to represent ruby is a false doublet. Two pieces of quartz held by a green cement to lend an emerald color, form a false triplet.

If no part of the assembled stone is genuine, it is simply called glass.

Types of Assembled Stones Commonly Encountered.

Since the appearance in the market of synthetic corundum and synthetic spinel, many of the assembled stones formerly used in quantity to represent the more valuable gems are no longer manufactured. Three varieties of assembled stones—the OPAL DOUBLET, EMERALD TRIPLET and QUARTZ BACKED BY A MIRROR TO

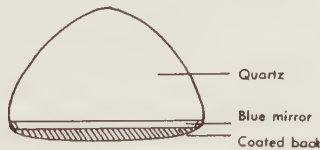

Figure 93
Star quartz foil back.

REPRESENT STAR SAPPHIRE—are now the most commonly encountered types of assembled stones. GARNET-AND-GLASS DOUBLETS in all colors; representing emerald, ruby, sapphire, aquamarine, and topaz, once produced in such large numbers, are still commonly seen. The garnet top is almost always almandite, but since

the final product takes on the color of the glass back, the color range of this imitation is almost unlimited.

Detection of Doublets and Triplets. There are many tests which may be used for the detection of doublets and triplets. Probably the most effective is one which reduces the reflections from the facets, and enables the observer to examine the interior of the gem clearly.

Immersion is the best means of reducing facet reflections. The two pieces of a doublet, the plane or planes of separation between the stone portions, or the colored cement of a triplet are usually evident when the stone is immersed.

The red ring test is a very simple means of detecting a garnet-and-glass doublet if the stone is of a color other than red. If the stone is placed table down on a piece of white paper, a red ring close to the girdle, produced by the garnet crown, appears.

Under careful observation in reflected light even a novice may notice a distinct difference in luster between the portions of a garnet-and-glass doublet, with garnet revealing much higher luster than glass. In addition, since garnet caps on garnet-and-glass doublets seldom cover the whole crown (Figure 94), a division line is usually evident on the bezel facets.

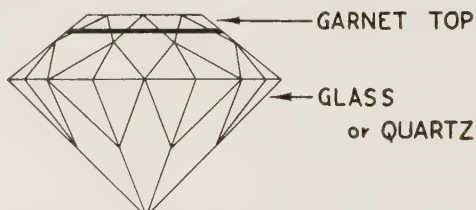

Figure 94
False doublet.

A *refractive index reading*, taken on the crown of the stone and on a back facet, may reveal a doublet or triplet by a large difference in the readings.

The **FLUORESCENCE TEST**, which depends upon ultra-violet radiation of 2500\AA . is a new method of doublet and triplet identi-

Doublets, Triplets, Foil Backs and Imitations

fication recently developed by the staff of the Gemological Institute of America. When stones are placed under a radiation of 2500Å. the cement used in the colored layers of triplets often fluoresces very strongly, while the tops and backs do not. Thus the cement layer stands out very clearly, establishing the nature of the assembled stone. The test is also effective for garnet-and-glass doublet detection. Because the glass back of a garnet-and-glass doublet usually fluoresces a greenish-yellow and the garnet top fails to fluoresce, the doublet's back surfaces appear to be covered with greenish-yellow powder, while only a dark spot is visible in the position of the garnet crown.

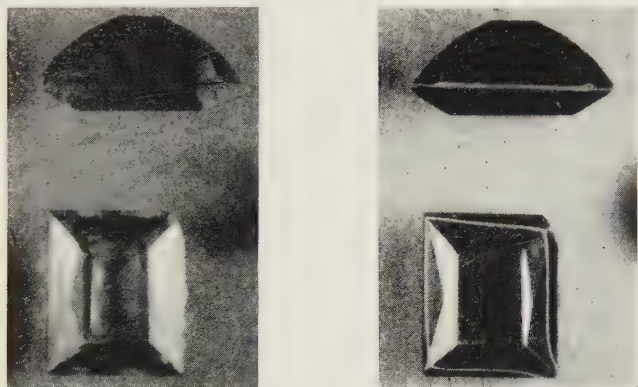

Figure 95

Triplet in ordinary light.

Triplet under 2500Å radiation.

The most important use of the fluorescence test is for a rapid check on a large number of gems. No further tests would be necessary for those gems which fluoresced as described above. Since the cement layer of triplets and the glass in garnet-and-glass doublets sometimes do not react to ultra-violet radiation, failure to fluoresce in the manner described is not proof that an unknown gem is not a doublet or triplet.

Magnification may resolve the separation plane of a doublet or triplet. Often simple observation directed parallel to the

girdle of the stone shows a difference in color between the two portions.

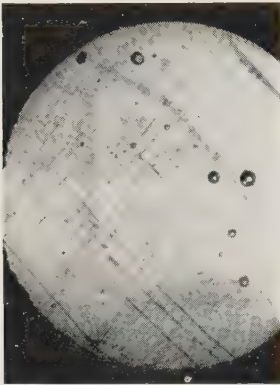

Figure 96

Garnet-and-glass doublet showing both "silk" and spherical gas bubbles.

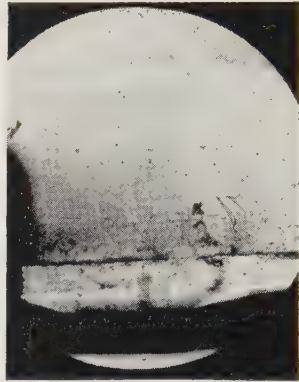

Figure 97

Garnet-and-glass doublet showing the separation plane distinctly.

Detection of Foil Backs. Foil backs are detected more easily than other imitations — the presence of the foil is difficult to conceal. Faceted gems that have foil covering the back facets are unmistakable. Star quartz is backed by a foil mirror to enhance the star and to lend a color similar to star sapphire or ruby. The mirror is covered by a protective cement layer, but the difference between the quartz and the cement is so apparent that there is no possibility of confusing the imitation with star ruby or star sapphire.

Imitations

The classification *imitation* includes all noncrystalline materials which are wholly produced by an artificial process in an attempt to imitate genuine stones in appearance.

Doublets, Triplets, Foil Backs and Imitations

Imitations Commonly Encountered. The imitations most commonly encountered are *glass*, *imitation foil backs* (glass fashioned as gems, then backed by foil), *plastics*, and *imitation pearl*. By far the most important imitation is *glass or paste*.

Glass. Glass imitations vary from molded stones used in the cheapest costume jewelry to types which, through skillful manufacturing methods, very closely imitate the gems they represent. The natural gems which glass best imitates are chalcedonic quartz, beryl (emerald and aquamarine), jade, turquoise and topaz. It is less effective in imitations of corundum, diamond and zircon.

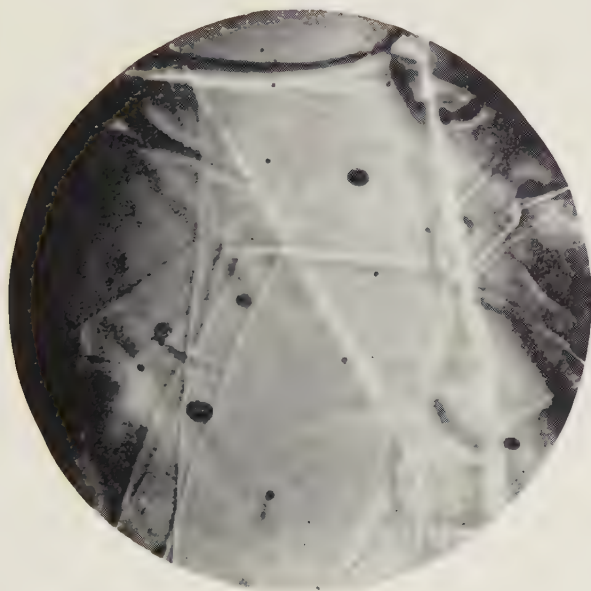

Figure 98

Swirl-marks or flow lines with spherical bubbles in glass.

Glass used in imitation of gemstones is composed of silicon oxide (the composition of quartz) combined principally with an

alkali, such as calcium, sodium, or potassium, or with lead, boron, thallium, aluminum, or barium oxides, depending upon the properties desired. Imitations vary from silica glass, which is almost entirely silica, to strass glass, which contains less than forty percent silica and more than fifty percent lead oxide. The addition of lead oxide considerably increases the refractive index, specific gravity and fire of the glass.

The range of colors which can be produced in glass is almost unlimited, and the colors achieved often very closely approach the colors of the natural gems the glass represents. Gold chloride is used in glass that most nearly reproduces the color of ruby. Yellow glass is produced by the addition of silver oxide or chloride and antimony. Impure carbon is sometimes added to glass with manganese to produce a golden yellow, while cobalt oxide is used to produce blue.

Detection of Glass. The variation in quality of glass used to imitate gemstones is such that some types may be identified at a glance while others may be detected only after a series of careful tests.

A distinctive vitreous or glassy luster on fracture surfaces is sometimes sufficient proof of a glass imitation of an opaque gemstone. Glass imitations of turquoise and chalcedony are easily detected by the glassy luster of fracture surfaces.

A feeling of warmth in the stone as it is held in the hand is an indication of glass. In contrast, a natural or synthetic crystalline material (a better conductor of heat than glass because of its crystal structure) is cool to the touch.

A molded appearance of the back facets is easily detected in the cheaper varieties of glass imitations which are polished only on the crown. Facet junctions in molded glass are not as sharp as they would be in polished materials. The facet surfaces are not flat, but usually have a slight depression at the center.

Too much fire for the natural gem may be noted in glass imitations of corundum, emerald and topaz, as well as other gems of low dispersion.

Doublets, Triplets, Foil Backs and Imitations

Too little dispersion marks a glass imitation of diamond or zircon.

The action of a drop of water may distinguish glass. Place a small drop of water on the stone's surface with a toothpick or a match stick. On glass or any amorphous gem material the drop will spread, while on crystalline material the drop will retain its shape.

The usual glass imitation has either *spherical bubbles* or *elongated bubbles* similar to those of viscous liquid which is being stirred.

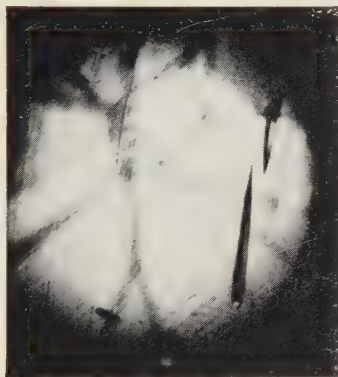

Figure 99

Swirl-marks and greatly elongated gas bubbles in molded glass.

Glass often shows characteristic *flow lines*, so named because they resemble light effects on viscous flowing liquids, such as molasses. These may have been caused by improper mixture of the materials which comprised the glass melt, or by disturbance of the melt as it cooled. In some instances, insoluble material of an angular nature is added to the melt to simulate inclusions characteristic of genuine gems. Such inclusions are invariably accompanied by numerous spherical and elongated gas bubbles.

Irregular curved color lines often serve to distinguish glass imitations of nontransparent gemstones such as turquoise and jade.

Occasionally glass appears to be *free of inclusions*, even under magnifications of 100 power or more.

The *refractive index and specific gravity* of a glass imitation are rarely close to the readings of the gem imitated in color.

Glass, an amorphous substance, is *singly refractive*. It may occasionally be strained enough to show an anomalous double refraction, but rarely as strong as that of synthetic spinel. A glass imitation of a natural, singly refractive gemstone will never have both the same refractive index and the same specific gravity as that of the genuine, though it may have one or the other.

A glass imitation of a natural, doubly refractive gemstone may have approximately the same refractive index and the same specific gravity as the gemstone it imitates (quartz, beryl or topaz), in which case the singly refracting character of the glass will identify it.

Glass used for gem imitations has a normal refractive index range from 1.42 to 1.70, and its specific gravity may be as low as 2.2 and as high as 4.2.

The *hardness* test can be used whenever tests have proceeded to the point at which the only remaining possibilities are glass and some other singly refractive gem other than opal.

The hardness of glass is usually $5\frac{1}{2}$ or less. Some types of glass usually blue or green, may be 6 in hardness, though most of the lead glasses used in gem imitations are softer than window glass. A steel file will scratch even the harder glasses.

Plastics. Plastic gem imitations, long used to imitate amber, ivory and opaque gem materials, are finding increasing use in a transparent form for costume jewelry.

Detection. Plastic imitations are easily identified by their low specific gravity and hardness. All of the common plastics used as gem imitations have specific gravities below 1.59, the density of Carbona. A properties table for plastics follows:

	R. I.	S. G.
Plexiglass and lucite.....	1.50	1.18 ($\pm .01$)
Bakelite	1.61 ($\pm .05$)	1.25-1.55
Polystyrene	1.63 ($\pm .04$)	1.05

Pearl imitations are described in Chapter XII.

Chapter XII

Pearls, Cultured Pearls and Imitations

The pearl, so unlike other gemstones in appearance and origin, requires special methods of determination. Since the cultured pearl was first introduced into the jewelry trade, the most difficult determination facing the jeweler has been the distinction between natural and cultured pearls. While natural and cultured pearls are easily distinguished from imitations, their separation from one another is exceedingly difficult.

The difficulty encountered in the distinction between the pearl and its reproduction is due to the similarity of the nature of cultured pearl to natural pearl.

Natural Pearl. Pearl is formed within a mollusc which deposits a substance called NACRE around an irritant that has found its way into the organism. The irritant may be a microscopic grain of foreign matter such as sand, or possibly a disease or parasitic growth suffered by the mollusc. Often no identifiable source of irritation is found when a natural pearl is sectioned. When the irritant finds its way into the mantle of the animal, NACRE is added layer by layer. NACRE is formed by a web-like deposit of conchiolin (a bone-like material) the spaces between which are filled with tiny crystals of aragonite (the orthorhombic form of calcium carbonate) which are oriented with the long direction perpendicular to the layer. In other words, the tiny crystals are arranged radially about the pearl. (This structure is shown in Figure 100).

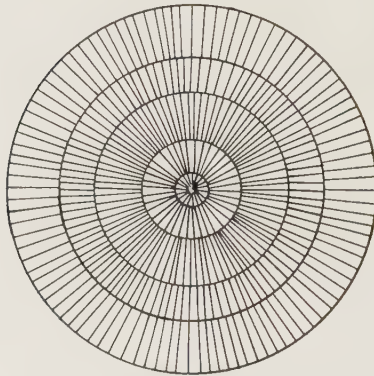

Figure 100

Schematic cross section diagram of a natural pearl.

Cultured Pearl. The cultured pearl is formed by introducing a large spherical bead of mother-of-pearl (usually taken from the shell of a fresh water bi-valve) into the mantle of the mollusc *Meleagrina Martensi*. Formerly the large bead was sewed into a sac in the mantle tissue. More recently, the bead has simply been placed within the shell upon the mollusc with a loose piece of mantle tissue separating the bead from the shell. The life of the Japanese pearl-bearing mollusc is only about seven to ten years. The period of major nacre production, however, is only about four years, during which a nacre layer of approximately one-half millimeter or less is deposited. Rarely.

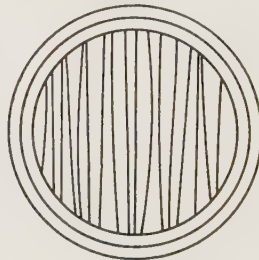

Figure 101

Cross section diagram of a typical cultured pearl.

Pearls, Cultured Pearls and Imitations

cultured pearls with a nacreous shell of one-millimeter or even more are found. Often the nacre of a cultured pearl will be irregular, with a greater thickness on one side or with a rough, uneven surface. It has often been stated that seed pearls are used as irritants. Claims have also been made that cultured pearls have been produced commercially by simply introducing an irritant into the mollusc bed, rather than into individual mollusc. No proof has been offered to give credence to either claim.

The Distinction Between Natural and Cultured Pearls.

Since the surface material of natural and cultured pearl is the same, having been deposited by a pearl-bearing mollusc, it is difficult to arrive at a positive identification of an undrilled pearl. There are many jewelers who claim the ability to distinguish between cultured and natural pearls on sight. Their methods are usually based on the difference in appearance between pearls from Japanese molluscs and those from the molluscs from other sources. It is true that Japanese pearls are more likely to have a greenish body color than other pearls. However, of the men who have dealt with pearls for a lifetime, few are willing to depend upon visual examination in a decision that will make a difference of thousands of dollars in the valuation of a necklace. Too often, mistakes result from any other test than a scientific one. Of the several tests described on the following pages, only two can be regarded as conclusive. The reaction of a natural pearl in the double-mirror method is proof of its identity. The X-ray diffraction method is also reliable. The single-mirror method and the X-radiographic method are both fairly reliable. The other tests described serve only as indications in the identification of natural or cultured pearls.

Simple Pearl Tests

Specific Gravity The large mother-of-pearl bead that forms the core of a cultured pearl is usually fashioned from the shells of fresh water bi-valves. The fresh water shell commonly used has a greater specific gravity than natural pearl. If a solu-

tion of the correct density is prepared, by far the larger proportion of natural and cultured pearls may be accurately separated. To prepare such a solution, dilute pure bromoform (obtainable in an alcohol solution at almost any chemical supply house) with grain alcohol or acetylene tetrabromide until Iceland Spar (calcite) is suspended. A few more drops of bromoform are added to just bring the calcite to the surface.

Caution. Bromoform is usually sold in an alcohol solution that has a density of about 2.5, instead of 2.9, the density of the pure material. To wash out the alcohol, pour the bromoform into water (alcohol and water are miscible, but bromoform and water are not and decant the water carefully several times to bring the bromoform to its pure state.

In the solution prepared by the dilution of pure bromoform in the manner described, natural pearls will usually float, and cultured pearls normally sink. Eighty per cent of natural salt water pearls will float in a solution with a density of 2.713, and ninety per cent of cultured pearls will sink.*

Candling. A second simple test which often gives indefinite results, but which is helpful in the identification of a complete pearl strand, is candling. Candling requires the intense illumination of the pearl, preferably in a darkened room.

In the cultured pearl, the parallel layers of a prominent mother-of-pearl core can be seen as lines across the pearl. The test is not reliable since some cultured pearls fail to show stripes, and cracks in a natural pearl can cause a striped appearance in intense illumination. Candling of the normal natural pearl shows only a decrease of light transmission from periphery to center. The edges of the natural pearl appear light and the center dark.

To candle a pearl effectively, an intense — but well shielded light source is essential. An opaque shield should completely cover the light except for an opening about one millimeter over which the pearl is placed. It is necessary to turn the pearl

*Anderson, B. W.; Payne, C., *GEMMOLOGIST*, May, 1939.

Pearls, Cultured Pearls and Imitations

slowly in the light beam to find the "stripes" in a cultured pearl or to be certain that such a structure is not visible. While candling is unreliable in the testing of a single pearl, it furnishes an indication as to the identity of a strand.

Magnification. A test often used by jewelers because of its ease of application is magnification of the walls of the drill hole of a pearl with a loupe or microscope. The brown conchiolin separation layer is often visible between the mother-of-pearl core and the layers of nacre. Care must be taken to light the drill hole adequately so that the brown layer is visible, if present. Unfortunately, while the presence of such a layer is a good indication of cultured pearl, it is not proof, since similar phenomena occur in natural pearls and are not always present in the cultured pearl.

Appearance. The "gelatinous" appearance and the greenish body color is a good indication of Japanese pearl, and, thus of cultured pearl. Before World War II, however, cultured pearls were produced in the East Indies, where the external nacre characteristics were unlike those of the Japanese product. Still, to the experienced pearl man, the Japanese characteristics are good indications of cultured pearl even though the lack of such characteristics is no longer truly indicative of natural pearls. Black welts, not common in natural pearls, have long been considered suggestive of cultured origin. The insertion of a large mother-of-pearl bead sickens the mollusc, which accelerates conchiolin production, producing the welts.

More Conclusive Pearl Tests

Pearl Endoscope and Pearloscope. The pearl Endoscope and the Pearloscope are efficient and exact instruments for the determination of the origin of drilled pearls. There are several methods of identification that utilize metal needles with mirrors polished at 45° angles to their length, principal ones being the single mirror method and the double mirror method described below. All of them may be applied with the Endo-

scope and the Pearloscope. The Pearloscope has an efficient pearl candler in addition to the features of the Endoscope. The needle is mounted in a vertical position on the Pearloscope in contrast to the horizontal needle on the Endoscope.

Single Mirror Methods. There are two single mirror methods. THE FIRST is used to examine the walls of the drill

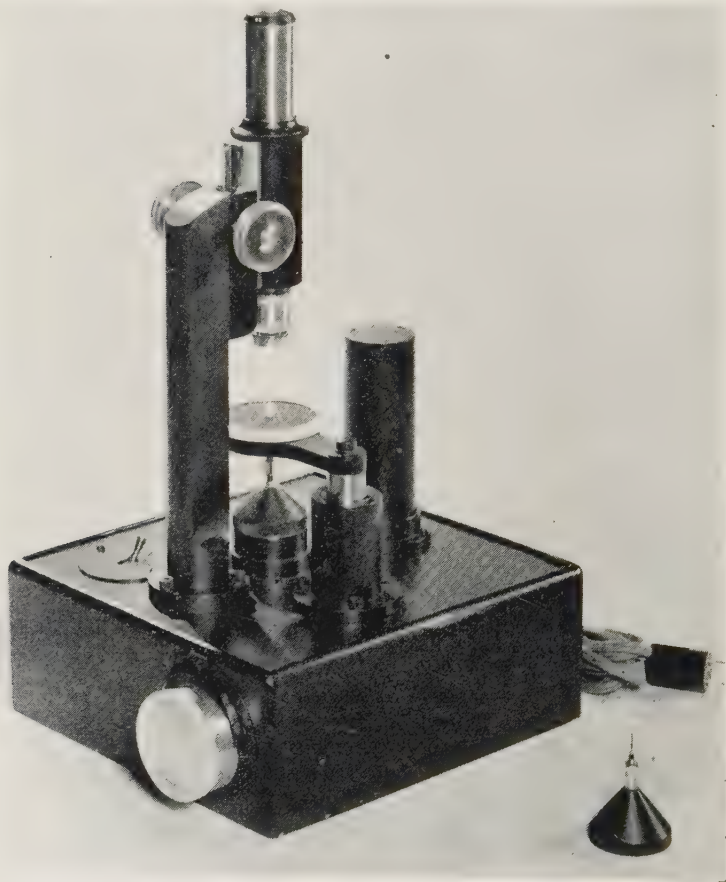

Figure 102

The new G.I.A. Pearloscope for drilled pearl identification.

Pearls, Cultured Pearls and Imitations

hole by directing an intense light source at the pearl from the side. After passing through the pearl to the mirror the light is reflected to a microscope focused on the mirror. This allows the microscopist to examine the walls of the drill hole. In a natural pearl the observer can see the concentric rings layer after layer to the center of the pearl, accompanied by a gradual decrease in the light intensity. In the examination of a cultured pearl, the rings end abruptly as the mother-of-pearl core starts, and the light decreases sharply.

The **second single mirror method**, much less conclusive, is essentially the opposite of the first method. In place of being used to examine the walls of the drill hole, the mirror is used to direct intense illumination against the walls, with the observation being directed from the side of the pearl without magnification. If the pearl has a mother-of-pearl core, the intense light is carried by repeated reflection along the parallel layers of the mother-of-pearl up to the nacre rings, where it gives an effect similar to chatoyancy (the "cat's-eye" effect). This effect is seen



Figure 103

Mounting a pearl on an endoscope needle.

only in the cultured pearl, but not all cultured pearls show the phenomenon distinctly. Natural pearl, which retains the light within the inner rings by reflection, has an even illumination in contrast to cultured pearl.

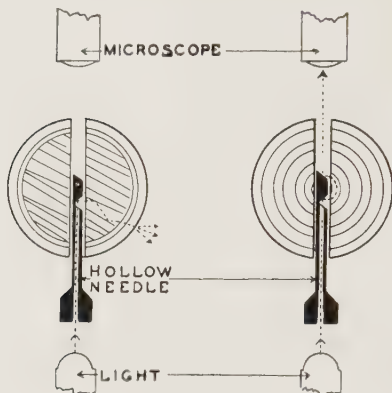

Figure 104

*Left. Schematic diagram of the reaction of a cultured pearl in the double mirror testing method of the endoscope or pearloscope.
Right. Reaction of a natural pearl.*

The Double Mirror Method. The double mirror method employs a hollow needle which has two mirrors inclined at 45° to the length of the needle and at 90° to each other. When carefully used this test is almost 100 per cent effective. One pearl in thousands fails to lend itself to positive identification. The hollow needle is mounted before an intense light source so that the light is directed through the needle to the first mirror surface from which it reflects to the wall of the drill hole. If the pearl is cultured, the light will be carried along between the parallel layers until it passes through the thin nacre ring. If the pearl is natural, the effect is different. A microscope is directed through the end of the drill hole opposite to the needle end, and directed upon the second mirror. When the light strikes the walls of the drill hole in a natural pearl, it is carried around the pearl within the ring of nacre it first strikes by total reflection, much in the manner that light is carried from end to end of a curved lucite rod. The light carried within the concentric ring strikes the second mirror and is reflected as a bright flash to the microscope and to the eye of the observer. Although this

Pearls, Cultured Pearls and Imitations

method will, on very rare occasions give indefinite results, it is never inaccurate when a positive flash is observed.*

X-RAY METHODS

The various X-ray methods will not be described in detail for such equipment is not easily available and is too expensive for the usual gemological laboratory. However, many jewelers send pearls to laboratories for identification by X-ray, so some mention of the basis for such tests should be included here.

X-ray Diffraction. Prismatic crystals of aragonite are arranged radially around the center of the pearl with their length at right angles to the surface. (See Figure 100). In the cultured pearl, the prismatic crystals are also perpendicular to the layers, but the layers in the core are straight and parallel, not spherical and concentric as in the natural pearl. Only the thin outer covering of nacre has the same arrangement as natural pearl. (See Figure 101). When the natural pearl is placed in the path of the X-ray beam, with the beam passing through the center of the pearl, the rays are traveling parallel to the length of the crystals. Because of the atomic arrangement of aragonite, the resulting

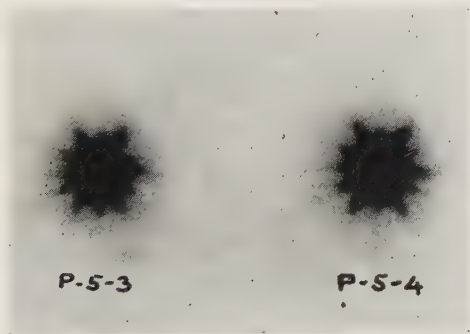

Figure 105

Hexagonal diffraction patterns from natural pearls.

*Anderson & Payne—*ibid.*

diffraction pattern will have a six-fold symmetry (what appears to be an hexagonal pattern of spots. (See Figure 105). The only direction in which the cultured pearl can give a similar pattern is in the one position ($\pm 37^\circ$), where the parallel crystals of the mother-of-pearl core are parallel to the X-ray beam. To avoid

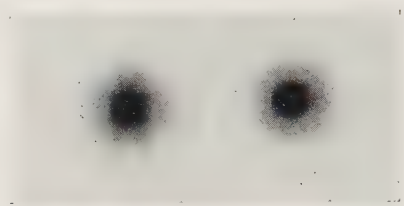

Figure 106

Four-fold symmetry in cultured pearl diffraction pattern.

this unlikely chance, it is safest to take a second X-ray photo after rotating the pearl 90° , if the first pattern shows a hexagonal pattern. If the cultured pearl is in any other position this will give a pattern with four-fold symmetry. (See Figure 106). The X-ray diffraction method is exact and reliable. It has the major drawback of requiring some length of time for each picture (one to five hours), with only from one to twelve pearls being photographed at a time.

Radiographic Methods. There are X-ray methods that allow whole strands of pearls to be examined at once, with the whole process requiring but a minute or two. In this test, the pearl strand is held before a large X-ray beam, directed against a fluorescent screen or a photographic plate. The radiographic photographs are similar to those taken of teeth by the dentist. This method depends upon the difference in transparency to X-rays of the conchiolin layer around the mother-of-pearl core and the nacre coating of the cultured pearl. In a natural pearl the absorption of X-rays is dependent on thickness, since it is a homogeneous object. The resulting radiograph exhibits nothing more than a circular area decreasing continuously in darkness toward the center, while the cultured pearl usually shows a very

Pearls, Cultured Pearls and Imitations

definite dividing line at the separation between core and nacre, due to the extreme transparency of the conchiolin layer about the mother-of-pearl core. Although this method does not give positive results with every pearl, a stand which shows 75 to 90 per cent cultured pearls is assumed by some pearl men to be entirely cultured. Some cultured pearls have a thin enough nacre layer to give the appearance of natural pearl, and natural pearls occasionally show the light ring characteristic of cultured ones, so that the radiographic method is not reliable with single pearls.

Pearl Imitations

Much improvement has been made recently in the appearance of pearl imitations marketed extensively in the United States. The imitation pearl is usually one of two types; wax-filled glass spheres, or solid glass spheres. Both are given a pearl-like luster by dipping the spheres into "essence d'orient," an ammonia solution of fish scales. The similarity in appearance of these imitations to natural pearls is remarkable.

Wax-filled Imitations. Careful examination of the drill hole will show the character of wax-filled imitations. The edges of the hole have a glassy character — a vitreous luster — and a rougher appearance than the natural or cultured pearl. Wax-filled imitation pearls are smooth to the teeth in contrast to the gritty character of genuine nacre. A needle inserted into the drill hole at an angle will reveal the soft wax by feel. A pinpoint pushed against a wax-filled imitation will cause a momentary depression in the surface in contrast to natural pearl or any other substitute.

Solid Imitations. Solid glass imitations (so-called "indestructible pearl") are quite common in the trade. Their quality, like that of the wax-filled imitation, depends upon the number of applications of the "essence d'orient". Often as many as forty applications are made in the finer qualities. The detection of the solid glass imitation is similar to that of the wax-filled. It, too,

is smooth to the teeth. The edges of the drill hole are glassy. Under magnification, the surface appears smooth, rather than scaly as in genuine and cultured pearls. When held to the light, both genuine and cultured pearls show a translucent rim not visible in the imitation.

Pink Coral. Pink conch pearls are often imitated by the use of coral. They have a higher specific gravity than coral (conch pearl about 2.85, coral 2.70), and their surface appearance is different. Coral shows distinct irregular surface pits. Conch pearls often have a mottled appearance.

Conclusions. One of the most difficult tasks for the practicing gemologist is the distinction between genuine and cultured pearls. Unless the jeweler has a Pearloscope or X-ray equipment, he can do no more than make simple tests which will give him an indication, but not final proof, of the true nature of the pearl. The gemologist with limited equipment is more often forced to submit pearls to trade laboratories for identification than any other type of gem.

Chapter XIII

Instruments Essential to Gem Testing

Success in gem testing is dependent on two factors: (1) experience and skill in instrument use, and (2) adequacy of equipment. It is possible to make an occasional identification by eye alone, but only in exceptional circumstances such as the detection



Figure 107

Erb and Gray Refractometer on stand.

of a garnet-and-glass doublet by the large difference in luster between its two portions. For the vast majority of gem identifications made by the jeweler, several gem testing instruments are essential. The ideal laboratory would contain every instrument

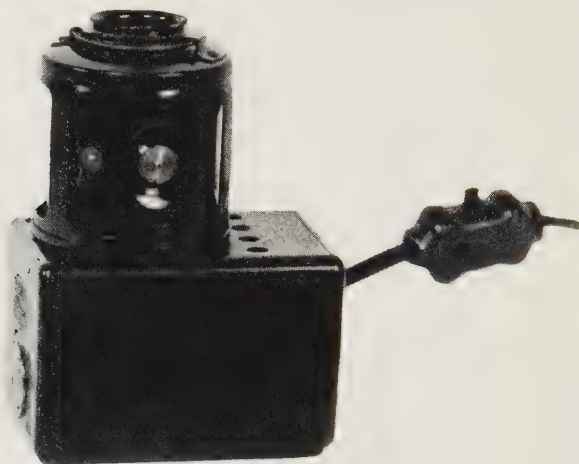

Figure 108

Polariscope mounted on a substage lamp.

that can aid in identification, no matter how seldom certain specialized equipment might be used. However, the expense of outfitting such a laboratory is prohibitive. In planning a gem testing laboratory, the average jeweler must weigh effectiveness against cost before deciding what instruments are essential for his purposes.

Three determinations are necessary in almost every identification: (1) refractive index, (2) single or double refraction, and (3) the shape of inclusions, (to decide between synthetic and natural origin). The instruments discussed below are those which are most practical for use in making the three essential determinations. Since a fourth determination, specific gravity, is often necessary, the most practical methods for that determination are also discussed.

Instruments Essential to Gem Testing

The Gem Refractometer. *Refractive index* is most easily determined by use of the gem refractometer. Refractometers range in price from \$89 to \$150¹. The refractometer also may be used to determine birefringence and, occasionally, optic character. Although the refractometer is by far the most practical method of determining refractive index, others may be substituted if the necessary equipment is available. Other methods were discussed in Chapter V.

Since the determination of refractive index is required in the large majority of identifications, the practical and relatively inexpensive refractometer is essential to the gemologist.

The Polariscope. The most practical instrument available for use in distinguishing between single and double refraction is the polariscope.² The polariscope is also used to detect pleochroism and optic character.

Although its accuracy is questionable, the reflection test (Chapter VI) is often used in distinguishing between single and double refraction.

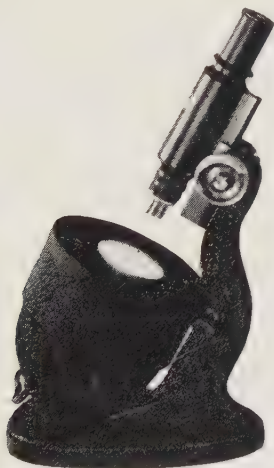

Figure 109

The Gemolite.

¹ Gemological Institute of America, Los Angeles.

² Gemological Institute of America, Los Angeles (\$25).

Magnifiers. Synthetic and natural gems are distinguished by examination of their inclusions under magnification. Magnifiers vary in price from the inexpensive loupe to the gemological microscope which may cost as much as \$1,000. Since the loupe seldom resolves inclusions with the clarity necessary to classify them, the gemologist requires a microscope for higher magnification. The Gemolite, especially designed for gem identification, provides magnification from ten to one hundred diameters.³ The Diamondscope and the Diamond Imperfection Detector are more elaborate instruments also designed for gem magnification. A variety of microscopes designed for other purposes may be adapted for gem identification by improvising the proper lighting for clear resolution of the interior of the faceted gem. Such microscopes range in price from \$125 to \$400.⁴

Specific Gravity Determination. A fourth test upon which the gemologist must often depend is the determination of specific gravity. The most practical of the many means of specific gravity determination is the use of the diamond balance with attachments that permit the weighing of the gem in a liquid. Since the diamond balance is standard equipment in the average jewelry store, and the attachments necessary for specific gravity determination are inexpensive or easily constructed, this method is the most practical for the jeweler. Liquids of high density are excellent for rapid determination. Their value is not limited by the fact that few satisfactory liquids are readily available, since it is possible to prepare liquids of intermediate value by mixing two such liquids in any proportion, providing the two are miscible in all proportions.

LESS FREQUENTLY USED GEM TESTING INSTRUMENTS.

The *dichroscope* is a small instrument used for the determination of pleochroism.⁵ The value of the dichroscope is limited since its use is confined to the determination of

³ Gemological Institute of America, Los Angeles (\$228).

⁴ American Optical Company, Buffalo, N. Y., Bausch & Lomb Optical Co., or Gemological Institute of America.

⁵ Gemological Institute of America (\$12.50).

Instruments Essential to Gem Testing

pleochroism. The presence of pleochroism is proof of double refraction, but its absence is NOT proof of single refraction—especially in the light colored stones.

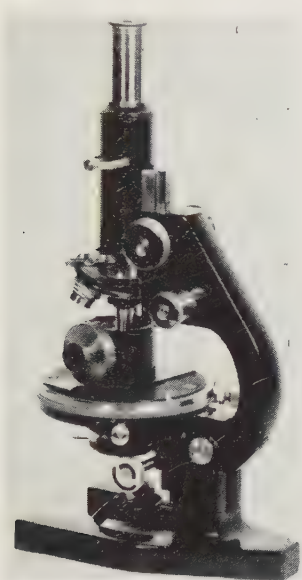

Figure 110

The Gemological Microscope with the Shipley Universal Motion Immersion Stage.

The Gemological Microscope.⁶ The polarizing gemological microscope is an expensive but very valuable instrument. With standard equipment, it provides magnifications from 10X to 600X. It is the most accurate means of distinguishing between single and double refraction and of detecting pleochroism. In addition, the gemological microscope, used in conjunction with a large set of liquids, permits the most accurate determination of refractive index. Optic character may also be determined by this instrument with greater facility than by any other method. Unfortunately, the high cost (\$600-\$1,000) of the gemological microscope and the skill its use requires, preclude its use in the average gemological laboratory.

Ultra-violet lamps. Ultra-violet radiation of certain wave lengths excites fluorescence in many materials. The nature of the fluorescence may be of value in identifying the gem which exhibits the property. The most effective wave lengths are 2500Å. and 3500Å. The Mineralight⁷ will provide 2500Å. radiation and the G. I. A. Fluorescent Unit⁸, 3500Å. Characteristic

6 American Optical Company, Buffalo, N. Y., Bausch & Lomb Optical Co., or Gemological Institute of America.

7 Available at any mineral supply house (\$35 — \$100).

8 Gemological Institute of America, Los Angeles (\$49.50).

fluorescence is the certain method of detection of synthetic emerald. By using a yellow filter on the Fluorescent Unit, a semimonochromatic light is obtained that is suitable for refractometer readings.

*Emerald Filter.*⁹ The emerald filter is used to distinguish between glass or assembled imitations and emerald. (For other uses, see Page 99). Although it is not often used in the large laboratory, the emerald filter proves valuable in the small gemological laboratory.

Spectroscope. Spectroscopes used in gem identification are of two types — prism and diffraction grating. An inexpensive but efficient English instrument, the Beck Hand Spectroscope, is probably the most practical for the gemological laboratory. Its principal use is the distinction between spinel and pyrope when their properties overlap. Since its applicability to gem testing is limited and its manipulation rather exacting, it has not been widely used in this country.

Hardness Points and Plates. Hardness points and plates, the traditional means of gem testing, are used by the present-day gemologist only as a last resort when all other tests fail to produce a positive identification. They are almost never needed in the testing of transparent gemstones, but become important to the gemologist in the identification of opaque gems. They are inexpensive and easily used, but careless handling may easily result in irreparable damage to a fragile gem. While scratches on the back of an opaque gem do not detract from its beauty, similar marks on the pavilion facets of a transparent gem may be visible from the crown. Since they are often necessary to the correct classification of opaque gemstones, hardness points or plates are essential to the gemological laboratory.

A Monochromatic Light Source. The increased clarity and sharpness of refractive index readings in sodium light makes the monochromatic sodium lamp an important instrument in the complete laboratory. The use of a monochromatic light source in conjunction with the refractometer enables the gemologist to de-

⁹ Gemological Institute of America, Los Angeles (\$3.50)

Instruments Essential to Gem Testing

termine birefringence and, occasionally, optic character, in addition to obtaining accurate index readings.

X-ray Equipment. X-radiographic and X-ray diffraction equipment is used in large laboratories for the identification of pearls. Diffraction equipment is now used successfully for the identification of gemstones without harming the gem in any manner. The new method is the result of research by George Switzer, Ph.D., and Ralph J. Holmes, Ph.D., in the laboratories of the Gemological Institute of America. The cost of X-ray equipment is prohibitive and skilled technicians are needed to use it successfully; hence, it is not suitable for the gem testing laboratory of the individual jeweler.

Chapter XIV

A Procedure for the Identification of Gemstones and Their Substitutes

The jeweler, when called upon to identify an unknown gem, can guess at its identity or he can make a positive identification based on a few simple tests. The advantages of the latter method are many. The identifications can be positive, quickly made, and they do not require elaborate equipment. The jeweler who guesses at the identity of gemstones will undoubtedly be correct on some occasions, but too often errors are made by even the most experienced observer. To avoid such errors it is necessary to rely on the determinations made by gem testing instruments.

Errors are reduced to a minimum by following an *eliminative* method of testing. A list of all gems which occur in the color of the gem being tested should be made. As each determination is made, names are eliminated from the list until only the correct name for the gem being tested remains. If the tests are carefully performed, an eliminative method will prevent errors.

The procedure followed in the identification chapters of this handbook is outlined below.

- 1) Clean the unknown gem and examine it by unaided eye or through a low power loupe to observe color, general appearance, degree of transparency and strength of dispersion. Make a list of the possible gemstones and substitutes that occur in the color and degree of transparency of the unknown. Such lists are at the beginning of each identification chapter of this handbook.

Identification of Gemstones

- 2) Examine the stone under high magnification (30X to 60X or higher, if necessary) to determine the shape of inclusions or growth lines to decide whether the gemstone is natural or artificial.
- 3) Immerse the gem in a liquid of intermediate to high refractive index to detect doublets or triplets, or to re-examine it if no inclusions were discovered in the second test.
- 4) Examine the gem in a polariscope or under a gemological microscope to test it for single or double refraction. The pleochroism (if any) of the gemstone is also determined at this point, either with the instruments named, or with the dichroscope.
- 5) The refractometer is used to determine the refractive index or indices of the gem. Most transparent gems not already classified are identified at this point in the procedure.
- 6) The specific gravity of the unknown is determined on a modified diamond balance, or by means of heavy liquids.
- 7) If there is no alternative, the hardness of the gem is tested.

First Test. The initial examination is important since any unusual property of the unknown gemstone may provide an immediate identification, or a valuable clue to its identity. Doublets, triplets and foil backs are often identified on close inspection by an experienced observer who notes a luster or color differences between portions. Often glass can be detected by a molded appearance on pavilion facets. Strong dispersion, doubling of back facet edges, adamantine luster, and other unusual features or properties that affect the appearance of gemstones all assist in the identification. For example, if a gem displays strong doubling of the pavilion facet edges when examined through the table, there are only two or three gems of any given color that it could be. The gems on the elimination list that are

not strongly doubly refractive could be eliminated at once if such an appearance is observed in the initial examination. The presence of any unusual appearance will remove from the list of possibilities any gem which never presents such an appearance.

Second Test. The examination of the interior of the gem under magnification of 30X to 60X usually discloses inclusions or imperfections characteristic of either natural or artificial origin. Thus most gem substitutes are either detected or eliminated from the list of possibilities by this test. The fact that the gem he seeks to identify is not genuine is often all the jeweler wants to determine, in which event, no further tests are made. If the gem has spherical bubbles, curved striae or color zones, and double images of the back facet edges are evident, the only possibility is synthetic corundum (synthetic ruby and synthetic sapphire), since it is the only doubly refractive material with such inclusions.

It is often possible to determine more from natural inclusions than the fact of the genuine character of the gem, since several gem species have inclusions that are unlike those of any other gem. The presence of such characteristic inclusions in certain species permits positive identification without further tests. The observation of double images of back facet edges obviates the necessity for the polariscope test for double refraction.

Third Test. The third test in the recommended procedure for gem identification is immersion in a liquid of intermediate or high refractive index. Doublets and triplets are easily detected when facet reflections are effectively reduced, as they are by immersion in such a liquid. Immersion also facilitates resolution of inclusions in stones in which such objects were not revealed when first examined under magnification. If the unknown gem has not been identified at this stage, it is either a substitute or a natural gemstone. In addition, inclusions or unusual appearance may have provided clues to its identity.

Identification of Gemstones

Fourth Test. The next step in the identification of an unknown gemstone is the determination of its singly or doubly refractive character, using a polariscope or the polarizing microscope. Double refraction can also be determined on the refractometer, under magnification, or by the reflection test. The determinations that have been made thus far have eliminated many names from the original list. The observer can be certain that the unknown gem is in one of the four groups determined by the findings of the second and fourth tests. The other three groups have been eliminated. It has been determined to be either singly or doubly refractive, and either natural or artificial. If the stone proves to be natural and doubly refractive, it is next examined through the dichroscope or polariscope to determine its pleochroism. Many doubly refractive gems have characteristic pleochroic colors when they occur in certain hues. Such characteristic pleochroism permits positive identification.

Fifth Test. The fifth test is the determination of refractive index on a refractometer, or by other methods described in Chapter V. In almost all cases, the gem will be identified by this test. The refractometer can be used to determine the strength of double refraction (birefringence), and sometimes optic character can be ascertained, if a monochromatic light source is available.

Sixth Test. In rare cases, it is necessary to determine the specific gravity of a transparent gem to be certain of its identity. The determination of specific gravity is usually an important factor in the identification of nontransparent gems. The test is made on a diamond balance equipped with a few simple attachments, or with heavy liquids.

Seventh Test. Hardness tests should be made on transparent gems only as a last resort.

Modification of Testing Procedure for Nontransparent Gems. If the unknown gem is translucent, the procedure described above is not changed. If, however, no light is transmitted by the gem, the observer should proceed to the determination of specific gravity after the initial examination. The specific gravity and hardness tests assume an added importance in the identification of opaque gemstones, since so few tests are applicable.

Identification Sections

The following ten sections are devoted to the identification of groups of gemstones segregated by color and transparency. Each chapter relating to transparent gemstones and their substitutes follows the identification procedure outlined in Chapter XIV.

When called upon to identify an unknown gemstone, turn to the chapter referring to gems of the same color and transparency as the one you are examining. Usually positive identification can be established before all tests have been made. In this event, of course, the remaining tests are not necessary.

Each chapter on the identification of transparent gems is followed by a flow-chart condensation of results which should be obtained from each test in the procedure. The last three sections are devoted to the identification of nontransparent gemstones and their substitutes.

To hasten familiarization with a uniform method of identification that reduces to a minimum the chance of error, the procedure outlined in Chapter XIV is followed in each succeeding identification chapter with only the minor deviations peculiar to the identification of that group. The necessary repetition is more than justified by the resultant development of quick and accurate testing habits.

Chapter XV

The Identification of Transparent Purple and Violet Gemstones and Their Substitutes

Transparent gems and their substitutes that are found in a purple or violet color include the following:

Almandite garnet	Rhodolite garnet
Beryl (morganite)	Spinel
Chrysoberyl (alexandrite)	Spodumene (kunzite)
Corundum (sapphire)	Synthetic corundum
Diamond	Synthetic spinel
Glass	Topaz
Plastics	Tourmaline
Pyrope garnet	Zircon
Quartz (amethyst)	Doublets

Gems infrequently encountered in the jewelry trade:

Andalusite

Fluorite

Descriptions of Transparent Purple and Violet Gemstones and Their Substitutes. ALMANDITE GARNET, while normally dark violetish-red to brownish-red, is often dark purple to reddish-purple. BERYL (MORGANITE) is often very light purple. CHRYSOBERYL (ALEXANDRITE) that becomes dark purple rather than dark violet-red under artificial light is but rarely found. Corundum (sapphire) occurs in very light to dark tones of both purple and violet. While such gems resemble amethyst in color, their brilliancy distinguishes them from amethyst. DIAMOND of a purple or violet hue is very rare. GLASS is made that resembles amethyst very closely. PLASTICS are also made

Identification of Transparent Purple, Violet Gemstones

to resemble amethyst. PYROPE GARNET is found occasionally in dark tones of reddish-purple. QUARTZ (AMETHYST), one of the commonest of gems, occurs in very light to dark tones of purple to violet. RHODOLITE GARNET occurs in medium tones of violetish-red to purple. SPINEL in medium to very dark tones of purple to violet is fairly common. It resembles amethyst, but appears more brilliant. SPODUMENE (KUNZITE) is often found in light to very light tones of purple to violet. SYNTHETIC CORUNDUM and SYNTHETIC SPINEL are often made to resemble amethyst. TOPAZ is sometimes light to very light purple. TOURMALINE occurs in very light to medium tones of violet to red-violet. ZIRCON of a dark purple-brown hue is occasionally used as a gem. DOUBLETS of garnet and glass are about the only assembled stones made to imitate amethyst.

Gems infrequently encountered in the jewelry trade.

ANDALUSITE showing a color change from greenish-brown in daylight to purplish-brown in artificial light is sometimes used as a gem. FLUORITE of a purple to violet hue is common in nature, but is rarely cut as a gem. In these hues it resembles a poorly polished amethyst.

Testing Procedure. It should be emphasized that it is not necessary to make all the tests indicated in identifying every stone. However, unless a gem is determined to be a doublet, or shows inclusions characteristic of a synthetic, a determination is rarely positive until tests have been carried through the refractive index reading.

First Test. Clean the stone and examine it with the unaided eye or low power loupe for any unusual property or appearance. In this preliminary examination, observation of any of the following properties may facilitate identification:

Strong dispersion suggests diamond; possibly zircon.

Double images of back facet edges are often visible in a large zircon without aid of magnification.

Molded back facets prove the unknown to be a glass or plastic imitation. (See Chapter XI).

A luster difference between crown and pavilion or between table and the lower crown facets suggests a doublet.

Unusually dull luster suggests fluorite.

Distinct color change from daylight to artificial light indicates andalusite, chrysoberyl (alexandrite) or synthetic alexandrite-like sapphire.

Warmth to the touch (compared to the cold feel of crystalline materials) is a property of amorphous materials such as glass and plastic imitations.

Adamantine luster suggests diamond.

A visible separation plane indicates a doublet.

Second Test. Examine the gem under magnification (30X to 60X or higher, if necessary).^{*} The magnification test often does more than distinguish between natural and man-made gems, since it makes possible the observation of the inclusions which often characterize a single natural gem species.

Characteristic inclusions of natural and synthetic gemstones are described and illustrated in Chapter VIII. Angular inclusions characterize natural gems; spherical bubbles, or curved striae, prove artificial origin.

Magnification often reveals double images of pavilion facet edges or of inclusions. In this event, the polariscope test is eliminated, hastening the final identification. If double images accompany the spherical bubbles that prove artificial origin, the unknown must be synthetic corundum, since synthetic corundum is the only man-made doubly refractive purple and violet gem.

Inclusions characteristic of a single gem species also identify an unknown at this point.

^{*}If not available, use a 10X or 20X loupe.

Identification of Transparent Purple, Violet Gemstones

ANGULAR INCLUSIONS REVEALED UNDER HIGH MAGNIFICATION INDICATE THE FOLLOWING NATURAL, TRANSPARENT, PURPLE OR VIOLET GEMSTONES:

Almandite garnet	Rhodolite garnet
Beryl (morganite)	Spinel
Chrysoberyl (alexandrite)	Spodumene (kunzite)
Corundum (sapphire)	Topaz
Diamond	Tourmaline
Pyrope garnet	Zircon
Quartz (amethyst)	Doublets

Gems infrequently encountered in the jewelry trade:

Andalusite	Fluorite
------------	----------

TRANSPARENT PURPLE AND VIOLET MATERIALS CONTAINING INCLUSIONS CHARACTERISTIC OF ARTIFICIAL ORIGIN:

Glass	
Plastics	Doublets partially composed of
Synthetic corundum	glass or wholly genuine materials
Synthetic spinel	with bubbles in the joining plane.

Third Test. Immerse the gem in a liquid of intermediate to high refractive index to detect a doublet, or to re-examine it if no inclusions were discovered in the second test. (See Chapter VII). The presence of a separation plane across the gem may now identify it as a doublet, in which case no test, other than one to determine the nature of the portions of the assembled stone, need be made. Thus, doublets are either detected or eliminated by this test.

If it is difficult to resolve the gem's inclusions with an ordinary microscope, it may be because the gem is of high refractive index, therefore highly reflective, especially if the gem is brilliant-cut. In this event, or if no inclusions were visible on first examination under high magnification, immerse the gem in bromoform or methylene iodide to reduce reflections and improve the view of its interior. Re-examine it very carefully, but bear in mind that some gems are without identifying flaws under *any* feasible magnification.

Fourth Test. Examine the gem in the polariscope or under a polarizing microscope, to test it for single or double refraction. Double refraction may also be detected under magnification, on the refractometer, with the dichroscope or by the reflection test. Since it is not always apparent using the latter methods, failure to discover double refraction by methods other than those involving the polariscope or polarizing microscope is NOT proof of single refraction. Directions for use of the instruments for detection of single and double refraction are given in Chapter VI. (For table of optic character, see Appendix).

On the basis of one or more of the tests for single and double refraction and the previous tests, the gem can be assigned to one of the following groups:

1. DOUBLY REFRACTIVE, TRANSPARENT, NATURAL PURPLE OR VIOLET GEMS:

Andalusite*	Quartz (amethyst)
Beryl (morganite)	Spodumene (kunzite)
Chrysoberyl (alexandrite)	Topaz
Corundum (sapphire)	Tourmaline
	Zircon

2. SINGLY REFRACTIVE, TRANSPARENT, NATURAL PURPLE OR VIOLET GEMS:

Almandite garnet	Pyrope garnet
Diamond	Rhodolite garnet
Fluorite*	Spinel

3. DOUBLY REFRACTIVE, TRANSPARENT, ARTIFICIAL, PURPLE OR VIOLET GEM MATERIAL:

Synthetic Corundum

4. SINGLY REFRACTIVE, TRANSPARENT, ARTIFICIAL, PURPLE OR VIOLET GEM MATERIALS:

Glass	Synthetic Spinel
Plastics	

*Gems infrequently encountered in the jewelry trade.

Identification of Transparent Purple, Violet Gemstones

Synthetic spinel almost invariably exhibits strong anomalous double refraction. The effect observed is a "cross-hatched" appearance in the dark (crossed Nicols) position of the polariscope or polarizing microscope (See Figure 84).

If the gem proves to be doubly refractive, test it for pleochroism, using the dichroscope, polariscope or polarizing microscope. The following gems often display STRONG DICHROISM. Their characteristic dichroic colors follow:

Violet and orange — sapphire.

Purple and light purple — tourmaline.

Brown and red-purple — andalusite.

WEAK DICHROISM is of little value in the identification of purple stones, since most of the pale gems exhibit little or no color difference.

The only purple or violet gem which shows STRONG TRICHROISM is the *alexandrite variety of chrysoberyl*. Its trichroic colors are *dark red-purple, orange and dark green*.

The pleochroic colors of the remaining doubly refractive purple or violet stones are too weak to be of assistance.

Now it has been established that the gem occurs in one of the four groups listed under the fourth test. In addition, characteristic inclusions, dichroism and luster may have proved useful as clues to the identity of the unknown gem. Usually the determination of refractive index will positively identify the gem at this point in the procedure.

Fifth Test. Examine the stone on a refractometer to determine the refractive index. Unless the refractometer reading is a value midway between the figures given for two gems in the tables that follow, a careful reading will leave no doubt as to the gem's identity. If no reading is obtained, or if the reading is inconclusive, an approximate index may be determined in some cases by means of the apparent depth method, or the approximate immersion method. If no index value is obtained, proceed to the next test.

HANDBOOK OF GEM IDENTIFICATION

PRINCIPAL INDICES OF NATURAL, DOUBLY REFRACTIVE, TRANSPARENT, PURPLE OR VIOLET GEMSTONES:

Zircon (high, medium).....	1.925	to 1.984
Corundum (sapphire).....	1.762 (— .003, + .008)	to 1.770 (— .003, + .008)
Chrysoberyl (alexandrite).....	1.746 (± .004)	to 1.755 (± .005)
Spodumene (kunzite).....	1.660 (± .005)	to 1.676 (± .005)
Andalusite*	1.634	to 1.643
Tourmaline	1.624 (± .005)	to 1.644 (± .006)
Topaz	1.619 (± .012)	to 1.627 (± .012)
Beryl (morganite)	1.585 (± .004)	to 1.593 (± .004)
Quartz	1.544 (± .00)	to 1.553 (± .00)

If difficulty is encountered in distinguishing corundum from chrysoberyl by means of the difference in their refractive index readings, a specific gravity determination will separate the two gemstones. Tourmaline is easily distinguished from andalusite and topaz by its strong birefringence. A specific gravity test will separate andalusite and topaz.

INDICES OF NATURAL, SINGLY REFRACTIVE, TRANSPARENT, PURPLE OR VIOLET GEMSTONES:

Diamond	2.417
Almandite garnet	1.79 (± .02)
Rhodolite garnet	1.76 (± .02)
Pyrope garnet	1.746 (— .016 to + .010)
Spinel	1.726 (± .014)
Fluorite*	1.434 (± .00)

INDICES OF ARTIFICIAL, DOUBLY REFRACTIVE, TRANSPARENT, PURPLE OR VIOLET GEM MATERIAL:

Synthetic corundum	1.76 to 1.77
--------------------------	--------------

INDICES OF ARTIFICIAL, SINGLY REFRACTIVE, TRANSPARENT, PURPLE OR VIOLET GEM MATERIALS:

Glass (extreme range of gem imitation types).....	1.44-1.77
Glass (normal range)	1.48-1.70
Synthetic spinel.....	1.73 (± .010)
Plastics—Celluloid	1.49-1.52
Plexiglass and lucite.....	1.50
Bakelites	1.55-1.67
Polystyrene	1.59-1.67

(Maximum range for plastics 1.49-1.67)

*Gems infrequently encountered in the jewelry trade.

Identification of Transparent Purple, Violet Gemstones

Sixth Test. Test the gem for specific gravity on the diamond balance, or with high-density liquids. It is rarely necessary to determine specific gravity, since the gem should have been identified by the time the refractive index reading has been made.

SPECIFIC GRAVITY OF NATURAL, DOUBLY REFRACTIVE, TRANSPARENT, PURPLE OR VIOLET GEMSTONES:

Zircon (high, medium).....	4.70 ($\pm .03$)
Corundum (sapphire).....	4.00 ($\pm .05$)
Chrysoberyl (alexandrite).....	3.73 ($\pm .02$)
Topaz	3.53 ($\pm .04$)
Spodumene (kunzite)	3.18 ($\pm .03$)
Andalusite*	3.17 ($\pm .04$)
Tourmaline	3.04 ($\pm .05$)
Beryl (morganite)	2.82 ($\pm .05$)
Quartz	2.66 ($\pm .01$)

Methylene iodide (3.32) is very effective in the separation of tourmaline and andalusite from topaz, since topaz sinks while the others float. in the liquid. Spodumene and andalusite are distinguished by their dichroism or refractive indices.

SPECIFIC GRAVITY OF NATURAL, SINGLY REFRACTIVE, TRANSPARENT, PURPLE AND VIOLET GEMSTONES:

Almandite garnet.....	4.05 ($\pm .12$)
Rhodolite garnet.....	3.84 ($\pm .12$)
Pyrope garnet.....	3.78 ($\pm .09$)
Spinel	3.60 ($-.03, +.30$)
Diamond	3.52 ($\pm .01$)
Fluorite*	3.18 ($\pm .01$)

The specific gravity range in this group is sufficiently great so that a careful determination will give the correct identification, and eliminate the necessity for further tests.

SPECIFIC GRAVITY OF ARTIFICIAL, DOUBLY REFRACTIVE, TRANSPARENT, PURPLE AND VIOLET GEM MATERIAL:

Synthetic corundum.....	4.00 ($\pm .03$)
-------------------------	--------------------

**Gems infrequently encountered in the jewelry trade.*

Since synthetic corundum is the only truly double refractive substitute for a natural purple or violet gem, determination of double refraction and characteristic inclusions visible under magnification would have eliminated it before this stage in the identification had been reached.

SPECIFIC GRAVITY OF ARTIFICIAL, SINGLY REFRACTIVE, TRANSPARENT, PURPLE AND VIOLET GEM MATERIALS:

Glass	2.3 to 4.5
Synthetic spinel.....	3.60 ($\pm .15$)
Plastics less than 2.0— with rare exceptions they float in carbona (density 1.59).	

The specific gravity of glass can be the same as that of synthetic spinel, in which case the typical “cross-hatched” appearance due to anomalous double refraction in synthetic spinel will distinguish it (see illustration on page 113). Since neither is valuable, the hardness test can be used. Glass is easily scratched by a steel file, but synthetic spinel is not.

Seventh Test. Hardness should be used in the identification of transparent gems only as a last resort. If the gemologist has the necessary instruments to make a positive identification by the foregoing procedure, a hardness determination should never be made. (See hardness table, page 9).

Identification of Transparent Purple, Violet Gemstones

Transparent Gems and Their Substitutes that Occur in a PURPLE or VIOLET color.				
First Test Initial Examination	Almandite *Andalusite Beryl Chrysoberyl Corundum Diamond	*Fluorite Glass Plastics Pyrope Quartz Rhodolite	Spinel Spodumene Synthetic Corundum Synthetic Spinel	Topaz Tourmaline Zircon Doublets
	Natural Gems			Man-Made
Second Test Magnification to Determine Shape of Inclusions, Etc.	Almandite *Andalusite Beryl Chrysoberyl Corundum Diamond	*Fluorite Pyrope Quartz Rhodolite Topaz Tourmaline	*Spodumene Spinel Zircon Doublets	Glass Plastics Synthetic Corundum Synthetic spinel Doublets
Third Test Immersion	Doublets or Triplets detected or eliminated.			
	Natural Singly Refractive	Natural Doubly Refractive	Artificial Singly Refractive	Artificial Doubly Refractive
Fourth Test Single or Double Refraction. Pleochroism	Almandite Diamond *Fluorite Pyrope Rhodolite Spinel	*Andalusite Beryl Chrysoberyl Corundum Quartz Spodumene Topaz Tourmaline Zircon	Glass, extreme Glass, normal Synthetic Spinel Plastics Celluloid Plexiglass and Lucite Bakelites Polystyrene	Synthetic Corundum
Fifth Test Determination of Refractive Index	Diamond 2.417 Almandite 1.79 Rhodolite 1.76 Pyrope 1.746 Spinel 1.726 *Fluorite 1.434	Zircon 1.925-1.984 Corundum 1.762-1.770 Chrysoberyl 1.746-1.755 Spodumene 1.660-1.676 Tourmaline 1.624-1.644 Topaz 1.619-1.627 *Andalusite 1.634-1.643 Beryl 1.585-1.593 Quartz 1.544-1.553	Glass extreme 1.44-1.77 Glass, normal 1.48-1.70 Synthetic Spinel 1.73 Plastics Celluloid 1.49-1.42 Plexiglass & Lucite 1.50 Bakelites 1.55-1.67 Polystyrene 1.59-1.67 Maximum range for plastics 1.49-1.67	Synthetic Corundum 1.762-1.770
Sixth Test Determination of Specific Gravity	Almandite 4.05 Rhodolite 3.84 Pyrope 3.78 Spinel 3.60 Diamond 3.52 *Fluorite 3.18	Zircon 4.70 Corundum 4.00 Chrysoberyl 3.73 Topaz 3.53 Spodumene 3.18 *Andalusite 3.17 Tourmaline 3.04 Beryl 2.82 Quartz 2.66	Glass 2.3 to 4.5 Synthetic spinel 3.60 Plastics less than 2.0 with rare exceptions they float in carb. na, density 1.59	Synthetic Corundum 4.00
Seventh Test Hardness	Do not use unless it is essential.			

*Gems infrequently encountered in the jewelry trade.

Chapter XVI

The Identification of Transparent Blue Gemstones and Their Substitutes

The important transparent gemstones and their substitutes which occur in a blue color are:

Beryl (aquamarine)	Synthetic corundum
Corundum (sapphire)	Synthetic spinel
Diamond	Topaz
Glass	Tourmaline
Plastics	Zircon
Quartz (dyed)	Doublets
Chalcedony (dyed and natural)	Triplets
Opal	Foil backs
Spinel	

Gems infrequently encountered in the jewelry trade:

Apatite	Labradorite feldspar
Benitoite	Fluorite
Euclase	Iolite

Descriptions of Transparent Blue Gemstones and Their Substitutes. BERYL (AQUAMARINE) occurs in light to very light tones of blue to greenish-blue. CORUNDUM (SAPPHIRE) is not uncommon in every tone of blue, from very light to very dark. DIAMOND with a blue hue is exceedingly rare, but light blue stones appear in the trade. Their adamantine luster, brilliancy and dispersion (fire) set them apart. GLASS is manufactured in almost any color found in natural gems. Glass imitations usually have too little dispersion when imitating zircon, but too much when imitating beryl (aquamarine) and corundum (sapphire). PLASTICS are frequently molded to faceted shapes for use in costume jewelry. QUARTZ of a dark blue hue

Identification of Transparent Blue Gemstones

used in jewelry owes its color to dye adhering to a roughened back surface. CHALCEDONIC QUARTZ may take a light blue color from included chrysocolla or other minerals. Chalcedony is also dyed blue. OPAL is included as a blue gem because of the prominence of a blue play of color in black opal. SPINEL often resembles corundum (sapphire), although the former is usually less intense in color. SYNTHETIC CORUNDUM is made in a wide range of colors nearly matching the natural material. Blue SYNTHETIC SPINEL is made in light, medium and dark tones. The medium and dark tones of synthetic blue spinel are characterized by flashes of red as the stone is turned. TOPAZ is found in light to very light blue colors that are very similar to those of beryl (aquamarine). TOURMALINE occurs in a wide range of blue colors from light to very dark in tone. ZIRCON occurs in light to medium blue. Its brilliance and dispersion distinguish blue zircon from other gems and substitutes. DOUBLETS are made to imitate both sapphire and aquamarine. TRIPLETS of a blue hue are no longer manufactured and are rarely encountered. FOIL BACKS, blue in color, are usually star quartz backed with a blue mirror to lend color and enhance the star. The mirror is covered by a cement coating.

Gems infrequently encountered in the jewelry trade.

APATITE is found in light to medium tones of blue, usually resembling aquamarine, but sometimes having a color similar to sapphire. BENITOITE is uncommon because of its rarity in nature. In fine quality, it is difficult to distinguish from sapphire. EUCLASE is an exceedingly rare mineral sometimes used as a gem. It occurs in light to very light tones of blue. LABRADORITE FELDSPAR appears occasionally in the trade, usually carved or en cabochon. The gemstone is usually gray, with a blue or green iridescence. FLUORITE is a common mineral rarely cut as a gem, because it is soft and fragile. IOLITE (also known as cordierite and dichroite) in light to dark tones of blue is sometimes cut as a gem. It is remarkably pleochroic.

Testing Procedure. It should be emphasized that it is not necessary to make all the tests indicated in identifying every stone. However, unless a gem is determined to be a doublet, triplet or foil back, or shows inclusions characteristic of a synthetic, a determination is rarely positive until tests have been carried through the determination of refractive index.

First Test. Clean the stone and examine it with the unaided eye or a low power loupe for any unusual property or appearance. In this preliminary examination, observation of any of the following properties may facilitate identification:

Strong dispersion suggests diamond or zircon.

Dull luster suggests fluorite.

Adamantine luster suggests diamond.

Doubling of back facets is often visible to the unaided eye in a large zircon.

A visible separation plane indicates a doublet or triplet.

A molded appearance on back facets proves the unknown to be a glass or plastic imitation. (See Chapter XI.)

A coated back on a star stone proves a star quartz foil back.

An exceedingly low specific gravity is often noticeable in plastic imitations, when a large stone is lifted.

Warmth to the touch (compared to the cold feel of crystalline materials) is a property of amorphous materials such as glass and plastic imitations.

A luster difference between crown and pavilion or between table and the lower crown facets suggests a doublet.

Flashes of red from a dark sapphire-blue gem suggests synthetic spinel.

A six-rayed star in reflected light indicates star sapphire or a star quartz foil back.

Second Test. Examine the gem under high magnification (30X to 60X or higher, if necessary).* The magnification test often does more than distinguish between natural and man-made

*If not available, use a 10X or 20X loupe.

Identification of Transparent Blue Gemstones

gems, since it makes possible the observation of the inclusions which often characterize a single natural gem species.

Characteristic inclusions of natural and synthetic blue gemstones are described and illustrated in Chapter VIII. Angular inclusions characterize blue gems of natural origin; spherical bubbles or curved striae prove artificial origin.

Magnification often reveals double images of pavilion facet edges or of inclusions. In this event, the polariscope test is eliminated, hastening the final identification. If double images accompany the spherical bubbles that prove artificial origin, the unknown must be synthetic corundum, since synthetic corundum is the only man-made doubly refractive blue gem.

Inclusions characteristic of a single gem species also identify an unknown at this point.

ANGULAR INCLUSIONS REVEALED UNDER HIGH MAGNIFICATION INDICATES THE FOLLOWING NATURAL, TRANSPARENT, BLUE GEMSTONES:

Beryl (aquamarine)	Topaz
Corundum (sapphire)	Tourmaline
Diamond	Zircon
Opal	Doublets, triplets and foil backs
Quartz (dyed)	partially or wholly composed
Chalcedony (dyed or natural)	of natural materials.
Spinel	

Gems infrequently encountered in the jewelry trade:

Apatite	Fluorite
Benitoite	Iolite
Eucrase	Labradorite feldspar

TRANSPARENT BLUE GEMS CONTAINING INCLUSIONS CHARACTERISTIC OF ARTIFICIAL MATERIALS:

Glass	Doublets or triplets partially
Plastics	composed of glass or wholly
Synthetic corundum	genuine materials with bubbles
Synthetic spinel	in the joining plane.

Third Test. Immerse the gem in a liquid of intermediate to high refractive index to detect a doublet or triplet, or to re-examine it if no inclusions were discovered in the second test.

(See Chapter VII.) If it is difficult to resolve the gem's inclusions with an ordinary microscope, it may be because the gem is of a high refractive index, therefore, highly reflective, especially if the gem is brilliant-cut. In this event, or if no inclusions were visible on first examination under high magnification, immerse the gem in bromoform or methylene iodide to reduce reflection and improve the view of its interior. Re-examine it very carefully, but bear in mind that some gems are without identifying flaws under *any* feasible magnification.

The presence of a separation plane across the gem may now identify it as a doublet or triplet, in which case no test, other than one to determine the nature of the portions of the assembled stone, need be made. Thus, doublets and triplets are either detected or eliminated by this test.

Fourth Test. Examine the gem in the polariscope or under a polarizing microscope, to test it for single or double refraction. Double refraction may also be detected under magnification, on the refractometer, with the dichroscope, or by the reflection test. Since it is not always apparent using the latter methods, failure to discover double refraction by methods other than those involving the polariscope or polarizing microscope is NOT proof of single refraction. Directions for use of the instruments for detection of single and double refraction are given in Chapter VI.

An interference figure might be obtained during this examination, providing an important clue to the identity of the gem. (For optic character table, see Appendix.)

On the basis of one or more of the tests for single and double refraction and the previous tests, the gem can be assigned to one of the following groups:

1. DOUBLY REFRACTIVE, TRANSPARENT, NATURAL BLUE GEMS:

Beryl (aquamarine)	Topaz
Corundum (sapphire)	Tourmaline
Quartz (dyed)	Zircon
Chalcedony (dyed or natural)	

Identification of Transparent Blue Gemstones

Gems infrequently encountered in the jewelry trade:

Apatite	Iolite
Benitoite	Labradorite feldspar
Euclase	

2. SINGLY REFRACTIVE, TRANSPARENT, NATURAL BLUE GEMS:

Diamond	Opal
Fluorite*	Spinel

3. DOUBLY REFRACTIVE, TRANSPARENT, ARTIFICIAL BLUE GEM MATERIAL:

Synthetic corundum

Synthetic corundum is easily determined at this point since it is the only one of the four artificial gemstones in this color range which shows true double refraction and dichroism.

4. SINGLY REFRACTIVE, TRANSPARENT, ARTIFICIAL BLUE GEM MATERIALS:

Glass	Synthetic spinel
Plastics	

The characteristic "cross-hatched" appearance caused by strong anomalous double refraction distinguishes synthetic spinel.

If the gem proves to be doubly refractive, test it for pleochroism, using the dichroscope, polariscope or polarizing microscope. The following gems often display the following characteristic dichroic colors:

DICHROISM, STRONG

Dark violetish-blue and light blue-green—corundum (sapphire), synthetic and natural.

Blue and yellow—apatite.

Medium blue, and grayish-yellow to colorless—zircon.

One image colorless; the other dark blue—benitoite.

**Gem infrequently encountered in the jewelry trade.*

DICHHROISM, WEAK TO DISTINCT

Light blue and dark blue—beryl (aquamarine).

One image light blue; the other colorless—topaz.

The dichroism of euclase, and dyed quartz is exceedingly weak.

TRICHHROISM, VERY STRONG

Colorless to yellow, blue-gray, and dark blue-violet — iolite.

Now it has been established that the gem occurs in one of the four groups listed under the fourth test. In addition, characteristic inclusions, dichroism, optic character and luster may have proved useful as clues to the identity of the unknown gem. Usually the determination of refractive index will positively identify the gem at this point in the procedure.

Fifth Test. Place the stone on a refractometer to determine the refractive index. If the gem is doubly refractive, it is often possible to determine optic character. Unless the refractometer reading is a value midway between the figures given for two gems in the tables that follow, a careful reading will leave no doubt as to the gem's identity. If no reading is obtained, or if the reading is inconclusive, an approximate index can be determined in some cases by means of the apparent depth method, or the approximate immersion method. If no index value is obtained, proceed to the next test.

INDICES OF NATURAL, DOUBLY REFRACTIVE, TRANSPARENT BLUE GEMSTONES:

Zircon (high, medium).....	1.925	to 1.984
Corundum (sapphire).....	1.762 (— .003, + .008)	to 1.770 (— .003, + .008)
Benitoite *	1.757	to 1.804
Euclase*	1.651	to 1.670
Apatite *	1.642	to 1.646
Tourmaline	1.624 (± .005)	to 1.644 (± .006)
Topaz	1.619 (± .012)	to 1.627 (± .012)
Beryl (aquamarine).....	1.577 (± .016)	to 1.583 (± .017)
Labradorite feldspar	1.559	to 1.566
Quartz (dyed).....	1.544 (± .00)	to 1.553 (± .00)
Calcedony		
(dyed and natural)....	1.535	to 1.539
Iolite*	1.542	to 1.551

*Gems infrequently encountered in the jewelry trade.

Identification of Transparent Blue Gemstones

If difficulty is encountered in distinguishing corundum from benitoite by means of the difference in their refractive index readings, a specific gravity determination will separate the two gemstones. Tourmaline is easily distinguished from topaz by its strong birefringence or by a specific gravity test. Quartz and iolite are easily separated by a test for pleochroism, or by the determination of optic character.

INDICES OF NATURAL, SINGLY REFRACTIVE, TRANSPARENT, BLUE GEMSTONES:

Diamond	2.417
Spinel	1.726 ($\pm .014$)
Opal	1.45
Fluorite*	1.434 ($\pm .00$)

The only artificial, doubly refractive, transparent, blue gemstone not previously identified, synthetic corundum, was probably eliminated or identified in test four; however, the indices of this material are listed below.

INDICES OF ARTIFICIAL, DOUBLY REFRACTIVE, TRANSPARENT, BLUE GEM MATERIAL:

Synthetic corundum	1.762 ($\pm .002$) to 1.770 ($\pm .002$)
--------------------------	----------------------------------------------

INDICES OF ARTIFICIAL, SINGLY REFRACTIVE, TRANSPARENT, BLUE GEM MATERIALS:

Glass (extreme range of gem imitation types).....	1.44-1.77
Glass (normal range).....	1.48-1.70
Synthetic spinel.....	1.73 ($\pm .01$)
Plastics—celluloid	1.49-1.52
plexiglass and lucite.....	1.50
bakelites	1.55-1.67
polystyrene	1.59-1.67

(Maximum range for plastics 1.49-1.67)

Sixth Test. Test the gem for specific gravity on the diamond balance, or with high density liquids. It is rarely necessary to determine specific gravity, since the gem should have been identified by the time the refractive index reading has been made.

**Gems infrequently encountered in the jewelry trade.*

HANDBOOK OF GEM IDENTIFICATION

SPECIFIC GRAVITY OF NATURAL, DOUBLY REFRACTIVE, TRANSPARENT, BLUE GEMSTONES:

Zircon (high, medium.....)	4.70 ($\pm .03$)
Corundum (sapphire).....	4.00 ($\pm .05$)
Benitoite*	3.64
Topaz	3.53 ($\pm .04$)
Apatite*	3.18
Euclase*	3.10
Tourmaline	3.08 ($\pm .04$)
Beryl (aquamarine)	2.72 ($-.05 +.12$)
Labradorite feldspar	2.69 ($\pm .01$)
Quartz (dyed).....	2.66 ($\pm .01$)
Chalcedony (dyed and natural).....	2.61 ($\pm .03$)
Iolite*	2.63

Preceding tests will have separated apatite, tourmaline and euclase, as well as iolite, feldspar and quartz.

SPECIFIC GRAVITY OF NATURAL, SINGLY REFRACTIVE, TRANSPARENT, BLUE GEMSTONES:

Spinel	3.60 ($-.03, +.30$)
Diamond	3.52 ($\pm .01$)
Fluorite*	3.18 ($\pm .01$)
Opal	2.15 ($\pm .08$)

The specific gravity range in this group is sufficiently great so that a careful determination will give the correct identification, and eliminate the necessity for further tests.

SPECIFIC GRAVITY OF ARTIFICIAL, DOUBLY REFRACTIVE, TRANSPARENT, BLUE GEM MATERIAL:

Synthetic corundum.....	4.00 ($\pm .03$)
-------------------------	--------------------

Since synthetic corundum is the only truly doubly refractive substitute for a natural blue gem, determination of double refraction and characteristic inclusions visible under magnification would have eliminated it before this stage in the identification had been reached.

**Gems infrequently encountered in the jewelry trade.*

Identification of Transparent Blue Gemstones

SPECIFIC GRAVITY OF ARTIFICIAL, SINGLY REFRACTIVE, TRANSPARENT, BLUE GEM MATERIALS:

Glass	2.3 to 4.5
Synthetic spinel.....	3.60 (\pm .16)
Plastics less than 2.0—with rare exceptions they float in Carbona (density 1.59).	

The specific gravity of glass can be the same as that of synthetic spinel, in which case the typical "cross-hatched" appearance due to anomalous double refraction in synthetic spinel will distinguish it (see illustration on page 113). Since neither is valuable, the hardness test can be used. Glass is easily scratched by a steel file, but synthetic spinel is not.

Seventh Test. Hardness should be used in the identification of transparent gems only as a last resort. If the gemologist has the necessary instruments to make a positive identification by the foregoing procedure, a hardness determination should never be made. (See hardness table, page 9).

HANDBOOK OF GEM IDENTIFICATION

Transparent Gems and Their Substitutes that Occur in a BLUE Color.

First Test Initial Examination	*Apatite *Benitoite Beryl Corundum Diamond *Euclase	*Fluorite Glass *Iolite *Labradorite Opal Plastics	Quartz (dyed) Spinel Synthetic Corundum Synthetic Spinel	Topaz Tourmaline Zircon Doublets Triplets			
Second Test Magnification to Determine Shape of Inclusions, etc.	Natural Gems			Mon-Made			
	*Apatite *Benitoite Beryl Corundum Diamond	*Euclase *Fluorite *Iolite *Labradorite Opal	Quartz (dyed) Spinel Topaz Tourmaline Zircon Doublets Triplets	Glass Plastics Synthetic Corundum Synthetic Spinel Doublets or Triplets			
Third Test Immersion	Doublets or Triplets detected or eliminated.						
Fourth Test Single or Double Refraction; Pleochroism.	Natural Singly Refractive		Natural Doubly Refractive	Artificial Singly Refractive			
	Diamond *Fluorite Opal Spinel		Beryl Corundum Quartz Topaz Tourmaline Zircon *Apatite *Benitoite *Euclase *Iolite *Labradorite	Glass Plastics Synthetic Spinel			
Fifth Test Determination of Refractive Index	Diamond	2.41	Zircon	1.92-1.98	Glass	1.44-1.77	Synthetic Corundum
	Spinel	1.72	Corundum	1.76-1.77	Synthetic Spinel	1.73	
Sixth Test Determination of Specific Gravity	Opal	1.45	*Benitoite	1.75-1.80	Lucite	1.50	Synthetic Corundum 4.00
	Fluorite	1.43	*Euclase	1.65-1.67	Bakelite	1.55-1.67	
Seventh Test Hardness			*Apatite	1.64-1.65	Polystyrene	1.59-1.67	
			Tourmaline	1.62-1.64			
			Topaz	1.61-1.62			
			Beryl	1.57-1.58			
			*Labradorite	1.56-1.57			
			Quartz	1.54-1.55			
			*Iolite	1.54-1.55			
	Spinel	3.60	Zircon	4.70	Glass	2.3-4.5	
	Diamond	3.52	Corundum	4.00	Synthetic Spinel	3.60	
	*Fluorite	3.18	*Benitoite	3.64	Plastics, less than	2.0	
	Opal	2.15	Topaz	3.53			
			*Apatite	3.18			
			Euclase	3.10			
			Tourmaline	3.08			
			Beryl	2.72			
			*Labradorite	2.69			
			Quartz	2.66			
			*Iolite	2.63			
Seventh Test Hardness	Do not use unless it is essential.						
<i>*Gems infrequently encountered in the jewelry trade.</i>							

Chapter XVII

The Identification of Transparent Green Gemstones and Their Substitutes

The important transparent gems and gem substitutes that occur in a green color are:

Andradite garnet (demantoid)	Spinel
Beryl (emerald)	Synthetic corundum
Chrysoberyl (including cat's-eye and alexandrite)	Synthetic emerald
Corundum (green sapphire)	Synthetic spinel
Diamond	Topaz
Glass	Tourmaline
Peridot	Zircon
Plastics	Doublets
Chalcedonic quartz (chrysoprase)	Triplets

Gems infrequently encountered in the jewelry trade:

Andalusite	Sphene
Fluorite	Spodumene (hiddenite)
Grossularite garnet	

Descriptions of Transparent Green Gemstones and Their Substitutes. ANDRADITE GARNET (DEMANTOID) occurs in light to medium tones of green to yellow-green. It is characterized by the strongest dispersion (fire) of any gem, and by its high luster. BERYL (EMERALD) occurs in medium tones of intense blue-green. Beryl in light tones of green and yellow-green is called green beryl. The emerald variety has a soft velvety appearance. It is often flawed visibly. CHRYSOBERYL has three varieties that occur in a green color. CAT'S-EYE and ordinary chrysoberyl are found in light to medium tones of greenish-yellow to yellowish-green hues. The ALEXANDRITE variety assumes

a medium to dark yellowish-green hue in daylight, and is dark red under artificial light. CORUNDUM occurs in light to medium tones of yellow-green to green hues. It is more brilliant than emerald. DIAMOND is found in very light to medium tones of green, but a green hue may be imparted by bombardment in a cyclotron or by radium emanations. GLASS imitations of emerald have been made that are indistinguishable from emerald by the unaided eye. PERIDOT occurs in light to dark tones of yellow-green to yellowish-green hues (often called bottle-green). The strong birefringence of the gem lends a distinctive soft appearance. PLASTICS are molded in faceted shapes to imitate emerald. CHALCEDONIC QUARTZ (CHRYSOPRASE), both natural and dyed occurs in light to medium tones of yellowish-green. SPINEL in medium to very dark tones of bluish-green to greenish-blue is rarely encountered. SYNTHETIC CORUNDUM is made in light to medium tones of yellowish-green. SYNTHETIC EMERALD (the only variety of beryl synthesized) is still rare in the trade. The synthetic closely resembles natural emerald of fine quality. SYNTHETIC SPINEL is made in light tones of yellow-green. TOPAZ occurs in very light tones of yellowish-green to bluish-green hues. TOURMALINE occurs in several tones and intensities of yellow-green, green and blue-green hues. ZIRCON of the low property sub-species is common in light to dark tones of yellow-green to green hues. DOUBLETS were once made that closely imitated the color of emerald. They included garnet, quartz or beryl with glass, as well as genuine doublets. Green doublets are still common in the jewelry trade. TRIPLETS are still common substitutes for emerald.

GEMS INFREQUENTLY ENCOUNTERED IN THE JEWELRY TRADE.

ANDALUSITE is occasionally used as a gem when it changes from light to dark yellow-green in daylight to reddish-brown under artificial light. FLUORITE is common in light to medium tones of green, but is too fragile to be frequently used as a gem. GROSSULARITE GARNET is not uncommon in a medium tone of yellowish-green hue, but it is rarely transparent. SPHENE occurs

Identification of Transparent Green Gemstones

in a range of colors from light yellow-green to medium tones of green. It is distinguished by its strong dispersion and extreme birefringence. **SPODUMENE (HIDDENITE)** occurs in very light to medium tones of yellow-green to yellowish-green hues.

Testing Procedure. Caution: So many transparent gems occur in a green color that tests must be made carefully. One careless test may lead to an incorrect conclusion regarding the identity of the material.

It should be emphasized that it is not necessary to make all the tests indicated in identifying every stone. However, unless a gem is determined to be a doublet or triplet or shows inclusions characteristic of a synthetic, a determination is rarely positive until tests have been carried through the refractive index reading.

First Test. Clean the stone and examine it with the unaided eye or a low power loupe for any unusual property or appearance. In this preliminary examination, observation of any of the following properties may facilitate identification:

An exceedingly low specific gravity is often noticeable in plastic imitations, when a large stone is lifted.

Warmth to the touch (compared to the cold feel of crystalline materials), suggests glass or a plastic.

A luster difference between crown and pavilion or between table and the lower crown facets suggests a doublet or triplet.

Strong dispersion suggests andradite garnet (demantoid), sphene or diamond.

Unusually dull luster suggests fluorite.

Adamantine luster suggests diamond.

A visible separation plane indicates a doublet or triplet.

Molded back facets prove the unknown to be a glass or plastic imitation. (See Chapter XI).

A red ring around the girdle when the gem is placed table down on a white background suggests a garnet or glass doublet.

Double images of back facet edges may be visible to the unaided eye in sphene, zircon or peridot.

Second Test. Examine the gem under high magnification (30X to 60X or higher, if necessary).^{*} The magnification test often does more than distinguish between natural and man-made gems, since it makes possible the observation of the inclusions which often characterize a single natural gem species.

Characteristic inclusions of natural and synthetic green gemstones are described and illustrated in Chapter VIII. Angular inclusions characterize natural green gems; spherical bubbles, or curved striae, prove artificial origin.

Magnification often reveals double images of pavilion facet edges or of inclusions. In this event, the polariscope test is eliminated, hastening the final identification. If double images accompany the spherical bubbles that prove artificial origin, the unknown must be synthetic corundum, since synthetic corundum is the only man-made double refractive green gem with such inclusions.

ANGULAR INCLUSIONS REVEALED UNDER HIGH MAGNIFICATION INDICATE THE FOLLOWING NATURAL, TRANSPARENT, GREEN GEMSTONES:

Andradite garnet (demantoid)	Spinel
Beryl (emerald)	Topaz
Chrysoberyl (including cat's-eye and alexandrite)	Tourmaline
Corundum (green sapphire)	Zircon
Diamond	Doublets and triplets partially or wholly made of genuine materials.
Peridot	
Quartz	
Chalcedony	

(Synthetic emerald has inclusions which suggest natural origin).

Gems infrequently encountered in the jewelry trade.

Andalusite	Sphene
Fluorite	Spodumene
Grossularite garnet	(hiddenite)

^{*}If not available, use a 10X or 20X loupe.

Identification of Transparent Green Gemstones

TRANSPARENT GREEN MATERIALS CONTAINING INCLUSIONS CHARACTERISTIC OF ARTIFICIAL ORIGIN:

Glass	Synthetic spinel
Synthetic corundum	Doublets or triplets partially composed of glass or wholly
Plastics	genuine materials with bub- bles in the joining plane.
Synthetic emerald (wisp-like inclusions)	

Third Test. Immerse the gem in a liquid of intermediate to high refractive index to detect a doublet or triplet, or to re-examine it if no inclusions were discovered in the second test. (See Chapter VII). The presence of a separation plane across the gem may now identify it as a doublet or triplet, in which case no test, other than one to determine the nature of the portions of the assembled stone, need be made. Thus, doublets and triplets are either detected or eliminated by this test.

If it is difficult to resolve the gem's inclusions with an ordinary microscope, it may be because the gem is of high refractive index, therefore highly reflective, especially if the gem is brilliant-cut. In this event, or if no inclusions were visible on first examination under high magnification, immerse the gem in bromoform or methylene iodide to reduce reflections and improve the view of its interior. Re-examine it very carefully, but bear in mind that some gems are without identifying flaws under *any* feasible magnification.

Fourth Test. Examine the gem in the polariscope or under a polarizing microscope, to test it for single or double refraction. Double refraction may also be detected under magnification, on the refractometer, with the dichroscope, or by the reflection test. Since it is not always apparent using the latter methods, failure to discover double refraction by methods other than those involving the polariscope or polarizing microscope is *not* proof of single refraction. Directions for use of the instruments for detection of single and double refraction are given in Chapter VI. (For optic character table, see Appendix.)

HANDBOOK OF GEM IDENTIFICATION

On the basis of one or more of the tests for single and double refraction and the previous tests, the gem can be assigned to one of the following groups:

1. DOUBLY REFRACTIVE, TRANSPARENT, NATURAL GREEN GEMS:

Andalusite*	Quartz
Beryl (emerald)	Chalcedony (chrysoprase)
Chrysoberyl (including cat's eye and alexandrite)	Sphene*
Corundum	Spodumene (hiddenite)*
Peridot	Topaz
	Tourmaline
	Zircon

2. SINGLY REFRACTIVE, TRANSPARENT, NATURAL GREEN GEMS:

Andradite garnet (demantoid)	Fluorite*
Diamond	Grossularite garnet
	Spinel

3. DOUBLY REFRACTIVE, TRANSPARENT, ARTIFICIAL GREEN GEM MATERIALS:

Synthetic corundum	Synthetic emerald
--------------------	-------------------

4. SINGLY REFRACTIVE, TRANSPARENT, ARTIFICIAL GREEN GEM MATERIALS:

Glass	Synthetic spinel
Plastics	

Synthetic spinel almost invariably exhibits strong anomalous double refraction. The effect observed is a "cross-hatched" appearance in the dark (crossed Nicols) position of the polariscope or polarizing microscope. (See Figure 84.)

If the gem proves to be doubly refractive, TEST IT FOR PLEOCHROISM, using the dichroscope, polariscope or polarizing microscope. The following gems often display STRONG DICHROISM. Their characteristic dichroic colors follow:

**Gems infrequently encountered in the jewelry trade.*

Identification of Transparent Green Gemstones

Brownish-green and dark red — andalusite.

Green and blue-green — beryl (emerald).

Blue-green to dark green and yellow-green — tourmaline.

The following gems often display distinct dichroism. Their characteristic dichroic colors follow:

Brownish-green and blue-green — sphene.

Blue-green and light green — topaz.

Weak dichroism is of little value in the identification of green stones, since most of the pale gems exhibit little or no color difference.

The only green gem which shows **STRONG TRICHOISM** is the *alexandrite variety of chrysoberyl*. Its trichroic colors are *dark red, orange and green*.

The emerald filter may be used to separate emerald, demantoid, green zircon and synthetic emerald from other green gemstones and substitutes. Only the four named appear red through the filter.

Now it has been established that the gem occurs in one of the four groups listed under the fourth test. In addition, characteristic inclusions, dichroism, the appearance through the emerald filter or luster may have proved useful as clues to the identity of the unknown gem. Usually the determination of refractive index will positively identify the gem at this point in the procedure.

Fifth Test. Mount the stone on a refractometer to determine the refractive index. Unless the refractometer reading is a value midway between the figures given for two gems in the tables that follow, a careful reading will leave no doubt as to the gem's identity. If no reading is obtained, or if the reading is inconclusive, an approximate index may be determined in some cases by means of the apparent depth method, or the approximate immersion method. If no index value is obtained, proceed to the next test. (For optic character table, see Appendix.)

HANDBOOK OF GEM IDENTIFICATION

PRINCIPAL INDICES OF NATURAL, DOUBLY REFRACTIVE, TRANSPARENT, GREEN GEMSTONES:

Sphene*	1.900	to 2.034
Zircon (low)	1.810	to 1.815
Corundum	1.762 (−.003, +.007)	to 1.770 (−.003, +.008)
Chrysoberyl	1.746 (±.004)	to 1.755 (−.005)
Peridot	1.659 (−.010, +.004)	to 1.697 (−.012, ±.003)
Spodumene*	1.660 (±.005)	to 1.676 (±.005)
Andalusite*	1.634	to 1.643
Tourmaline	1.624 (±.005)	to 1.644 (±.006)
Topaz	1.619 (±.012)	to 1.627 (±.012)
Beryl (emerald).....	1.577 (±.016)	to 1.583 (±.017)
Synthetic emerald	1.570	to 1.575
Chalcedonic quartz (chrysoprase)	1.535	to 1.539

Synthetic emerald may be distinguished from natural emerald by its red fluorescence under ultra-violet radiation of 2500Å. or 3500Å. Natural emerald fails to fluoresce deep red.

If difficulty is encountered in distinguishing corundum from chrysoberyl by means of the difference in the refractive index readings, a specific gravity determination will separate the two. Peridot is easily distinguished from spodumene, and topaz from tourmaline, by the next test.

INDICES OF NATURAL, SINGLY REFRACTIVE, TRANSPARENT, GREEN GEMSTONES:

Diamond	2.417
Andradite garnet	1.885
Grossularite garnet*.....	1.745 (±.005)
Spinel	1.726 (±.014)
Fluorite*	1.434 (±.00)

INDICES OF ARTIFICIAL, SINGLY REFRACTIVE, TRANSPARENT, GREEN GEM MATERIALS:

Synthetic corundum	1.76 to 1.77
Synthetic emerald.....	1.570 to 1.575

*Gems infrequently encountered in the jewelry trade.

Identification of Transparent Green Gemstones

INDICES OF ARTIFICIAL, SINGLY REFRACTIVE, TRANSPARENT, GREEN GEM MATERIALS:

Glass (extreme range of gem imitation types).....	1.44-1.77
Glass (normal range)	1.48-1.70
Synthetic spinel.....	1.73 ($\pm .010$)
Plastics — celluloid	1.49-1.52
plexiglass and lucite.....	1.50
bakelites	1.55-1.67
polystyrene	1.59-1.67

(Maximum range for plastics 1.49-1.67).

Sixth Test. Test the gem for specific gravity on the diamond balance, or with high-density liquids. It is rarely necessary to determine specific gravity, since the gem should have been identified by the time the refractive index reading has been made.

SPECIFIC GRAVITY OF NATURAL, DOUBLY REFRACTIVE, TRANSPARENT, GREEN GEMSTONES:

Zircon (low).....	4.00 ($\pm .07$)
Corundum (green sapphire).....	4.00 ($\pm .05$)
Chrysoberyl (including cat's-eye and alexandrite).....	3.73 ($\pm .02$)
Topaz	3.53 ($\pm .04$)
Sphene*	3.52 ($\pm .02$)
Peridot	3.40 ($\pm .08$)
Spodumene (hiddenite)*	3.18 ($\pm .03$)
Andalusite*	3.17 ($\pm .04$)
Tourmaline	3.08 ($\pm .04$)
Beryl (emerald).....	2.72 ($-.05, +.12$)
Quartz	2.66 ($\pm .01$)
Chalcedonic quartz.....	2.61 ($\pm .03$)

Topaz and sphene are easily distinguished by refractive index or by the strong birefringence of sphene. Corundum is separated from zircon (low property) by refractive index, or by characteristic inclusions. Spodumene and andalusite are easily separated by dichroism or refractive index.

SPECIFIC GRAVITY OF NATURAL, SINGLY REFRACTIVE, TRANSPARENT, GREEN GEMSTONES:

Andradite garnet	3.84
Grossularite garnet*	3.61 ($-.04, +.12$)
Spinel	3.60 ($-.03, +.30$)
Diamond	3.52 ($\pm .01$)
Fluorite*	3.18 ($\pm .01$)

*Gems infrequently encountered in the jewelry trade.

HANDBOOK OF GEM IDENTIFICATION

Grossularite garnet and spinel are distinguished by a refractometer reading or by their characteristic inclusions.

SPECIFIC GRAVITY OF ARTIFICIAL, DOUBLY REFRACTIVE, TRANSPARENT, GREEN GEM MATERIALS:

Synthetic corundum.....	4.00 ($\pm .03$)
Synthetic emerald.....	2.68

SPECIFIC GRAVITY OF ARTIFICIAL, SINGLY REFRACTIVE, TRANSPARENT, GREEN GEM MATERIALS:

Glass	2.3 to 4.5
Synthetic spinel.....	3.60 ($\pm .14$)
Plastics less than 2.0—with rare exceptions they float in Carbona (density 1.59).	

The specific gravity of glass can be the same as that of synthetic spinel, in which case the typical "cross-hatched" appearance due to anomalous double refraction in synthetic spinel will distinguish it (see illustration on page 113). Since neither is valuable, the hardness test can be used. Glass is easily scratched by a steel file, but synthetic spinel is not.

Seventh Test. Hardness should be used in the identification of transparent gems only as a last resort. If the gemologist has the necessary instruments to make a positive identification by the foregoing procedure, a hardness determination should never be made. See hardness table, Page 9).

Identification of Transparent Green Gemstones

Transparent Gems and Their Substitutes that Occur in a GREEN Color.				
First Test Initial Examination	Andradite *Andalusite Beryl Chrysoberyl Corundum Diamond *Fluorite	Glass Grossularite Peridot Plastics Quartz (Chalcedony) *Sphe	Spinel *Spodumene Synthetic Corundum Synthetic Emerald Synthetic	Spinel Topaz Tourmaline Zircon Doublets Triplets
Second Test Magnification to Determine Shape of Inclusions, etc.	Natural Gems			Men-Made
	Andradite *Andalusite Beryl Chrysoberyl Corundum Diamond *Fluorite *Grossularite Peridot	Quartz (Chalcedony) *Sphe Spinel *Spodumene Topaz Tourmaline Zircon Doublets Triplets		Glass Plastics Synthetic Corundum Synthetic Emerald Synthetic Spinel Doublets Triplets Foilbacks
Third Test Immersion	Doublets or Triplets detected or eliminated.			
Fourth Test Single or Double Refraction	Genuine Singly Refractive	Genuine Doubly Refractive	Artificial Singly Refractive	Artificial Doubly Refractive
	Andradite *Fluorite Diamond *Grossularite Spinel	*Andalusite Beryl Chrysoberyl Corundum Peridot Quartz Chalcedony *Sphe *Spodumene Topaz Tourmaline Zircon	Glass Plastics Synthetic Spinel	Synthetic Corundum Synthetic Emerald
Fifth Test Pleochroism Determination of Refractive Index	Diamond 2.417 Andradite 1.885 *Grossularite 1.745 Spinel 1.726 *Fluorite 1.434	Zircon 1.925-1.984 *Sphe 1.900-2.034 Corundum 1.762-1.770 Chrysoberyl 1.746-1.755 *Spodumene 1.660-1.676 Peridot 1.659-1.697 *Andalusite 1.634-1.643 Tourmaline 1.624-1.644 Topaz 1.619-1.627 Beryl 1.577-1.585 Quartz (Chalcedony) 1.535-1.539	Glass 1.44-1.77 Synthetic Spinel 1.73 Plastics—Celluloid 1.49-1.52 Plexiglass 1.50 Bakelites 1.55-1.67 Polystyrene 1.59-1.67	Synthetic Corundum 1.76-1.77 Synthetic Emerald 1.57-1.575
Sixth Test Determination of Specific Gravity	Andradite 3.84 *Grossularite 3.61 Spinel 3.60 Diamond 3.52 *Fluorite 3.18	Zircon 4.70 Corundum 4.00 Chrysoberyl 3.73 Topaz 3.53 *Sphe 3.52 Peridot 3.40 *Spodumene 3.18 *Andalusite 3.17 Tourmaline 3.08 Beryl 2.72 Chalcedony 2.61	Glass 2.3-4.5 Synthetic Spinel 3.60 Plastics, less than 2.00	Synthetic Corundum 4.00 Synthetic Emerald 2.63
Seventh Test Hardness	Do not use unless it is essential.			
<i>*Gems infrequently encountered in the jewelry trade.</i>				

Chapter XVIII

The Identification of Transparent Yellow Gemstones and Their Substitutes

Transparent gems and their substitutes that are found in a yellow color include the following:

Amber	Quartz (citrine)
Bakelite (and other plastics)	Spodumene
Beryl	Synthetic corundum
Chrysoberyl (including cat's-eye)	Synthetic spinel
Corundum (sapphire)	Topaz
Diamond	Tourmaline
Glass	Zircon
Grossularite garnet (hessonite)	Doublets
Opal	Tripets
Peridot	Foil backs

**Gems infrequently encountered in the jewelry trade.*

Apatite	Phenacite
Beryllonite	Sphene
Brazilianite	Spinel
Orthoclase	

Description of Transparent Yellow Gemstones and Their Substitutes. AMBER occurs frequently in medium tones of yellow-brown. It is warm to the touch and its low specific gravity is apparent to the hand. BAKELITE appears as an amber substitute or as a molded faceted gem to simulate topaz. BERYL occurs in a wide variety of pleasing tones of yellow. CHRYSOBERYL when transparent tends toward greenish-yellow to yellow-green hues. Cat's-eye is usually found in the same hues and also pure yellow. Chrysoberyl has a higher luster than beryl or topaz. CORUNDUM (both natural and synthetic) is found in very light to medium tones of yellow. Such a color can be temporarily in-

Identification of Transparent Yellow Gemstones

duced by X-radiation in natural material. Yellow sapphire is more lustrous and brilliant than beryl, citrine, or topaz. DIAMOND is easily distinguished by its adamantine luster, brilliancy, and fire. GLASS is made in many tones and intensities of a yellow hue. It often shows too much fire for topaz, beryl, or quartz. GROSSULARITE GARNET (HESSONITE) is usually orangy-yellow. Its numerous inclusions are commonly visible to the unaided eye. OPAL in a yellow hue with little or no play of color is not uncommon. PERIDOT is rarely yellow, but is not uncommon in a greenish-yellow hue. Its strong birefringence gives it a soft, blurred internal appearance. QUARTZ (CITRINE) occurs in light to dark yellow. It lacks distinguishing features to the unaided eye. Yellow SPODUMENE is not uncommon, but is usually very pale. Yellow is one of the many colors in which SYNTHETIC SPINEL has been produced. TOPAZ is not uncommon in very light to medium tones of yellow to yellow-brown. It is usually characterized by a soft, velvety appearance, and is more brilliant than citrine. TOURMALINE of a yellow hue is not common, but light to dark tones of yellow to yellow-brown tourmaline are occasionally encountered in the jewelry trade. ZIRCON of brownish-yellow and orangy-yellow hue is frequently cut. It is usually of medium tone. DOUBLETS of a yellow hue are usually garnet and glass. Triplets and foil backs in a yellow color are rare.

GEMS INFREQUENTLY ENCOUNTERED IN THE JEWELRY TRADE.

APATITE of a lovely yellow hue occurs, but is rarely cut as a gem because of its low hardness (5). BERYLLONITE in light to very light tones of yellow is occasionally cut as a gem. BRAZILIANITE, the newly discovered gem species, occurs in medium tones of greenish-yellow to yellowish-green. ORTHOCLASE of a clear light to medium tone of yellow is not infrequently cut into faceted gems. PHENACITE, a very rare mineral, is occasionally found in light to very light yellow and cut as a gem. SPHENE is rarely of gem quality in nature, but greenish-yellow material makes an attractive gem. Natural SPINEL is rarely found in a yellow hue.

Testing Procedure. CAUTION: So many transparent gems occur in a yellow color that tests must be made carefully. One careless test may lead to an incorrect conclusion regard the identity of the material.

It should be emphasized that it is not necessary to make all the tests indicated in identifying every stone. However, unless a gem is determined to be a doublet, triplet or foil back, or shows inclusions characteristic of a synthetic, a determination is rarely positive until tests have been carried though the refractive index reading.

First Test. Clean the stone and examine it with the unaided eye or low power loupe for any unusual property or appearance. In this preliminary examination, observation of any of the following properties may facilitate identification:

Double images of back facet edges suggests zircon, peridot or sphene.

An exceedingly low specific gravity apparent upon lifting the gem suggests amber or a plastic imitation.

Warmth to the touch (compared to the cold feel of crystalline materials) is a property of amorphous materials such as opal, and glass and plastic imitations.

A cat's-eye appearance suggests chrysoberyl or quartz.

Strong dispersion suggests sphene, zircon or diamond.

Molded pavilion facets (See Chapter XI) prove the unknown to be a glass or plastic imitation.

A play of color is characteristic of opal.

A luster difference between crown and pavilion or between the table and lower crown facets suggests a doublet.

A red ring around the girdle when the gem is placed table down on a white background suggests a garnet-and-glass doublet.

Second Test. Examine the gem under high magnification (30X to 60X or higher, if necessary).* Magnification often does more than distinguish between natural and man-made gems, since

*If not available, use a 10X to 20X loupe.

Identification of Transparent Yellow Gemstones

it makes possible the observation of the inclusions which often characterize a single natural gem species.

Characteristic inclusions of natural and synthetic yellow gemstones are described and illustrated in Chapter VIII. Angular inclusions characterize gems of natural origin; spherical bubbles or curved striae, prove artificial origin.

Magnification often reveals double images of pavilion facet edges or of inclusions. In this event, the polariscope test is eliminated, hastening the final identification. If double images accompany the spherical bubbles that prove artificial origin, the unknown must be synthetic corundum, since synthetic corundum is the only man-made doubly refractive yellow gem.

Inclusions characteristic of a single gem species also identify an unknown at this point.

ANGULAR INCLUSIONS REVEALED UNDER HIGH MAGNIFICATION INDICATE THE FOLLOWING NATURAL, TRANSPARENT, YELLOW GEMSTONES:

Amber	Quartz (citrine)
Beryl	Spodumene
Chrysoberyl	Topaz
Corundum (sapphire)	Tourmaline
Diamond	Zircon
Grossularite garnet (hessonite)	Doublets, triplets, and foil
Opal	backs partially or wholly made
Peridot	of genuine materials.

Gems infrequently encountered in the jewelry trade:

Apatite	Phenacite
Beryllonite	Sphene
Brazilianite	Spinel
Orthoclase	

TRANSPARENT YELLOW MATERIALS CONTAINING INCLUSIONS CHARACTERISTIC OF ARTIFICIAL ORIGIN:

Bakelite (or other plastics)	Doublets or triplets partially
Glass	composed of glass or wholly
Synthetic corundum	genuine materials with bub-
Synthetic spinel	bles in the joining plane.

Third Test. Immerse the gem in a liquid of intermediate to high refractive index to detect a doublet or triplet, or to re-examine it if no inclusions were discovered in the second test.

(See Chapter VII). The presence of a separation plane across the gem may now identify it as a doublet or triplet, in which case no test, other than one to determine the nature of the portions of the assembled stone, need be made. Thus, doublets and triplets are either detected or eliminated by this test.

If it is difficult to resolve the gem's inclusions with an ordinary microscope, it may be because the gem is of high refractive index, therefore highly reflective, especially if the gem is brilliant-cut. In this event, or if no inclusions were visible on first examination under high magnification, immerse the gem in bromoform or methylene iodide to reduce reflections and improve the view of its interior. Re-examine it very carefully, but bear in mind that some gems are without identifying flaws under *any* feasible magnification.

Fourth Test. Examine the gem in the polariscope or under a polarizing microscope, to test it for single or double refraction. Double refraction may also be detected under magnification, on the refractometer, with the dichroscope, or by the reflection test. Since it is not always apparent using the latter methods, failure to discover double refraction by methods other than those involving the polariscope or polarizing microscope is NOT proof of single refraction. Directions for use of the instruments for detection of single and double refraction are given in Chapter VI. (For optic character table, see Appendix.)

On the basis of one or more of the tests for single and double refraction and the previous tests, the gem can be assigned to one of the following groups:

1. DOUBLY REFRACTIVE, TRANSPARENT, NATURAL YELLOW GEMS:

Beryl	Spodumene
Chrysoberyl	Topaz
Corundum (sapphire)	Tourmaline
Peridot	Zircon
Quartz (citrine)	

Gems infrequently encountered in the jewelry trade:

Apatite	Orthoclase
Beryllonite	Phenacite
Brazilianite	Sphene

Identification of Transparent Yellow Gemstones

2. SINGLY REFRACTIVE, TRANSPARENT, NATURAL YELLOW GEMS:

Amber	Grossularite garnet (hessonite)
Diamond	Opal

Gems infrequently encountered in the jewelry trade:

Spinel

3. DOUBLY REFRACTIVE, TRANSPARENT, ARTIFICIAL YELLOW GEM MATERIALS:

Synthetic corundum

4. SINGLY REFRACTIVE, TRANSPARENT, ARTIFICIAL YELLOW GEM MATERIALS:

Bakelite
Glass

Synthetic spinel

Synthetic spinel almost invariably exhibits strong anomalous double refraction in the form of a "cross-hatched" appearance in the dark (crossed Nicols) position of the polariscope or polarizing microscope (See Figure 84).

If the gem proves to be doubly refractive, TEST IT FOR PLEOCHROISM, using the dichroscope, polariscope or polarizing microscope. Unfortunately, since no yellow gem shows very strong pleochroism, this test serves only as an indication of a gem's identity.

Dichroism may occasionally serve to identify the following gemstones:

Dark yellow and light yellow — tourmaline.

Colorless and orange yellow — phenacite.

Yellow and light yellow — golden sapphire.

Now the gem has been determined as occurring in one of the four groups listed under the fourth test. In addition, characteristic inclusions, dichroism and luster may have been of additional assistance in identifying the unknown gem. Usually the next test, for the refractive index reading, will result in positive identification of the gem.

Fifth Test. Examine the stone on a refractometer to determine the refractive index. Unless the refractometer reading

HANDBOOK OF GEM IDENTIFICATION

is a value midway between the figures given for two gems in the tables that follow, a careful reading will leave no doubt as to the gem's identity. If no reading is obtained, or if the reading is inconclusive, an approximate index may be determined in some cases by means of the apparent depth method, or the approximate immersion method. If no index value is obtained, proceed to the next test.

INDICES OF NATURAL, DOUBLY REFRACTIVE, TRANSPARENT, YELLOW GEMS:

Zircon (high, medium).....	1.925	to 1.984
Sphene*	1.900	to 2.034
Zircon (low).....	1.810	to 1.815
Corundum (sapphire)	1.762 (−.003, +.007)	to 1.770 (−.003, +.008)
Chrysoberyl	1.746 (±.004)	to 1.755 (±.005)
Peridot	1.659 (−.010, +.004)	to 1.697 (−.012, +.003)
Spodumene	1.660 (±.005)	to 1.676 (±.005)
Phenacite*	1.654	to 1.670
Apatite*	1.642	to 1.646
Tourmaline	1.624 (±.005)	to 1.644 (±.006)
Topaz	1.619 (±.012)	to 1.627 (±.012)
Brazilianite*	1.598	to 1.617
Beryl*	1.577 (±.016)	to 1.583 (±.017)
Beryllonite*	1.552	to 1.562
Quartz (citrine)	1.544	to 1.553
Orthoclase*	1.518	to 1.526

If difficulty is encountered in distinguishing corundum from chrysoberyl by means of the difference in the refractive index readings, a specific gravity determination will separate the two gemstones. Peridot is easily distinguished from spodumene, and topaz from tourmaline by the next test.

INDICES OF NATURAL, SINGLY REFRACTIVE, TRANSPARENT, YELLOW GEMSTONES:

Diamond	2.417
Grossularite garnet (hessonite)	1.745 (±.005)
Spinel*	1.726 (±.014)
Amber	1.54
Opal	1.45

INDICES OF ARTIFICIAL, DOUBLY REFRACTIVE, TRANSPARENT, YELLOW GEM MATERIAL:

Synthetic corundum	1.76-1.77
--------------------------	-----------

*Gems infrequently encountered in the jewelry trade.

Identification of Transparent Yellow Gemstones

INDICES OF ARTIFICIAL, SINGLY REFRACTIVE, TRANSPARENT, YELLOW GEM MATERIALS:

Synthetic spinel.....	1.76 ($\pm .015$)
Bakelite	1.55-1.67
Other plastics.....	1.49-1.65
Glass (extreme range of gem imitation types).....	1.44-1.77
Glass (normal range).....	1.48-1.70

To distinguish between glass and bakelite, a specific gravity test is necessary.

Sixth Test. Test the gem for specific gravity on the diamond balance, or with high-density liquids, which are easily obtainable for specific gravities less than 3.32.

SPECIFIC GRAVITY OF NATURAL, DOUBLY REFRACTIVE, TRANSPARENT, YELLOW GEMSTONES:

Zircon (high, medium).....	4.70 ($\pm .03$)
Zircon (low).....	4.00 ($\pm .07$)
Corundum (sapphire).....	4.00 ($\pm .05$)
Chrysoberyl	3.73 ($\pm .02$)
Topaz	3.53 ($\pm .04$)
Sphene*	3.52 ($\pm .02$)
Peridot	3.40 ($\pm .08$)
Apatite*	3.20 ($\pm .03$)
Spodumene	3.18 ($\pm .03$)
Tourmaline	3.07 ($\pm .03$)
Phenacite*	2.95 ($\pm .02$)
Brazilianite*	2.94
Beryllonite	2.85 ($\pm .04$)
Beryl	2.72 ($-.05, +.12$)
Quartz (citrine)	2.66 ($\pm .01$)
Orthoclase*	2.56 ($\pm .01$)

Topaz and sphene are easily distinguished by refractive index or by the strong birefringence of sphene. Corundum is separated from zircon (low property) by refractive index, or by characteristic inclusions.

SPECIFIC GRAVITY OF NATURAL, SINGLY REFRACTIVE, TRANSPARENT, YELLOW GEMSTONES:

Grossularite garnet (hessonite).....	3.61 ($-.04, +.12$)
Spinel*	3.60 ($-.03, +.30$)
Diamond	3.52 ($\pm .01$)
Opal	2.15 ($\pm .08$)
Amber	1.08 ($\pm .02$)

*Gems infrequently encountered in the jewelry trade.

HANDBOOK OF GEM IDENTIFICATION

Grossularite and spinel are usually distinguished by a refractive index reading, but are easily distinguished by characteristic inclusions if no reading can be made.

SPECIFIC GRAVITY OF ARTIFICIAL, DOUBLY REFRACTIVE, TRANSPARENT, YELLOW GEM MATERIAL:

Synthetic corundum 4.00 ($\pm .03$)

SPECIFIC GRAVITY OF ARTIFICIAL, SINGLY REFRACTIVE, TRANSPARENT, YELLOW GEM MATERIALS:

Synthetic Spinel..... 3.60 ($-.01, +.15$)
 Glass 2.3 -4.5
 Bakelite 1.25-1.28
 Other plastics 1.18-1.55

The specific gravity of glass could be the same as that of synthetic spinel, in which case the typical "cross-hatched" appearance of anomalous double refraction in the synthetic will distinguish it (see illustration on page 113). Since neither is valuable, the hardness test can be used. Glass is easily scratched by a steel file, but synthetic spinel is not.

Seventh Test. Hardness should be used in the identification of transparent gems only as a last resort. If the gemologist has the necessary instruments to make a positive identification by the foregoing procedure, a hardness determination should never be made. (See hardness table, page 9).

Transparent Gems and Their Substitutes that Occur in a YELLOW Color.				
First Test Initial Examination	Amber *Apatite Beryl *Beryllonite *Brazilianite Chrysoberyl	Corundum Diamond Glass Grossularite Opal *Orthoclase Peridot	*Phenacite Plastics Quartz *Sphe *Spinel Spodumene Synthetic Corundum	Synthetic spinel Topaz Tourmaline Zircon Doublets Triplets
	Natural Gems			Man-Made
Second Test Magnification to Determine Shape of Inclusions, etc.	Amber *Apatite Beryl *Beryllonite *Brazilianite Chrysoberyl Corundum Diamond	Grossularite Opal *Orthoclase Peridot *Phenacite Quartz *Sphe *Spinel	Spodumene Topaz Tourmaline Zircon Doublets Triplets	Glass Plastics Synthetic Corundum Synthetic Spinel Doublets Triplets

(Continued on Next Page)

Identification of Transparent Yellow Gemstones

(Continued from Preceeding Page)

Third Test Immersion	Doublets or Triplets detected or eliminated.			
	Natural Singly Refractive	Natural Doubly Refractive	Artificial Singly Refractive	Artificial Doubly Refractive
Fourth Test Single or Double Refraction. Pleochroism	Amber Diamond Grossularite Opal *Spinel	*Apatite Beryl *Beryllonite *Brazilianite Chrysoberyl Corundum *Orthoclase Peridot *Phenacite Quartz *Sphene Spodumene Topaz Tourmaline Zircon	Glass Plastics Synthetic Spinel	Synthetic Corundum
Fifth Test Determination of Refractive Index	Diamond 2.417 Grossularite 1.74 Spinel 1.72 Amber 1.54 Opal 1.45	Zircon 1.925-1.984 Sphene 1.900-2.034 Corundum 1.762-1.770 Chrysoberyl 1.746-1.755 Spodumene 1.660-1.676 Peridot 1.659-1.697 Phenacite 1.651-1.670 *Apatite 1.642-1.646 Tourmaline 1.624-1.644 Topaz 1.619-1.627 Brazilianite 1.598-1.617 Beryl 1.577-1.583 Beryllonite 1.552-1.562 Quartz 1.544-1.553 Orthoclase 1.518-1.526	Synthetic Spinel 1.73 Plastics 1.49-1.67 Glass 1.44-1.77	Synthetic Corundum 1.76-1.77
Sixth Test Determination of Specific Gravity	Grossularite 3.61 *Spinel 3.60 Diamond 3.52 Opal 2.15 Amber 1.08	Zircon 4.70 Corundum 4.00 Chrysoberyl 3.73 Topaz 3.53 *Sphene 3.52 Peridot 3.40 *Apatite 3.20 Spodumene 3.18 Tourmaline 3.07 *Phenacite 2.95 *Brazilianite 2.94 *Beryllonite 2.85 Beryl 2.72 Quartz 2.66 *Orthoclase 2.56	Synthetic Spinel 3.60 Glass 2.3-4.5 Bakelite 1.25-1.28 Other plastics 1.18-1.55	Synthetic Corundum 4.00
Seventh Test Hardness	Do not use unless it is essential.			
<i>*Gems infrequently encountered in the jewelry trade.</i>				

Chapter XIX

The Identification of Transparent Brown and Orange Gemstones and Their Substitutes

TRANSPARENT GEMS and their substitutes that are found in a brown or orange color:

Amber	Quartz (cainrgorm)
Beryl	Chalcedony (carnelian)
Chrysoberyl	Spinel
Copal and other natural resins	Synthetic corundum
Corundum (padparadsha)	Synthetic Spinel
Diamond	Topaz
Glass	Tourmaline
Grossularite garnet (hessonite)	Zircon (hyacinth)
Opal (fire opal)	Doublets
Plastics	Triplets

Gems infrequently encountered in the jewelry trade:

Spessartite garnet	Sphene
--------------------	--------

Descriptions of Transparent Brown and Orange Gemstones and their substitutes. AMBER occurs in light to medium tones of brown to yellow-brown. It often contains insects and can be recognized by its exceedingly low specific gravity. BERYL in light to medium tones of brown to yellow or orange-brown is not uncommon. It is not unlike citrine or cairngorm quartz and topaz in appearance. CHRYSOBERYL is rarely a pure brown, tending toward greenish-brown and red-brown. It may show a color change from artificial to daylight, and/or chatoyancy. COPAL and other natural resins were once common as amber substitutes. CORUNDUM, like chrysoberyl, is rarely pure

Identification of Transparent Brown, Orange Gemstones

brown, but medium to dark reddish-brown and medium tones of yellow-brown corundum are fairly plentiful. The PADPARADSHA variety of corundum occurs in light to medium tones of orange. Corundum is more brilliant and lustrous than beryl, topaz, tourmaline or citrine quartz. DIAMOND is fairly common in medium tones of brown. It is easily recognized by its high luster, brilliance and fire. GLASS is formed in excellent color imitations of topaz. It usually displays more fire than topaz. GROSSULARITE GARNET (HESSONITE) occurs in medium tones of yellowish to orangy-brown in its hessonite variety. Its many inclusions are often visible to the unaided eye. OPAL (FIRE OPAL) without the characteristic play of color occurs in medium tones of orange to orangy-red. PLASTICS were once widely used as substitutes for amber. They are now molded in faceted form to imitate topaz. QUARTZ (CAIRNGORM) is the commonest of gems. It lacks the orangy-brown color of fine quality sherry topaz. The CARNELIAN variety of CHALCEDONIC QUARTZ occurs as a semitransparent gem in a medium tone of brownish-orange to red-orange. SPINEL occurs in intense medium tones of orange-red to orange. SYNTHETIC CORUNDUM is made in colors similar to fine topaz, but is more brilliant and thus lacks the soft, velvety appearance of topaz. It has also been made to resemble the padparadsha variety of corundum. SYNTHETIC SPINEL is manufactured to imitate topaz and also in an orange hue. TOPAZ is found in light tones of yellowish-brown to medium tones of orangy-brown. A soft velvety appearance is commonly ascribed to fine topaz. TOURMALINE occurs in medium to dark tones of brown to reddish and orangy-brown. ZIRCON (HYACINTH) occurs in medium to dark tones of orange-yellow to reddish-brown. DOUBLETS imitating fine topaz are plentiful. Garnet-and-glass false doublets are used almost exclusively. TRIPLETS in a brown hue are all but unknown.

Gems Infrequently Encountered in the Jewelry Trade. SPES-SARTITE GARNET is similar in appearance to hessonite, but slightly more brilliant; it is much less common than hessonite. SPHENE is a rare gem occurring in a range of hues from yellowish to greenish brown, distinguished by fire greater than the diamond

and birefringence so strong that it is usually visible to the unaided eye.

Testing Procedure. It should be emphasized that it is not necessary to make all the tests indicated in identifying every stone. However, unless a gem is determined to be a doublet or triplet, or shows inclusions characteristic of a synthetic, a determination is rarely positive until tests have been carried through the refractive index reading.

First Test. Clean the stone and examine it with the unaided eye or low power loupe for any unusual property or appearance. In this preliminary examination, observation of any of the following properties may facilitate identification:

A red ring around the girdle when the gem is placed face down on white paper, or *a difference in luster along the crown facets*, indicates a garnet-and-glass false doublet.

High luster suggests diamond, sphene or zircon.

Strong dispersion (fire) suggests diamond, sphene or zircon. *Warmth to the touch* (compared to the cold feel of crystalline materials) suggests amber, glass, opal or plastics.

Double images of back facet edges are often visible in a large sphene or zircon, without the aid of magnification.

A visible separation plane indicates a doublet or a triplet.

An exceedingly low specific gravity is often noticeable in amber and substitutes such as bakelite and copal.

Second Test. Examine the gem under high magnification (30X to 60X or higher, if necessary).^{*} The magnification test often does more than distinguish between natural and man-made gems, since it makes possible the observation of the inclusions which often characterize a single natural gem species.

Characteristic inclusions of natural and synthetic brown and orange gemstones are described and illustrated in Chapter VIII. Angular inclusions characterize natural gems; spherical bubbles, or curved striae, prove artificial origin.

^{*}If not available, use a 10X or 20X loupe.

Identification of Transparent Brown, Orange Gemstones

Magnification often reveals double images of pavilion facet edges or of inclusions. In this event, the polariscope test is eliminated, hastening the final identification. If double images accompany the spherical bubbles that prove artificial origin, the unknown must be synthetic corundum, since synthetic corundum is the only man-made doubly refractive brown or orange gem.

Inclusions characteristic of a single gem species also identify an unknown at this point.

ANGULAR INCLUSIONS REVEALED UNDER HIGH MAGNIFICATION INDICATE THE FOLLOWING NATURAL, TRANSPARENT, BROWN OR ORANGE GEMSTONES:

Amber	Spessartite garnet*
Beryl	Sphene*
Chrysoberyl	Spinel
Copal and other natural resins	Topaz
Corundum (padparadsha)	Tourmaline
Diamond	Zircon (hyacinth)
Grossularite garnet (hessonite)	Doublets or triplets partially or wholly made of genuine materials.
Opal (fire opal)	
Quartz (carnelian)	
Chalcedony (carnelian)	

*Gems infrequently encountered in the jewelry trade.

TRANSPARENT BROWN OR ORANGE GEM MATERIALS CONTAINING INCLUSIONS CHARACTERISTIC OF ARTIFICIAL ORIGIN:

Glass	Doublets or triplets partially composed of glass or wholly genuine materials with bubbles in the joining plane.
Plastics	
Synthetic corundum	
Synthetic spinel	

Third Test. Immerse the gem in a liquid of intermediate to high refractive index to detect a doublet or triplet, or to re-examine it if no inclusions were discovered in the second test. (See Chapter VII). The presence of a separation plane across the gem may now identify it as a doublet or triplet, in which case no test, other than one to determine the nature of the portions of the assembled stone, need be made. Thus, doublets and triplets are either detected or eliminated by this test.

If it is difficult to resolve the gem's inclusions with an ordinary microscope, it may be because the gem is of high refractive index, therefore highly reflective, especially if the gem is brilliant-cut. In this event, or if no inclusions were visible on first examination under high magnification, immerse the gem in bromoform or methylene iodide to reduce reflections and improve the view of its interior. Re-examine it very carefully, but bear in mind that some gems are without identifying flaws under *any* feasible magnification.

Fourth Test. Examine the gem in the polariscope or under a polarizing microscope, to test it for single or double refraction. Double refraction may also be detected under magnification on the refractometer, with the dichroscope, or by the reflection test. Since it is not always apparent using the latter methods, failure to discover double refraction by methods other than those involving the polariscope or polarizing microscope is NOT proof of single refraction. Directions for use of the instruments for detection of single and double refraction are given in Chapter VI. (For optic character table, see Appendix.)

On the basis of one or more of the tests for single and double refraction and the previous tests, the gem can be assigned to one of the following groups:

1. DOUBLY REFRACTIVE, TRANSPARENT, NATURAL, BROWN OR ORANGE GEMS:

Beryl	Sphene*
Chrysoberyl	Topaz
Corundum (padparadsha)	Tourmaline
Quartz (cairngorm)	Zircon
Chalcedony (carnelian)	

2. SINGLY REFRACTIVE, TRANSPARENT, NATURAL, BROWN OR ORANGE GEMS:

Amber	Opal (fire opal)
Copal and other natural resins	Spessartite garnet*
Diamond	Spinel
Grossularite garnet (hessonite)	

*Gems infrequently encountered in the jewelry trade.

Identification of Transparent Brown, Orange Gemstones

3. DOUBLY REFRACTIVE, TRANSPARENT, ARTIFICIAL, BROWN OR ORANGE GEM MATERIAL:

Synthetic corundum

1. SINGLY REFRACTIVE, TRANSPARENT, ARTIFICIAL, BROWN OR ORANGE GEM MATERIALS:

Glass
Plastics

Synthetic spinel

Synthetic spinel almost invariably exhibits strong anomalous double refraction. The effect observed is a "cross-hatched" appearance in the dark (crossed Nicols) position of the polariscope or polarizing microscope (See Figure 84).

If the gem proves to be doubly refractive, TEST IT FOR PLEOCHROISM, using the dichroscope, polariscope or polarizing microscope. The following gems often display STRONG DICHROISM. Their characteristic dichroic colors follow:

Brown and yellow-green — tourmaline.

One image yellow-brown to orange, the other almost colorless
— corundum.

Characteristic dichroic colors of gems which display distinct dichroism follow:

Yellow-brown and yellow — topaz.

Purplish-brown and brownish-yellow — zircon.

WEAK DICHROISM is of little value in the identification of brown and orange stones, since most of the pale gems exhibit little or no color difference.

The following gems show DISTINCT TRICHROISM. Their trichroic colors are:

Brown, yellow and yellow-green — chrysoberyl.

Yellow-green, orange, and blue-green — sphene.

HANDBOOK OF GEM IDENTIFICATION

Now it has been established that the gem occurs in one of the four groups listed under the fourth test. In addition, characteristic inclusions, dichroism and luster may have proved useful as clues to the identity of the unknown gem. Usually the determination of refractive index will positively identify the gem at this point in the procedure.

Fifth Test. Examine the stone on a refractometer to determine the refractive index. Unless the refractometer reading is a value midway between the figures given for two gems in the tables that follow, a careful reading will leave no doubt as to the gem's identity. If no reading is obtained, or if the reading is inconclusive, an approximate index may be determined in some cases by means of the apparent depth method, or the approximate immersion method. If no index value is obtained, proceed to the next test.

PRINCIPAL INDICES OF NATURAL, DOUBLY REFRACTIVE, TRANSPARENT, BROWN OR ORANGE GEMSTONES:

Zircon (high, medium).....	1.925	to 1.984
Sphene*	1.900	to 2.034
Corundum (padparadsha)	1.762 (— .003, + .008)	to 1.770 (— .003, + .008)
Chrysoberyl	1.746 (± .004)	to 1.755 (± .005)
Tourmaline	1.624 (± .005)	to 1.644 (± .006)
Topaz	1.619 (± .012)	to 1.627 (± .012)
Beryl	1.577 (± .016)	to 1.583 (± .017)
Quartz (cainngorm).....	1.544 (± .00)	to 1.553 (± .00)
Chalcedony (carnelian)	1.535	to 1.539

If difficulty is encountered in distinguishing corundum from chrysoberyl by means of the difference in their refractive index readings, a specific gravity determination will separate the two gemstones.

Tourmaline is easily distinguished from topaz by the strong birefringence of the former, or by a specific gravity determination. Zircon and sphene are also separated by a specific gravity determination.

*Gems infrequently encountered in the jewelry trade.

Identification of Transparent Brown, Orange Gemstones

INDICES OF NATURAL, SINGLY REFRACTIVE, TRANSPARENT, BROWN OR ORANGE GEMSTONES:

Diamond	2.417
Spessartite garnet*	1.81
Grossularite garnet	1.745
Spinel	1.726 ($\pm .014$)
Amber	1.54
Copal	1.54
Opal	1.45 ($\pm .02$)

INDICES OF ARTIFICIAL, DOUBLY REFRACTIVE, TRANSPARENT, BROWN OR ORANGE GEM MATERIAL:

Synthetic corundum.....	1.76 to 1.77
-------------------------	--------------

INDICES OF ARTIFICIAL, SINGLY REFRACTIVE, TRANSPARENT, BROWN OR ORANGE GEM MATERIALS:

Glass (extreme range of gem imitation types).....	1.44-1.77
Glass (normal range)	1.48-1.70
Synthetic spinel.....	1.73 ($\pm .010$)
Plastics — Celluloid	1.49-1.52
Plexiglass and lucite.....	1.50
Bakelites	1.55-1.67
Polystyrene	1.59-1.67
(Maximum range for plastics 1.49-1.67)	

To distinguish between glass and plastics, a specific gravity test is necessary.

Sixth Test. Test the gem for specific gravity on the diamond balance, or with high-density liquids. It is rarely necessary to determine specific gravity, since the gem should have been identified by the time the refractive index reading has been made.

SPECIFIC GRAVITY OF NATURAL, DOUBLY REFRACTIVE, TRANSPARENT, BROWN OR ORANGE GEMSTONES:

Zircon (high, medium).....	4.70 ($\pm .03$)
Corundum (padparadsha)	4.00 ($\pm .05$)
Chrysoberyl	3.73 ($\pm .02$)
Topaz	3.53 ($\pm .04$)
Sphene*	3.52 ($\pm .02$)
Tourmaline	3.07 ($\pm .03$)
Beryl	2.72 ($-.05, +.12$)
Quartz (cainngorm)	2.66 ($\pm .01$)
Chalcedony (carnelian)	2.61 ($\pm .03$)

*Gems infrequently encountered in the jewelry trade.

HANDBOOK OF GEM IDENTIFICATION

Topaz and sphene are easily distinguished by the high birefringence of sphene. Beryl and quartz are distinguished by refractive index. (See Fifth Test.)

SPECIFIC GRAVITY OF NATURAL, SINGLY REFRACTIVE, TRANSPARENT, BROWN OR ORANGE GEMSTONES:

Spessartite garnet*	4.15 ($\pm .10$)
Grossularite garnet (hessonite).....	3.61 ($-.04, +.12$)
Spinel	3.60 ($-.03, +.10$)
Diamond	3.52 ($\pm .01$)
Opal	2.15 ($\pm .08$)
Amber	1.08 ($\pm .02$)
Copal	1.06

Copal is distinguished from amber by the use of ether which quickly softens copal but not amber.

SPECIFIC GRAVITY OF ARTIFICIAL, DOUBLY REFRACTIVE, TRANSPARENT, BROWN AND ORANGE GEM MATERIAL:

Synthetic corundum.....	4.00 ($\pm .05$)
-------------------------	--------------------

Since synthetic corundum is the only truly doubly refractive substitute for a natural brown or orange gem, determination of double refraction and characteristic inclusions visible under magnification would have eliminated it before this stage in the identification had been reached.

SPECIFIC GRAVITY OF ARTIFICIAL, SINGLY REFRACTIVE, TRANSPARENT, BROWN AND ORANGE GEM MATERIALS:

Glass	2.3 to 4.5
(Can be higher if high in lead oxide.)	

Synthetic spinel	3.60 ($\pm .15$)
------------------------	--------------------

Plastics less than 2.0—with rare exceptions they float in Carbona (density 1.59).

Bakelite floats in carbona, while glass sinks rapidly.

The specific gravity of glass can be the same as that of synthetic spinel, in which case the typical "cross-hatched" appear-

**Gems infrequently encountered in the jewelry trade.*

Identification of Transparent Brown, Orange Gemstones

ance due to anomalous double refraction in synthetic spinel will distinguish it (See illustration on page 113). Since neither is valuable, the hardness test can be used. Glass is easily scratched by a steel file, but synthetic spinel is not.

Seventh Test. Hardness should be used in the identification of transparent gems only as a last resort. If the gemologist has the necessary instruments to make a positive identification by the foregoing procedure, a hardness determination should never be made. (See hardness table, page 9).

HANDBOOK OF GEM IDENTIFICATION

Transparent Gems and Their Substitutes that Occur in a BROWN or ORANGE Color.				
First Test Initial Examination	Amber Beryl Chrysoberyl Coral Corundum Diamond Glass	Grossularite Opal (fire opal) Plastics Quartz (Cairngorm) Chalcedony	*Spessartite *Sphene Spinel Synthetic Corundum Synthetic Spinel	Topaz Tourmaline Zircon Doublets Triplets
Second Test Magnification to Determine Shape of Inclusions, etc.	Natural Gems			Man-Made
	Amber Beryl Chrysoberyl Copal Corundum Diamond	Grossularite Opal Quartz Chalcedony *Spessartite *Sphene	Spinel *Spinel Topaz Tourmaline Zircon Triplets Doublets	Glass Plastics Synthetic Corundum Synthetic Spinel Doublets Triplets
Third Test Immersion	Doublets or Triplets detected or eliminated.			
Fourth Test Single or Double Refraction Pleochroism	Natural Singly Refractive	Natural Doubly Refractive	Artificial Singly Refractive	Artificial Doubly Refractive
	Amber Copal Diamond Grossularite Opal *Spessartite Spinel	Beryl Chrysoberyl Corundum Quartz Chalcedony *Sphene Topaz Tourmaline Zircon	Glass Plastics Synthetic Spinel	Synthetic Corundum
Fifth Test Determination of Refractive Index	Diamond 2.417 *Spessartite 1.81 Grossularite 1.745 Spinel 1.726 Amber 1.54 Copal 1.54 Opal 1.45	Zircon 1.925-1.984 Sphene 1.900-2.034 Corundum 1.762-1.770 Chrysoberyl 1.746-1.755 Tourmaline 1.624-1.644 Topaz 1.619-1.627 Beryl 1.577-1.583 Quartz 1.544-1.553 Chalcedony 1.535-1.539	Glass, extreme 1.44-1.77 Glass, normal 1.48-1.70 Synthetic Spinel 1.73 Plastics— Celluloid 1.49-1.52 Bakelite 1.55-1.61 Plexiglass & Lucite 1.50 Polystyrene 1.59-1.67	Synthetic Corundum 1.76-1.77
Sixth Test Determination of Specific Gravity	*Spessartite 4.15 Grossularite 3.61 Spinel 3.60 Diamond 3.52 Opal 2.15 Amber 1.08 Copal 1.06	Zircon 4.70 Corundum 4.00 Chrysoberyl 3.73 Topaz 3.53 *Sphene 3.52 Tourmaline 3.07 Beryl 2.72 Quartz 2.66 Chalcedony 2.61	Glass 2.3-4.5 Synthetic Spinel 3.60 Plastics less than 2.0	Synthetic Corundum 4.00
Seventh Test Hardness	Do not use unless it is essential.			
<i>*Gems infrequently encountered in the jewelry trade.</i>				

Chapter XX

The Identification of Transparent Pink and Red Gemstones and Their Substitutes

TRANSPARENT GEMS and their substitutes that are found in a pink or red color:

Almandite garnet	Rhodolite garnet
Andalusite	Spinel
Bakelite (and other plastics)	Spodumene (kunzite)
Beryl (morganite)	Synthetic corundum
Chrysoberyl (alexandrite)	Synthetic spinel
Corundum	Topaz
(ruby and pink sapphire)	Tourmaline (rubellite and Bordeaux tourmaline)
Diamond	Zircon
Fluorite	Doublets
Glass	Triplets
Opal (fire opal)	Foil backs
Pyrope garnet	
Quartz (rose quartz)	
Chalcedony (carnelian and sard)	

Descriptions of Transparent Pink and Red Gemstones and their Substitutes. ALMANDITE GARNET occurs in dark to very dark tones of red to violetish-red with a sub-adamantine luster. ANDALUSITE of gem quality occurs in light to medium tones of brownish-red with greenish overtones. In this color, it changes from one hue under artificial light to a second hue in daylight. In daylight, the greenish overtones become more prominent. BAKELITE, a plastic, is manufactured in almost any color common to natural gems. BERYL (MORGANITE) is found in light to very light tones of red to red-violet. CHRYSOBERYL (ALEXAN-

DRITE) is a dark red similar to almandite garnet under artificial light and green in daylight. The color change is much more pronounced than in any other gem or substitute. CORUNDUM (RUBY) by definition of the term ruby is limited to stones of medium to slightly dark tones of intense red to violetish-red. To stones of light to very light tones of red the term *pink sapphire* is more properly applied. *Burma rubies* are usually a high intensity medium violetish-red; *Siam rubies* are normally dark red, and those from *Ceylon*, light red in tone. DIAMOND of a red color is the rarest of all gems, and is all but unknown. Very light red diamonds are seen occasionally. Their high luster and fire distinguish light red diamonds on sight. FLUORITE is found in light to medium tones of red to purple with a characteristic lack of brilliance. GLASS is manufactured in a wide range of tones and intensities of red. FIRE OPAL seldom shows opal's characteristic play of color. It is usually red-orange to brownish-orange, but occasionally is found in light to medium red. PYROPE GARNET is similar to almandite, but the color is slightly more intense. ROSE QUARTZ, a light to very light tone of red to red-violet, is usually cloudy. *Carnelian* is usually brownish-orange, but occasionally light to medium brownish-red. *Sard* is darker in tone than carnelian and less intense. RHODOLITE GARNET is lighter in tone than the other red garnets. It is light to medium violetish-red to red-violet of high intensity. SPINEL of a red hue is usually less intense in color and contains more orange than ruby, but dark red spinel similar to almandite garnet appears occasionally. Medium tones and intensities of orangy-red are not uncommon. SPODUMENE (KUNZITE) occurs in very light tones of red to reddish-violet. It is never deeply colored. SYNTHETIC CORUNDUM (SYNTHETIC RUBY) is manufactured in the same tones and intensities of color that occur in natural ruby, but the hue, normally violetish-red in the natural, is orangy-red in the synthetic. Synthetic corundum with an alexandrite-like change in color is sold as "synthetic alexandrite." The color change is less marked than in the case of natural alexandrite and the color in daylight is more grayish-blue than green. SYNTHETIC SPINEL is made in a

Identification of Transparent Pink, Red Gemstones

variety of colors, but the red is usually light in tone — resembling kunzite or morganite. TOPAZ is always light to very light in tone when found in a red color. TOURMALINE (RUBELLITE), the pink or red variety of the species, is usually light to medium in tone. It is often visibly fractured. Dark red-violet gems are sometimes called *Bordeaux tourmaline*, because of the color resemblance to Bordeaux wine. Truly red ZIRCON is exceedingly rare, but the *hyacinth* variety is often red-orange. Deep red-brown zircon is not uncommon. RED DOUBLETS are usually red glass, topped with almandite garnet, but ruby and glass, and ruby and ruby are not unknown. The color range is wide. RED TRIPPLETS are almost unknown in the jewelry trade. STAR QUARTZ FOIL BACKS backed by a red mirror to simulate star ruby are frequently encountered in the trade. Faceted natural stones are rarely backed by red foil.

Testing Procedure. CAUTION: So many transparent gems occur in a red color that tests must be made carefully. One careless test may lead to an incorrect conclusion regarding the identity of the material.

It should be emphasized that it is not necessary to make all the tests indicated in identifying every stone. However, unless a gem is determined to be a doublet, triplet or foil back, or shows inclusions characteristic of a synthetic, a determination is rarely positive until tests have been carried though the refractive index reading.

First Test. Clean the stone and examine it with the unaided eye or a low power loupe for any unusual property or appearance. In this preliminary examination, observation of any of the following properties may facilitate identification:

Distinct color change from daylight to artificial light may indicate chrysoberyl (alexandrite), synthetic alexandrite-like corundum or andalusite.

Adamantine luster suggests diamond.

Unusually dull luster suggests fluorite.

Strong dispersion suggests diamond or zircon.

Warmth to the touch (compared to the cold feel of crystalline materials) is a property of amorphous materials such as opal and glass and plastic imitations.

An exceedingly low specific gravity is often noticeable in plastic imitations, when a large stone is lifted.

Double images of back facet edges are often visible in a large zircon, without aid of magnification.

A color difference between crown and pavilion suggests a doublet or triplet.

A visible separation plane indicates a doublet or a triplet.

A coated back on a star stone proves a star foil back.

A luster difference between crown and pavilion or between table and the lower crown facets suggests a doublet.

Molded back facets prove the unknown to be a glass or plastic imitation. (See Chapter XI).

Second Test. Examine the gem under high magnification (30X to 60X or higher, if necessary).^{*}The magnification test often does more than distinguish between natural and man-made gems, since it makes possible the observation of the inclusions which often characterize a single natural gem species.

Characteristic inclusions of natural and synthetic red gemstones are described and illustrated in Chapter VIII. Angular inclusions characterize natural red gems; spherical bubbles, or curved striae, prove artificial origin.

Magnification often reveals double images of pavilion facet edges or of inclusions. In this event, the polariscope test is eliminated, hastening the final identification. If double images accompany the spherical bubbles that prove artificial origin, the unknown must be synthetic corundum, since synthetic corundum is the only man-made doubly refractive pink or red gem.

Inclusions characteristic of a single gem species also identify an unknown at this point.

^{*}If not available, use a 10X or 20X loupe.

Identification of Transparent Pink, Red Gemstones

ANGULAR INCLUSIONS REVEALED UNDER HIGH MAGNIFICATION INDICATE THE FOLLOWING NATURAL, TRANSPARENT, RED OR PINK GEMSTONES:

Almandine garnet	Rhodolite garnet
Andalusite	Spinel
Beryl (morganite)	Spodumene (kunzite)
Chrysoberyl (alexandrite)	Topaz
Corundum	Tourmaline (rubellite and Bourdeaux tourmaline)
(ruby and pink sapphire)	Zircon
Diamond	Doublets, triplets and foil backs partially or wholly made of genuine materials.
Fluorite	
Opal	
Pyrope garnet	
Quartz (rose quartz)	
Chalcedony (carnelian and sard)	

TRANSPARENT RED OR PINK GEM MATERIALS CONTAINING INCLUSIONS CHARACTERISTIC OF ARTIFICIAL ORIGIN:

Bakelite or other plastics	Doublets or triplets partially composed of glass or wholly genuine materials with bubbles in the joining plane.
Glass	
Synthetic corundum	
Synthetic spinel	

Third Test. Immerse the gem in a liquid of intermediate to high refractive index to detect a doublet or triplet, or to re-examine it if no inclusions were discovered in the second test. (See Chapter VII).

If it is difficult to resolve the gem's inclusions with an ordinary microscope, it may be because the gem is of high refractive index, therefore highly reflective, especially if the gem is brilliant-cut. In this event, or if no inclusions were visible on first examination under high magnification, immerse the gem in bromoform or methylene iodide to reduce reflections and improve the view of its interior. Re-examine it very carefully, but bear in mind that some gems are without identifying flaws under *any* feasible magnification.

The presence of a separation plane across the gem may now identify it as a doublet or triplet, in which case no test, other than one to determine the nature of the portions of the assem-

bled stone, need be made. Thus, doublets and triplets are either detected or eliminated by this test.

Fourth Test. Examine the gem in the polariscope or under a polarizing microscope, to test it for single or double refraction. Double refraction may also be detected under magnification, on the refractometer, with the dichroscope or by the reflection test. Since it is not always apparent using the latter methods, failure to discover double refraction by methods other than those involving the polariscope or polarizing microscope is NOT proof of single refraction. Directions for use of the instruments for detection of single and double refraction are given in Chapter VI. (For optic character table, see Appendix.)

On the basis of one or more of the tests for single and double refraction and the previous tests, the gem can be assigned to one of the following groups:

1. DOUBLY REFRACTIVE, TRANSPARENT, NATURAL RED OR PINK
GEMS:

Andalusite	Chalcedony (carnelian and sard)
Beryl (morganite)	Spodumene (kunzite)
Chrysoberyl (alexandrite)	Topaz
Corundum (ruby or pink sapphire)	Tourmaline (rubellite and Bordeaux tourmaline)
Quartz (rose quartz)	Zircon

2. SINGLY REFRACTIVE, TRANSPARENT, NATURAL RED OR PINK
GEMS:

Almandite garnet	Pyrope garnet
Diamond	Rhodolite garnet
Fluorite	Spinel
Opal	

3. DOUBLY REFRACTIVE, TRANSPARENT, ARTIFICIAL RED OR PINK
GEM MATERIAL:

Synthetic corundum

Identification of Transparent Pink, Red Gemstones

4. SINGLY REFRACTIVE, TRANSPARENT, ARTIFICIAL RED OR PINK GEM MATERIALS:

Glass

Plastics

Synthetic spinel

Synthetic spinel almost invariably exhibits strong anomalous double refraction. The effect observed is a "cross-hatched" appearance in the dark (crossed Nicols) position of the polarizer or polarizing microscope (See Figure 84).

If the gem proves to be doubly refractive, TEST IT FOR PLEOCHROISM, using the dichroscope, polariscope or polarizing microscope. The following gems often display STRONG DICHROISM. Their characteristic dichroic colors follow:

Dark red and brown — andalusite.

Dark red and light red — tourmaline (rubellite).

One image light red to light purple; the other, colorless —
spodumene (kunzite).

Light red and yellow — topaz (often too pale in color to be visibly dichroic).

Violetish-red and orangy-red — corundum (ruby).

Reddish-purple and reddish-brown — zircon.

WEAK DICHROISM is of little value in the identification of red stones, since most of the pale gems exhibit little or no color difference.

The only red or pink gem which shows STRONG TRICHROISM is the *alexandrite variety of chrysoberyl*. Its trichroic colors are *dark red, orange and dark green*.

Red garnets often exhibit strong anomalous double refraction that is difficult to distinguish from true double refraction (See Chapter VI). All doubly refractive dark red gemstones are strongly pleochroic. Hence, failure to observe pleochroism when examining a dark red transparent gem with a dichroscope in three or more directions may be safely interpreted as proof that the gem is singly refractive.

Now it has been established that the gem occurs in one of the four groups listed under the fourth test. In addition, characteristic inclusions, dichroism, and luster may have proved useful as clues to the identity of the unknown gem. Usually the determination of refractive index will positively identify the gem at this point in the procedure.

Fifth Test. Mount the stone on a refractometer to determine the refractive index. Unless the refractometer reading is a value midway between the figures given for two gems in the tables that follow, a careful reading will leave no doubt as to the gem's identity. If no reading is obtained, or if the reading is inconclusive, an approximate index may be determined in some cases by means of the apparent depth method, or the approximate immersion method. If no index value is obtained, proceed to the next test.

PRINCIPLE INDICES OF NATURAL, DOUBLY REFRACTIVE, TRANSPARENT, RED OR PINK GEMSTONES:

Zircon (high, medium).....	1.925	to 1.984
Corundum (ruby and pink sapphire)	1.762 (— .003, + .008)	to 1.770 (— .003, + .008)
Chrysoberyl (alexandrite)	1.746 (± .004)	to 1.755 (± .005)
Spodumene (kunzite)	1.660 (± .005)	to 1.676 (± .005)
Andalusite	1.634	to 1.643
Tourmaline (rubellite and Bordeaux tourmaline)	1.624 (± .005)	to 1.644 (± .006)
Topaz	1.619 (± .012)	to 1.627 (± .012)
Beryl (morganite).....	1.585 (± .004)	to 1.593 (± .004)
Quartz (rose quartz).....	1.544 (± .00)	to 1.553 (± .00)
Chalcedony (carnelian and sard).....	1.535	to 1.539

If difficulty is encountered in distinguishing corundum from chrysoberyl by means of the difference in the refractive index readings, a specific gravity determination will separate the two gemstones. Tourmaline is easily distinguished from andalusite and topaz by its strong birefringence. A specific gravity test will separate andalusite and topaz.

Identification of Transparent Pink, Red Gemstones

INDICES OF NATURAL, SINGLY REFRACTIVE, TRANSPARENT, RED OR PINK GEMSTONES:

Diamond	2.417
Almandite garnet	1.79 ($\pm .02$)
Rhodolite garnet	1.76 ($\pm .02$)
Pyrope garnet	1.746 ($-.016, +.010$)
Spinel	1.726 ($\pm .014$)
Opal	1.45 ($\pm .02$)
Fluorite	1.434 ($\pm .00$)

INDICES OF ARTIFICIAL, DOUBLY REFRACTIVE, TRANSPARENT, RED OR PINK GEM MATERIAL:

Synthetic corundum	1.76 to 1.77
--------------------------	--------------

INDICES OF ARTIFICIAL, SINGLY REFRACTIVE, TRANSPARENT, RED OR PINK GEM MATERIALS:

Glass (extreme range of gem imitation types).....	1.44-1.77
Glass (normal range).....	1.48-1.70
Synthetic spinel	1.73 ($\pm .010$)
Plastics — Celluloid	1.49-1.52
Plexiglass and lucite.....	1.50
Bakelite	1.55-1.67
Polystyrene	1.59-1.67

(Maximum range for plastics 1.49-1.67)

Sixth Test. Test the gem for specific gravity on the diamond balance, or with high-density liquids. It is rarely necessary to determine specific gravity, since the gem should have been identified by the time the refractive index reading has been made.

SPECIFIC GRAVITY OF NATURAL, DOUBLY REFRACTIVE, TRANSPARENT, RED OR PINK GEMSTONES:

Zircon (high, medium).....	4.70 ($\pm .03$)
Corundum (ruby and pink sapphire).....	4.00 ($\pm .05$)
Chrysoberyl (alexandrite).....	3.73 ($\pm .02$)
Topaz	3.53 ($\pm .04$)
Spodumene (kunzite)	3.18 ($\pm .03$)
Andalusite	3.17 ($\pm .04$)
Tourmaline (rubellite and Bordeaux tourmaline).....	3.04 ($\pm .03$)
Beryl (morganite)	2.82 ($\pm .05$)
Quartz (rose quartz).....	2.66 ($\pm .01$)
Chalcedony (carnelian and sard)	2.61 ($\pm .03$)

HANDBOOK OF GEM IDENTIFICATION

Beryl and quartz of a red color are readily distinguished by the test for specific gravity, but should have been determined by their usually sharp refractive readings.

The close agreement in specific gravity of andalusite and spodumene should not cause confusion, since dichroism, or a refractive index reading should have separated them before reaching this stage in the testing procedure.

SPECIFIC GRAVITY OF NATURAL, SINGLY REFRACTIVE, TRANSPARENT, RED AND PINK GEMSTONES:

Almandite garnet	4.05 ($\pm .12$)
Rhodolite garnet.....	3.84 ($\pm .12$)
Pyrope garnet.....	3.78 ($\pm .09$)
Spinel	3.60 ($-.03, +.10$)
Diamond	3.52 ($\pm .01$)
Fluorite	3.18 ($\pm .01$)
Opal	2.15 ($\pm .08$)

The specific gravity range in this group is sufficiently great so that a careful determination will give the correct identification, and eliminate the necessity for further tests.

SPECIFIC GRAVITY OF ARTIFICIAL, DOUBLY REFRACTIVE, TRANSPARENT, RED AND PINK GEM MATERIAL:

Synthetic corundum.....	4.00 ($\pm .03$)
-------------------------	--------------------

Since synthetic corundum is the only truly doubly refractive substitute for a natural red or pink gem, determination of double refraction and characteristic inclusions visible under magnification would have eliminated it before this stage in the identification had been reached.

Identification of Transparent Pink, Red Gemstones

SPECIFIC GRAVITY OF ARTIFICIAL, SINGLY REFRACTIVE, TRANSPARENT, RED AND PINK GEM MATERIALS:

Glass	2.3 to 4.2
Synthetic spinel.....	3.60 ($\pm .15$)
Plastics less than 2.0—with rare exceptions they float in Carbona (density 1.59).	

The specific gravity of glass can be the same as that of synthetic spinel, in which case the typical "cross-hatched" appearance due to anomalous double refraction in synthetic spinel will distinguish it (see illustration on Page 113). Since neither is valuable, the hardness test can be used. Glass is easily scratched by a steel file, but synthetic spinel is not.

Seventh Test. Hardness should be used in the identification of transparent gems only as a last resort. If the gemologist has the necessary instruments to make a positive identification by the foregoing procedure, a hardness determination should never be made. (See hardness table, Page 9).

HANDBOOK OF GEM IDENTIFICATION

Transparent Gems and Their Substitutes that Occur in a RED or PINK Color.				
First Test Initial Examination	Almandite Andalusite Beryl Chrysoberyl Corundum Diamond Fluorite	Glass Opal Plastics Pyrope Quartz Chalcedony Rhodolite	Spinel Spodumene Synthetic Corundum Synthetic Spinel Topaz	Tourmaline Zircon Triplets Doublets Foilbacks
Second Test Magnification to Determine Shape of Inclusions, Etc.	Natural Gems			Man-Made
	Almandite Andalusite Beryl Chrysoberyl Corundum Diamond Fluorite Opal	Pyrope Quartz Rhodolite Spodumene Spinel Topaz Tourmaline Zircon	Doublets Triplets Foilbacks	Glass Plastics Synthetic Corundum Synthetic Spinel Doublets Triplets Foilbacks
Third Test Immersion	Doublets or Triplets detected or eliminated.			
Fourth Test Single or Double Refraction, Pleochroism	Artificial Doubly Refractive	Natural Doubly Refractive	Artificial Singly Refractive	Artificial Doubly Refractive
	Almandite Diamond Fluorite Opal Pyrope Rhodolite Spinel	Andalusite Beryl Chrysoberyl Corundum Quartz Spodumene Topaz Tourmaline Zircon	Glass Synthetic spinel Plastics	Synthetic Corundum
Fifth Test Determination of Refractive Index	Diamond 2.417 Almandite 1.79 Rhodolite 1.76 Pyrope 1.746 Spinel 1.726 Opal 1.45 Fluorite 1.434	Zircon 1.925-1.984 Corundum 1.762-1.770 Chrysoberyl 1.746-1.755 Spodumene 1.660-1.676 Andalusite 1.634-1.643 Tourmaline 1.624-1.644 Topaz 1.619-1.627 Beryl 1.585-1.593 Quartz 1.544-1.553 Chalcedony 1.535-1.539	Glass, extreme range 1.44-1.77 Glass, normal 1.48-1.70 Synthetic Spinel 1.73 Plastics 1.49-1.67	Synthetic Corundum 1.76-1.77
Sixth Test Determination of Specific Gravity	Almandite 4.05 Rhodolite 3.84 Pyrope 3.78 Spinel 3.60 Diamond 3.52 Fluorite 3.18 Opal 2.15	Zircon 4.70 Corundum 4.00 Chrysoberyl 3.73 Topaz 3.53 Spodumene 3.18 Andalusite 3.17 Tourmaline 3.04 Beryl 2.82 Quartz 2.66 Chalcedony 2.61	Glass 2.3-4.5 Synthetic Spinel 3.60 Plastics less than 2.0	Synthetic Corundum 4.00
Seventh Test Hardness	Do not use unless it is essential.			
<i>*Gems infrequently encountered in the jewelry trade.</i>				

Chapter XXI

The Identification of Transparent Colorless Gemstones and Their Substitutes

Transparent colorless gems and their substitutes include the following:

Beryl	Quartz (rock crystal)
Corundum (white sapphire)	Chalcedony moonstone
Diamond	Spinel
Glass	Synthetic corundum
Opal	Synthetic spinel
Orthoclase feldspar (moonstone)	Topaz
Plastics	Tourmaline
	Zircon (jargoon)

Gems and gem substitutes infrequently encountered in the jewelry trade:

Beryllonite	Spodumene
Euclase	Doublets
Phenacite	

Descriptions of Transparent Colorless Gemstones and their Substitutes: **BERYL** (GOSHENITE) occurs in a colorless form and in very light tones of red, blue, green and yellow. It has a vitreous luster and little brilliancy. **CORUNDUM** (WHITE SAPPHIRE) without color is a common gem. It is not easily confused with diamond or zircon because it lacks brilliancy and fire. **DIAMOND** is distinguished from other colorless gems by its strong dispersion and brilliancy. **GLASS** is made in a colorless transparent form to imitate diamond. **OPAL**, which is often nearly

transparent, is characterized by a play of color. ORTHOCLASE FELDSPAR (MOONSTONE), which is often nearly transparent, is characterized by a moving blue light reflected from it. Clear orthoclase is occasionally cut as a gem. The only PLASTICS which are common in a transparent form are lucite and plexiglass. QUARTZ (ROCK CRYSTAL) has low luster and weak dispersion. CHALCEDONY MOONSTONE lacks the blue sheen of precious moonstone and is less transparent. SPINEL occurs in a colorless form and in very light tones of red, blue and orange hues. SYNTHETIC CORUNDUM is made in transparent colorless boules. SYNTHETIC SPINEL is manufactured in transparent colorless form to imitate diamond. TOPAZ without hue is commonly used as a gem. TOURMALINE in a colorless form is not common in the trade. It is without distinguishing features to the unaided eye. ZIRCON (JARGON) is common in a colorless form. It is distinguished by strong dispersion and birefringence.

Gems and gem substitutes infrequently encountered in the jewelry trade.

BERYLLONITE in a colorless form resembles beryl and quartz. EUCLASE occurs in a colorless form resembling topaz and in very light tones of blue and green. It lacks distinguishing features to the unaided eye. PHENACITE lacks distinguishing features when it is colorless. SPODUMENE is rarely cut as a gem when it is without hue. DOUBLETS are not common in a colorless form.

Testing Procedure. It should be emphasized that it is not necessary to make all the tests indicated in identifying every stone. However, unless a gem is determined to be a doublet or triplet or shows inclusions characteristic of a synthetic, a determination is rarely positive until tests have been carried through the refractive index reading.

First Test. Clean the stone and examine it with the unaided eye or a low power loupe for any unusual property or appear-

Identification of Transparent Colorless Gemstones

ance. In this preliminary examination, observation of any of the following properties may facilitate identification:

Strong dispersion suggests diamond or zircon.

Doubling of back facet edges suggests zircon or tourmaline.

Play of color suggests opal.

Blue sheen in reflected light suggests precious moonstone (orthoclase feldspar).

Adamantine luster suggests diamond or zircon.

Second Test. Examine the gem under high magnification (30X to 60X or higher, if necessary).^{*} The magnification test often does more than distinguish between natural and man-made gems, since it makes possible the observation of the inclusions which often characterize a single natural gem species.

Characteristic inclusions of natural and synthetic colorless gemstones are described and illustrated in Chapter VIII. Angular inclusions characterize natural colorless gems; spherical bubbles, or curved striae, prove artificial origin.

Magnification often reveals double images of pavilion facet edges or of inclusions. In this event, the polariscope test is eliminated, hastening the final identification. If double images accompany the spherical bubbles that prove artificial origin, the unknown must be synthetic corundum, since synthetic corundum is the only man-made doubly refractive colorless gem.

ANGULAR INCLUSIONS REVEALED UNDER HIGH MAGNIFICATION INDICATE THE FOLLOWING NATURAL, TRANSPARENT, COLORLESS GEMSTONES:

Beryl	Quartz (rock crystal)
Corundum	Chalcedony moonstone
Diamond	Spinel
Opal	Topaz
Orthoclase feldspar (moonstone)	Tourmaline
	Zircon (jargoon)

Gems infrequently encountered in the jewelry trade.

Beryllonite	Doublets and triplets partially or wholly made of genuine materials.
Euclase	
Phenacite	
Spodumene	

^{*}If not available, use a 10X or 20X loupe.

TRANSPARENT, COLORLESS GEM MATERIALS CONTAINING INCLUSIONS CHARACTERISTIC OF ARTIFICIAL ORIGIN:

Glass	Doublets or triplets partially composed of glass or wholly genuine materials with bubbles in the joining plane.
Plastics	
Synthetic corundum	
Synthetic spinel	

Third Test. Immerse the gem in a liquid of intermediate to high refractive index to detect a doublet, or to re-examine it if no inclusions were discovered in the second test. (See Chapter VII). The presence of a separation plane across the gem may now identify it as a doublet, in which case no further test, other than one to determine the nature of the portions of the assembled stone, need be made. Thus, doublets are either detected or eliminated by this test.

If it is difficult to resolve the gem's inclusions with an ordinary microscope, it may be because the gem is of high refractive index, therefore highly reflective, especially if the gem is brilliant-cut. In this event, or if no inclusions were visible on first examination under high magnification, immerse the gem in bromoform or methylene iodide to reduce reflections and improve the view of its interior. Re-examine it very carefully, but bear in mind that some gems are without identifying flaws under *any* feasible magnification.

Fourth Test. Examine the gem in the polariscope or under a polarizing microscope, to test it for single or double refraction. Double refraction may also be detected under magnification, on the refractometer, with the dichroscope, or by the reflection test. Since it is not always apparent using the latter methods, failure to discover double refraction by methods other than those involving the polariscope or polarizing microscope is NOT proof of single refraction. Directions for use of the instruments for detection of single and double refraction are given in Chapter VI. (For optic character table, see Appendix.)

On the basis of one or more of the tests for single and double

Identification of Transparent Colorless Gemstones

refraction and the previous tests, the gem can be assigned to one of the following groups:

1. DOUBLY REFRACTIVE, TRANSPARENT, NATURAL COLORLESS GEMS:

Beryl	Topaz
Corundum (white sapphire)	Tourmaline
Orthoclase feldspar (moonstone)	Zircon (jargon)
Quartz (rock crystal)	
Chalcedony moonstone	

Gems infrequently encountered in the jewelry trade:

Beryllonite	Phenacite
Euclase	Spodumene

2. SINGLY REFRACTIVE, TRANSPARENT, NATURAL, COLORLESS GEMS:

Diamond	Spinel
Opal	

3. DOUBLY REFRACTIVE, TRANSPARENT, ARTIFICIAL, COLORLESS GEM MATERIAL:

Synthetic corundum

4. SINGLY REFRACTIVE, TRANSPARENT, ARTIFICIAL, COLORLESS GEM MATERIALS:

Glass	Synthetic spinel
Plastics	

Synthetic spinel almost invariably exhibits strong anomalous double refraction. The effect observed is a "cross-hatched" appearance in the dark (crossed Nicols) position of the polariscope or polarizing microscope. (See Figure 84).

Pleochroism will be of no value in the determination of the identity of a colorless gem.

Now it has been established that the gem occurs in one of the four groups listed under the fourth test. In addition, characteristic inclusions, optic character and luster may have proved use-

HANDBOOK OF GEM IDENTIFICATION

ful as clues to the identity of the unknown gem. Usually the determination of refractive index will positively identify the gem at this point in the procedure.

Fifth Test. Place the stone on a refractometer to determine the refractive index. If the gem is doubly refractive, it is often possible to determine optic character. Unless the refractometer reading is a value midway between the figures given for two gems in the tables that follow, a careful reading will leave no doubt as to the gem's identity. If no reading is obtained, or if the reading is inconclusive, an approximate index can be determined in some cases by means of the apparent depth method, or the approximate immersion method. If no index value is obtained, proceed to the next test.

INDICES OF NATURAL, DOUBLY REFRACTIVE, TRANSPARENT, COLORLESS GEMSTONES:

Zircon (high, medium)....	1.925	to 1.984
Corundum		
(white sapphire).....	1.762 (— .003, + .008)	to 1.770 (— .003, + .008)
Spodumene*	1.660	to 1.676
Phenacite *	1.654	to 1.670
Euclase *	1.651	to 1.670
Tourmaline	1.624 (± .005)	to 1.644 (± .006)
Topaz	1.619 (± .012)	to 1.627 (± .012)
Beryl	1.577 (± .016)	to 1.583 (± .017)
Beryllonite*	1.552	to 1.562
Quartz (rock crystal)	1.544 (± .00)	to 1.553 (± .00)
Chalcedony moonstone..	1.535	to 1.539
Orthoclase feldspar		
(moonstone)	1.518	to 1.526

**Gems infrequently encountered in the jewelry trade.*

The important gemstones are easily separated by this test. Tourmaline is distinguished from topaz by its strong double refraction or by a specific gravity test.

INDICES OF NATURAL, SINGLY REFRACTIVE, TRANSPARENT, COLORLESS GEMSTONES:

Diamond	2.417
Spinel	1.726 (± .014)
Opal	1.45 (± .02)

Identification of Transparent Colorless Gemstones

The only artificial doubly refractive, transparent, colorless gemstone not previously identified, synthetic corundum, was probably eliminated or identified in test four; however, the indices of this material are listed below.

INDICES OF ARTIFICIAL, DOUBLY REFRACTIVE, TRANSPARENT, COLORLESS GEM MATERIAL:

Synthetic corundum 1.762 ($\pm .002$) to 1.770 ($\pm .002$)

INDICES OF ARTIFICIAL, SINGLY REFRACTIVE, TRANSPARENT, COLORLESS GEM MATERIALS:

Glass (extreme range of gem imitation types)..... 1.44-1.77
Glass (normal range) 1.48-1.70
Synthetic spinel 1.73 ($\pm .010$)
Plastics — plexiglass and lucite 1.50

Sixth Test. Test the gem for specific gravity on the diamond balance, or with high-density liquids. It is rarely necessary to determine specific gravity, since the gem should have been identified by the time the refractive index reading has been made.

SPECIFIC GRAVITY OF NATURAL, DOUBLY REFRACTIVE, TRANSPARENT, COLORLESS GEMSTONES:

Zircon (high, medium)..... 4.70 ($\pm .03$)
Corundum (white sapphire)..... 4.00 ($\pm .05$)
Topaz 3.53 ($\pm .04$)
Spodumene* 3.18 ($\pm .03$)
Euclase* 3.10 ($\pm .01$)
Tourmaline 3.04 ($\pm .03$)
Phenacite* 2.95 ($\pm .01$)
Beryllonite* 2.85 ($\pm .02$)
Beryl 2.72 ($-.05, +.12$)
Quartz (rock crystal)..... 2.66 ($\pm .01$)
Chalcedony moonstone 2.61 ($\pm .03$)
Orthoclase feldspar (moonstone)..... 2.56 ($\pm .01$)

**Gems infrequently encountered in the jewelry trade.*

With the exception of spodumene, tourmaline and euclase, all natural, doubly refractive colorless gems can be separated by the specific gravity test. An accurate specific gravity determination

HANDBOOK OF GEM IDENTIFICATION

will separate spodumene from euclase. Tourmaline is distinguished from the other two by a refractive index reading, or by the determination of optic character.

SPECIFIC GRAVITY OF NATURAL, SINGLY REFRACTIVE, TRANSPARENT, COLORLESS GEMSTONES:

Spinel	3.60 (— .03, + .10)
Diamond	3.52 (± .01)
Opal	2.15 (± .08)

The specific gravity range in this group is sufficiently great so that a careful determination will give the correct identification, and eliminate the necessity for further tests.

SPECIFIC GRAVITY OF ARTIFICIAL, DOUBLY REFRACTIVE, TRANSPARENT, COLORLESS GEM MATERIAL:

Synthetic corundum.....	4.00 (± .03)
-------------------------	--------------

Since synthetic corundum is the only truly doubly refractive substitute for a natural colorless gem, determination of double refraction and characteristic inclusions visible under magnification would have eliminated it before this stage in the identification had been reached.

SPECIFIC GRAVITY OF ARTIFICIAL, SINGLY REFRACTIVE, TRANSPARENT, COLORLESS GEM MATERIALS:

Glass	2.3 to 4.5
Synthetic spinel.....	3.60 (± .16)
Plastics	1.18 to 1.55

The specific gravity of glass can be the same as that of synthetic spinel, in which case the typical "cross-hatched" appearance due to anomalous double refraction in synthetic spinel will distinguish it (see illustration on page 113). Since neither is valuable, the hardness test can be used. Glass is easily scratched by a steel file, but synthetic spinel is not.

Identification of Transparent Colorless Gemstones

Seventh Test. Hardness should be used in the identification of transparent gems only as a last resort. If the gemologist has the necessary instruments to make a positive identification by the foregoing procedure, a hardness determination should never be made. (See hardness table, page 9.)

HANDBOOK OF GEM IDENTIFICATION

Transparent COLORLESS Gems and Their Substitutes.				
First Test Initial Examination	Beryl *Beryllonite Corundum Diamond *Euclase Glass	Opal ‡Orthoclase ‡Phenacite Quartz (rock crystal) Chalcedony	Plastics Spinel Spodumene Synthetic Corundum	Synthetic Spinel Topaz Tourmaline Zircon *Doublets *Triplets
	Natural Gems			Man-Made
Second Test Magnification to Shape of Inclusions, Etc.	Beryl Corundum Diamond Opal ‡Orthoclase Feldspar	Spinel Quartz Chalcedony Topaz Tourmaline Zircon	*Beryllonite *Euclase *Phenacite *Spodumene Doublets Triplets	Glass Plastics Synthetic Corundum Synthetic spinel Doublets Triplets
Third Test Immersion	Doublets or Triplets detected or eliminated.			
	Natural Singly Refractive	Natural Doubly Refractive	Artificial Singly Refractive	Artificial Doubly Refractive
Fourth Test Single or Double Refraction, Pleochroism	Diamond Opal Spinel	Beryl Corundum ‡Orthoclase Quartz Topaz Tourmaline Zircon *Beryllonite *Phenacite *Euclase ‡Spodumene	Glass Plastics Synthetic spinel	Synthetic Corundum
Fifth Test Determination of Refractive Index	Diamond 2.41 Spinel 1.726 Opal 1.45	Zircon 1.925-1.984 Corundum 1.762-1.770 *Spodumene 1.660-1.676 *Phenacite 1.654-1.670 *Euclase 1.651-1.670 Tourmaline 1.624-1.644 Topaz 1.619-1.627 Beryl 1.577-1.583 *Beryllonite 1.552-1.562 Quartz 1.544-1.553 Chalcedony 1.535-1.539 Orthoclase 1.518-1.526	Glass, extreme 1.44-1.77 Glass, normal 1.48-1.70 Synthetic Spinel 1.73 Plastics--- Lucite 1.50 Plexiglass 1.50	Synthetic Corundum 1.762-1.770
Sixth Test Determination of Specific Gravity	Spinel 3.60 Diamond 3.52 Opal 2.15	Zircon 4.70 Corundum 4.00 Topaz 3.53 *Spodumene 3.18 *Euclase 3.10 Tourmaline 3.04 *Phenacite 2.95 *Beryllonite 2.85 Beryl 2.72 Quartz 2.66 Chalcedony 2.61 ‡Orthoclase 2.56	Glass 2.3-4.7 Synthetic Spinel 3.60 Plastics 1.18-1.55	Synthetic Corundum 4.00
Seventh Test Hardness	Do not use unless it is essential.			
<i>*Gems infrequently encountered in the jewelry trade.</i>				‡Moonstone

Chapter XXII

The Identification of Nontransparent Blue and Green Gemstones and Their Substitutes

NONTRANSPARENT GEMSTONES AND THEIR SUBSTITUTES WHICH
OCCUR IN A BLUE COLOR.

Azurite	Opal (black opal)
Chalcedonic quartz (chrysocolla quartz and dyed chalcedony)	Plastics
Corundum (star sapphire)	Quartz (cat's-eye quartz)
Glass	Turquoise
Labradorite feldspar	Variscite
Lazulite	Doublets
Lazurite (lapis lazuli)	Foil backs

NONTRANSPARENT GEMSTONES AND THEIR SUBSTITUTES WHICH
OCCUR IN A GREEN COLOR ARE:

Chalcedonic quartz (chrysoprase or bloodstone and dyed chal- cedony)	Labradorite feldspar
Chrysoberyl (cat's-eye)	Malachite
Glass	Microcline feldspar (amazonite)
Grossularite garnet	Nephrite jade
Idocrase	Opal (black opal)
Jadeite jade	Quartz (aventurine)
	Serpentine

Descriptions of Nontransparent Blue and Green Gemstones and Their Substitutes. AZURITE occurs only in a dark violetish-blue color. It is usually found intergrown with malachite (green). CHALCEDONIC QUARTZ occurs in nature in medium tones of both blue and green hues, and white or gray chalcedony is also dyed to imitate the natural ma-

terial. The translucent natural green chalcedony is called **CHRY-SOPRASE**. A lovely light blue of high intensity is imparted to chalcedony by chrysocolla, a copper mineral. Gem qualities are usually translucent. The **BLOODSTONE** variety of chalcedony is characterized by brownish-red spots in a semitranslucent dark bluish-green background. **CHRYSOBERYL (CAT'S-EYE)** is usually found in medium tones of greenish-yellow to yellowish-green hues characterized by a silky luster with a chatoyant effect observed on stones cut en cabochon. **CORUNDUM (STAR SAPPHIRE)** occurs in very light to very dark tones of blue to bluish-gray. Green star sapphires are rare. **GLASS** is made to imitate turquoise and jade. The turquoise imitations are more difficult to distinguish than the jade, but the vitreous luster of glass is usually apparent. **GROSSULARITE GARNET ("South African Jade")** occurs in a translucent form in a medium tone of green resembling jadeite. It is characterized by small black inclusions visible to the unaided eye. **IDOCRASE**, often sold as "California Jade," is found mottled in light and medium green patches similar to jadeite, but with less intense green color. **JADEITE** occurs in a medium tone of green with a very high intensity. White patches are usually present in the emerald-green jadeite. **LABRADORITE FELDSPAR**, a semitranslucent gemstone, usually has a gray body color and exhibits blue or green iridescence. **LAZULITE** is a semitranslucent to opaque gem mineral that is sometimes used as a substitute for lapis lazuli. It has a dark to very dark violetish-blue color that is usually broken by white patches. **LAZURITE (LAPIS LAZULI)** occurs in dark tones of violetish-blue. It is characterized by the presence of visible pyrite (brass yellow) inclusions. **MALACHITE** occurs only in medium to dark tones of a green hue. It is usually banded in medium and dark tones of green, and often occurs with dark blue azurite. **MICROCLINE FELDSPAR (AMAZONITE)** is a translucent to semitranslucent gem mineral that occurs in light to medium tones of blue-green with a "grid-like" or "shredded" appearance. **NEPHRITE JADE** occurs in a medium to dark grayish-green. The color often resembles that of spinach. **OPAL (BLACK OPAL)** is included with green and

Identification of Nontransparent Blue, Green Gems

blue gems because of the characteristic green and blue play of color. **PLASTICS** are made to imitate turquoise and jade. Plastic imitations of nontransparent gems are usually detected on sight by their unnatural appearance. **QUARTZ (AVENTURINE)** is a white quartz with a multitude of tiny green inclusions. Aventurine is often mistaken for poor quality jadeite. **CAT'S-EYE QUARTZ** is often blue-gray in color and semitranslucent. It lacks the silky luster and the sharp eye of precious cat's-eye (chrysoberyl). **SERPENTINE** in medium to dark tones of green is used as a substitute for jadeite. **TURQUOISE** is an intense light blue (sky blue) to blue-green gemstone. **VARISCITE** occurs in light tones of a yellowish-green hue. It is used as a turquoise substitute, but never occurs in the fine blue color of gem quality turquoise. **DOUBLET** substitutes are used only for opal among nontransparent gems. The back piece is used primarily to lend strength to a thin piece of opal. **FOIL BACKS** to imitate star sapphires are now common in the trade. They are made from almost colorless star quartz, with a blue mirror to produce a blue color and enhance the star.

Testing Procedure. The identification procedure for nontransparent materials must be modified because such tests as the examination of inclusions, the determination of single and double refraction and refractometer readings cannot be made on an opaque substance (one which transmits no light, even through thin edges). These tests are included for translucent gems, but should be eliminated if the gem is opaque. The determination of the physical properties, specific gravity and hardness, assumes a vital importance in the identification of opaque materials.

Initial Examination. Clean the stone and examine it with the unaided eye or a low power loupe for any unusual property or appearance. Since many nontransparent gemstones occur in but a single color and several have unusual appearances that assist materially in their identification, the initial examination is important. Observation of any of the following properties may

identify the unknown or indicate the necessity for but a single test to establish its identity.

Intense dark blue gem with flecks of pyrite (brass yellow) suggests lazurite (lapis lazuli).

Intense light blue color suggests turquoise or a substitute.

Dull or waxy luster on a fracture surface of a translucent green or blue gem suggests chalcedonic quartz.

A light and dark yellowish-green agate-like banding in an opaque green stone suggests malachite.

A deep violetish-blue stone with patches of green suggests azurite and malachite.

A six-rayed star suggests corundum (star sapphire) or a quartz foil back.

A coated back on a star stone indicates a quartz foil back.

A play of color suggests opal.

A blue or green iridescence suggests labradorite feldspar.

Warmth to the touch (compared to the cold feel of crystalline materials) suggests a plastic, glass or opal.

Small black spots in a translucent green stone suggests grossularite garnet.

A single sharp band of reflected light across the crest of a gem with a silky luster suggests chrysoberyl (cat's-eye).

A spinach-green color in a translucent gem suggests nephrite jade.

A "shredded" or grid-like appearance in a light blue-green semitranslucent gem suggests amazonite (microcline feldspar).

Examination Under Magnification. The tests which follow will be given as if the gem were translucent. If the gem is opaque, eliminate examination under magnification and the polariscope test. If the gem is not opaque, examine it under a magnification of 10X to 50X. Since it is sometimes impossible to determine the artificial or natural origin of nontransparent gems by magnification, the observer will occasionally find magnification of no assistance. It is often possible, however, to detect a

Identification of Nontransparent Blue, Green Gems

structure suggestive of a natural or artificial material without aid of magnification in translucent or opaque gemstones. Dye on chalcedony may be detected in this test by the accumulation of the coloring agent in minute surface irregularities.

NATURAL, NONTRANSPARENT, BLUE AND GREEN GEMSTONES. Magnification should divulge the origin of the following:

Chrysoberyl (cat's-eye)	Jadeite jade
Chalcedonic quartz (chrysoprase or chrysocolla quartz or dyed chalcedony)	Labradorite feldspar
Corundum (star sapphire)	Microcline feldspar (amazonite)
Grossularite garnet	Nephrite jade
Idocrase	Opal (black opal)
	Quartz (aventurine and cat's-eye)

Origin of the following is difficult to detect by magnification:

Azurite	Malachite
Chalcedonic quartz (bloodstone)	Serpentine
Lazulite	Turquoise
Lazurite (lapis lazuli)	Variscite

ARTIFICIAL, NONTRANSPARENT, BLUE AND GREEN GEM MATERIALS. Magnification should divulge the origin of the following:

Glass	Plastics
-------	----------

NOTE: Opal doublets and quartz foil backs are not listed here since they can be identified on close inspection by unaided eye.

The Determination of Single or Double Refraction. If light can be seen through thin edges of the gem, examine it in the polariscope or under a polarizing microscope for single or double refraction. Double refraction may also be detected under magnification, on the refractometer or with the dichroscope. Since it is not often apparent in a translucent stone using the latter methods, failure to discover double refraction is NOT proof of single refraction. Directions for operation of the instru-

ments used in detecting single and double refraction are given in Chapter VI.

Before attempting to determine the singly or doubly refractive character of the gem, be certain that light can be seen through a portion of the gem when it is mounted in the polariscope with the top Polaroid turned so that a maximum amount of light passes through the instrument.

DOUBLY REFRACTIVE, NONTRANSPARENT, NATURAL, BLUE AND GREEN GEMSTONES.

Those through which too little light passes for polariscopic determinations:

Chalcedonic quartz (chrysoprase and chrysocolla quartz and dyed chalcedony)	Idocrase
Chrysoberyl (cat's-eye)	Jadeite jade
Corundum (star sapphire)	Nephrite jade
	Quartz (aventurine and cat's-eye)

Those through which too little light passes for polariscopic determinations:

Azurite	Malachite
Chalcedonic quartz (bloodstone)	Microcline feldspar (amazonite)
Labradorite feldspar	Serpentine
Lazulite	Turquoise
	Variscite

SINGLY REFRACTIVE, NONTRANSPARENT, NATURAL, BLUE AND GREEN GEMSTONES.

Those through which enough light usually passes to permit determination of single refraction by the polariscope:

Grossularite garnet	Opal (black opal)
---------------------	-------------------

Too little light passes for a polariscopic determination:

Lazurite (lapis lazuli)

SINGLY REFRACTIVE, NONTRANSPARENT, ARTIFICIAL, BLUE AND GREEN GEM MATERIALS.

Glass	Plastics
-------	----------

Identification of Nontransparent Blue, Green Gems

The test for pleochroism is omitted in the identification of nontransparent gemstones.

The Determination of Refractive Index. Place the stone on a refractometer to determine the refractive index. Translucent stones with a flat facet usually give an indistinct shadow. If no reading is obtained, or if the reading is inconclusive, an approximate index may be determined in some cases by means of the approximate immersion method.

REFRACTIVE INDICES OF NATURAL, DOUBLY REFRACTIVE, NON-TRANSPARENT, BLUE OR GREEN GEMSTONES.

Corundum (star sapphire).....	1.762 to 1.770
Chrysoberyl (cat's-eye)	1.746 to 1.755
Azurite*	1.73 to 1.84
Idocrase	1.713 to 1.718
Malachite*	1.66 to 1.91
Jadeite jade	1.66 to 1.68
Turquoise	1.61 to 1.65
Lazulite	1.61 to 1.64
Nephrite jade	1.606 to 1.632
Variscite	1.56 to 1.59
Labradorite feldspar	1.559 to 1.566
Quartz (aventurine and cat's-eye).....	1.544 to 1.533
Chalcedonic quartz	1.535 to 1.539
Microcline feldspar (amazonite).....	1.522 to 1.530
Serpentine*	1.49 to 1.57

*Gemstones unlikely to give a refractometer reading.

The gemstones which resemble one another visually have refractive indices that are considerably spread, making positive identification certain if a refractometer reading is obtainable.

REFRACTIVE INDICES OF NATURAL, SINGLY REFRACTIVE, NON-TRANSPARENT, GEMSTONES:

Grossularite garnet	1.745
Lazurite (lapis lazuli)	1.50
Opal (black opal)	1.45

REFRACTIVE INDICES OF ARTIFICIAL, SINGLY REFRACTIVE, NON-TRANSPARENT, GEM MATERIALS.

Glass (normal range)	1.48 to 1.70
Plastics	1.49 to 1.67

HANDBOOK OF GEM IDENTIFICATION

The Determination of Specific Gravity. This is the most important single test in the identification of opaque gemstones.

SPECIFIC GRAVITIES OF NATURAL, NONTRANSPARENT, BLUE AND GREEN GEMSTONES.

Corundum (star sapphire).....	4.00 ($\pm .05$)
Malachite	3.95 ($\pm .15$)
Azurite	3.87 ($\pm .07$)
Chrysoberyl (cat's-eye)	3.73 ($\pm .02$)
Grossularite garnet	3.61 ($-.04, +.12$)
Idocrase	3.40 ($\pm .06$)
Jadeite jade	3.34 ($\pm .04$)
Lazulite	3.09 ($\pm .05$)
Nephrite jade	2.95 ($\pm .05$)
Turquoise	2.76 ($-.15, +.08$)
Lapis-lazuli (not pure lazurite).....	2.75 ($-.20, +.07$)
Labradorite feldspar	2.70 ($\pm .02$)
Quartz (aventurine and cat's-eye).....	2.66 ($\pm .01$)
Chalcedonic quartz	2.61 ($\pm .01$)
Serpentine	2.57 ($\pm .06$)
Microcline feldspar (amazonite).....	2.56 ($\pm .01$)
Variscite	2.50 ($\pm .08$)
Opal (black opal).....	2.15 ($\pm .02$)

SPECIFIC GRAVITIES OF ARTIFICIAL, NONTRANSPARENT, BLUE AND GREEN GEM MATERIALS.

Plastics	1.18 to 1.55
Glass (extreme range)	2.2 to 4.5
Normal range for translucent and opaque glass	2.3 to 2.7

The only natural gemstones which are not adequately separated by the determination of specific gravity are idocrase and jadeite jade. Since they cannot be distinguished by hardness or specific gravity, it is necessary to obtain their refractive indices. If the unknown stone lacks a flat facet on which to make a refractometer reading, it is necessary to compare the unknown gem to idocrase or jadeite jade for relative relief when immersed in pure methylene iodide. Jadeite stands out in bolder relief.

Glass, which may have the same specific gravity as any natural nontransparent blue or green gem, is detected by its vitreous luster, bubbles near the surface, or sometimes by its hardness.

Identification of Nontransparent Blue, Green Gems

The Hardness Test. Do not make a hardness determination unless it is essential to the identification. Be sure that it will separate the possibilities that remain.

NONTRANSPARENT BLUE AND GREEN GEMS AND THEIR SUBSTITUTES HAVE THE FOLLOWING HARDNESSES:

Corundum (star sapphire).....	9
Chrysoberyl (cat's-eye)	8½
Grossularite garnet	7
Quartz (aventurine and cat's-eye).....	7
Chalcedonic quartz (chrysoprase, bloodstone and dyed chalcedony)	6½-7
Jadeite jade	6½-7
Idocrase	6½
Microcline feldspar (amazonite).....	6 -6½
Nephrite jade	6 -6½
Labradorite feldspar	6
Opal (black opal).....	5 -6½
Lapis lazuli	5 -6
Turquoise	5 -6
Lazulite	5 -6
Glass	5 -6
Serpentine	5 -5½
Variscite	4 -5
Azurite	3½-4
Malachite	3½-4
Plastics	2 -4½

The hardness test is seldom required even in the identification of opaque gem materials, since materials in this group which are similar in appearance are usually distinguished easily by other methods or have the same hardnesses. However, glass and plastic imitations of the harder gems may be detected by a hardness determination. If the unknown opaque gemstone is mounted, or if the tester lacks specific gravity equipment, a hardness test is essential.

Chapter XXIII

The Identification of Nontransparent Red, Yellow and Brown Gemstones and Their Substitutes

NONTRANSPARENT GEMSTONES AND THEIR SUBSTITUTES WHICH OCCUR IN A RED COLOR:

Almandite garnet (star garnet)	Glass
Chalcedonic quartz (sard, sard- onyx and carnelian)	Plastics
Coral	Quartz (cat's-eye quartz)
Corundum (star ruby)	Rhodonite
	Foil Backs

NONTRANSPARENT GEMSTONES AND THEIR SUBSTITUTES WHICH OCCUR IN A YELLOW COLOR:

Amber	Jadeite jade
Chalcedonic quartz	Plastics
Chrysoberyl (cat's-eye)	Quartz (cat's-eye)

NONTRANSPARENT GEMSTONES AND THEIR SUBSTITUTES WHICH OCCUR IN A BROWN COLOR:

Amber	Opal
Chrysoberyl (cat's-eye)	Plastics
Corundum (star sapphire)	Quartz (tiger eye)

Descriptions of Nontransparent Red, Yellow and Brown Gemstones and their Substitutes. ALMANDITE GARNET (STAR GARNET) occurs in a dark to very dark violetish-red color and exhibits a four-rayed star. AMBER of poor quality is translucent to semitranslucent and has a yellow-brown color. CHALCEDONIC QUARTZ (CARNELIAN AND SARD) are translucent va-

Identifying Nontransparent Red, Yellow, Brown Gems

rieties of orange-red and brown color. Sard is darker and more brown than carnelian which is lighter orangy-red. SARDONYX is banded sard and white chalcedony. CHRYSOBERYL (CAT'S-EYE) occurs in light to medium tones of greenish-yellow hue. It is translucent to semitranslucent. CORAL is a light to medium orangy-red semitranslucent gemstone. CORUNDUM (STAR RUBY) occurs in medium tones of violetish-red. The lighter and darker tones of red and violet are called star sapphire. Star sapphires may also have a dark brown body color with the star outlined as silky yellow-brown streaks of light. GLASS is manufactured to imitate chalcedonic quartz. JADEITE JADE occurs in medium tones of a yellow to yellow-green hue. OPAL of a soft yellowish-brown hue is occasionally cut as a gem. PLASTICS are molded to imitate amber. CATS-EYE QUARTZ AND TIGER-EYE QUARTZ are both used in a golden brown color. Cat's-eye quartz also occurs in red and yellow hues. It lacks the fine silky luster and the narrow, well defined eye of precious cat's-eye (chrysoberyl). RHODONITE is a semitranslucent gem mineral which occurs in a light to medium red color sometimes called flesh-red. It usually has black inclusions. FOIL BACKS of star quartz with a red mirror to lend a ruby color and to enhance the star, are common in the jewelry trade.

Testing Procedure. The identification procedure for nontransparent materials must be modified because such tests as the examination of inclusions, the determination of single and double refraction and refractometer readings cannot be made on an opaque substance (one which transmits no light, even through thin edges). These tests are included for translucent gems, but should be eliminated if the gem is opaque. The determination of the physical properties, specific gravity and hardness assumes a vital importance in the identification of opaque materials.

Initial Examination. Clean the stone and examine it with the unaided eye or a low power loupe for any unusual property

or appearance. Since many nontransparent gemstones occur in but a single color and several have unusual appearances that assist materially in their identification, the initial examination is important. Observation of any of the following properties may identify the unknown or indicate the necessity for but a single test to establish its identity.

Warmth to the touch (compared to the cold feel of crystalline materials) suggests amber, glass, opal or plastics.

A noticeably low specific gravity suggests amber or plastics.

A six-rayed star suggests star sapphire, star ruby or a star quartz foil back.

A dull or waxy luster on a fracture surface of a translucent red or yellow gem suggests chalcedonic quartz.

A four-rayed star suggests star garnet.

Color banding suggests chalcedonic quartz.

A flesh red color suggests coral or rhodonite.

A single band of light across the crest of a gem cut en cabochon suggests precious cat's-eye (chrysoberyl) or cat's-eye quartz.

A molded appearance on the back of a gem suggests glass.

Examination Under Magnification. The tests which follow will be given as if the gem were translucent. If the gem is opaque, eliminate examination under magnification and the polariscope test. If the gem is not opaque, examine it under a magnification of 10X to 50X. Since it is sometimes impossible to determine the artificial or natural origin of nontransparent gems by magnification, the observer will occasionally find magnification of no assistance. It is often possible, however, to detect a structure suggestive of a natural or artificial material without aid of magnification in translucent or opaque gemstones.

NATURAL, NONTRANSPARENT, RED, YELLOW AND BROWN GEMSTONES.

Magnification should divulge the origin of the following:

Identifying Nontransparent Red, Yellow, Brown Gems

Almandite garnet	Corundum (star ruby and star sapphire)
Amber	Jadeite jade
Chalcedonic quartz	Quartz (cat's-eye)
Chrysoberyl (cat's-eye)	

Origin of the following difficult to detect by magnification:

Coral	Rhodonite
Opal	

ARTIFICIAL, NONTRANSPARENT, RED, YELLOW AND BROWN GEM MATERIALS.

Magnification should divulge the origin of the following:

Glass	Plastics
-------	----------

NOTE: Star quartz foil backs are identified by a close inspection of the back.

The Determination of Single or Double Refraction.

If light can be seen through thin edges of the gem, examine it in the polariscope or under a polarizing microscope for single or double refraction. Double refraction may also be detected under magnification, on the refractometer or with the dichroscope. Since it is not often apparent in a translucent stone using the latter methods, failure to discover double refraction is NOT proof of single refraction. Directions for operation of the instruments used in detecting single and double refraction are given in Chapter VI.

Before attempting to determine the singly or doubly refractive character of the gem, be certain that light can be seen through a portion of the gem when it is mounted in the polariscope with the top Polaroid turned so that a maximum amount of light passes through the instrument.

DOUBLY REFRACTIVE, NONTRANSPARENT, NATURAL, RED, YELLOW AND BROWN GEMSTONES.

Those through which enough light usually passes to permit determination of double refraction by the polariscope:

HANDBOOK OF GEM IDENTIFICATION

Chalcedonic quartz	Jadeite jade
Chrysoberyl (cat's-eye)	Quartz (cat's-eye)
Corundum (star ruby or star sapphire)	

Those through which too little light passes for a polariscopic determination:

Coral	Rhodonite
-------	-----------

SINGLY REFRACTIVE. NONTRANSPARENT, NATURAL, RED, YELLOW AND BROWN GEMSTONES.

Those through which enough light usually passes to permit determination of single refraction by the polariscope:

Opal	Amber
------	-------

Those through which too little light passes for a polariscope determination:

Almandite garnet (star garnet)

SINGLY REFRACTIVE, NONTRANSPARENT, ARTIFICIAL, RED, YELLOW AND BROWN GEM MATERIALS.

Glass	Plastics
-------	----------

The test for pleochroism is omitted in the identification of non-transparent gemstones.

The Determination of Refractive Index. Place the stone on a refractometer to determine the refractive index. Translucent stones with a flat facet usually give an indistinct shadow. If no reading is obtained, or if the reading is inconclusive, an approximate index may be determined in some cases by means of the approximate immersion method.

REFRACTIVE INDICES OF NATURAL, DOUBLY REFRACTIVE, NON-TRANSPARENT, RED, YELLOW OR BROWN GEMSTONES.

Corundum (star sapphire and star ruby)	1.762 to 1.770
Chrysoberyl (cat's-eye).....	1.746 to 1.755
Rhodonite	1.73 to 1.74
Jadeite jade	1.66 to 1.68
Coral	*
Quartz (cat's-eye and tiger eye).....	1.544 to 1.553
Chalcedonic quartz (carnelian and sard).....	1.535 to 1.539

* Composed largely of calcite (1.486-1.658). The index reading of coral is usually about 1.60.

Identifying Nontransparent Red, Yellow, Brown Gems

The gemstones which resemble one another visually have refractive indices that are considerably spread, making positive identification certain if a refractometer reading is obtainable.

REFRACTIVE INDICES OF NATURAL, SINGLY REFRACTIVE, NON-TRANSPARENT, GEMSTONES.

Almandite garnet (star garnet)	1.81
Amber	1.54
Opal	1.45

REFRACTIVE INDICES OF ARTIFICIAL, SINGLY REFRACTIVE, NON-TRANSPARENT, GEM MATERIALS.

Glass (normal range).....	1.48 to 1.70
Plastics	1.49 to 1.67

The Determination of Specific Gravity. This is the most important single test in the identification of opaque gemstones.

SPECIFIC GRAVITIES OF NATURAL, NONTRANSPARENT, RED, YELLOW AND BROWN GEMSTONES.

Almandite garnet (star garnet).....	4.05 (\pm .12)
Corundum (star sapphire and star ruby).....	4.00 (\pm .05)
Chrysoberyl (cat's-eye)	3.73 (\pm .02)
Rhodonite	3.53 (\pm .11)
Jadeite jade	3.34 (\pm .04)
Quartz (cat's-eye and tiger eye).....	2.66 (\pm .01)
Coral	2.65 (\pm .05)
Chalcedonic quartz (sard and carnelian).....	2.61 (\pm .03)
Opal	2.15 (\pm .08)
Amber	1.08 (\pm .02)

SPECIFIC GRAVITIES OF ARTIFICIAL, NONTRANSPARENT, RED, YELLOW AND BROWN GEM MATERIALS.

Glass (extreme range)	2.2 to 4.5
Normal range for translucent and opaque gems	2.3 to 2.7
Plastics	1.18 to 1.55

With the exception of quartz and coral, the natural gemstones are adequately separated by the determination of specific gravity. There is no quartz variety which resembles coral, but if doubt

remains, place a drop of muriatic acid on the unknown. If it is coral, the drop will cause effervescence.

Glass, which may have the same specific gravity as any natural nontransparent, red, yellow or brown gem, is detected by its vitreous luster, bubbles near the surface, or sometimes by its hardness.

The Hardness Test. Do not make a hardness determination unless it is essential to the identification. Be sure that it will separate the possibilities that remain.

NONTRANSPARENT, RED, YELLOW AND BROWN GEMS AND THEIR SUBSTITUTES HAVE THE FOLLOWING HARDNESSES:

Corundum (star sapphire and star ruby).....	9
Chrysoberyl (cat's-eye)	8½
Almandite garnet (star garnet).....	7½
Quartz (cat's-eye and tiger eye).....	7
Chalcedonic quartz (sard and carnelian).....	6½-7
Jadeite jade	6½-7
Rhodonite	5½-6
Opal	5 -6½
Glass	5 -6
Coral	3½
Plastics	2 -4½
Amber	2 -4

The hardness test is seldom required even in the identification of opaque gem materials, since materials in this group which are similar in appearance are usually distinguished easily by other methods or have the same hardnesses. However, glass and plastic imitations of the harder gems may be detected by a hardness determination. If the unknown opaque gemstone is mounted, or if the tester lacks specific gravity equipment, a hardness test is essential.

Chapter XXIV

The Identification of Nontransparent White, Gray and Black Gemstones and Their Substitutes

NONTRANSPARENT GEMSTONES AND THEIR SUBSTITUTES WHICH OCCUR IN A WHITE COLOR.

Chalcedonic quartz (chalcedony moonstone)	Opal
Glass	Opal doublets
Jadeite jade	Orthoclase feldspar (moonstone)
Nephrite jade	Plastics

NONTRANSPARENT GEMSTONES AND THEIR SUBSTITUTES WHICH OCCUR IN A GRAY COLOR.

Chalcedonic quartz (agate)	Jadeite jade
Corundum (star sapphire)	Labradorite feldspar
Hematite	Nephrite jade
Hemetine	

NONTRANSPARENT GEMSTONES AND THEIR SUBSTITUTES WHICH OCCUR IN A BLACK COLOR.

Andradite garnet (melanite)	Jadeite jade
Chalcedonic quartz (black onyx)	Jet
Corundum (star sapphire)	Nephrite jade
Diamond	Obsidian
Glass	Opal
Hematite	Opal doublets
Hemetine	Plastics

Descriptions of Nontransparent White, Gray and Black Gemstones and their Substitutes. **ANDRADITE GARNET (MELANITE)** is a black lustrous material occasionally cut en ca-

bochon. Its high luster distinguishes it from black onyx or nephrite jade. CHALCEDONIC QUARTZ (CHALCEDONY MOONSTONE) as a 1.00-transparent white gem resembles precious moonstone without the bluish sheen. Gray and white banded AGATE is used in inexpensive jewelry. Various types of chalcedony are dyed black to produce the common black onyx. CORUNDUM (STAR SAPPHIRE) is most common in a reddish to bluish-gray color. Black star sapphires, with the star outlined as yellow-brown streaks with a silky appearance, are rare and prized. DIAMOND in a dark brown to black nontransparent form is often cut as a brilliant. GLASS is used to imitate black onyx and banded material. It is usually molded and not polished, which makes identification upon sight a simple matter. HEMATITE is a dark metallic gray mineral commonly used for men's rings. HEMETINE (trademark) includes various materials used as substitutes for hematite. JADEITE JADE is found in the trade both as a white and as a black gem. The white form usually has small patches of an emerald-green color. JET, once common, is almost never used as a gem today. It is black with a soft luster. LABRADORITE FELDSPAR has a medium gray body color and is characterized by a blue or green iridescence. NEPHRITE JADE is rarely used in its white and gray forms but in a black color it is finding increasing use. It is more lustrous and tougher than black onyx. OPAL (BLACK OPAL AND WHITE OPAL) is characterized by vivid flashes of color. OPAL DOUBLETS are so common that every opal should be carefully examined for this possibility. OBSIDIAN is a black natural glass often cut en cabochon. ORTHOCLASE FELDSPAR (MOONSTONE) is a white translucent gem characterized by a lovely blue sheen in reflected light. PLASTICS are made to imitate precious moonstone, jet and black onyx. Except in the imitation of jet there is little resemblance to the natural gem.

Procedure for Identification. The identification procedure for nontransparent materials must be modified because such tests as the examination of inclusions, the determination of single and double refraction and refractometer readings cannot be

Identifying Nontransparent White, Gray, Black Gems

made on an opaque substance (one which transmits no light, even through thin edges). These tests are included for translucent gems, but should be eliminated if the gem is opaque. The determination of the physical properties, specific gravity and hardness, assumes a vital importance in the identification of opaque materials.

Initial Examination. Clean the stone and examine it with the unaided eye or a low power loupe for any unusual property or appearance. Since many nontransparent gemstones occur in but a single color and several have unusual appearances that assist materially in their identification, the initial examination is important. Observation of any of the following properties may identify the unknown or indicate the necessity for but a single test to establish its identity.

A blue sheen in reflected light suggests precious moonstone (orthoclase feldspar).

A play of color suggests opal. Since opal doublets are common, check every opal for that possibility by an examination of the girdle and back.

A blue or green iridescence in a gray gemstone suggests labradorite feldspar.

A six-rayed star suggests star sapphire.

Warmth to the touch (compared to the cold feel of crystalline materials) suggests a plastic, glass or opal.

A metallic luster suggests hematite or a substitute.

A molded surface appearance suggests glass or a plastic.

A vitreous luster on fracture surfaces suggests glass.

A dull or waxy luster on a fracture surface suggests chalcedonic quartz.

A straight flat crack suggests orthoclase or labradorite feldspar.

Examination Under Magnification. The tests which follow will be given as if the gem were translucent. If the gem is opaque, eliminate examination under magnification and the po-

lariscope test. If the gem is not opaque, examine it under a magnification of 10X to 50X. Since it is sometimes impossible to determine the artificial or natural origin of nontransparent gems by magnification, the observer will occasionally find magnification of no assistance. It is often possible, however, to detect a structure suggestive of a natural or artificial material without aid of magnification in a translucent or opaque gemstone.

NATURAL, NONTRANSPARENT, WHITE, GRAY AND BLACK GEMSTONES.

Origin of the following is difficult to detect by magnification:

Andradite garnet (melanite)	Hematite
Chalcedonic quartz (black onyx)	Jet
Diamond	Nephrite jade (black)
Jadeite jade (black)	Obsidian

Magnification should divulge the origin of the following:

Labradorite feldspar	Jadeite jade (white and gray)
Chalcedonic quartz (chalcedony moonstone and agate)	Orthoclase feldspar (moonstone)
Corundum (star sapphire)	Opal (black and white opal)

ARTIFICIAL, NONTRANSPARENT, WHITE, GRAY AND BLACK GEM MATERIALS.

Origin of the following is difficult to detect by magnification:

Glass	Plastics
Hemetine	

NOTE: Opal doublets are not listed here since they can be identified on close inspection by unaided eye.

The Determination of Single or Double Refraction. If light can be seen through thin edges of the gem, examine it in the polariscope or under a polarizing microscope for single or double refraction. Double refraction may also be detected under magnification, on the refractometer or with the dichroscope. Since it is not often apparent in a translucent stone using the latter methods, failure to discover double refraction is NOT proof of single refraction. Directions for operation of the instruments used in detecting single and double refraction are given in Chapter VI.

Identifying Nontransparent White, Gray, Black Gems

Before attempting to determine the singly or doubly refractive character of the gem, be certain that light can be seen through a portion of the gem when it is mounted in the polariscope with the top Polaroid turned so that a maximum amount of light passes through the instrument.

DOUBLY REFRACTIVE, NONTRANSPARENT, NATURAL, WHITE, GRAY AND BLACK GEMSTONES.

Those through which enough light usually passes to permit determination of double refraction by the polariscope:

Chalcedonic quartz (chalcedony moonstone and agate)	Jadeite jade (white and gray)
Corundum (star sapphire)	Orthoclase feldspar (moonstone)

Those through which too little light passes for polariscopic determinations:

Hematite	Labradorite feldspar
Jadeite jade (black)	Nephrite jade (black)

SINGLY REFRACTIVE, NONTRANSPARENT, NATURAL, WHITE, GRAY AND BLACK GEMSTONES.

Those through which enough light usually passes to permit determination of single refraction by the polariscope:

Obsidian	Opal
----------	------

Those through which too little light passes for a polariscopic determination:

Andradite garnet (melanite)	Jet
Diamond	

SINGLY REFRACTIVE, NONTRANSPARENT, ARTIFICIAL, WHITE, GRAY AND BLACK GEMSTONES.

Glass	Plastics
Hemetine (always opaque)	

The test for pleochroism is omitted in the identification of non-transparent gemstones.

The Determination of Refractive Index. Place the stone on a refractometer to determine the refractive index. Translucent stones with a flat facet usually give an indistinct shadow. If no reading is obtained, or if the reading is inconclusive, an approximate index may be determined in some cases by means of the approximate immersion method.

REFRACTIVE INDICES OF NATURAL, DOUBLY REFRACTIVE, NONTRANSPARENT, WHITE, GRAY OR BLACK GEMSTONES.

Hematite	opaque
Corundum (star sapphire).....	1.762 to 1.770
Jadeite jade	1.66 to 1.68
Nephrite jade	1.606 to 1.632
Labradorite feldspar	1.559 to 1.566
Chalcedonic quartz	1.535 to 1.539
Orthoclase feldspar	1.518 to 1.526

The gemstones which resemble one another visually have refractive indices that are considerably spread, making positive identification certain if a refractometer reading is obtainable.

REFRACTIVE INDICES OF NATURAL, SINGLY REFRACTIVE, NONTRANSPARENT, GEM MATERIALS.

Diamond	2.417
Andradite garnet (melanite)	1.885
Obsidian	1.50
Opal	1.45
Jet	opaque

REFRACTIVE INDICES OF ARTIFICIAL, SINGLY REFRACTIVE, NONTRANSPARENT, GEM MATERIALS:

Hemetine	opaque
Glass (normal range).....	1.48 to 1.70
Plastics	1.49 to 1.67

The Determination of Specific Gravity. This is the most important single test in the identification of opaque gemstones.

Identifying Nontransparent White, Gray, Black Gems

SPECIFIC GRAVITIES OF NATURAL, NONTRANSPARENT, WHITE, GRAY AND BLACK GEMSTONES.

Hematite	5.20
Hemetine	4.0 to 7.0
Corundum (star sapphire).....	4.00 ($\pm .05$)
Andradite garnet (melanite).....	3.84 ($\pm .03$)
Diamond	3.52 ($\pm .01$)
Jadeite jade	3.34 ($\pm .04$)
Nephrite jade	2.95 ($\pm .05$)
Labradorite feldspar	2.70 ($\pm .02$)
Chalcedonic quartz	2.61 ($\pm .03$)
Orthoclase feldspar	2.56 ($\pm .01$)
Obsidian	2.45 ($\pm .10$)
Opal	2.15 ($\pm .08$)
Jet	1.30 ($\pm .02$)

SPECIFIC GRAVITIES OF ARTIFICIAL, NONTRANSPARENT, WHITE, GRAY AND BLACK GEM MATERIALS.

Plastics	1.18 to 1.55
Glass (extreme range).....	2.2 to 4.5
Normal range for transparent and opaque glass.....	2.3 to 2.7

The specific gravities of the gemstones listed here are sufficiently widely separated so that this determination will permit a positive identification.

Glass, which may have the same specific gravity as any natural nontransparent white, gray or black gem is detected by its vitreous luster, bubbles near the surface, or sometimes by its hardness.

The Hardness Test. Do not make a hardness determination unless it is essential to the identification. Be sure that it will separate the possibilities that remain.

Nontransparent white, gray and black gems and their substitutes have the following hardnesses:

Diamond	10
Corundum (star sapphire).....	9
Chalcedonic quartz	6½-7
Jadeite jade	6½-7
Andradite garnet (melanite).....	6½-7

HANDBOOK OF GEM IDENTIFICATION

Orthoclase feldspar (moonstone).....	6	-6½
Nephrite jade	6	-6½
Labradorite feldspar	6	
Hematite	5½	-6½
Opal	5	-6½
Glass	5	-6
Obsidian	5	-5½
Jet	3	-4
Hemetine	2½	-5
Plastics	2	-4½

The hardness given for HEMETINE is 2½ to 5. Usually, the higher the specific gravity of HEMETINE, the lower will be its hardness. If the specific gravity is near 7.0, the hardness usually is less than 3.

The hardness test is seldom required even in the identification of opaque gem materials, since materials in this group which are similar in appearance are usually distinguished easily by other methods or have the same hardnesses. However, glass and plastic imitations of the harder gems may be detected by a hardness determination. If the unknown opaque gemstone is mounted, or if the tester lacks specific gravity equipment, a hardness test is essential.

Appendix

OPTIC CHARACTER TABLE

SINGLY REFRACTIVE.

Isometric (Cubic). Diamond; almandite, andradite, grossularite, pyrope, rhodolite and spessartite garnet; fluorite; lazurite; spinel; synthetic spinel.
Amorphous. Glass; moldavite; obsidian; opal; plastics.

DOUBLY REFRACTIVE.

Uniaxial, positive. Benitoite; quartz; phenacite; zircon.
Uniaxial, negative. Apatite; beryl; corundum; idocrase; tourmaline.
Biaxial, positive. Chrysoberyl; euclase; labradorite feldspar, peridot; sphene; spodumene; topaz.
Biaxial, negative. Andalusite; axinite; beryllonite; brazilianite; iolite; kornerupine; kyanite; microcline feldspar; orthoclase feldspar.

TABLE OF DISPERSION

The following figures represent the difference in the gem's refractive index for red light and blue-violet light.

Fluorite007	Kornerupine019
Silica glass010	Idocrase019
Beryllonite010	PERIDOT020
Kyanite011	SPINEL020
ORTHOCLASE FELDSPAR .	.012	Dioptase022
QUARTZ013	ALMANDITE GARNET .	.024
BERYL014	Rhodolite Garnet026
TOPAZ014	PYROPE GARNET027
Phenacite015	Spessartite Garnet . .	.027
CHRYSOBERYL015	GROSSULARITE GARNET .	.028
Fibrolite015	Epidote030
Euclase016	ZIRCON038
Danburite016	Benitoite044
Datolite016	DIAMOND044
Scapolite017	Sphene051
TOURMALINE017	ANDRADITE GARNET .	.057
SPODUMENE017	Cassiterite071
CORUNDUM018	Sphalerite156

Property Tables

TABLE OF BIREFRINGENCE OF GEMSTONES

Apatite004	Phenacite016
BERYL006	Euclase019
CORUNDUM008	Brazilianite019
TOPAZ008	TOURMALINE020
Andalusite009	Sillimanite021
CHRYSOBERYL009	PERIDOT038
Beryllonite010	ZIRCON059
SPODUMENE015	Sphene134
Kyanite016	Calcite172

REFRACTIVE INDEX TABLE

Gems Listed With Two Indices Are Doubly Refractive
 Important gemstones are listed in capital letters.

Rutile	2.616	2.903
Anatase	2.49	2.55
DIAMOND		2.417
Sphalerite		2.37
Cassiterite	2.00	2.09
ZIRCON (alpha, beta)	1.925	1.984
Sphene	1.900	2.034
ANDRADITE GARNET		1.885
ZIRCON (gamma)	1.810	1.815
Spessartite garnet		1.80
ALMANDITE GARNET		1.79
CORUNDUM	1.762(— .003, + .007)	1.770(— .003, + .003)
Rhodolite garnet		1.76
Benitoite	1.757	1.804
PYROPE GARNET		1.746
CHRYSOBERYL	1.746(± .004)	1.755(± .005)
GROSSULARITE GARNET		1.745(± .005)
Azurite	1.73	1.84
Epidote	1.729	1.768
SPINEL		1.726(± .014)
Idocrase	1.713	1.718
Kyanite	1.712	1.728
Hypersthene	1.703	1.716
Zoisite	1.700	1.706
Willemite	1.69	1.72
Axinite	1.678	1.688
Diopside	1.675	1.701
Kornerupine	1.665	1.677
Malachite	1.66	1.91
JADEITE	1.66	1.68
PERIDOT	1.659	1.697
Sillimanite	1.659	1.680
SPODUMENE	1.660(± .005)	1.676(± .005)
Diopase	1.655	1.708
Enstatite	1.655	1.665
Phenacite	1.654	1.670
Euclase	1.651	1.670
Apatite	1.642	1.646
Andalusite	1.634	1.643
Danburite	1.630	1.636
TOURMALINE	1.624(± .005)	1.644(± .006)
Smithsonite	1.621	1.849
TOPAZ	1.619(± .012)	1.627(± .012)
Prehnite	1.615	1.646
TUROUOISE	1.61	1.65
Lazulite	1.61	1.64

Property Tables

NEPHRITE	1.606	1.632
Coral	1.60	1.60
Brazilianite	1.598	1.617
BERYL	1.577 ($\pm .016$)	1.583 ($\pm .017$)
Variscite	1.56	1.59
LABRADORITE		
FELDSPAR	1.559	1.566
Beryllonite	1.552	1.562
QUARTZ	1.544 ($\pm .00$)	1.553 ($\pm .00$)
Iolite	1.542	1.551
AMBER	1.54	
OLIGOCLASE		
FELDSPAR	1.539	1.547
Nephelite	1.537	1.542
CHALCEDONY		
QUARTZ	1.535	1.539
Aragonite	1.530	1.685
MICROCLINE		
FELDSPAR	1.522	1.530
Thomsonite	1.520	1.542
ORTHOCLASE		
FELDSPAR	1.518	1.526
Cancrinite	1.50	1.52
LAZURITE (Lapis Lazuli)	1.50	
Obsidian	1.50	
Serpentine	1.49	1.57
Calcite	1.486	1.658
Sodalite	1.480	
Moldavite	1.48	
Chrysocolla	1.46	1.57
OPAL	1.45	
Fluorite	1.434	

SPECIFIC GRAVITY TABLE

Important gemstones are listed in capital letters.

Cassiterite	6.95 (±.08)	Fluorite	3.18 (±.01)
Hematite	5.20 (±.08)	Apatite	3.18 (±.02)
Pyrite	5.00 (±.10)	SPODU-	
Marcasite	4.80 (±.10)	MENE	3.18 (±.03)
ZIRCON		Andalusite	3.17 (±.04)
(alpha, beta)	4.70 (±.03)	TOUR-	
Smithsonite	4.30 (±.10)	MALINE	3.06 (±.05)
Rutile	4.25 (±.05)	Euclase	3.10 (±.01)
Spessartite		Lazulite	3.09 (±.05)
garnet	4.15 (±.03)	Danburite	3.00 (±.01)
ALMANDITE		NEPHRITE	
GARNET	4.05 (±.12)	JADE	2.95 (±.05)
Sphalerite	4.05 (±.02)	Phenacite	2.95 (±.01)
ZIRCON		Brazilianite	2.94
(gamma)	4.00 (±.07)	Aragonite	2.94 (±.02)
CORUNDUM	4.00 (±.05)	Beryllonite	2.85 (±.02)
Malachite	3.95 (±.15)	TUR-	
Celestite	3.90	QUOISE	2.76 (— .15, +.08)
Anatase	3.88 (±.05)	Steatite	2.75
ANDRADITE		LAPIS	
GARNET	3.84 (±.03)	LAZULI	2.75 (— .20, +.07)
Rhodolite		BERYL	2.72 (— .05, +.12)
Garnet	3.84 (±.10)	PEARL	2.70 (— .02, +.15)
Azurite	3.80 (±.07)	Calcite	2.71 (±.01)
PYROPE		LABRADORITE	
GARNET	3.78 (±.09)	FELDSPAR	2.70 (±.02)
CHRYSO-		Scapolite	2.70 (±.03)
BERYL	3.73 (±.02)	QUARTZ	2.66 (±.01)
Benitoite	3.64 (±.03)	OLIGOCLASE	
GROSSULARITE		FELDSPAR	2.65 (±.02)
GARNET	3.61 (— .04, +.12)	CORAL	2.65 (±.05)
Kyanite	3.60 (±.05)	CHALCEDONIC	
SPINEL		QUARTZ	2.61 (±.03)
Dark blue	3.60 (— .03, +.30)	Nephelite	2.60
Red, violet	3.60 (— .03, +.30)	Serpentine	2.57 (±.06)
Rhodonite	3.53 (±.11)	ORTHOCLASE	
TOPAZ	3.53 (±.04)	FELDSPAR	2.56 (±.01)
DIAMOND	3.52 (±.01)	MICROCLINE	
Sphene	3.52 (±.02)	FELDSPAR	2.56 (±.01)
Idocrase	3.40 (±.06)	Variscite	2.50 (±.08)
Epidote	3.40 (±.08)	Obsidian	2.45 (±.10)
PERIDOT	3.40 (±.08)	Lazurite	
JADEITE		(pure)	2.40
JADE	3.34 (±.04)	Moldavite	2.40
Dioptase	3.30 (±.05)	Sodalite	2.24
Dumortierite	3.30 (±.05)	Chrysocolla	2.20 (±.10)
Kornerupine	3.30 (±.05)	OPAL	2.15 (±.08)
Diopside	3.29 (±.03)	Meerschäum	
Axinite	3.29 (±.02)	(sepiolite)	2.00
Enstatite	3.25 (±.02)	JET	1.30 (±.02)
Sillimanite	3.24 (±.02)	AMBER	1.08 (±.02)

Property Tables

Relative Hardness of Gem Minerals*

HARDNESS: The resistance a gem offers to being scratched. Figures are relative, not absolute. Based upon Mohs' Scale of Hardness.

DIAMOND	10	LABRADORITE	
CORUNDUM	9	FELDSPAR	6
CHRYSOBERYL	8½	Hematite	5½-6½
SPINEL	8	Anatase	5½-6
TOPAZ	8	Beryllonite	5½-6
BERYL	7½-8	Nephelite	5½-6
Phenacite	7½-8	Moldavite	5½
ZIRCON	7½	Brazilianite	5½
ALMANDITE GARNET	7½	Enstatite	5½
Euclase	7½	Willemite	5½
PYROPE GARNET	7-7½	OPAL	5-6½
TOURMALINE	7-7½	Diopside	5-6
Iolite	7-7½	Lazulite	5-6
Andalusite	7-7½	LAPIS LAZULI	5-6
Spessartite garnet	7-7½	TURQUOISE	5-6
GROSSULARITE		Bowenite (serpentine)	5-5½
GARNET	7	Obsidian	5-5½
QUARTZ	7	Datolite	5-5½
CHALCEDONY		Sphene	5-5½
QUARTZ	6½-7	Thomsonite	5-5½
PERIDOT	6½-7	Apatite	5
JADEITE JADE	6½-7	Dioptase	5
ANDRADITE GARNET	6½-7	Smithsonite	5
Axinite	6½-7	Kyanite	4-7
Idocrase	6½	Variscite	4-5
Scapolite	6½	Diallage	4
SPODUMENE	6-7	Fluorite	4
Sillimanite	6-7	Azurite	3½-4
Epidote	6-7	Malachite	3½-4
Benitoite	6-6½	CORAL	3½
Pyrite	6-6½	JET	3-4
Rutile	6-6½	Calcite	3
MICROLINE		Serpentine	2½-4
FELDSPAR	6-6½	PEARL	2½-4½
ORTHOCLASE		Chrysocolla	2-4
FELDSPAR	6-6½	AMBER	2-2½
NEPHRITE JADE	6-6½	Steatite (soapstone)	1-2½

*Important gemstones are indicated by capital letters.

Properties of Gemstones and Their Substitutes.

NOTE: The property values given are average figures. For variations from average values, see the identification chapters or the tables of properties in the appendix.

Name and Crystal System	Color and Transparency	Average Refractive Indices	Hardness	Specific Gravity	In Appearance May Be Confused With
AMBER Amorphous	Usually yellow or brownish-yellow, also greenish, red, orange, yellowish-white. Translucent to transparent.	Single 1.54	2-2½	1.08	Pressed amber; other resins, artificial and natural; various plastics.
ANDALUSITE Orthorhombic	Yellow-green, gray-brown, reddish-brown, violet, light red. Transparent.	Double 1.63-1.64	7-7½	3.17	Tourmaline.
APATITE Hexagonal	Blue-green, blue, violet. Yellow, colorless. Transparent.	Double 1.542-1.646	5	3.18	Tourmaline; topaz; beryl; quartz.
AXINITE Triclinic	Greenish-yellow, brown, blue, violet. Transparent.	Double 1.678-1.688	6½-7	3.29	Hessonite; topaz; chrysoberyl; corundum.
AZURITE Monoclinic	Violetish-blue. Semi-transparent to opaque.	Double 1.73-1.84	3½-4	3.80	Lapis lazuli.
BAKELITE Amorphous	Produced in any color. Transparent to opaque.	Single 1.66	2½-3	1.26	Amber; jade; turquoise; etc.
BENITOITE Hexagonal	Pale to deep blue. Transparent.	Double 1.757-1.804	6-6½	2.72	Sapphire; spinel; glass.
BERYL Hexagonal	Colorless. Transparent.	Double 1.577-1.583	7½-8	3.64	
<i>Aquamarine</i>	Light blue to light green.				Topaz; apatite; sapphire; synthetic sapphire; synthetic spinel.

Property Tables of Gemstones and Their Substitutes

Name and Crystal System	Color and Transparency	Average Refractive Indices	Hardness	Specific Gravity	In Appearance May Be Confused With
<i>Emerald</i>	Green.				Synthetic emerald; tourmaline; peridot; fluorite; demantoid garnet; doublets; triplets; glass.
<i>Golden beryl</i>	Yellow to brown.				Topaz; quartz; garnet; glass.
<i>Morganite</i>	Light red to light purplish-red.				Spodumene; tourmaline; topaz; corundum; synthetic corundum; synthetic spinel; glass.
SYNTHETIC EMERALD					See emerald.
BERYLLONITE Orthorhombic	Colorless to yellow. Transparent.	Double 1.570-1.575	7½-8	2.65	
BRAZILIANITE Monoclinic	Greenish-yellow to yellow-green. Transparent.	Double 1.552-1.562	5½-6	2.85	
CASSITERITE Tetragonal	Brown, red-brown, yellow. Transparent to opaque.	Double 1.598-1.617	5½	2.94	Chrysoberyl; peridot.
CHRYSOBERYL Orthorhombic	Greenish-yellow, bluish-green, yellow-brown. Transparent to translucent.	Double 2.00-2.09	6-7	6.95	Sphene; zircon.
<i>Alexandrite</i>	Emerald green in daylight; red to violet in ordinary artificial light. Transparent.	Double 1.746-1.755	8½	3.73	Peridot; zircon; beryl; demantoid garnet, etc.; natural or synthetic sapphire or spinel; glass.
<i>Cat's-eye</i>	Translucent, when cut on cabochon shows a single, sharp, well-defined band of white light across the stone.				Synthetic alexandrite-like sapphire; synthetic spinel; andalusite.
CORAL Organic	Precious varieties have light orange-red hues. Semi-transparent to opaque.	Double 1.60	3½-4	2.65	Cat's-eye quartz; cat's-eye tourmaline. Glass.

HANDBOOK OF GEM IDENTIFICATION

Name and Crystal System	Color and Transparency	Average Refractive Indices	Hardness	Specific Gravity	In Appearance May Be Confused With
CORUNDUM Hexagonal <i>Ruby</i>	Red. Transparent.	Double 1.762-1.770	9	4.00	Spinel; garnet; tourmaline; synthetic ruby; synthetic spinel; doublet; glass.
<i>Sapphire</i>	Colorless, violet, blue, green, yellow, pink. Transparent.				Spinel; quartz; pale garnet; benitoite; topaz; beryl; chrysoberyl; zircon; etc.; synthetic sapphire; synthetic spinel; doublet; glass.
<i>Padparadsha</i>	Orange. Transparent.				Hessonite garnet; hyacinth zircon.
<i>Star ruby</i>	Red. Semitransparent to translucent.				Star quartz foil back.
<i>Star sapphire</i>	Blue, bluish-gray, violet, brown, pink, black. Semitransparent to semitranslucent.				Star quartz foil back.
SYNTHETIC CORUNDUM Hexagonal		Double 1.762-1.770	9	4.00	
<i>Synthetic ruby</i>	Red. Transparent.				See ruby.
<i>Synthetic sapphire</i>	See sapphire.				See sapphire.
DANBURITE Orthorhombic	Colorless, yellow, yellow-brown. Transparent.	Double 1.630-1.636	7	3.00	Topaz; beryl; quartz.
DIAMOND Cubic	Colorless, brown, light tones of red, violet, yellow, green, blue, etc., gray to almost black. Transparent to semitranslucent.	Single 2.417	10	3.52	Beryl; topaz; quartz; etc.; glass.
DIOPSIDE Monoclinic	Colorless, yellow, green, blue. Transparent.	Double 1.675-1.701	5-6	3.29	Emerald; sapphire; spinel.

Property Tables of Gemstones and Their Substitutes

Name and Crystal System	Color and Transparency	Average Refractive Indices	Hardness	Specific Gravity	In Appearance May Be Confused With
DIOPTASE Hexagonal	Green. Transparent.	Double 1.655-1.708	5	3.30	Emerald.
DUMORTIERITE Orthorhombic	Violetish-blue, blue, greenish-blue. Translucent. Sometimes impregnates and colors quartz.	Double 1.68-1.69	7	3.30	Lapis lazuli.
EUCLASE Monoclinic	Colorless, light blue or green. Transparent.	Double 1.65-1.67	7½	3.10	Aquamarine; topaz; sapphire; glass.
FELDSPAR GROUP					
ALBITE-OLIGOCLASE Triclinic	Colorless. Translucent.	Double 1.53-1.55	6-6½	2.64	White quartz.
Moonstone	Red spangled. Translucent.				Glass (<i>goldstone</i>).
Suzstone	Green or red spangled. Translucent.				Aventurine quartz.
Aventurine	Gray, blue, bluish-green. Translucent.	Double 1.559-1.566	6	2.70	No imitations.
LABRADORITE Triclinic	Gray, blue, bluish-green. Translucent.	Double 1.522-1.530	6-6½	2.56	
MICROCLINE Triclinic	Yellowish-green, green, bluish-green. Translucent.	Double 1.52-1.53	6-6½	2.56	Jade.
Amazonite	Colorless, gray, bluish-gray, yellow. Transparent to translucent.				Quartz; topaz.
ORTHOCLASE Monoclinic	Gray, bluish-gray, white. Translucent.				White quartz; glass.
Adularia or Precious Moonstone	Colorless, red, blue, green, brown, gray, yellow, etc. Transparent to translucent.	Single 1.434	4	3.18	Amethest; aquamarine; green beryl; topaz; topaz quartz; spinel; and most transparent gemstones.
FLUORITE Cubic					

HANDBOOK OF GEM IDENTIFICATION

Name and Crystal System	Color and Transparency	Average Refractive Indices	Hardness	Gravity Specific	In Appearance May Be Confused With
GARNET GROUP— Cubic					
ALMANDINE	Red to purple-red, transparent to translucent.	Single 1.79	7½	4.05	Ruby; spinel; some amethyst; synthetic ruby or spinel; doublet; glass.
ANDRADITE	Yellow. Transparent.	Single 1.885	6½-7	3.84	Topaz.
<i>Dematoid</i>	Green. Transparent.				Emerald; peridot; chrysoberyl; zircon; fluorite; glass.
<i>Melanite</i>	Black. Opaque.				Black onyx; black jade.
GROSSULARITE	White, yellow, brown, green. Transparent to translucent.	Single 1.745	7	3.61	Green or white jadeite; white nephrite
<i>Hessonite</i>	Orange-brown to yellow-brown. Transparent.				Topaz; topaz quartz; sapphire; zircon; glass; doublet.
PYROPE	Red. Transparent to translucent.	Single 1.75	7-7½	3.78	Ruby; spinel; synthetic ruby; doublet; glass.
RHODOLITE (Mixture of almandite and pyrope)	Rose-red to purple. Transparent.	Single 1.76	7-7½	3.84	Spinel; pink sapphire; tourmaline; synthetic pink sapphire; amethyst; glass.
SPESSARTITE	Orange-red, orangy-yellow, brownish-red. Transparent.	Single 1.80	7-7½	4.15	Quartz; topaz.
GLASS Amorphous	Colorless or any color. Transparent to translucent.	Single 1.48-1.70 or higher. Variable.	5	1.3-4.5 Variable.	Almost any gemstone.
GYPSUM Monoclinic <i>Satin spar</i>	Colorless, white. Transparent to translucent. Silky white, yellow, brown, pink.	Double 1.52-1.53	2	2.32	No imitation.
HEMATITE Hexagonal	Black. Opaque.	Opaque.	5-6½	5.1	Cat's-eye. Hemite; steel; monel metal; glass.

Property Tables of Gemstones and Their Substitutes

Name and Crystal System	Color and Transparency	Average Refractive Indices	Hardness	Specific Gravity	In Appearance May Be Confused With
HEMETINE	A black opaque composition.	Opaque.	2½-5½	4-7	Hematite; steel; monel metal.
IDOCRASE Tetragonal <i>Californite</i>	Light to dark green or yellowish-green. Translucent.	Double 1.713-1.718	6½	3.40	Jadeite; nephrite.
JADE JADEITE Monoclinic	Green, bluish-green, red, white. Semitransparent to opaque.	Double 1.60-1.68	6½-7	3.34	Nephrite; amazonite; idocrase; grossularite; talc; serpentine; quartz; sillimanite; prehnite glass.
NEPHRITE Monoclinic	White, gray, green, yellow, red, blue-green. Translucent to opaque.	Double 1.61-1.63	6-6½	2.95	Amazonite; jadeite; grossularite; idocrase; talc; serpentine; quartz; sillimanite; prehnite; glass.
JET	Black. Opaque.	Opaque.	2½-4	1.30	Glass; plastics; rubber.
KORNERUPINE Orthorhombic	Colorless, light green and brown. Transparent.	Double 1.665-1.677	6½	3.30	Beryl; topaz; tourmaline.
KYANITE Triclinic	Blue, green, brown, colorless. Transparent to translucent.	Double 1.712-1.728	4-7	3.60	Corundum; spinel.
LAZULITE Monoclinic LAZURITE Cubic <i>Lapis lazuli</i>	Blue. Translucent.	Double 1.61-1.64	5-6	3.09	Lazurite; fluorite.
LUCITE (Plastic) Amorphous	Intense blue to light blue. Semitranslucent to opaque.	Single 1.50	5-6	2.75	Lazurite; dyed jasper quartz; aggregate of dumortierite and quartz.
MALACHITE Monoclinic	Colorless or any color. Transparent.	Single 1.49	2½	1.19	Many transparent gems.
	Green. Semitranslucent to opaque.	Double 1.66-1.91	3½-4	3.95	No imitations.

HANDBOOK OF GEM IDENTIFICATION

Name and Crystal System	Color and Transparency	Average Refractive Indices	Hardness	Specific Gravity	In Appearance May Be Confused With
MARCASITE Orthorhombic	Pale brownish-yellow. Opaque.	Opaque.	6-6½	4.80	Pyrite.
MOLDAVITE Amorphous	Light to dark green, yellowish-green. Transparent to translucent.	Single 1.48	5½	2.40	Peridot; demantoid garnet; emerald; beryl; fluorite.
OBSIDIAN Amorphous	Colorless, varicolored, black. Transparent to opaque.	Single 1.45	5-5½	2.45	Onyx; cairngorm; glass.
OPAL Amorphous	Precious varieties are colorless, white, black, various colors. Transparent to translucent, and with play of color.	Single 1.45	5-6½	2.15	Opal doublet; glass.
PEARL	White, gray, black, light tones of red, yellow, green, blue. Translucent to opaque.	About 1.60	2¼-4	2.7	Cultured pearl; wax-filled or solid glass imitations.
<i>Cultured pearl</i>	Outer layers true pearl. Inner portion is mother-of-pearl bead.			2.75	Pearl; wax-filled or solid glass imitations.
PERIDOT Orthorhombic	Yellowish-green, green, dark green, brown. Transparent to translucent.	Double 1.659-1.697	6½-7	3.40	Demantoid garnet; emerald; tourmaline; zircon; chrysoberyl; sapphire; etc.; moldavite; glass.
PHENACITE Hexagonal	Colorless, light red, yellow, brown. Transparent.	Double 1.654-1.670	7½-8	2.95	Beryl; spodumene; topaz.
PREHNITE Orthorhombic <i>Chlorastrolite</i>	Light green to yellowish or grayish-green. Translucent. A translucent mottled green prehnite or related mineral with a chatoyant effect.	Double 1.62-1.65	6-6½	2.9	Jadeite; nephrite.
PYRITE Cubic	Pale brassy yellow. Opaque.	Opaque.	6-6½	5.0	Jade. Marcasite.

Property Tables of Gemstones and Their Substitutes

Name and Crystal System	Color and Transparency	Average Refractive Indices	Hardness	Specific Gravity	In Appearance May Be Confused With
QUARTZ Hexagonal		Double 1.54-1.55	7	2.65	
CRYSTALLINE VARIETIES— Rock Crystal	Colorless. Transparent.				Diamond; sapphire; topaz; beryl; other colorless stones; glass.
Amethyst	Purple, violet. Transparent.				Apatite; fluorite; some garnets; tourmaline; natural or synthetic sapphire; natural or synthetic spinel; apodumene (kunzite). Tourmaline; fluorite.
Rose quartz	Pink, rose-red. Semi-transparent to translucent.				Obsidian; tourmaline; glass.
Smoky quartz	Smoky brown. Transparent.				Topaz; hessonite; beryl; sphene; tourmaline; zircon; natural or synthetic sapphire; fluorite; glass.
Citrine	Yellow. Transparent.				Aventurine feldspar; glass (goldstone); jade.
Aventurine	Yellow, brown, green, red, spangled with metallic flakes. Translucent.				No imitations.
Tiger-eye	Fibrous, chatoyant, brown, blue, red. Translucent.				Cat's-eye chrysoberyl; cat's-eye tourmaline.
Cat's-eye	Fibrous, chatoyant, gray brown, green. Translucent				
CRYPTOCRYSTALLINE VARIETIES	(All cryptocrystalline varieties of quartz are the sub-species of quartz known as CHALCEDONY.)	1.535-1.539	7	2.61	
Chalcedony	White, gray, light blue, black. Semitransparent to translucent.				Moonstone (feldspar); glass.
Carnelian	Red, orange-red. Translucent.				Dyed onyx, marble; glass.

HANDBOOK OF GEM IDENTIFICATION

Name and Crystal System	Color and Transparency	Average Refractive Indices	Hardness	Specific Gravity	In Appearance May Be Confused With
<i>Chrysoprase</i>	Light yellowish-green. Translucent.				Jade; glass.
<i>Bloodstone</i>	Dark green with red spots. Semitranslucent				No imitations.
<i>Moss agate</i>	White or light gray with dark, dendritic inclusions. Semitransparent to translucent.				No imitations.
<i>Agate</i>	Varicolored. Banded; curved bands. Translucent.				Onyx marble.
<i>Onyx</i>	Varicolored. Banded; straight bands. Translucent to semitranslucent.				Doublets; glass.
"Black onyx"	Chalcedony dyed black. Opaque.				Black jade; melanite garnet.
<i>Sardonyx</i>	Alternate red-brown and white bands. Translucent to semitranslucent.				Doublets; glass.
<i>Jasper</i>	Red, yellow, brown, dark green, grayish-blue. Semitranslucent.				Pottery or glass imitations only.
RHODONITE Triclinic	Medium red (flesh red). Opaque to transparent.	Double 1.733-1.744	5½-6½	3.53	Coral.
SCAPULITE (A group)	Colorless, yellow, pink, greenish or bluish gray. Transparent to semitransparent. May be chatoyant.	Double 1.544-1.556 1.553-1.574	5½-6 5½-6	2.60 2.72	Beryl; tourmaline; topaz.
Tetragonal SERPENTINE Monoclinic	An alteration product of other minerals. Properties variable, depending on the degree of completeness of alteration.				
<i>Precious serpentine</i>	Green to yellowish-green. Semitranslucent.	Double 1.50-1.55	2½-4	2.5-2.6	Jade.
<i>Bouenite</i>	Green. Semitranslucent.	Double 1.50-1.55	5-6	2.6 2.8	Jade; quartz.

Property Tables of Gemstones and Their Substitutes

Name and Crystal System	Color and Transparency	Average Refractive Indices	Hardness	Specific Gravity	In Appearance May Be Confused With
SILLIMANITE Orthorhombic	Grayish-white, grayish-green, brownish-green. Translucent to opaque.	Double 1.66-1.68	6-7	3.24	Jadeite; nephrite.
SMITHSONITE Hexagonal	White, yellow, green, blue. Translucent to opaque.	Double 1.62-1.85	5	4.30	Jadeite; nephrite.
SPHENE Monoclinic	Usually yellow to brown. green. Transparent.	Double 1.900-2.034	5-5½	3.52	Zircon; garnet; topaz; beryl; citrine; glass.
SPINEL Cubic	Red, pink, yellow, orange-red, violet, purple, blue, green. Transparent.	Single 1.726	8	3.60	Ruby; sapphire; amethyst; garnet; zircon; synthetic corundum; synthetic spinel; glass.
SPODUMENE Monoclinic <i>Hiddenite</i>	Colorless to yellow. Transparent.	Double 1.660-1.676	6-7	3.18	Citrine quartz; topaz; beryl; glass.
<i>Kunzite</i>	Green to yellowish-green. Transparent.				Emerald; peridot; chrysoberyl; sapphire; synthetic corundum and spinel.
	Light red to light purple. Transparent.				Tourmaline; spinel; topaz; rose quartz; beryl; synthetic corundum and spinel.
TALC Monoclinic	Gray to grayish-green. Translucent to opaque. Also known as <i>sapstone</i> and <i>steatite</i> .	Double 1.54-1.59	1-1½	2.75	Jadeite; nephrite.
TOPAZ Orthorhombic	Colorless, yellow, red, green, blue. Transparent.	Double 1.619-1.627	8	3.53	Quartz; tourmaline; garnet; spodumene; beryl; sapphire; etc.; synthetic corundum; synthetic spinel; doublet; glass.
TOURMALINE Hexagonal	Light to dark greenish-yellow, green, yellowish-green, blue, colorless. Transparent.	Double 1.624-1.644	7-7½	3.06	Emerald; peridot; topaz; corundum; chrysoberyl; etc.; synthetic corundum and spinel; glass.
<i>Rubellite</i>	Light red to red-purple. Transparent.				Topaz; kunzite spodumene; spinel; corundum; beryl; glass.

HANDBOOK OF GEM IDENTIFICATION

Name and Crystal System	Color and Transparency	Average Refractive Indices	Hardness	Specific Gravity	In Appearance May Be Confused With
TURQUOISE Triclinic	Blue to blue-green. Translucent to opaque.	Double 1.61-1.65	5-6	2.76	Variscite; glass.
VARISCITE Orthorhombic	Yellowish-green to blue-green. Translucent to opaque.	Double 1.56-1.59	4-5	2.50	Turquoise.
WILLEMITE Hexagonal	Yellow, green, red, brown. Transparent to translucent.	Double 1.69-1.72	5½	4.6	Peridot; beryl.
ZIRCON Tetragonal Low	Green. Transparent.	Double (weak) 1.81-1.82	6	4.00	Garnet; chrysoberyl; corundum; spinel; peridot; sphen; tourmaline; diamond; beryl; topaz; quartz; synthetic corundum; synthetic spinel; glass.
High	Colorless, yellow, blue, red. Transparent.	Double (very strong) 1.92-1.98	7½	4.70	
Intermediate	Green, yellow, brown. Transparent.	Other properties variable between low and high.			
ZOISITE Orthorhombic Saussurite	Colorless, gray, green, pink. Transparent to translucent. Gray, greenish-gray to yellowish-green mixture of zoisite and feldspar.	Double 1.70-1.71	6-6½	3.12	Jade.

Short Glossary of Gemological Terms

- Amorphous.** Without form. Material that has no regular arrangement of atoms, hence no crystal structure.
- Anisotropic.** Possessing the property of double refraction. See Chapter VI.
- Asterism.** A term applied to the display of a rayed figure (star) by a gemstone when cut en cabochon.
- Atom.** The smallest portion of an element which retains the properties of that element.
- Atomic weight.** The weight of an atom of an element compared to the arbitrary figure, 16 assigned to an atom of oxygen.
- Biaxial.** Possessing two optic axes—two axes of single refraction in a doubly refractive substance. Gems in the orthorhombic, monoclinic and triclinic crystal systems are biaxial. See Chapter VI.
- Birefringence.** The strength of double refraction measured by taking the difference between the high and low indices of a doubly refractive stone. See Chapter VI.
- Boule.** The rough form of synthetic corundum and spinel. Pear or carrot shaped. See page 103.
- Brilliant.** A gem cut in the brilliant form (the common round diamond cut), with the table and 32 facets on the crown, and 24 facets plus the culet on the pavilion.
- Cabochon.** A facetless cutting style that produces convex surfaces.
- Carat.** Unit of weight equal to 200 milligrams.
- Chatoyancy.** Optical phenomenon, displayed by certain gems, that produces a thin bright line across a stone cut en cabochon. Cat's-eye effect.
- Conchoidal.** Type of fracture commonly seen in gems and glass. Break resembles a clam-shell surface. See page 9.
- Critical angle.** Largest angle measured from the normal at which light can escape from an optically dense substance and the smallest angle to the normal at which light is totally reflected within the dense substance. See Chapter V.
- Cryptocrystalline.** Having crystals so small that individual crystals cannot be resolved by an ordinary microscope, but detectable by effect on polarized light.
- Crystal system.** One of the six groups of crystal patterns in which minerals and other crystalline solids occur.
- Crystal.** Material with regular arrangement of atoms bounded by natural plane surfaces.
- Cubic.** See isometric.
- Density.** Mass per unit volume. See Chapter IV.
- Diamondscope.** Trademark name for a binocular microscope mounted on a patented dark-field illuminator base. See Chapter VII.
- Dichroism.** Unequal absorption of the two portions of a doubly refracted beam of light, producing two colors when observed through a dichroscope.
- Dichroscope.** A small instrument for gem testing that is used to detect pleochroism. See page 48.

HANDBOOK OF GEM IDENTIFICATION

- Dispersion.** The separation of white light into its component colors.
- Double refraction.** The property of separating a single light ray into two. See Chapter II.
- Doublet.** An imitation gem composed of two pieces of gem material or one of gem material and a second of glass cemented together.
- Doubling of the back facets.** Facet edges seen twice (as parallel lines) when seen through a strongly doubly refractive gem.
- Emerald filter.** A color filter through which imitations appear green, and emerald, synthetic emerald and some other genuine gems have a reddish color. See Chapter IX.
- Extinction.** Position of darkness in a transparent anisotropic gem when examined in crossed polarized light. See page 46.
- Fire.** See dispersion.
- Fluorescence.** The emission of visible light by a gem when subjected to ultra-violet or X-radiation.
- Fracture.** A break other than in a cleavage direction. Usually shell-like in gems. See Chapter III.
- Gemo'ite.** Trade-mark name for a monocular microscope mounted on a patented illuminator base. See Chapter VII.
- Habit.** The crystal form in which a mineral most often occurs; i.e., habit of diamond is the octahedron.
- Hardness.** Resistance a material offers to scratching or abrasion. See Chapter III.
- Hardness points or pencils.** Points made from gem materials for hardness determination. Hardnesses of 9, $8\frac{1}{2}$, 8, 7, 6, $6\frac{1}{2}$ are common, with some sets including 10, $7\frac{1}{2}$, 5. See Chapter III.
- Hexagonal.** A crystal system (three equal axes at 60 degrees, a fourth perpendicular to the other three and unequal in length). Examples: quartz, corundum, beryl and tourmaline.
- Imperfection.** Any surface or internal flaw or inclusion in a gem.
- Inclusion.** Internal imperfection other than fracture or cleavage in a gem.
- Inorganic.** Any substance not produced through the agency of living organisms.
- Interference.** Effect produced of two or more light waves traveling the same path after traveling different distances. If they are "in phase," they will reinforce each other (intensify the color). If they are out of phase, they will destroy each other. Interference of white light results in destruction of certain wave lengths and reinforcement of others; producing such effects as the play of color in opal.
- Iridescence.** Light interference effect in thin films of gas or liquid causing rainbow effects.
- Isometric.** Crystal system of highest symmetry with three equal crystallographic axes at right angles. Gems which crystallize in the isometric system are diamond, spinel and the garnet group.
- Liquid inclusion.** Space within a substance filled or partially filled with a liquid. See Chapter VIII.
- Luster.** The appearance of a gem. More specifically, the quality and

Short Glossary of Gemological Terms

quantity of light reflected by a gem. Luster usually refers to the appearance of the surface.

Methylene iodide. An organic liquid used in gem testing. R. I. 1.74, S.G. 3.32.

Mineral. A natural inorganic material with a characteristic composition and crystal structure.

Mohs Scale. An arbitrary scale of hardness with numbers from one to ten assigned to ten minerals of increasing hardness from talc to diamond. See page 10. See Chapter III.

Monochromatic. Possessing a single color.

Monochromatic Unit. A source of monochromatic light for refractive index determination. See Chapter IV.

Monoclinic. A crystal system of low symmetry. Jade, spodumene and orthoclase feldspar are monoclinic.

Opaque. Transmitting no light, even through thin edges.

Optic axis. A direction of single refraction in a doubly refractive substance. See Chapter VI.

Organic. Formed by a living organism—plant or animal.

Orthorhombic. A crystal system of fairly low symmetry. Described by three crystal axes at right angles, but unequal in length. Gems which crystallize in the orthorhombic system are topaz and peridot.

Orient. The iridescent luster of a pearl.

Paste. A name commonly applied to glass imitations. Used less often for other imitations. See Chapter XI.

Plastic. A manufactured organic product often used to imitate gems (especially amber) in costume jewelry.

Pleochroism. Unequal absorption of the two portions of a doubly refracted beam of light producing two or more colors when observed through a dichroscope.

Polariscope. A gem testing instrument employing two pieces of Polaroid to determine single and double refraction, pleochroism and interference figures. See Chapter VI.

Polarized light. Light waves vibrating in a single plane. See Chapter VI.

Polaroid. Trade-mark name for a material which effectively polarizes light.

Radiograph. A photograph of an object in the path of a broad X-ray beam.

Reconstructed. Term applied in gemology to gems made by sintering small pieces of the natural gem.

Reflection. Rebound from a surface. Light which strikes a reflecting surface is reflected at the same angle to the normal as the angle of incidence. See Chapter V.

Refraction. The bending of light rays as they pass from one medium to another of different optical density at angles other than perpendicular to their boundary. See Chapter V.

Refractive index. The ratio of the velocity of light in air to its velocity in a substance. See Chapter V.

- Refractometer.** An instrument that measures refractive index. See Chapter VI.
- Silk.** Term commonly applied to long needle-like crystal inclusions in natural ruby and sapphire.
- Spectroscope.** An optical instrument used for forming spectra.
- Spectrum.** The images formed when a beam of light (visible or otherwise) is dispersed and then brought to focus.
- Specific gravity.** The ratio of the weight of a substance to that of an equal volume of water at 4 degrees Centigrade. See Chapter IV.
- Synthetic.** A man-made substitute possessing the same chemical composition, crystal structure, and thus the same properties as the gem it represents. See Chapter X.
- Tetragonal.** A crystal system to which may be assigned two crystallographic axes equal in length and at right angles with a third at at right angles to the first two. Zircon and idocrase are gems which occur in the tetragonal system.
- Transparent.** Transmitting light with a minimum of distortion.
- Translucent.** Transmitting light, but diffusely. Example: frosted glass.
- Triclinic.** The least symmetrical crystal system. Turquoise and most feldspars occur in this system.
- Ultra-violet.** That portion of the electromagnetic spectrum just shorter in wave length than visible violet light.
- Uniaxial.** Doubly refractive material with but one optic axis (direction of single refraction). Materials which crystallize in the hexagonal or tetragonal crystal systems.
- X-rays.** Radiation of .5 to 2.0Å. propagated in a cathode tube by bombarding a copper, tungsten or other metal target with a stream of electrons. Useful because of their remarkable ability to penetrate almost any material. X-ray diffraction patterns from a given material serve to identify the material.

Index

A

Acetone, 62.
Adamantine luster, 149, 156, 166, 177, 198, 209, 221.
Adularia, 263.
Agate, see chalcedonic quartz, agate.
Alcohol, 62.
Alexandrite, chrysoberyl, 154, 175, 186, 261.
Alexandrite, trichroism in, 159, 182.
Almandite garnet, 80, 81, 154, 238, 264.
Almandite garnet, characteristic inclusions of, 80, 81.
Almandite garnet, star garnet, 238.
Amazonite, microcline feldspar, 229, 263.
Amber, 3, 186, 196, 238, 260.
American Optical Company, 144, 145.
Amethyst, see quartz, amethyst.
Amorphous, 3, 41.
Amorphous substances, 3-5.
Analyzer, 53.
Andalusite, 154, 155, 175, 176, 207, 260.
Andalusite, dichroism in, 159, 182.
Anderson, B. W., 28, 132, 133.
Andradite garnet, demantoid, 82, 175, 264.
Andradite garnet, demantoid, characteristic inclusions of, 82.
Andradite garnet, melanite, 245, 264.
Angle of incidence, 25, 27.
Angle of reflection, 25.
Angle of refraction, 27.
Angstrom units, 41, 100, 122, 123.
Anisotropic, 42.
Anomalous double refraction, polariscope test for, 46, 113.
Anomalous double refraction, spinel, in, 113, 159, 169, 180, 184, 190, 194, 201, 204, 213, 217, 223, 226.
Apatite, 165, 186, 260.
Apparent depth method for refractive index, 37.
Appearance, cultured pearls, of, 113.
Aquamarine, see beryl, aquamarine.
Aragonite, 129.
Archimedes, 16.
Arrangement, text, of, 1, 2.
Assembled stones, 69, 120-124.
Assembled stones, classification of, 121.
Assembled stones, identification of, 69.
Assembled stones, types commonly encountered, 121.
Asterism, six-rayed star, 166, 229, 238, 245.
Asterism, star sapphire, see corundum, star sapphire.
Asterism, star garnet, see almandite garnet, star garnet.
Atomic weight, 15.
Aventurine quartz, 229, 267.
Axinite, 260.
Azurite, 229, 260.

B

Back facets, molded, 126, 156, 166, 177, 188, 210, 240, 247.
Bakelite, 128, 154, 164, 175, 186, 196, 207, 219, 229, 238, 245, 260.
Balances, specific gravity, 16-19.
Bausch and Lomb Optical Company, 144, 145.
Beck Hand Spectroscope, 146.
Benitoite, 164, 260.
Benitoite, dichroism in, 169.
Benson, Lester B., Jr., Preface.
Berman Balance, 20.
Beryl, 4, 8, 10, 14, 70, 83, 84, 154, 164, 175, 186, 196, 207, 219, 260.
Beryl, aquamarine, 164, 260.
Beryl, aquamarine, dichroism in, 5, 6, 170.
Beryl, brown and orange, 196.
Beryl, characteristic inclusions of, 83.
Beryl, emerald, 8, 83, 117, 118, 175, 261.
Beryl, emerald, dichroism in, 181.
Beryl, goshenite, 219, 260.
Beryl, morganite, 154, 207, 261.
Beryllonite, 219, 261.
Binocular microscope, see microscope.
Birefringence, 42, 43.
Birefringence, table of, 42, 254.
Black onyx, see chalcedonic quartz, black onyx.
Black opal, 164, 229, 245, 266.
Black welts, cultured pearls, 133.
Black, white and gray nontransparent gemstones and substitutes, identification of, 245-252.
Bloodstone, chalcedony, 229, 268.
Blue transparent gemstones and substitutes, identification of, 164-174.
Blue and green gemstones and substitutes, nontransparent, 229-237.
Blue sheen in reflected light as clue to identification, 221, 247.
Bordeaux tourmaline, see tourmaline, bordeaux.
Boule, 103, 104, 111.
Brazilianite, 261.
Bromoform, 22, 67, 132, 157, 168, 179, 190, 200, 211, 222.
Bromoform, refractive index, 67.
Bromoform, specific gravity, 21, 22, 132.
Brown and orange transparent gemstones and substitutes, identification of, 196-206.
Brown, red and yellow nontransparent gemstones and substitutes, identification of, 238-244.
Bubbles, glass detection, in, 127.
Bubbles, spherical, 127, 156.
Bubbles, synthetic detection, in, 127.
Burma ruby, color distribution of, 77, 110.

HANDBOOK OF GEM IDENTIFICATION

C

- Cabochon cut, refractive index, from, 35, 38.
- Cairngorm quartz, see quartz, cairngorm.
- Calcite, 3, 43.
- Calcite, birefringence of, 43.
- Candling, pearl test, 132, 133.
- Carbon tetrachloride, 18, 62.
- "Carbona," specific gravity, use in, 18, 19, 128.
- Carnelian, see chalcedonic quartz, carnelian.
- Cassiterite, 261.
- Cat's-eye, 175, 186, 229, 238, 261.
- Cat's-eye, chrosoberyl, 175, 186, 229, 238, 261.
- Ceylon ruby, 208.
- Chalcedonic quartz, 9, 164, 175, 186, 196, 207, 219, 229, 238, 245, 268.
- Chalcedonic quartz, agate, 245, 268.
- Chalcedonic quartz, black onyx, 245, 268.
- Chalcedonic quartz, bloodstone, 229, 268.
- Chalcedonic quartz, carnelian, 196, 238, 268.
- Chalcedonic quartz, cat's-eye, 175, 186, 229, 238, 268.
- Chalcedonic quartz, chalcedony moonstone, 219, 245, 268.
- Chalcedonic quartz, chrysocolla, 229, 268.
- Chalcedonic quartz, chrysoprase, 172, 229, 268.
- Chalcedonic quartz, dyed chalcedony, 229, 268.
- Chalcedonic quartz, fracture, 9.
- Chalcedonic quartz, gray, 245, 268.
- Chalcedonic quartz, sard, 207, 238, 268.
- Chalcedonic quartz, sardonyx, 207, 238, 268.
- Chalcedonic quartz, white, 245, 268.
- Chalcedony, see also chalcedonic quartz.
- Chalcedony, fracture of in identification, 74.
- Chalcedony, moonstone, 219, 245, 267.
- Characteristic inclusions, synthetic gemstones, 91-96, 105-119.
- Characteristic inclusions, test for determination of unknown gems, 71-96.
- Chatham, Carroll, 117.
- Chelsea filter, see emerald filter.
- Chromatic aberration, 56.
- Chrosoberyl, 4, 154, 175, 186, 196, 207, 229, 238, 261.
- Chrosoberyl, alexandrite, 154, 175, 207, 261.
- Chrosoberyl, brown and orange, 196, 238, 261.
- Chrosoberyl, cat's-eye, 175, 186, 229, 238, 261.
- Chrosoberyl, cleavage of, 74, 75.
- Chrosoberyl, crystal structure, 4.
- Chrysocolla, see also chalcedonic quartz, 230, 268.
- Chrysoprase, see chalcedonic quartz, chrysoprase.
- Cinnamon oil, index, 67.
- Citrine quartz, 186, 267.
- Cleaning a gemstone, 62, 63.
- Cleavage, 8, 74.
- Cleavage, defined, 8.
- Cleavage, false (parting), 8.
- Cleavage, gem identification, in, 8, 74.
- Clerici's solution, 22.
- Coated back on a star stone, 124, 166, 210.
- Color banding, 240.
- Color change from daylight to artificial light, 155, 177, 209.
- Color difference, assembled stone, in, 209.
- Color filter, 97, 98.
- Color fringe, 57.
- Color variations, 4.
- Colored gems under magnification, 66, 71-96.
- Colorless gemstones and substitutes, identification of, 219-228.
- Conchiolin, defined, 129.
- Conchiolin welts, 133.
- Conchoidal fracture, 9, 74.
- Content of text, I, 2.
- Copal, 196.
- Coral, 3, 238, 261.
- Cordierite, see iolite.
- Corundum, 4, 10, 69, 75-79, 106, 107, 109-111, 154, 164, 175, 186, 196, 207, 219, 229, 238, 245, 262.
- Corundum, appearance of repeated twinning in, 79.
- Corundum, brown and orange, 196, 262.
- Corundum, characteristic inclusions of, 75-79.
- Corundum, detection of flaws in, 69, 70, 75-79, 106, 107, 109, 110.
- Corundum, detection by immersion, 69.
- Corundum, false cleavage in, 9, 79.
- Corundum, padparadsha, 196, 262.
- Corundum, ruby, 4, 207, 262.
- Corundum ruby, crystal structure, 4.
- Corundum, sapphire, 4, 42, 69, 70, 106, 107, 109-111, 154, 175, 186, 196, 207, 219, 229, 238, 245, 262.
- Corundum, green sapphire, 175, 262.
- Corundum, pink sapphire, 207, 262.
- Corundum, star sapphire, 229, 238, 245, 262.
- Corundum, white sapphire, 219, 262.
- Corundum, star ruby, 207, 238, 262.
- Corundum, synthetic, see synthetic corundum.
- Critical angle, 26-28.
- "Cross-hatched," 113-114, 159, 169, 180, 190, 201, 213, 223.
- Crystal structure, 5.
- Crystal systems, function in determinations, 4, 5, 42.
- Crystal systems, hexagonal, 4, 42.
- Crystal systems, importance of knowing, 4, 5.
- Crystal systems, isometric (or cubic), 4, 5, 42.
- Crystal systems, monoclinic, 4, 42.
- Crystal systems, orthorhombic, 4, 42.
- Crystal systems, in rough gems, how to determine, 5.
- Crystal systems, tetragonal, 4, 42.
- Crystal systems, triclinic, 4, 42.
- Crystalline aggregates, doubly refractive, 47.
- Cultured pearl, defined, 130, 266.
- Cultured pearl, detection of, 130-140.
- Curved striae, 92, 108.

Index

D

- Danburite, 262.
Dark-field illumination, 56, 73, 113.
Demantoid, see andradite garnet, demantoid.
Density, defined, 15.
Density, diamond, 5.
Density, graphite, 5.
Density, specific gravity and, 15-21.
Determination, minerals, properties of, 4, 5.
Diamond, 4, 8, 10, 14, 21, 24, 29, 55, 74, 89, 90, 154, 164, 175, 186, 196, 207, 219, 245, 262.
Diamond balance, specific gravity, for, 16-19.
Diamond, blue, 164, 262.
Diamond, brown, 196, 262.
Diamond, characteristic inclusions of, 90.
Diamond, cleavage of, 8, 74, 75.
Diamond, crystal structure of, 4, 5.
Diamond, density of, 5.
Diamond, dispersion, 155, 164, 166, 177, 188, 198, 209, 221.
Diamond, green, 175, 262.
Diamond imperfection detector, 59, 144.
Diamond, luster, 166, 177.
Diamond, red, 207, 262.
Diamond, specific gravity, 24.
Diamondscope, 58, 59, 144.
Dichroism, 47, 48, 159, 169, 170, 180, 181, 191, 201, 213.
Dichroism, andalusite, in, 159, 180, 181.
Dichroism, apatite, in, 169.
Dichroism, benitoite, in, 168, 169.
Dichroism, beryl, in, 170, 180, 181, 190.
Dichroism, beryl, aquamarine, in, 170.
Dichroism, beryl, emerald, in, 180, 181.
Dichroism, beryllonite, in, 190, 191.
Dichroism, blue gemstones, in, 169, 170.
Dichroism, brown and orange gemstones, 201.
Dichroism, corundum, in, 159, 169, 180, 190, 191, 201, 213.
Dichroism, dyed quartz, in, 170.
Dichroism, euclase, in, 170.
Dichroism, green gemstones, in, 181.
Dichroism, identification, in, 47, 48, 159, 169, 170, 180, 190, 191, 201, 213.
Dichroism, iolite, in, 168, 169.
Dichroism, orthoclase, in, 190, 191.
Dichroism, peridot, in, 180, 190, 191.
Dichroism, phenacite, in, 190, 191.
Dichroism, purple and violet gemstones, in, 159.
Dichroism, quartz, in, 190, 191.
Dichroism, sapphire, in, 159, 169, 191.
Dichroism, sphene, in, 180, 181, 190, 191.
Dichroism, spodumene, kunzite, in, 160, 213.
Dichroism, synthetic gemstones, in, 111, 158, 169, 191.
Dichroism, test for, 47, 48, 159, 169, 170, 180, 181, 191, 201, 213.
Dichroism, topaz, in, 168, 180, 181, 190, 201.
Dichroism, tourmaline, in, 168, 180, 181, 190, 201.
Dichroism, yellow gemstones, in, 190, 191.
Dichroism, zircon, in, 168, 169, 180, 190.
Dichroscope, 48, 49, 144, 159, 168, 169, 170, 181, 190, 191.
Dichroscope, double refraction, for, 49.
Dichroscope, pleochroism, for, 49.
Diffusion column, 23.
Diopside, 262.
Dioptrase, 263.
Direct reading balances, 21.
Dispersion, strong, in identification, 155, 166, 177, 188, 198, 210, 221.
Double images, 155, 166, 178, 188, 198, 210, 221.
Double-mirror method, 136.
Double refraction, 41-54, 69, 70.
Double refraction, birefringence and, 69, 70.
Double refraction, detection of, 43-47, 69, 70.
Double refraction, determination under magnification, 43.
Double refraction, effect of repeated twinning on appearance of, 47.
Double refraction, pleochroism and optic character, 41-54.
Double refraction, reflection test for, 44.
Double refraction, test for, in polariscope, 44-47.
Doublet, 69, 101, 120-124, 155, 165, 176, 187, 197, 209, 220, 231, 246.
Doublet, detection of, 69, 101, 121-124.
Doublet, garnet-and-glass, 101, 121-124, 155, 165, 176, 187, 197, 209, 220.
Doublet, immersion test to detect, 69, 122.
Doublet, luster test, 122.
Doublet, magnification test for, 123, 124.
Doublet, opal, 121, 233.
Doubling of back facet edges, 43, 69, 155, 166, 178, 188, 198, 210, 221.
Doubly refractive, crystalline aggregates, appearance in polariscope, 47.
"Dreft," 18.
Drop of water test, 127.
Dumortierite, 263.
Dust, inclusions and, 65.

E

- Eliminative testing method, 148-152.
Emerald, see beryl, emerald.
Emerald, Colombian, 83, 117, 118, see also beryl, emerald.
Emerald filter 97, 98, 146, 181.
Emerald, Russian, 83, 118, see also beryl, emerald.
Emerald, synthetic, see synthetic emerald.
Erb and Gray Refractometer, 30-32, 141.
"Essence d'orient," 139.
Euclase, 165, 220, 263.
Even fracture, 9.
Eye loupe, 55-57, 63, 144.

F

- False cleavage (parting), 8, 9.
False doublet, 121, 122.
Feldspar, 4, 8, 74, 164, 186, 219, 229, 245, 263.
Feldspar, cleavage, 8, 74.
Feldspar, labradorite, 4, 164, 229, 245, 263.
Feldspar, microcline, amazonite, 229, 253.
Feldspar, orthoclase, moonstone, 4, 219, 245, 263.

HANDBOOK OF GEM IDENTIFICATION

Filter, color, see emerald filter.
Filter, emerald, see emerald filter.
Fingerprint inclusions, corundum, in, 78, 107.
Fire, see dispersion.
Fire opal, 196, 207, 266.
Flashes of red from dark sapphire-blue gem, 166.
Flow lines, glass, in, 95, 127.
Fluorescence, 99-101, 115, 119, 122, 123, 145, 146, 182.
Fluorescence test, 99-101, 115, 119, 122, 123, 182.
Fluorescent unit, 100, 145, 146, see also G.I.A. Fluorescent Unit.
Fluorite, 154, 156, 164, 166, 175, 177, 207, 210, 263.
Fluorite, luster, 156, 166, 177, 210.
Focusing microscopes, 64.
Foil back, 120, 121, 124, 164, 186, 207, 229, 238.
Foil back, star quartz, 121, 124, 165, 209, 231, 239.
Four-rayed star, 240.
Fracture, 9, 74.
Fracture, conchoidal or "shell-like," 9, 74.
Fracture, defined, 9.
Fracture, even, 9.
Fracture, identification by, 9, 74.
Fracture, splintery, 9, 74.
Fracture, uneven, 9.

G

Garnet, almandite, see almandite garnet.
Garnet, andradite, see andradite garnet.
Garnet-and-glass doublet, see doublet, garnet-and-glass.
Garnet, grossularite, see grossularite garnet.
Garnet, group, 4.
Garnet group, characteristic inclusions of, 80-82.
Garnet, pyrope, see pyrope garnet.
Garnet, rhodolite, see rhodolite garnet.
Gas bubbles, 92, 93, 95, 105, 112, 124.
Gauge, estimator, specific gravity test, for, 21.
"Gelatinous" appearance, cultured pearl of, 133.
Gem identification, limitations of tests, 6.
Gem refractometers, 27-31, 143.
Gem testing instruments, essential, 141.
Gem testing instruments, less frequently used, 144-147.
Gemolite, 60, 144.
Gemological Institute of America, 36, 45, 48, 49, 57, 99, 100, 123, 134, 143-146.
Gemological microscope, 61, 62, 144, 145.
Gemstones, classification of, 3, 4.
Gemstones, differences in properties, 5.
Gemstones, nature of, 3-7.
G.I.A. Fluorescent Unit, 99, 100, 145.
Glass, 4, 10, 11, 95, 125-128, 139, 140, 154, 164, 175, 186, 196, 207, 219, 229, 238, 245, 264.
Glass, colors of, 125, 126.
Glass, composition of, 125, 126.
Glass, detection of, 95, 125-128.
Glass, hardness in testing, 10, 11, 128.

Glass, imitation of pearls, tests for, 139, 140.
Glass, inclusions of, 95, 127.
Glass, refractive index of, 128.
Glass, specific gravity, 128.
Graphite, 5.
Gray, white and black nontransparent gemstones and substitutes, identification of, 245-252.
Green and blue nontransparent gemstones and substitutes, identification of, 229-237.
Green transparent gemstones and substitutes, identification of, 175-185.
Grossularite garnet, 82, 175, 186, 196, 229, 264.
Grossularite garnet, hessonite, 82, 186, 196, 264.
Grossularite garnet, hessonite, characteristic inclusions of, 82.
Group, definition of, 3, 4.
Growth lines, detection in immersion cell, 68, 69, 91, 92, 108.
Gubelin, Dr. Edward, Preface.

H

Halo, black, inclusion in corundum, 77.
Hand loupe, 55-57, 63, 144.
Hardness, 14, 146.
Hardness, defined, 9.
Hardness, nontransparent gemstones, blue and green, 237.
Hardness, nontransparent gemstones, red, yellow and brown, 244.
Hardness, nontransparent gemstones, white, gray and black, 251-252.
Hardness pencils or points, 10-14, 146.
Hardness plates, 10-13, 146.
Hardness tables, 14, 237, 244, 251, 252, 259.
Hardness testing, caution, 10, 12.
Hardness test, nontransparent gemstones and substitutes for, 12, 13.
Hardness test, transparent gemstones and substitutes, 10-14.
Hardness tests, 9-14.
Hematite, 9, 74, 245, 264.
Hematite, inclusions in corundum as, 78.
Hematite, fracture of, in identification, 9, 74.
Hemetine, 245, 265.
Hemetine, fracture, 9.
Hessonite, see grossularite garnet, hessonite.
Hiddenite, spodumene, 175, 269.
High-density liquids for specific gravity, 21-23.
Holmes, Ralph J., Preface, 147.
Hyacinth, zircon, see zircon, hyacinth.
Hydrostatic principle, 15, 16-19.

I

Identification, assembled stones, 69, 120-124.
Identification, characteristic imperfections, by means of, 71-96.
Identification, cleavage, by, 8, 74, 75.
Identification, fracture, 9, 74.
Identification, hardness, by, 9-14.
Identification, immersion, by, 69.
Identification, magnification in, 55-70.

Index

- Identification, natural gems by optical and physical properties, 5, 6.
Identification, nontransparent gemstones, blue and green, 229-237.
Identification, nontransparent gemstones, red, yellow and brown, 238-244.
Identification, nontransparent gemstones, white, gray and black, 245-252.
Identification procedure, gemstones and substitutes, 148-152.
Identification procedure, modification for nontransparent gems, 152.
Identification, rough gems, 5, 6.
Identification, specific gravity, value of, 15, 23.
Identification, synthetic gems, 6, 91-96, 102-119.
Identification, transparent gemstones, blue, 164-174.
Identification, transparent gemstones, brown and orange, 196-206.
Identification, transparent gemstones, colorless, 219-223.
Identification, transparent gemstones, green, 175-185.
Identification, transparent gemstones, purple and violet, 154-163.
Identification, transparent gemstones, red and pink, 207-218.
Identification, transparent gemstones, yellow, 186-195.
Identification, unknown stones, limitations of tests, 6, 7.
Idocrase, 229, 265.
I. G. Farbenindustrie, 115.
Illumination, dark-field, 59, 71, 73.
Illumination, microscope, for, 56, 58-62, 64, 67, 73.
Imitation pearls, 139, 140.
Imitations commonly encountered, 121.
Imitations, detection of, 95, 124-128.
Immersion cell, 67-69.
Immersion, identification by, 66, 67.
Immersion liquids listed, 67.
Immersion method, approximate, 37.
Immersion stage, 68.
Immersion, test for assembled stones, 69, 122.
Imperfections, characteristic, in identification, 71-96, 104-119.
Imperfections, defined, 73.
Impurities, 4.
Inclusions, characteristic, determining synthetic gems, use in, 91-96, 104-118.
Inclusions, characteristic, determining unknown gems, use in, 75-96.
Inclusions, characteristic, genuine gemstones of, 75-90.
Inclusions, crystal form of, 5, 6.
Inclusions, dust and, 65.
Inclusions, importance in identification, 55, 71, 72.
"Indestructible" pearls, 139.
Instruments essential to gem testing, 141-147.
Interference figures, 52-54.
Introduction, 1, 2.
Iridescence, 165, 232, 247.
Isotropic, 5, 41.
Isotropic gemstones, table of, 254.
- J**
- Jade, 229, 238, 245, 265., see also Jadeite and nephrite.
Jade, "California," see idocrase, 230, 265.
Jade, "South African," see grossularite garnet, 230, 264.
Jadeite jade, 229, 238, 245, 265.
Jargoon, zircon, see zircon, jargoon.
Jet, 3, 245, 265.
Jeweler's diamond balance for specific gravity, 16-19.
Jolly balance, 20.
- K**
- Kornerupine, 265.
Kunzite, see spodumene, kunzite.
Kyanite, 265.
- L**
- Labradorite feldspar, 4, 164, 229, 245, 265.
Lapis-lazuli, 3, 229, 265.
Lazulite, 229, 265.
Lazurite, lapis-lazuli, 3, 229, 265.
Lead glass, 31, 126.
Lenses, 56.
Leveridge Gauge, 21.
Light, nature of, 41.
Lighting, imperfection resolution, for, 56, 57, 66, 67, 73.
Linde Air Products Company, 103.
Liquid inclusions, 73, 78, 80, 82-88.
Liquids, refractive index determination, used in, 31, 32, 54, 35, 37, 38, 67.
Liquids, specific gravity determination, used in, 21-23.
Loupe, 55-57, 63, 144.
Lucite, plastics, 128, 219, 265, see also plastics.
Luster, adamantine, 149, 156, 166, 177, 198, 209, 221.
Luster difference, 122, 149, 156, 166, 177, 188, 210.
Luster, dull, 9, 74, 156, 166, 177, 210, 232, 240, 247.
Luster, high, 198.
Luster, metallic, 247.
Luster, vitreous, 9, 74, 126, 247, 251.
Luster, waxy, 74, 232, 240, 247.
- M**
- Magnification, 37, 38, 43, 55-70, 123, 133, 149, 150.
Magnification, gem identification, in, 6, 7, 37, 38, 43, 55-70, 123, 133, 149, 150.
Magnification, importance of, 55.
Magnification, pearl tests, in, 133.
Magnification range, 64.
Magnification test for double refraction, 43.
Magnification test for doublet or triplet, 123.
Magnifiers, 56-62, 144.
Magnifying instruments, 56-62, 144.
Malachite, 229, 265.
Marcasite, 266.
Measurement, refractive index, of, 25-27.
Melanite garnet, see andradite garnet melanite.

HANDBOOK OF GEM IDENTIFICATION

- Meleagrina Martensi, 130.
 Metallic luster, 247.
 Methylene iodide, 21, 22, 32, 37, 67.
 Mica inclusions, corundum, in, 77.
 Microcline feldspar, amazonite, 229, 263.
 Microscope, refractive index, for, 37, 38.
 Microscopes, 37, 38, 43, 55-70, 144.
 Microscopes, use of, 37, 38, 63-67.
 Millimeter gauge, 21.
 Millimicrons, 41.
 Mineral, definition, 3.
 Mineralight, 100, 101, 145.
 Mineraloid, definition, 3.
 Minerals, amorphous, 3-5.
 Minerals, crystalline, 4.
 Mohs' Scale, 10, 14.
 Moldavite, 266.
 Molded appearance of back facets, 126, 156, 166, 177, 188, 210, 240, 247.
 Monochromatic light, 28, 30, 35, 36, 51, 146.
 Monochromatic sodium light, readings in, 35, 36, 146.
 Monocular microscope, 57-62.
 Moonstone, chalcedony, 219, 245, 267.
 Moonstone, orthoclase feldspar, 4, 219, 245, 263.
 Moonstone, precious, see orthoclase feldspar, moonstone.
 Morganite, see beryl, morganite.
 Mounting stone, glass slide, on, 64.
 Mounting stone, mechanical holder, in, 64.
- N**
- Nacre, definition, 129.
 Natural, cultured pearls and, identification, 129-139.
 Nature, gemstones of, the, 3-7.
 Nephrite jade, 9, 229, 245, 265.
 Nephrite jade, fracture, 9.
 Newton scales, 21.
 Nicol prism, 62.
 Normal, 25, 26.
- O**
- Obsidian, 245, 266.
 Opal, 3, 164, 186, 196, 207, 219, 229, 238, 245, 266.
 Opal doublet, 121, 231, 245.
 Opal, white, 219, 245, 266.
 Opaque gemstones, hardness tests, 12, 13, 237, 244, 251, 252.
 Opaque gemstones, identification of, 229, 238, 245.
 Optic axis, 42, 50, 52-54.
 Optic character, 50-54, 254.
 Optic character, determination with polariscope, 52-54.
 Optic character, determination with refractometer, 51, 52.
 Optic character table, 254.
 Optic sign, 50-54.
 Orange and brown transparent gemstones and substitutes, identification of, 196-206.
 Orthoclase, 4, 186, 219, 245, 263.
 Orthoclase feldspar, moonstone, 4, 219, 245, 263.
- P**
- Padparadsha, corundum, 196, 262.
 Parfocal, 59.
 Parting, see false cleavage.
 Paste, see glass.
 Payne, C. J., 28, 132.
 Pearl, 3, 129-139, 266.
 Pearl endoscope, 133-136.
 Pearl imitations, 139, 140.
 Pearl, natural, definition, 129.
 Pearl tests, 131-140.
 Pearloscope, 133-136.
 Pearls, cultured and imitations, 130-140, 266.
 Penfield balance, 21.
 Peridot, 14, 24, 39, 42, 70, 175, 186, 266.
 Phenacite, 186, 219, 266.
 Phosphorescence, 99.
 Pink conch pearls, 140.
 Pink coral as conch pearl substitute, 140.
 Pink and red transparent gemstones and substitutes, identification of, 207-218.
 Plane polarized light, 42.
 Plastics, 128, 154, 164, 175, 185, 196, 207, 219, 229, 238, 245, 260.
 Plastics, detection of, 128.
 Plastics, properties of, 128.
 Play of color, 165, 220, 221, 231, 232, 247.
 Pleochroism, 47-50, 159, 169, 170, 180, 181, 191, 201, 213.
 Pleochroism, iolite and quartz, 171.
 Pleochroism, test for with dichroscope, 49, 50.
 Pleochroism, test for with polariscope, 50.
 Pleochroism, tests for, 48-50.
 Plexiglass, plastic, 219, see also plastics.
 Polariscope, 44-54, 143.
 Polarized light, 42.
 Polarizing Instrument Company, 45.
 Polarizing microscope test for refractive index, 37-39.
 Polaroid, 45, 46, 62.
 Prehnite, 266.
 Procedure, identification of gemstones and substitutes, 148-152.
 Procedure identification, modification for nontransparent gemstones, 152.
 Purple and violet transparent gemstones and substitutes, identification of 154-163.
 Purpose of the text, Preface.
 Pyrite, 83, 85, 118, 230, 232, 266.
 Pyrite crystals, natural emerald, in, 85, 118.
 Pyrope garnet, 82, 154, 207, 264.
 Pyrope garnet, characteristic inclusions of, 82.
- Q**
- Quartz, see also chalcedonic quartz, 8, 9, 10, 14, 24, 40, 54, 74, 88, 89, 121, 122, 125, 154, 164, 175, 186, 196, 207, 219, 229, 238, 245, 267-268.
 Quartz, amethyst, 154, 267.
 Quartz, aventurine, 229, 268.
 Quartz, cairngorm, 196, 267.
 Quartz, cat's-eye, 229, 238, 268.
 Quartz, chalcedony, moonstone, 219, 245, 267.
 Quartz, characteristic inclusions of, 88, 89
 Quartz, colorless, 219, 267.
 Quartz, dyed, 164.

Index

- Quartz, fracture, 9, 74.
Quartz, rock crystal, 219, 267.
Quartz, rose, 207, 267.
Quartz, tiger-eye, 238, 267.
Quartz wedge, 54.
- R**
- Radiographic methods, 131, 138, 139.
Rayner Refractometer, 28, 29.
Readings, refractometer, 32-36.
Reconstructed gems, 102.
Red and pink transparent gemstones and substitutes, identification of, 207-218.
Red ring test for doublets, 122, 177, 188, 198.
Red, yellow and brown nontransparent gemstones and substitutes, identification of, 238-244.
Reflection, law of, 25.
Reflection and refraction, 25-27.
Reflection test for double refraction, 44.
Refraction, 25-40.
Refraction, double, 5, 6, 42-47.
Refraction, single, 5, 6, 41-47.
Refractive index, approximate, immersion test, 37.
Refractive index, definition, 27.
Refractive index determination, 25-40.
Refractive index, determination by refractometer, 27-36.
Refractive index table, 39-40, 256-257.
Refractive index, test for doublet or triplet, 122.
Refractive indices, nontransparent blue or green gemstones, 235.
Refractive indices, nontransparent red, yellow and brown gemstones, 242, 243.
Refractive indices, nontransparent white, gray and black gemstones, 250.
Refractive indices, transparent blue gemstones, 170, 171.
Refractive indices, transparent, brown and orange gemstones, 202, 203.
Refractive indices, transparent colorless gemstones, 224, 225.
Refractive indices, transparent green gemstones, 182, 183.
Refractive indices, transparent purple and violet gemstones, 160.
Refractive indices, transparent red and pink gemstones, 214, 215.
Refractive indices, transparent yellow gemstones, 192, 193.
Refractometer, cleaning, 36, 37.
Refractometer, definition, 27.
Refractometer, determination of refractive index by, 32-36.
Refractometer, how to use, 31-37.
Refractometer liquid, 29, 32-35.
Refractometer, makes of, 27-31, 143.
Refractometers, types of, 27-31.
Repeated twinning in corundum, 79.
Rhodolite garnet, 14, 24, 39, 154, 207, 263.
Rhodonite, 238, 239, 268.
Rock crystal, quartz, 219, 267.
Rock, definition, 3.
Rose quartz, see quartz, rose.
Rubellite, tourmaline, see tourmaline, rubellite.
- Ruby, see corundum, ruby.
Rutile crystals, inclusions in corundum, as, 72, 75, 78, 106, 107.
- S**
- Sapphire, see corundum, sapphire.
Sard, see chalcedonic quartz, sard.
Scapolite, 268.
Separation plane in assembled stones, 69, 122, 123, 124, 156, 157, 166, 168, 177, 179, 190, 198, 199, 210, 211, 222.
Serpentine, 14, 24, 40, 229, 268.
Shipley Hand Polariscopes, 44, 45, 143.
Shipley, Robert M., Preface, 120.
Shipley, Robert M., Jr., Preface, 44.
Shipley Universal Motion Immersion Stage, 68.
Siam ruby, see also corundum, ruby, 77, 78.
Siam ruby, characteristic inclusions, 77, 78.
"Silk" inclusions, corundum, in, 72, 78, 106, 107.
"Silk" inclusions, garnet, in, 80, 81.
Sillimanite, 269.
Single band of light in identification, 232, 240.
Single-mirror methods, 134, 135.
Singly refractive, 5, 41, 42.
Six-rayed star, 240, 247.
Smith, The G. F. Herbert Refractometer, 29.
Smithsonite, 269.
Sodium light, monochromatic, readings in, 35, 36.
Species, definition, 3, 4.
Specific gravity, 15-24, 144.
Specific gravity, definition, 15.
Specific gravity, density and, 15.
Specific gravity determination, 15-24, 144.
Specific gravity, exceedingly low, 166, 177, 188, 198, 210, 240.
Specific gravity, nontransparent gemstones, blue and green, 236.
Specific gravity, nontransparent gemstones, red, yellow and brown, 243, 244.
Specific gravity, nontransparent gemstones, white, gray and black, 251.
Specific gravity table, 24, 258.
Specific gravity, test, pearls, for, 131, 132.
Specific gravity, tests for, 15-23.
Specific gravity, transparent gemstones, blue, 172, 173.
Specific gravity, transparent gemstones, brown and orange, 203, 204.
Specific gravity, transparent gemstones, colorless, 225, 226.
Specific gravity, transparent gemstones, green, 183, 184.
Specific gravity, transparent gemstones, purple and violet, 161, 162.
Specific gravity, transparent gemstones, red and pink, 215, 216.
Specific gravity, transparent gemstones, yellow, 193, 194.
Specific gravity, value in identification, 6, 15, 23, 152.
Spectroscope, 146.
Spheue, 14, 24, 39, 42, 175, 186, 196, 269.
Spherical aberration, 56.

HANDBOOK OF GEM IDENTIFICATION

- Spherical bubbles, 92, 93, 95, 105, 122, 124.
- Spherical bubbles, synthetic gemstones, in, 92, 93, 105, 112.
- Spinel, 4, 14, 24, 39, 84, 86, 113-114, 154, 164, 175, 186, 196, 207, 219, 269.
- Spinel, characteristic inclusions of, 5, 84, 86, 113, 114.
- Spinel, colorless, 219.
- Spinel, crystal structure, 4, 5.
- Spinel, octahedra, as corundum inclusions, 75, 77.
- Spinel, orange, 196, 269.
- Spinel, red, 207, 269.
- Spinel, synthetic, see synthetic spinel.
- Splintery fracture, 9, 74.
- Spodumene, 8, 14, 24, 39, 42, 154, 175, 186, 207, 219, 269.
- Spodumene, cleavage of, 8, 74.
- Spodumene, colorless, 219, 269.
- Spodumene, kunzite, 8, 154, 207, 269.
- Spodumene, yellow, 186.
- Star quartz, 76, 89, 90.
- Star quartz foil back, 121, 124, 164, 207, 229, 238.
- Star sapphire, corundum, see corundum, star sapphire.
- Sulphur, refractive index liquid in, 32, 35.
- Swirl marks, glass in, 95, 127.
- Switzer, George, Preface, 147.
- "Synthetic alexandrite," 102.
- "Synthetic amethyst," 102.
- "Synthetic aquamarine," 102.
- Synthetic corundum, 69, 92, 93, 103-111, 154, 164, 175, 186, 196, 207, 219, 262.
- Synthetic corundum, boule, 103-105, 111.
- Synthetic corundum, characteristic inclusions, 92, 93, 105, 106, 108, 109.
- Synthetic corundum, color zones in, 69, 92, 93, 108, 109.
- Synthetic corundum, colors, 103, 104.
- Synthetic corundum, curved striae in, 69, 92, 93, 103, 109.
- Synthetic corundum, detection by immersion, 69.
- Synthetic corundum, dichroism of, 111.
- Synthetic corundum, distinguishing from natural, 102-111.
- Synthetic corundum, fluorescence of, 111.
- Synthetic corundum, growth lines in, 69, 92, 93, 108, 109.
- Synthetic corundum, inclusions of, 92, 93, 104-110.
- Synthetic corundum, indications of origin, 110, 111.
- Synthetic corundum, manufacture, 103, 104.
- Synthetic corundum, properties of, 104, 262.
- Synthetic corundum, striae in, 69, 92, 93, 108, 109.
- Synthetic corundum, Verneuil Process, 103.
- Synthetic emerald, 94, 95, 98, 100, 101, 115-119, 175, 261.
- Synthetic emerald, Chatham process, 117, 118.
- Synthetic emerald, colors of, 117.
- Synthetic emerald, crystal structure of, 117.
- Synthetic emerald, differences from synthetic corundum and spinel, 93, 94.
- Synthetic emerald, Farbenindustrie process, 115.
- Synthetic emerald, fluorescence of, 100, 101, 118, 119.
- Synthetic emerald, fluorescence test, 100, 101, 118, 119.
- Synthetic emerald, how to distinguish from natural, 94, 95, 110, 101, 118, 119.
- Synthetic emerald, inclusions in, 94, 95, 117-119.
- Synthetic emerald, manufacture, 115-117.
- Synthetic emerald, properties of, 115-119.
- "Synthetic garnet," 102.
- Synthetic gemstones, 102-119.
- Synthetic gemstones, definition, 102.
- Synthetic gemstones, inclusions of, 91-95, 102-119.
- Synthetic gemstones, optical and physical properties, 5, 6.
- Synthetic spinel, 69, 93, 99, 111-115, 154, 164, 175, 186, 196, 207, 219, 269.
- Synthetic spinel, anomalous double refraction, 113, 114.
- Synthetic spinel (blue), emerald filter test for, 99.
- Synthetic spinel, chemical composition, 111.
- Synthetic spinel, colors of, 115, 154, 164, 175, 186, 196, 207, 219.
- Synthetic spinel, difference from other synthetic gemstones, 111.
- Synthetic spinel, fluorescence under ultraviolet radiation, 115.
- Synthetic spinel, hardness, 112.
- Synthetic spinel, identification of, 69, 93, 99, 111-115.
- Synthetic spinel, inclusions of, 93, 117, 118.
- Synthetic spinel, indications of, 114, 115.
- Synthetic spinel, properties of, 111, 112.
- Synthetic spinel, toughness, 112.
- "Synthetic topaz," 102.
- "Synthetic zircon," 102.

T

- Talc, 269.
- Tetraiodoethylene, 32.
- Thallium formate, 22.
- Thallium malonate, 22.
- Topaz, 4, 8, 10, 14, 22, 24, 40, 42, 87, 154, 164, 175, 186, 196, 207, 219, 269.
- Topaz, brown and orange, 196-205.
- Topaz, characteristic inclusions of, 87.
- Topaz, cleavage of, 8, 74.
- Topaz, colorless, 219.
- Topaz, dichroism in, 170, 181, 201, 213.
- Topaz, red and pink, 207.
- Tourmaline, 14, 22, 24, 40, 42, 80, 154, 164, 175, 186, 196, 207, 219, 269.
- Tourmaline, Bordeaux, 207, 269.
- Tourmaline, brown and orange, 196-206, 269.
- Tourmaline, colorless, 219, 269.
- Tourmaline, dichroism in, 159, 181, 191, 201, 213.
- Tourmaline, green, characteristic inclusions of, 80.
- Tourmaline, rubellite, 207, 269.

Index

Tourmaline, rubellite, inclusions of, 80.
Transparent gemstones, hardness testing, 10-12.
Trichroism, 48.
Trichroism, alexandrite in, 59, 181, 213.
Trichroism, iolite in, 170.
Triplet, 69, 101, 121-124, 154, 164, 175, 186, 196, 207.
Triplet, detection of, 69, 101, 121-124.
Triplet, immersion test to detect, 69.
Triplet lenses, 56.
Triplet, magnification test for, 123, 124.
Tully Refractometer, 29, 30.
Turquoise, 4, 14, 24, 40, 74, 229, 270.
Turquoise, fracture of, identification in, 74.

U

Ultra-violet lamps 99-102, 145.
Ultra-violet radiation, testing in, 99-102, 118, 119, 122, 123, 145.
Uneven fracture, 9.
Uniaxial, 42, 51-53.

V

Variety, definition of, 3, 4.
Variscite, 14, 24, 40, 229, 270.
Vaseline, 37.
"Vel," 18.
Verneuil oven, 103.
Verneuil process, 103.
Vernier millimeter scale, 38.
Violet and purple transparent gemstones and substitutes, identification of, 154-163.
Vitreous luster, 9, 74, 126, 236, 244, 247, 251.

W

Warmth, feeling of, glass detection in, 126, 156, 166, 177, 188, 198, 210, 232, 240, 247.
Warmth to touch test, 126, 156, 166, 177, 188, 198, 210, 232, 240, 247.

Wave length, 41.
Wave motion, 41.
Westphal Balance, 21.
White, gray and black nontransparent gemstones and substitutes, identification of, 245-252.
White light, refractive index reading in, 35.
White opal, 219, 245, 266.
Willemite, 270.
Wisp-like inclusions, 93, 117, 118.

X

X-radiographic pearl testing method, 138, 139.
X-ray diffraction method, 131, 137, 138.
X-ray equipment, 137, 147.
X-ray methods for pearls, 137-139.

Y

Yellow, red and brown nontransparent gemstones and substitutes, identification of, 238-244.
Yellow transparent gemstones and substitutes, identification of, 186-195.

Z

Zircon, 4, 8, 10, 14, 24, 39, 42, 43, 70, 77, 87, 90, 107, 154, 164, 175, 186, 196, 207, 219, 270.
Zircon, characteristic inclusions of, 77.
Zircon, crystal structure, 4.
Zircon, dichroism in, 169, 201, 213.
Zircon, dispersion, 155, 166, 188, 198, 210, 221.
Zircon, doubling of back facets, 43, 69, 70, 155, 166, 178, 188, 198, 210, 221.
Zircon, fracture of, identification in, 74.
Zircon, hyacinth, 196, 207, 270.
Zircon, inclusions in corundum as, 70, 107.
Zircon, jargon, 219, 270.
Zircon, red, 207.
Zoisite, 270.

TYPOGRAPHY AND
LETTER PRESS PRINTING
BY
LORRIN L. MORRISON,
LOS ANGELES



QE392

.L7

Liddicoat, R. T.
Handbook of gem ident-
ification,

	Jul 7 '52	Nov 3 '52
<i>Wicks</i>	Jul 2 '53	Nov 13 '53
<i>Wicks</i>	Aug 17 '54	AUG 20 '54
<i>Callighan</i>	Sep 5 '56	Feb 5 '57
<i>Carbone</i>	NOV 1 1956	Mar 4 '57
<i>Diodati</i>	Feb 5 '57	Jun 4 '57
<i>Carbone</i>	Jun 4 '57	Jun 6 '57

QE 392

.L7

LIBRARY
MELLON INSTITUTE
PITTSBURGH, PA.

All material must be charged to borrower before it is taken from the Library. Sign surname on book card found in the pocket of each volume, and deposit the card in the slot in the Librarian's desk.

Material shall be returned as soon as possible or upon request of Librarian. All borrowed material is to be returned or renewed quarterly upon notice of Librarian. It shall not be taken from the building except over night or for the week end when necessary.

Each borrower is personally responsible for all items charged against him. All exchanges of books among members are to be made through the Library.





3 8482 00201 1167

Carnegie Mellon Offsite Facility



A104196