

WHO'S WHERE IN TUCSON? *Pull-Out Map Inside!*



Rock & Gem

JANUARY 2010

THE EARTH'S TREASURES • MINERALS AND JEWELRY

Pan in a *FLASH*: Recover More Gold, *Faster*

**BUILD A MINERAL
REFERENCE LIBRARY**



**TRIBUTE TO
A LEGEND:
June Culp Zeitner**

**Britain's Classic
Mineral Species**

R&G Kids:
• Articles • Puzzles • Prizes



www.rockngem.com



**Prospecting from Your Computer:
THE GEOCOMMUNICATOR**

FACETING FOR THE BRIGHTEST AND THE BEST!



Digital Angle Dial



- V2D Digital Upgrade Kits now available
- ULTRA TEC V2R (Analog Version)



Visit Our Website at:
www.ultratec-facet.com



Ultra Tec

1025 E. Chestnut Ave.
Santa Ana, CA 92701



Phone: 714.542.0608
info@ultratec-facet.com



FABRICATORS AND SUPPLIERS
FINDINGS • MOUNTINGS



We stock the most comprehensive collection of precious metal findings and mountings with the most competitive pricing in the industry. Experience the variety and low prices of our superior products and service.

PLATINUM

10K • 14K • 18K

SILVER

GOLD-FILLED



SAME DAY SHIPPING



QUANTITY DISCOUNTS



FINISH & QUALITY



CATALOGS AVAILABLE

MEMBER



54 WEST 47TH STREET, NEW YORK, NY 10036
(212)869-1407 • (800)654-7677 • Fax (212)768-3018
www.rossmetals.com • sales@rossmetals.com

MEMBER IPM



Rock & Gem

Volume 40, Number 1

January 2010

ON THE COVER

This 8-centimeter-high gold specimen is from the Round Mountain Mine in Nye County, Nevada. (Jeff Scovil photo/Alan Day specimen)

FEATURES

A Tribute to a Legend 12
Remembering June Culp Zeitner:
Author, lecturer, mineralogist, friend
by **Brad Cross**

The "Ferrari" Pans 22
New competition gold pans set recovery records
by **Marc Davis**



Classic Minerals of Great Britain 28
Superb specimens were mined in overwhelming quantities
by **Bob Jones**

**A New Prospecting Tool:
The BLM GeoCommunicator** 34
Identify mining claims from your computer
by **Robert Beard**

The 2010 Tucson Shows 42
Where to find your favorite *Rock & Gem* advertisers

Rock & Gem Kids 50
Articles, puzzles and prizes

Build a Mineral Reference Library 56
A good library expands your appreciation of your specimens

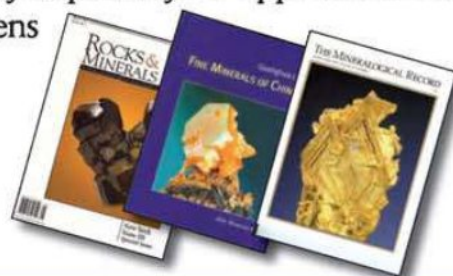

REGULAR COLUMNS

All She Wrote	6	Many Facets	54
Craftsman of the Month	8	Off the Dop	66
Show Dates	10	Contest Rules	68
Shop Talk	18	2009 Article Index	72
Rock Science	44	On the Rocks	78
Picks & Pans	46	Field Notes	80

12

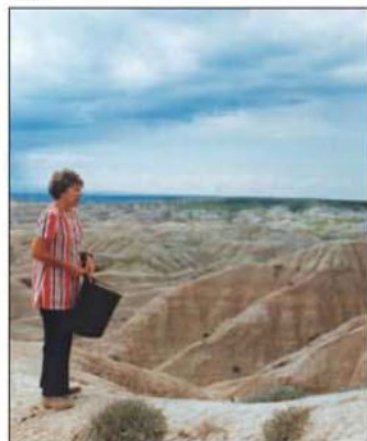

34



SUBSCRIPTION QUESTIONS? Call (760) 291-1549

28



Printed in U.S.A.

Notice: On rare occasions, typographical errors occur in prices listed in magazine advertisements. For this reason, advertisements appearing in *Rock & Gem* should be considered as requests to inquire, rather than as unconditional offers to sell. All prices are subject to change without notice.

Rock & Gem (ISSN 0048-6453, USPS 486-290) is published monthly by JMiller Media (Miller Magazines, Inc.), 290 Maple Ct., Ste. 232, Ventura, California 93003-3517, telephone (805) 644-3824. Periodicals postage paid at Ventura, CA 93006, and additional mailing offices. Single-copy price \$4.99. Subscription in U.S.A. and possessions: 1 year (12 issues) for \$27.95; 2 years for \$49.95; 3 years for \$66.95. Add \$15.00 per year postage for Canada and all other foreign countries. Submission of articles and photos by our readers is welcome, but we can accept no responsibility for loss or damage to unsolicited editorial contributions. Copyright 2010 by JMiller Media (Miller Magazines, Inc.)

POSTMASTER: Send address changes to *Rock & Gem*, P.O. Box 469113, Escondido, CA 92046-9113 or RockAndGem@pcspublink.com



REFINING • SMELTING • ASSAYING

**UP TO 98.5%
QUICK SERVICE
ACCURATE SETTLEMENTS
STONE REMOVAL SERVICE
FREE PICK UP / CONTAINERS**

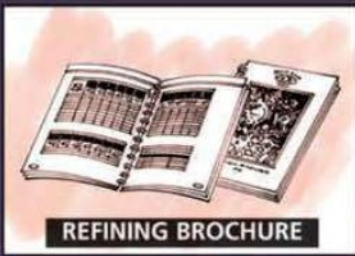
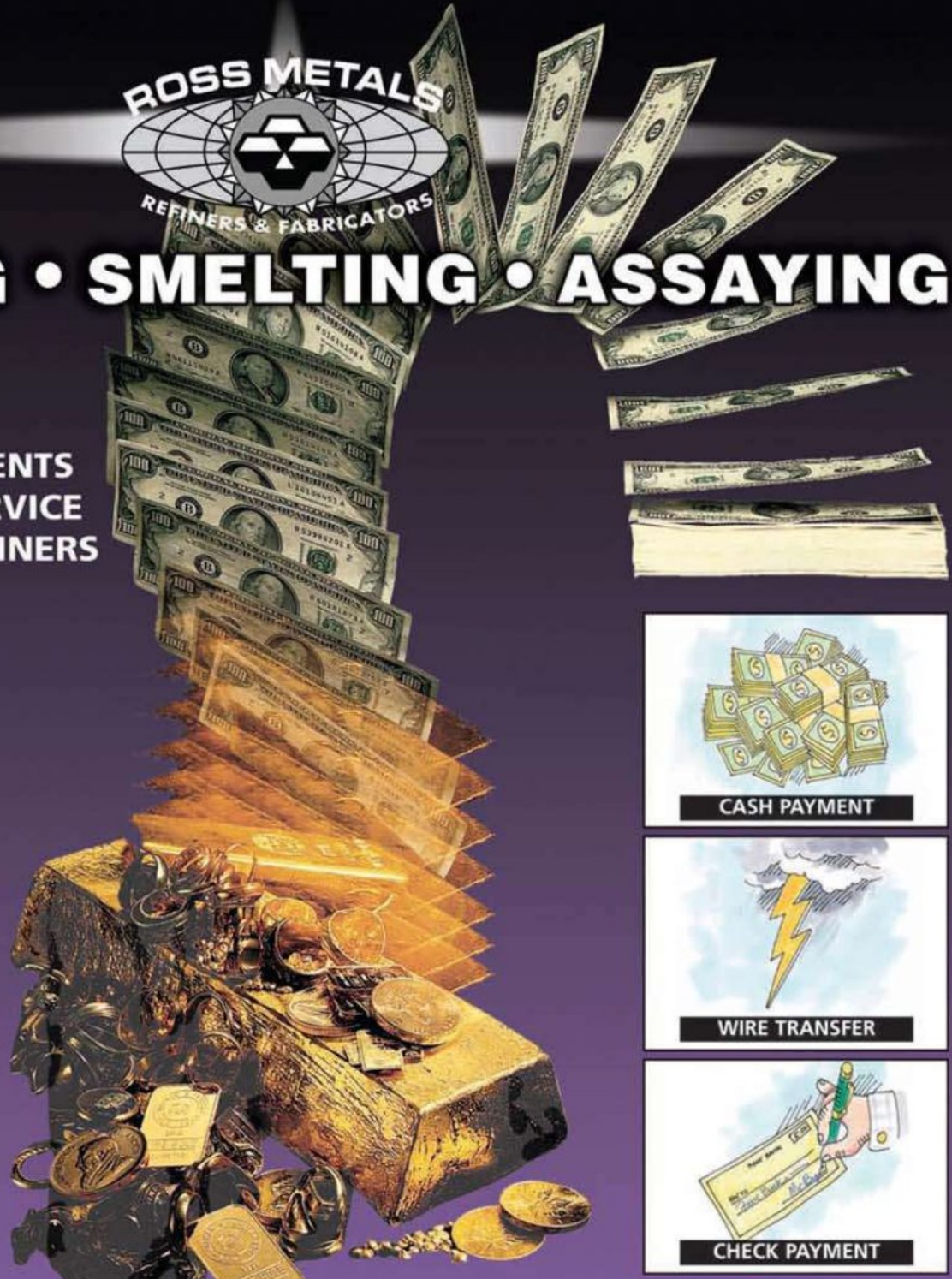

REFINING BROCHURE



CASH PAYMENT



FREE PICK UP SERVICE



WIRE TRANSFER



FREE CONTAINERS



CHECK PAYMENT

ROSS METALS has been a leader in the precious metal industry, serving our customers with the most reliable and efficient refining facilities. We have capacities to process small as well as large lots, solid scrap, polishing sweeps, floor sweeps, bench sweeps, grindings and just about anything gold, silver, and platinum. "Eliminate the middleman" Call us for more details and information.

PRIME REFINERS OF PRECIOUS METALS



BENCH SWEEPS



SCRAP

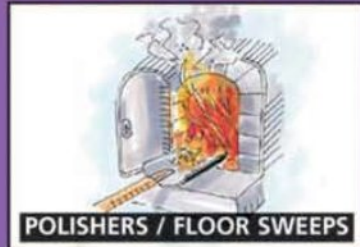

POLISHERS / FLOOR SWEEPS



54 WEST 47TH STREET, NEW YORK, NY 10036
 (212) 869-3993 • (800) 334-7191 • FAX: (212) 869-4807
www.rossmetals.com • refininginfo@rossmetals.com

40 Is Fabulous

People wait to celebrate birthdays until the end of the completed year. Nobody jumps to volunteer, "I'm turning 40 this year!" We're 39 until the last second of the last day has waned away. Even then, we qualify—"I just turned 40"—as if that takes any time off the year we've already lived. We consider ourselves really lucky if the day passes unnoticed by the rest of the world.

Magazines are a bit different. Longevity is a badge of honor that we wear proudly, especially during tough economic times that have witnessed the folding of many a better-funded publication. To wait until the beginning of 2011 to announce that we've been around for four decades would be anticlimactic. We're proud of our years of participation in the hobby and science of minerals, so we're saying it up front: 2010 is *Rock & Gem's* 40th year in print! That gives us the next 12 months to celebrate.

JMiller Media president and owner Jill Miller remembers how her husband, Jim, started the magazine because of one of their daughters:

"Juliet loved to collect rocks (and almost everything else—still does). She was 8 years old and when a rock and gem show came to our local venue, she begged him to take her. He reluctantly did and certainly had his eyes opened! He was astounded at the scope of the show, the beauty it offered, and the amount of people who were obviously so interested. He came back to work, did a ton of research, and *Rock & Gem* was born."

The magazine that was inspired by a child's interest has come a long way in 40 years. It has undergone several redesigns to keep up with the times, including a shift to full color, but the subject matter has not changed; we still celebrate Earth's gems and minerals and the wonderful things that can be made from them.

One of the down sides of age is having to say goodbye to friends and colleagues, such as our founder, Jim Miller (2003) and past columnist John Sinkankas (2002). In this issue, we look back on the remarkable life of a rockhounding giant and former *Rock & Gem* contributor June Culp Zeitner (1916-2009). Her longtime friend and co-author Brad Cross shares his memories and June's own words in "Tribute to a Legend" (page 12).

At the same time, we celebrate the staying power of long-time contributors like our senior consulting editor, Bob Jones, and regular columnists Steve Voynick and William A. Kappel.

You, our faithful readers, are another essential component of our history, whether you've grown up with *Rock & Gem* or discovered it as adults. Your interest keeps us going and your enthusiasm keeps us young. Here's to the next 40 years!



EDITORIAL BOB JONES

Senior Consulting Editor

LYNN VARON
Managing Editor

ROBERT BEARD
JIM BRACE-THOMPSON
WILLIAM A. KAPPELE
JIM PERKINS
DIANE PROKOP
KENNETH H. ROHN
STEVE VOYNICK
Contributing Editors

ART
MARY ROBERTSON
Art Director

JOE HOWARD
Graphic Artist

PRODUCTION
CELESTE WEINGARDT
Production and Marketing
Manager

ADVERTISING
BRIAN ROBERTS
Advertising Director

SOOK GUMPEL
Advertising Manager

EDITORIAL SUBMISSIONS:

Lynn Varon / *Rock & Gem*
290 Maple Ct., Suite 232,
Ventura, CA 93003
(805) 644-3824 ext. 29
e-mail: editor@rockngem.com

ADVERTISING INQUIRIES:

Brian Roberts / *Rock & Gem*
11288 S. Indian Wells Dr.,
Goodyear, AZ 85338
(623) 327-3525 phone
(623) 327-2188 fax
e-mail: BRoberts@jmillermmedia.com

THOMAS TRIMBACH
General Manager

JAMES L. MILLER
Founder



Kingsley North, Inc.

6" Stainless Steel Diamond Grinding/Polishing Unit - Kingsley North

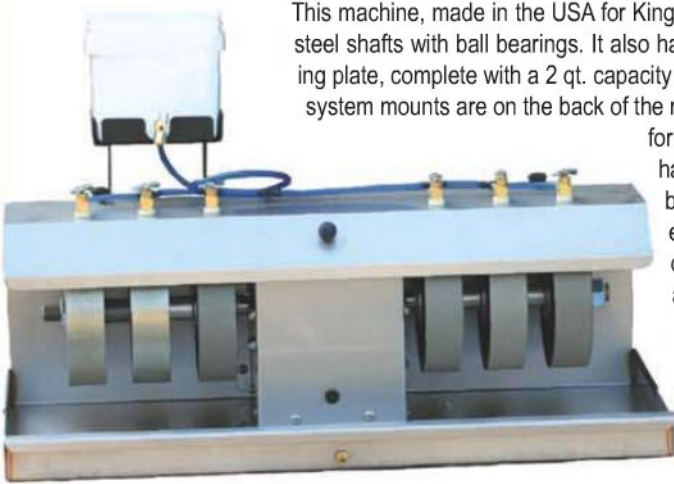

This machine, made in the USA for Kingsley North features an all stainless steel construction 18/8 grade, 3/4" stainless steel shafts with ball bearings. It also has a 1/3 HP, 1725 RPM thermal protected ball bearing motor with rear mounting plate, complete with a 2 qt. capacity adjustable drip water system with 6 shut off valves, one for each wheel. Water system mounts are on the back of the machine. Lid has three hold down screws for easy removal, the shaft is tapped for a 1/4-20 spin-on polish head at both ends, the machine comes with only a right hand spin on head and features a front drain valve. Features two 6" x 1 1/2" metal bonded 80 and 220 grit diamond grinding wheels, plus four 6" x 1 1/2" resin bonded diamond wheels, 325, 600, 1200 & 3000 grits. A right hand 6 x 1/4" 20 spin-on polish head, polishing pad and 2 grams diamond compound is included along with complete instructions, and a 1 year warranty on machine and motor. Dimensions - 26" W x 17" L x 9" H. Ships in two boxes (motor ships separately) wt. 66lbs.

Stock No.	List	SALE**
1-0674	Stainless 6" Dia. Grinding/Polishing Unit \$1550.00	\$1,299.00

**Free shipping on Machines only - Continental 48 states.

6" Diamond Grinding/Polishing Unit - Kingsley North

Machine made in USA for Kingsley North, has an all metal heavy welded -steel construction, ball bearing on a 3/4 diameter shaft. The right hand of the shaft is tapered to accept a 1/4-20 thread spin disc, for easy On/Off polishing (included). Widely spaced wheels allow fast easy progression from grind to brilliant polish. Rear mounted motor plate houses a full 1/3 HP, 1725 RPM commercial duty motor, auto thermal protected, a belt guard for safety. Comes with a wheel wetter watering system (you add water to the bottom of the pan and the water pulsar pumps water to the wheel above). Features two 6" x 1 1/2" metal boned diamond grinding wheels 80 and 220 grit, plus four 6" x 1 1/2" resin bonded diamond wheels 325, 600, 1200 & 3000. A 6" x 1/4-20 right hand spin on disc, a 6" polishing pad with felt, polish compound, optional 18 flexible lamp is available. Overall size: 31 L x 23 W x 14 H. Shipping in two boxes (motor is shipped separately) weight 66 lbs.

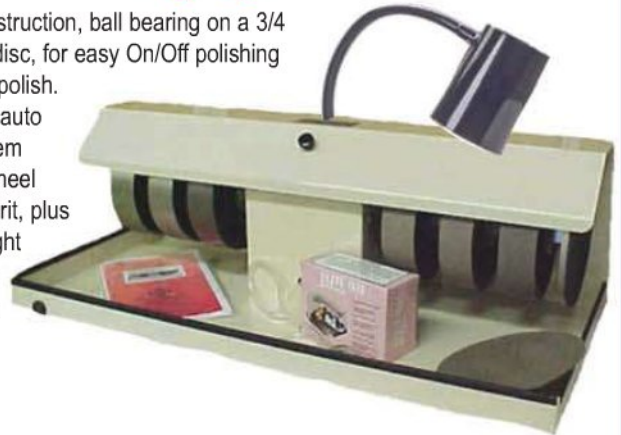

Stock No.	List	SALE**
1-0646	6" Diamond Grinding/Polishing Unit \$1,400.00	\$1,035.00
1-0646L	6" Diamond Grinding/Polishing Unit w/Lamp 1,470.00	1,095.00

**Free shipping on Machines only - Continental 48 states.

FREE 2010 Catalogs

• Secure on-line ordering:

www.kingsleynorth.com

- 164 page Full Color
- All discounted Prices
- Tumblers
- Grinders
- Beading Supplies
- Diamond Wheels
- Diamond Blades
- Plus much more.....

- Saws
- Polishers
- Beads
- Findings



Your Complete Supply House for
Lapidary, Jewelers & Craftsmen

Name _____
Address _____
City _____
State _____ Zip _____



Kingsley North, Inc.

P.O. Box 216: Dept 3
910 Brown Street
Norway, MI 49870-0216

Secure on-line ordering: www.kingsleynorth.com
Toll Free: 1-800-338-9280 • Fax: 1-906-563-7143
email: sales@kingsleynorth.com

CRAFTSMAN OF THE MONTH

January Craftsman of the Month Mike Hewston, of Arlington, Texas, sees this arrowhead pendant as the culmination of three separate projects. "Project one," he says, "began with my second attempt at cuttlefish bone casting. I began by cutting a cuttlefish bone in half and, using the concrete on the driveway, sanded the two soft sides to create a smooth plane against each other. I then carved the arrowhead design into one half of the flattened bone, allowing enough room to carve a sprue to pour the molten silver into. I cast the arrowhead large enough to cut a triangle section out of the center. The arrowhead measured 1 1/4 inches by 2 inches.

"I created a hinged bail made of 26 gauge tapered sheet, with 20 gauge round wire for the edge accent. I then mounted a 3 millimeter serrated bezel and Sleeping Beauty turquoise cabochon to the bail.

"Project two consisted of channel inlay. This was my first attempt at it. As I found out, channel inlay is very labor intensive and meticulous. I drew my triangle design to scale on paper. I then began bending 28 gauge bezel wire for the outside rail of the triangle. This was pinned to a soldering block to hold it in place. I continued cutting pieces of bezel wire to length to complete my inside rail design. These were also pinned to the solder block and soldered together.

"At this point, I retrieved the cuttlefish bone arrowhead, turned it over, and traced the outline of the triangle on the back, exactly where I wanted it mounted. I then soldered the triangle to a 24 gauge sheet of silver for the backplate. The backplate was then trimmed down to approximately 1 millimeter from the outside edge of the bezel. Taking the arrowhead again, I drilled three holes just inside the line of the three corners. Using a jeweler's saw, I cut out the triangle from the arrowhead.

"At this time, the back of the arrowhead needed to be ground down to allow the channel inlay backplate to be recessed into the back of the arrowhead. The channel inlay was to be backset into the recess and held with three silver prongs that I had soldered onto the back. Using lapidary equipment and wet/dry sandpaper, I cut and fit pieces of Mother of Pearl, lapis with some visible pyrite, and Sleeping Beauty turquoise. All but one of these pieces were pressure fit; only one had to be glued. I polished the stones and back mounted the finished triangle. Twisted silver wire was added in a rope effect.

"Project three consisted of making a Viking knit necklace with 26 gauge dead soft silver wire to hold the finished arrowhead pendant. It took about 1 ounce of silver, drawn through a wooden block, to make approximately 30 inches of finished material to create the final uniform-diameter necklace. 



Would you like to be named Craftsman of the Month?

To enter the contest:

- Write a 500-word step-by-step description of how you crafted your lapidary project from start to finish. A copy of the story on diskette, along with your printed manuscript, would be appreciated.
- Take least one sharp, close-up, color photo of the finished project. Submit high-resolution (300 dpi at 4 inches by 5 inches) digital photos .tif or .jpg files on a CD. (Contact the editor with questions.)
- Send your materials, along with your name and street address

(required for delivery), to Craftsman of the Month, *Rock & Gem* magazine, 290 Maple Ct., Ste. 232, Ventura, CA 93003. Submissions will not be returned, so do not send originals. Only winners will be notified.

Craftsman of the Month winners receive a two-speed Dremel Model 200 N/40 MultiPro kit and a wall plaque in recognition of their creativity and craftsmanship. Winning projects are also posted on our Web site, www.rockngem.com.



Shop over 91,000
beading and jewelry making
products online!

FIRE MOUNTAIN
GEMS and Beads®
"Friendly Service" Since 1973

One Fire Mountain Way, DEPT C012 Grants Pass, OR 97526-2373

**America's Favorite
Beading and Jewelry
Supply Company™**

**You supply
the creativity,
we supply
everything
else!®**

Showcasing
the artwork of
Debra L. DeCosta
Rutherfordton, NC
gemsglassglitz.com

Request your **Free** full color
436 page catalog of
HOT jewelry-making supplies
Call 1.800.355.2137

or go online

www.firemountaingems.com

Fire Mountain Gems
and Beads© 2010





"Business To Business"
Gem, Jewelry &
Lapidary Trade Shows

2010

Asheville, NC.....January 5-6

Orlando, FL.....January 8-9-10

Tucson, AZ...January 30-February 12

TUCSON

Gem Mall

January 30 - February 12

Holiday Inn-Palo Verde/Holidome

February 4 - February 12

Grant Inn on Grant Road

January 30 - February 12

West Springfield, MA....March 26-27

Minneapolis, MN.....April 11-12

Detroit, MI.....April 16-17-18

Orlando, FL.....April 30-May 1-2

Franklin, NC.....May 7-8-9

Las Vegas, NV.....June 4-5-6

Detroit, MI.....July 9-10-11

Franklin, NC.....July 22-23-24-25

Spruce Pine, NC...July 29-30-31-August 1

Tucson, AZ...September 9-10-11-12

Minneapolis, MN...September 26-27

Detroit, MI.....October 1-2-3

West Springfield, MA....October 8-9

Asheville, NC.....October 26-27

Orlando, FL.....October 29-30-31

WHOLESALE ONLY
Registration and Proof
of Business Required

Gem & Lapidary Wholesalers, Inc.
859 Petrified Forest Rd.

P.O. Box 98 Flora, MS 39071-0098

Phone: 601.879.8832 • Fax: 601.879.3282

E-mail - info@glwshows.com

Website - glwshows.com

Dates Subject to Change

SHOW DATES

Mark Your Calendar!

Send show information at least four months in advance to *Rock & Gem Show Dates*, 290 Maple Ct., Suite 232, Ventura, CA 93003-3517; fax (805) 644-3875; e-mail: editor@rockngem.com, or use the electronic form at www.rockngem.com/showdates.asp.

JANUARY 2010

1—GLOBE, ARIZONA: 53rd annual show; Gila County Gem & Mineral Society; Gila County Fair Grounds, 3 miles north of Junction US 60-70; Fri. 9-5, Sat. 9-5, Sun. 9-4; adults \$3, students with ID and children with adults free; live demonstrations, door prizes, displays, minerals, jewelry; contact Jim Mills, P.O. Box 487, Miami, AZ 85539, (928) 701-1712; e-mail: oldulking57@hotmail.com

1-10—QUARTZSITE, ARIZONA: Show, "Tyson Wells Rock & Gem Show"; Tyson Wells Enterprises Inc.; Tyson Wells Show Grounds, 100 W. Kuehn St.; 9-5 all days; free admission; contact Kym Scott, P.O. Box 60, Quartzsite, AZ 85346, (928) 927-6364; e-mail: tysonwells@tds.net; Web site: www.tysonwells.com

1-31—LAUGHLIN, NEVADA: Show, "Clouds Jamboree"; Richard Cloud; Avi Resort and Casino - Outdoor RV Park, 10000 Aha Macav Pkwy.; 10-5 every day; contact Richard Cloud, P.O. Box 284, Quartzsite, AZ 85346, (866) 558-7719; e-mail: cloudsjamboree@tds.net; Web site: www.cloudsjamboree.com

8-10—DEL MAR, CALIFORNIA: Show, "Gem Faire"; Gem Faire Inc.; Del Mar Fairgrounds/Exhibit Hall, 2260 Jimmy Durante Blvd.; Fri. 12-7, Sat. 10-6, Sun. 10-5; \$5 weekend pass; contact Yooy Nelson, (503) 252-8300; e-mail: info@gemfaire.com; Web site: www.gemfaire.com

8-10—MESA, ARIZONA: 38th annual show, "A.L. Flagg Gem & Mineral Show"; Mesa Community College, US Hwy. 60 and Dobson Rd.; free admission; Peralta Stones display, more than 100 dealers, local clubs and organizations, displays, free activities for children, kids' egg carton kits; contact Ray Grant, (480) 814-9086; e-mail: raycyn@cox.net; Web sites: www.azminfun.com and www.flaggshow.info

15-17—LARGO (ST. PETERSBURG), FLORIDA: 34th annual show and sale; Pinellas Geological Society; Largo Cultural Center, Parkside Room, 105 Central Park Dr.; Fri. 10-6, Sat. 10-6, Sun. 12-5; contact Hugh Sheffield, (727) 894-2440

15-17—SANTA ROSA, CALIFORNIA: Show, "Gem Faire"; Gem Faire Inc.; Sonoma County Fairgrounds/Grace Pavilion, 1350 Bennett Valley Rd.; Fri. 12-7, Sat. 10-6, Sun. 10-5; \$5 weekend pass; contact Yooy Nelson, (503) 252-8300; e-mail: info@gemfaire.com; Web site: www.gemfaire.com

15-17—SARASOTA, FLORIDA: Show; Frank Cox Productions; Municipal Auditorium, 801 N. Tamiami Trail (Hwy. 41); Fri. 10-5, Sat. 10-5, Sun. 10-5; gems, jewelry, beads; contact Frank Cox Productions, 755 S. Palm Ave. #203, Sarasota, FL 34236, (841) 954-0202; e-mail: frankcox@comcast.net; Web site: www.frankcoxproductions.com

16-17—DeLAND, FLORIDA: 39th annual show; Tomoka Gem & Mineral Society; Volusia County Fair Grounds, State Rte. 44; Sat. 10-6, Sun. 10-5; adults \$4, children 12 and under free; hourly door prizes, grand prize, silent auction, kids' activity table, TFG Faceters Guild demonstrations and Q&A, other demonstrations; contact Florence D. Nordquist, 521 S. Palmetto Ave., Daytona Beach, FL 32114, (386) 226-4032; e-mail: fndesign@aol.com; Web site: www.tomokagms.org

16-17—EXETER, CALIFORNIA: Show, "Gemboree"; Tule Gem & Mineral Club; Veteran's Memorial Bldg., Hwy. 65; Sat. 10-5, Sun. 10-4; free admission; dealers, gems, grab bags, club displays, jewelry, rocks, minerals, lapidary supplies, demonstrations, "Wheel of Fortune" door prizes; contact Pepper Okada, 5924 W. Iris Ct., Visalia, CA 93277, (559) 733-5842; e-mail: pepperok@clearwire.net

16-17—FREDERICKSBURG, TEXAS: Show, "Hill Country Gem & Mineral Show"; Fredericksburg Rockhounds; Pioneer Pavilion, Lady Bird Johnson Municipal Park, 1606 S. Hwy.

16, south of downtown Fredericksburg; Sat. 9-6, Sun. 10-5; free admission; Rollin' Rock meeting Sun., hourly door prizes; contact Jeff Smith, 208 Castle Pines Dr., Kerrville, TX 78028, (830) 895-9630; e-mail: jeffbrenda@windstream.net; Web site: www.fredericksburgrockhounds.org

22-24—HILLSBORO, OREGON: Show, "Gem Faire"; Gem Faire Inc.; Washington County Fairgrounds, 873 NE 34th Ave.; Fri. 12-7, Sat. 10-6, Sun. 10-5; \$5 weekend pass; contact Yooy Nelson, (503) 252-8300; e-mail: info@gemfaire.com; Web site: www.gemfaire.com

22-24—ST. PETERSBURG, FLORIDA: Show; Frank Cox Productions; The Coliseum, 535 4th Ave. N; Fri. 10-5, Sat. 10-5, Sun. 10-5; gems, jewelry, beads; contact Frank Cox Productions, 755 S. Palm Ave. #203, Sarasota, FL 34236, (841) 954-0202; e-mail: frankcox@comcast.net; Web site: www.frankcoxproductions.com

22-24—TYLER, TEXAS: Show, "Gemstone and Jewelry Showcase"; East Texas Gem & Mineral Society; Rose Garden Center, 420 Rose Park Dr.; Fri. 9-5, Sat. 10-6, Sun. 10-5; adults \$3, students \$1; exhibits, demonstrations, fluorescent mineral display, geode cracking, dealers, rocks, minerals, jewelry, fossils, supplies, Wheel of Fortune, silent auction; contact Keith Harmon, 8316 Oxford Dr., Tyler, TX 75703, (903) 581-4068; e-mail: khamon1219@sbcglobal.net

29-31—SAN RAFAEL, CALIFORNIA: Show, "Gem Faire"; Gem Faire Inc.; Marin Center/Exhibit Hall, 10 Avenue of the Flags; Fri. 12-7, Sat. 10-6, Sun. 10-5; \$5 weekend pass; contact Yooy Nelson, (503) 252-8300; e-mail: info@gemfaire.com; Web site: www.gemfaire.com

30-31—PANAMA CITY, FLORIDA: 19th annual show; Panama City Gem & Mineral Society; Bay County Fairgrounds, American Legion Bldg., U.S. Hwy. 98 (15th St.) and Sherman Ave.; Sat. 9-5, Sun. 9-4; free admission; door prizes, gems, minerals, fossils, beads, jewelry, lapidary arts, wire wrapping, exhibits; contact Ruth Allredge, 316 Cherry St. #38, Panama City, FL 32401, (850) 784-0740; e-mail: Aquezpie@comcast.net

JANUARY-FEBRUARY 2010

1-28—QUARTZSITE, ARIZONA: Desert Gardens International Rock, Gem & Mineral Show; Desert Gardens RV Park; 1055 Kuhlen St., south side of I-10, along frontage road; 8-5 daily; free admission; wholesale/retail, crystals, minerals, rough, polished, jewelry; contact Sharon or Sandy, Desert Gardens RV Park, P.O. Box 2818, Quartzsite, AZ 85346, (928) 927-6361; e-mail: info@desertgardensrvpark.net; Web site: www.desertgardensrvpark.net

30-12—TUCSON, ARIZONA: Business to Business Gem Trade Show; Gem and Lapidary Wholesalers Inc.; The Gem Mall, 4475 S. Country Club Rd.; daily 10-6, last day 10-3; contact Gem and Lapidary Wholesalers Inc., P.O. Box 98, Flora, MS 39071-0098, (601) 879-8832; e-mail: info@glwshows.com; Web site: glwshows.com

30-12—TUCSON, ARIZONA: Business to Business Gem Trade Show; Gem and Lapidary Wholesalers Inc.; The Grant Inn, 1365 W. Grant Rd. (I-10 and Grant Rd.); daily 10-6, last day 10-3; contact Gem and Lapidary Wholesalers Inc., P.O. Box 98, Flora, MS 39071-0098, (601) 879-8832; e-mail: info@glwshows.com; Web site: glwshows.com

30-13—TUCSON, ARIZONA: Show, "Arizona Mineral & Fossil Show"; Martin Zinn Expositions; InnSuites Hotel, 475 N. Granada Ave.; Sat. 10-6; free admission; AMFS Treasure Hunt: win prizes for visiting show locations, pre-register online or at the InnSuites Hotel; daily drawings Feb. 1-10, more than 400 vendors in four locations; contact Regina Aumente, P.O. Box 665, Bernalillo, NM 87004, (505) 867-0425; e-mail: mzexpos@aol.com; Web site: www.mzexpos.com

continued on page 20

2010 TUCSON ARIZONA MINERAL & FOSSIL Show™

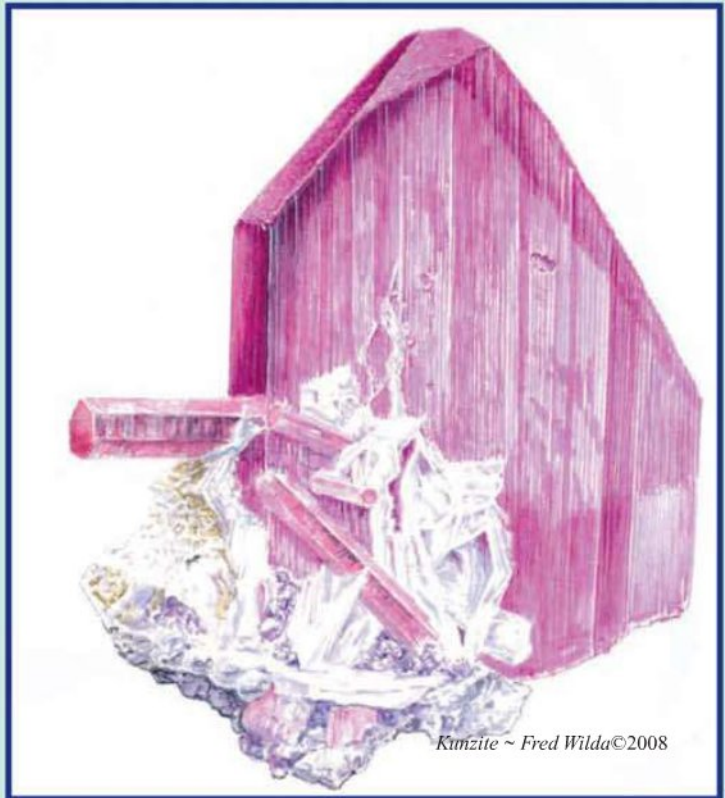

JAN. 30 - FEB. 13 *daily 10-6*

Register for the AMFS Treasure Hunt at www.mzexpos.com!!

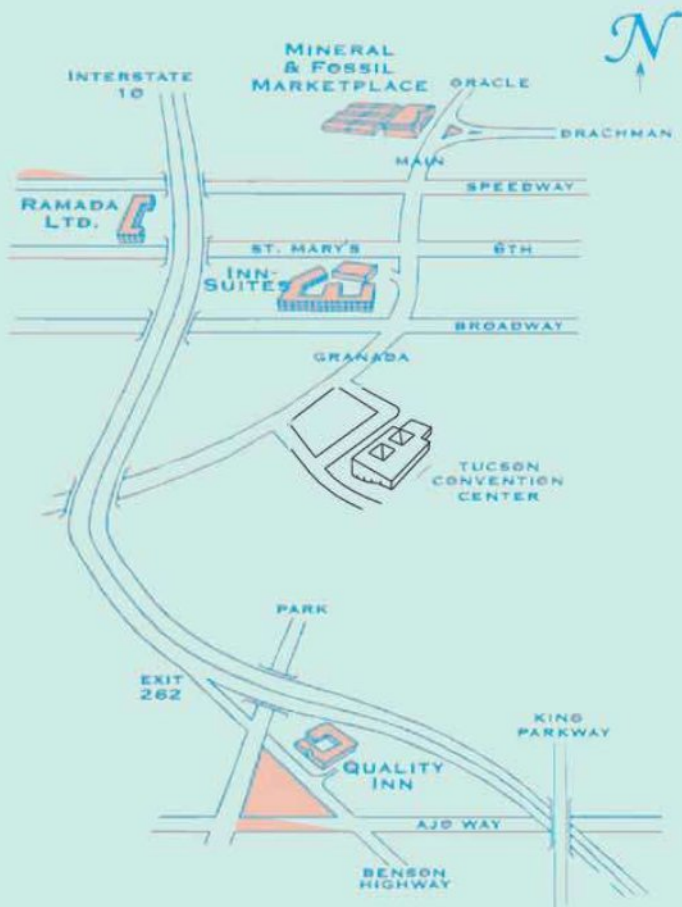

***Four Locations
with the dealers to see first!***

- ◆ **Quality Inn - Benson Hwy.**
I-10, Exit 262, NE corner of Benson Hwy at Park
- ◆ **InnSuites Hotel - Downtown**
475 N. Granada Ave., at St. Marys
- ◆ **Ramada Ltd. - Downtown**
665 N. Freeway, at St. Marys
- ◆ **Mineral & Fossil Marketplace**
1333 N. Oracle, at Drachman

450 TOP Quality Dealers

Retail ◆ Wholesale
Open to the public ◆ Free Admission & Parking

Martin Zinn Expositions, L.L.C.
P.O. Box 665, Bernalillo, NM 87004
fax: (303) 223-3478
mzexpos@aol.com, www.mzexpos.com

A TRIBUTE TO A LEGEND



Remembering June Culp Zeitner:
Author, Lecturer, Mineralogist, Friend



ZEITNER FAMILY PHOTO

June Culp Zeitner accepted the Carnegie Award in 2006 at the Tucson Gem & Mineral Show.

Story by Brad Cross

As a teenager in the late 1960s, I could be found anxiously waiting by the mailbox the second week of every month for the arrival of a large manila envelope. The long-awaited delivery of the *Lapidary Journal* was a huge thrill for me. Before I even made it back inside the house, I had already scanned the Table of Contents for the name June Culp Zeitner. The lady unknowingly had me hooked at an early age and, through her

creative writing, was taking me on monthly field trips, teaching me new lapidary techniques, or sharing the promise of an upcoming gem and mineral show. Those who have been involved in the hobby for any length of time know the name quite well and recognize her as a voice of authority, a heartbeat of the hobby, who had a heavy hand in promoting gems and minerals to their modern day popularity.

June authored nine books and more than 1,000 magazine articles. For over 30 years, she was Special Assistant Editor of *Lapidary Journal* and authored columns and articles for *Rock & Gem*, *Gems and Minerals*, and *Rocks and Minerals* magazines. With her husband, Albert Zeitner, June traveled and explored the 48 contiguous United States, much of Canada, and Mexico. They shared their travels and discoveries with the rock-hound community. That whirlwind of energy ended on Oct. 11, 2009 when the classic author, lecturer, mineralogist and friend died at the age of 93 in her Rapid City, South Dakota, home. Up until her last few days, June would sit in her chair with a twinkle in her eye, surrounded by a pile of mineral books and her most favorite specimens.

Born on Feb. 7, 1916 in Bay City, Michigan, June was the eldest of five sisters who all shared an enthusiasm for rocks, minerals and fossils, as well as the beautiful handcrafted items that could be fashioned from many of them. Her family moved from Michigan to Springfield, South Dakota, and then settled in Aberdeen, South Dakota, where June graduated *cum laude* from Northern State University. Her major disciplines were English and art, with minors in speech and science. June also completed post graduate work in art, which she later employed in her sketches of agates, minerals and fossils to accompany her articles at a time when photography was not readily available.

I first "officially" met June in the early 1970s when she wrote an article on me and the national trophy for lapidary that I had won at the American Federation of Mineralogical Societies (AFMS) show in Lincoln, Nebraska. It was the beginning of a personal friendship that has been one of the most rewarding parts of the hobby for me. In recent years, June and I spent a number of Sunday afternoons conducting audio recordings of the history of her life and the hobby. As I sat down to author this article, I thought I would share her words with the hope that the reader would enjoy an overview of how the hobby has changed and developed over the years and what great contributions this magnificent lady made to its modern-day success.

IN HER OWN WORDS

"About 70 years ago," June said, "I moved from Aberdeen to Mission to accept a teaching position and met the man who was to become my husband. I thought he was pretty good looking, kind, generous, and his family owned their own hardware store, lumberyard, and tourist cabins. Albert's German-Russian family had converted one of the cabins into a natural history museum and rock shop where Albert oversaw their collection of petrified wood, fossils, Indian artifacts, and other rocks. His father spoke



ZEITNER FAMILY PHOTO

June collected copper minerals in Michigan in 1998, just as she did on her honeymoon in 1941.

and wrote little English and the museum specimens lacked labels, so I enthusiastically volunteered to label the collection. It was really an attempt to attract Albert's attention. If the way to a man's heart is through his specimens, I was successful.

"Albert's and my first date was a drive into South Dakota's White River Badlands. I thought when he parked in the middle of nowhere that it was a new approach for a date. But then he got out of the car and walked away. I was really uneasy and stayed close to the car, watching him pick up rocks and mutter to himself. He would lick them, rub them, hold them up to the light, and then disappear out of site. After a few minutes, I could hear his frantic voice echo, 'Fairburn! Fairburn!' I thought to myself that there must be something burning and he had hurt himself. Of course, I realize now that he was referring to the treasured Fairburn agate. The lesson that Albert taught me about polishing the agate we found on our first date was my introduction into the hobby that took over my life.



ZEITNER FAMILY PHOTO

In 1976, June was crowned the "First Lady of Gems" at a ceremony on the White House lawn.



ZEITNER FAMILY PHOTO

June's first date with her future husband was spent collecting Fairburn agate in the badlands of South Dakota.

GEODES

The Leading Supplier of Keokuk, Iowa
Geodes



- Guaranteed Hollow Whole Geodes
- Opened Quartz & Calcite Geode Pairs, Halves & Pieces
- Sizes up to 12 Inches Regularly Available!
- Break Your Own Geodes for School & Scout Projects
- Retail & Wholesale
- eBay Seller ID: geode4



Contact us for your free
Wholesale Geode Price List!
Easy, secure, and accurate
ordering online available!

The
Geode Gallery

Revealing Nature's Surprises

1131 80th St. Roseville, IL 61473

(309) 335-6740

sand@maplecity.com

Imagine...

Profits



BEZEL FORM™

434-941-6275

www.wirewrapmandrels.com

Ackley's Rocks

Dept B
3230 N. Stone Ave.
Colorado Springs, CO 80907
(719) 633-1153

PROMPT MAIL ORDER SERVICE

18" chains \$5.50/doz.

24" chains \$6.50/doz.

Gold or silver color. Plus postage.

Send \$1.00 (refunded on first order) for our catalog of lapidary supplies, silversmith supplies, jewelry boxes & trays, mountings and findings.

A TRIBUTE TO A LEGEND from page 13

"Albert and I married in 1941 and we spent our honeymoon picking up agates in Minnesota and collecting copper minerals in Michigan. It was about this time that my father-in-law came back from vacation to the western states with big news for us. He said that other people collected rocks besides us and announced that there was even a magazine about rocks known as *The Mineralogist* and he had subscribed to it. Even rock clubs were being formed! Although by this time I was a confirmed collector, I had a dim view of the future of the hobby. I thought there were only a limited number of good rocks which would quickly be picked up, instantly putting a stop to the whole thing.

"Through articles in *The Mineralogist*, Albert and his dad become convinced they could build equipment to cut and polish their rocks. And they did. I well remember the first rocks we bought. We decided that dad should have some Australian opal for Christmas, so we stretched our budget and sent \$20 for a full pound. He kept the finest pieces for the museum display and then cut the remainder into cabochons that he gave away with abandon. We never were quite sure we got our money's worth.

"By 1945, we had decided that our jobs got in the way of rockhounding and we put the hardware store up for sale. It finally sold in 1949 and so I quit my job as Superintendent of Todd County High School and we made our craziest acquisition ever. We bought a trailer house by mail. We ordered a 31-foot trailer in days when there were hardly any on the road and none were over 22 foot. Our families were thoroughly convinced that we had lost our minds and that we would be back home in a few short weeks with our tails shamefully tucked between our legs. We started the 12-month long rock hunting trip from the factory by driving the wrong way down a one-way street in Chicago. We had four flat tires the first day alone, but we were determined. Our objective was to visit all the major rock and mineral localities in the 48 states and ultimately buy another hardware business similar to the one we sold before our trip.

"Gas was 20 cents a gallon and bread was 10 cents a loaf. Our budget was \$125 per month. There were no field guides at the time, so we read *The Mineralogist*, soaking up everything we could about collectors and new localities. It was a great, wide world and it needed excavating.

"We were self-taught. We had no idea how gem pockets occurred until we dug in the pockets ourselves. We broke a few tourmaline, amazonite, and smoky quartz



ZEITNER FAMILY PHOTO

June's "how-to" articles on jewelry making and lapidary techniques were among the first of their kind.

crystals in our first attempts, but when we saw how they grew, we understood more about them. We collected at least four days a week and spent the rest of the time washing, sorting, admiring, and shipping our rocks back home. Obviously, the trip lasted longer than a year and we didn't mean for it to go on and on. We had been windblown, sunburned, insect bitten, and exhausted. We had flat tires, vapor-locked engines, and transmission failures, but we had some of the prettiest rocks you could ever imagine, we had met some of the finest people ever, and we were happy. That 12-month planned trip turned out to be a journey that lasted 30 years. We weren't wealthy, and to sacrifice an income in order to follow our dreams was to invite scorn and ridicule.

"After this wonderful trip, I finally decided that maybe I had something to write about. My first writing assignment was in 1952 for *The Mineralogist*. The editor, Dr. Dake, couldn't pay me cash, so instead he sent me an encouraging letter, a box of rocks, and some issues of the magazine. The response I got from the first article was unbelievable. I had found my niche.

"Each new trip was based on the pretense of hunting for a new hardware store to purchase. We would travel on a new adventure to Texas, North Carolina, or Arizona. Albert did intend to buy a new store. He must have looked at a hundred or more, but he just never found one that suited him. So we would look in another place with nice rocks. Some years we traveled constantly and others we split between our home in Mission and out on another great adventure."

SHARING THE WEALTH

About five years ago, June shared the fruits of her life-long collecting trip with me on a visit to her home. Imagine a base-



ment, as well as a two-car garage, loaded with hundreds of old, wooden U.S. military ammo crates. Each crate was loaded with minerals, rocks and fossils that were carefully wrapped in vintage newspaper from the 1950s, '60s and '70s. June stood by watching with a twinkle in her eyes as the rusty old nails were removed from each box. Each unmarked crate revealed something different: one contained Mexican agate, another contained petrified wood, and a third contained ammonites. Each crate contained two treasures: the mineralogical wonder itself and an accompanying story of where and how it was found.

June began authoring the first of her many books in 1956 with the debut of *Midwest Gem Trails*, the first in a series of guidebooks for the rockhound. Her field guides were always warmly readable and mixed locality descriptions, tourist information, and history lessons along with mineral pictures and landscape photos. Her "how-to" articles on jewelry making and lapidary techniques were among the first of their kind. June wrote the first articles on jewelry making when "bead stringing" wasn't even a big part of our hobby. She monitored Bureau of Land Management laws and regulations and their effects on the hobby. Many times, she was the first to introduce new gem materials from around the world to her readers.

June was a regular lecturer at gem and mineral shows throughout the country, and her attendance was often a big draw. It was at these shows that she met many of the "hidden talents" of the hobby. She encouraged them to write their own articles and share their lapidary techniques with the world. For those who didn't want to write their own story, June took matters into her own hands and described their techniques and state-of-the-art designs. A number of today's most talented lapidary artisans, jewelers and collectors received the big boost they needed for life-long

success from June's verbal encouragement and written articles.

In the early 1960s, Albert and June were co-sponsors of Operation Rockhound, in which hundreds of collectors were led by motor tour into Mexico to hunt agate, opal, obsidian and topaz at a time when Mexico was a "foreign and exotic land". Many of those who joined the Zeitners on this odyssey weren't interested in rocks at the start, but returned to the United States as official rockhounds.

This special lady founded more than a dozen gem and mineral clubs, along with the National Rockhound and Lapidary Hall of Fame. She founded the state stone program, through which each state has adopted an official state gem, mineral, fossil or rock. The idea developed at an AFMS show in Des Moines, Iowa, in the 1960s. "We had such wonderful gems and minerals in the U.S. Every state had something to be proud of and I was tired of getting information from the various states bragging about their state flower, state bird, or state animal. I knew it was time for us to show our pride by having a state stone and gem," she said.

Over the years, June was presented with honors and awards; the list would fill a legal pad. She was crowned at the White House by the International Gem and Jewelry Show as the "First Lady of Gems" in 1976. In 2006, she was presented with the Carnegie Museum of Natural History's Mineralogical Award, and in 2007, she was given a Lifetime Achievement Award at an international agate symposium held at the University of Wisconsin. She also received several prestigious awards for her writing. None of the recognitions, however, were as rewarding to June as seeing the success in the many friends she helped start in the hobby.

Albert and June amassed a significant collection of rocks, gems and fossils, portions of which are currently on display at the Pioneer Auto Show in Murdo, South Dakota; the Black Hills Institute and the Black Hills Museum of Natural History in Hill City, South Dakota; and the Museum of Geology at the South Dakota School of Mines and Technology in Rapid City.

Whether you knew her personally or not, with June's passing we've all lost a friend and mentor. She was special not only to me, but to each one of us. She devoted her life to our hobby and lit a fire within the gem and mineral world that has never gone out, and it never will, thanks to her. It glows in places and parts without number. It glows in mind and it beats with a rhythm of many memories. Thank you, June, for showing us the beauty around us! 💎

CFC JEWELRY SUPPLIES
"The Custom Alternative"

Custom Fashion Cabs is offering an alternative. A new template to cut some cool shapes and the settings to mount them when you are done!

KEEP AN EYE ON US AS THIS IS ONLY THE START
MORE TO COME

(517) 223-3164
cfcjewelrysupplies.com

**Kingsley North
Rock Pry Bar** 

Sale \$20.25

Stock No. 7-0311

18" length, forged "I" beam construction, for easy prying, raking out crevices. Imported. 16 oz. weight. -Dealers welcome-

Kingsley North, Inc.
P.O. Box 216
Norway, Michigan 49870
Phone (800)338-9280
www.kingsleynorth.com

Mississippi Gem & Mineral Society

Announces its 51st Annual
Gem, Mineral, Fossil and Jewelry Show

**State Fairgrounds
Jackson, Mississippi
Trade Mart Building**

Saturday, February 27, 9am - 6pm
Sunday, February 28, 10am - 5pm
Adults \$5.00 • Students \$3.00

24 Dealers of Gems, Minerals, Fossils, Jewelry, Beads, Lapidary Tools and More

MGMS Demonstrations of all Lapidary Art including Cabochon Cutting, Flint Knapping, Wire Wrapping, and much more

Junior Demonstration Table, Colleges and Groups, Exhibits, Touch-and-See with Braille Labels

<http://missgems.org>

Bring a Friend and Spend the Day

The Smart Choice!

**F
I
N
I
S
H
I
N
G**



*Raytech has a machine to suit your application, whether you make castings, stampings, fabrications, or process gemstones. **Raytech is the world's leader** in the manufacturing of small mass finishing equipment and accessories.*

Contact your local distributor
or phone 1-800-243-7163
for a full line catalog
www.raytech-ind.com

RAYTECH INDUSTRIES
A Division of Lyman Products
475 Smith Street
Middletown, CT 06457

Ph: 860-632-2020
Fax: 860-632-1699

Visit our Website

www.raytech-ind.com



U L T R A V I O L E T L A M P S

*The smart
choice
in making
the invisible
visible is
Raytech!*

The Smart Choice!



*R*aytech offers
over 30 models
of short, long
and midwave
Ultraviolet Lamps.
From portable to
display, we have
a model that suits
your requirements.

*For over 45 years, Raytech has been
the leader in Ultraviolet Lamps.*

Contact your local distributor
or phone 1-800-243-7163
for a full line catalog
www.raytech-ind.com

RAYTECH INDUSTRIES
A Division of Lyman Products
475 Smith Street
Middletown, CT 06457

Ph: 860-632-2020
Fax: 860-632-1699



**Photo Courtesy of Fluorescent Mineral Society, Inc.*

ABRASIVE GRIT & POLISH

100% VIRGIN
SILICON CARBIDE
STRAIGHT GRADED
30 - 1200 GRIT

TIN & CERIUM OXIDE
PLASTIC PELLETS
CORN COB
WALNUT SHELLS
MOUNTED STONES

EXCELLENT PRICES
OUTSTANDING SERVICE

CALL FOR PRICE LIST

jesco products, inc.

1-800-422-GRIT

ORDER 24 HRS A DAY @

www.jescoproducts.com

email: jesco@jescoproducts.com

IN BUSINESS SINCE 1986

Easy Steps Video Step-by-Step Method Jewelry Design Jewelry Crafting Gem Cutting.

Includes: Lapidary, Faceting, Carving, Wire Work, Bead Stringing & Knotting, Soldering, Repair, Wax Casting, and more. One of the most extensive VHS tape and DVD libraries by master designers and master craftsman.

For a free Catalog
call 800.382.3237

www.EasyStepsVideo.com

TIRED OF
DIAMOND
DRILL
BITS
THAT
DO
NOT
LAST?



www.badgersinteredtools.com

SHOP TALK

by William A. Kappeler

A New Machine

If you are new to the lapidary hobby, you may have decided that you are in need of a machine. If you already have a saw, perhaps you now would like a cabber, a flat lap, or even a faceting machine. Or if you are like some of us and are using machines that are about the same age as the rocks they are cutting and grinding, you might just like something new.

The folks in all three of these categories have the same choices facing them. The first, of course, is simply to buy a new lapidary machine. I always recommend that, if your sole objective is to make cabochons and money is not a big problem, you go ahead and buy a brand-new machine from one of the many fine manufacturers out there. Their machines are designed and built well, and will serve you for a long, long time. If, however, you are on a tight budget or if you just think that part of the fun of using tools and machines is making or rebuilding them yourself, then you may be able to get both that new cabber and Susie's braces.

SAWS

The simplest type of lapidary saw to build would probably be a small trim saw. An easy way to do this is to buy the parts and assemble them at home. Inland Lapidary sells separate parts for their saws, so you can buy what you need to and make the rest.

If you want to start from scratch, which is how I like to do it, you should get catalogs from the major manufacturers and scour them to see just how the machine you want to build is made and what parts you might need. Also, look at machines anywhere you can find them: at stores, at rock and gem shows, online, or at a local club's shop.

Slab saws and so-called slab/trim saws are a little more complicated to make, since they require a vise in which to hold the rock and a means for the vise to slide, as well as some kind of power feed. They are well within the experienced do-it-yourselfer's abilities, though. For saws with blades that are over 10 inches in diameter, the price starts to skyrocket. This is primarily because of the larger components required. The price of a 36-inch blade is probably enough to keep all the kids in the neighborhood in braces.



CABBERS

The easiest type of cabber to build is the type that uses diamond disks rather than wheels. A disk-type machine can be made by simply adding a work arbor to a motor shaft and rigging up some splash guards and a catch pan. The wheel-type machine is a little more difficult and a little more expensive to make, since it must have a multiple-wheel arbor. Either one of these machines, however, should be well within the ability of a journeyman do-it-yourselfer.

FLAT LAPS

A rotating flat lap is essentially just a disk-type cabber that has been turned 90 degrees. The critical part of building one is making sure that the splash pan has been sealed properly so that no water gets into the motor.

You can find the following parts for your home-built machines on the following Web sites:

Trim saw parts

Inland Lapidary (www.inlandlapidary.com)

Arbors for saws, cabbers, and flat laps

Covington Lapidary Engineering (www.covingtonlapidaryengineering.com)

Lapidary Discounts (www.lapidarydiscount.com)

Motors, speed controllers, pillow blocks, etc.

Surplus Center (www.surpluscenter.com)

Please feel free to send your questions and comments about any of my columns to Shop Talk, 25231 Pericia Dr., Mission Viejo, CA 92691 or quappelle@cox.net.



Ethiopian Opal from the newly discovered deposit in the Wello Province...



EW0-2: "A" grade opal is sizes ranging from 2-5 grams each. Approximately 10 pieces to the ounce. Bright multi-color crystal opal ...great for medium pendant sized stones. \$200.00 per 1/2 ounce, \$350.00/ounce or 2 ounces for \$600.00 plus \$10.00 shipping.



EWOBM-1: "B" grade opal is sizes ranging from 2-5 grams each. Approximately 10 pieces to the ounce. Bright multi-color crystal opal ...great for pendant & ring sized stones. Not as bright or as good a yield as "A" grade ...but certainly VERY NICE opal for the price!! \$185.00 per ounce, 2 ounces for \$325.00 or 4 ounces for \$600.00 plus \$10.00 shipping.

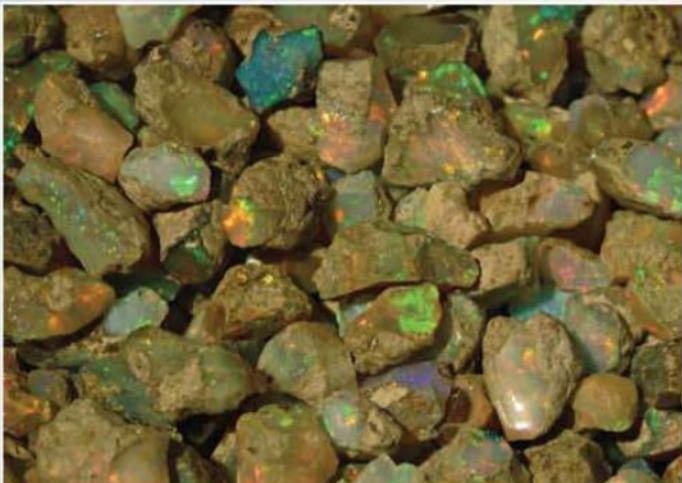

EW0AS-1: "A" grade opal is sizes ranging from .5-2 grams each. Approximately 20-25 pieces to the ounce. Bright multi-color crystal opal ...great for ring sized stones. \$175.00 per ounce, 2 ounces for \$300.00 or 4 ounces for \$550.00 plus \$10.00 shipping.

The best way to describe the play-of-color characteristics of this opal is a delightful combination of bright, multi-color opal coming from 3 sources: Mexico, Brazil and Australia. Wello is a very clear crystal opal with the stability and brightness of top gem Australian precious opal. But be forewarned ...when you cut your first piece of this opal you are going to want to cut more. The Wello opal is available in Grade "A" and Grade "B" in 3 sizes: .5gm-2gm, 2gm-5gm and 5gm-9gm. Keep an eye on our website for other grades and sizes of this opal coming soon.

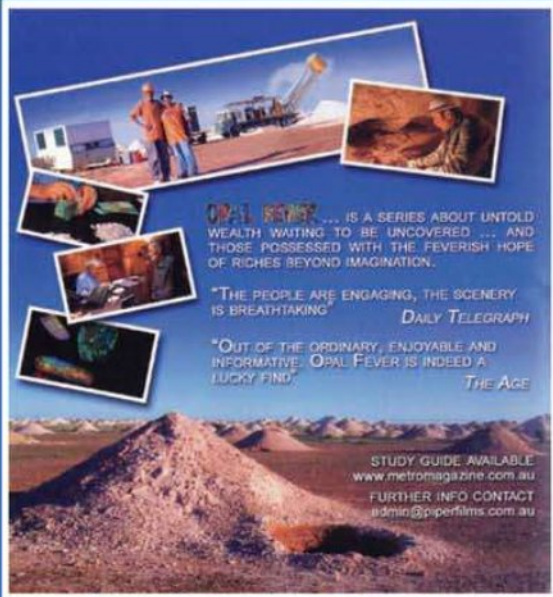

Opal Fever video: A wonderful documentary video on Australian opal mining and opal trading ...as well as opal mine rescue. This has only been available in Australia as a PAL format DVD, until recently being converted to NTSC for viewing here in the USA.

... IS A SERIES ABOUT UNTOLD WEALTH WAITING TO BE UNCOVERED ... AND THOSE POSSESSED WITH THE FEVERISH HOPE OF RICHES BEYOND IMAGINATION.

"THE PEOPLE ARE ENGAGING, THE SCENERY IS BREATHTAKING" *DAILY TELEGRAPH*

"OUT OF THE ORDINARY, ENJOYABLE AND INFORMATIVE. OPAL FEVER IS INDEED A LUCKY FIND." *THE AGE*

STUDY GUIDE AVAILABLE
www.metromagazine.com.au
FURTHER INFO CONTACT
admin@paperfilms.com.au

The movie production crew take you down into a working opal mine to see beautiful gem grade opal actually uncovered during shooting. The emotions of finding this rare gem quality of opal are very evident on the faces and in the voices of the actual opal miners ...many of whom I've met in Coober Pedy during my annual buying trips. This is the most magnificent video on opal mining I've seen ...truly amazing footage. The opal seen in this video will take your breath away. If you like opals ...you are guaranteed a superb movie that will have you riveted to the screen. 4-27 minute segments originally aired on Australia's ABC TV. \$29.95 plus \$6.00 shipping.

The Village Smithy Opals, Inc.

P.O. Box 21704, Billings, MT 59104-1704

Phone: 406-651-4947 Mobile: 406-208-2577

E-mail: vsmithy@bresnan.net

Website: www.villagesmithyopals.com



"America's marketplace for fine jewelry, gems, beads, crystals, and treasures from around the world."

www.gemfaire.com

info@gemfaire.com (503) 252-8300

2010 SCHEDULE

- JAN. 8, 9, 10 DEL MAR, CA
- JAN. 15, 16, 17 SANTA ROSA, CA
- JAN. 22, 23, 24 HILLSBORO, OR
- JAN. 29, 30, 31 SAN RAFAEL, CA
- FEB. 5, 6, 7 ROSEVILLE, CA
- FEB. 12, 13, 14 SANTA MONICA, CA
- FEB. 19, 20, 21 SANTA BARBARA, CA
- FEB. 26, 27, 28 COSTA MESA, CA
- MAR. 5, 6, 7 DEL MAR, CA
- MAR. 12, 13, 14 PLEASANTON, CA
- MAR. 19, 20, 21 HILLSBORO, OR
- MAR. 26, 27, 28 SALT LAKE CITY, UT

Last _____ First _____

Address _____

City _____ State _____ Zip _____



Must present original coupon. Photocopies not accepted.

RG1/10

Show Dates from page 10

30-13—TUCSON, ARIZONA: Show, "Arizona Mineral and Fossil Show"; Martin Zinn Expositions LLC; The InnSuites Hotel (475 N. Granada), The Mineral & Fossil Marketplace (1333 N. Oracle Rd.), Quality Inn (1025 E. Benson Hwy.), and Ramada Ltd. (665 N. Freeway); 10-6 daily, final day 10-5; free admission; more than 400 dealers from all over the world, Artists' Gallery (InnSuites Hotel); contact Martin Zinn Expositions, P.O. Box 665, Bernalillo, NM 87004-0665, fax (303) 223-3478; e-mail: mzexpos@aol.com; Web site: www.mzexpos.com

FEBRUARY 2010

4-12—TUCSON, ARIZONA: Business to Business Gem Trade Show; Gem and Lapidary Wholesalers Inc.; Holiday Inn Palo Verde/Holidome, 4550 S. Palo Verde Rd. (I-10 at Palo Verde Rd.); daily 10-6, last day 10-3; contact Gem and Lapidary Wholesalers Inc., P.O. Box 98, Flora, MS 39071-0098, (601) 879-8832; e-mail: info@glwshows.com; Web site: glwshows.com

5-7—ROSEVILLE, CALIFORNIA: Show, "Gem Faire"; Gem Faire Inc.; Placer County Fairgrounds, 800 All America City Blvd.; Fri. 12-7, Sat. 10-6, Sun. 10-5; \$5 weekend pass; contact Yooy Nelson, (503) 252-8300; e-mail: info@gemfaire.com; Web site: www.gemfaire.com

5-8—TUCSON, ARIZONA: 9th annual show, "Westward Look Show 2010"; FineMineralShow; Westward Look Resort, 245 E. Ina Rd.; Fri. 10-6, Sat. 10-6, Sun. 10-6, Mon. 10-5; more than 25 of the world's top dealers, "Collector Day" Sat., featuring Will Larson's private collection, Sun. evening cocktail hour, mineral art gallery, and artist panel, including Eberhard Equit, Hildegard Könighofer, Susan Robinson and Wendell Wilson; contact Dave Waisman, P.O. Box 8543, Spokane, WA 99203; Web site: www.finemineralshow.com or www.westwardminerals.com

12-14—KIRKWOOD, MISSOURI: Show; Cabin Fever Productions; Kirkwood Community Center, 111 S. Geyer; Fri. 4-9, Sat. 10-6, Sun. 10-4; adults \$3, seniors and students \$2, children 12 and under free; jewelry, gems, rocks, minerals, fossils, attendance prizes; contact Melanie Vick, 1801 Barbary Way, Swansea, IL 62226, (618) 830-8471; e-mail: cabinfeverprod@aol.com; Web site: www.cabinfeverproductions@yolasite.com

12-14—SANTA MONICA, CALIFORNIA: Show, "Gem Faire"; Gem Faire Inc.; Santa Monica Civic Auditorium, 1855 Main St.; Fri. 12-7, Sat. 10-6, Sun. 10-5; \$5 weekend pass; contact Yooy Nelson, (503) 252-8300; e-mail: info@gemfaire.com; Web site: www.gemfaire.com

12-21—INDIO, CALIFORNIA: Show, "Riverside County Fair & National Date Festival"; San Geronio Mineral & Gem Society; Gem & Mineral Bldg., Bldg. #1, 46-350 Arabia St.; 10-10 daily; adults \$8, seniors \$7, children \$6; contact Bert Grisham, (951) 849-1674; e-mail: bert67@verizon.net

13-14—OAK HARBOR, WASHINGTON: 45th annual show, "Sweetheart of Gems"; Whidbey Island Gem Club; Oak Harbor Senior Center, 51 S.E. Jerome St.; Sat. 9-5, Sun. 9-4; contact Keith Ludemann, (360) 675-1837; e-mail: rock9@whidbey.net

19-21—SANTA BARBARA, CALIFORNIA: Show, "Gem Faire"; Gem Faire Inc.; Earl Warren Showgrounds/Exhibit Hall, 3400 Calle Real; Fri. 12-7, Sat. 10-6, Sun. 10-5; \$5 weekend pass; contact Yooy Nelson, (503) 252-8300; e-mail: info@gemfaire.com; Web site: www.gemfaire.com

20—PHOENIX, ARIZONA: Annual show, "Family Fun Day at the Museum"; Maricopa Lapidary Society; 1502 W Washington St.; Sat. 10-4; free admission; dealers, demonstrations, kids' activities, gold panning, metal detecting; contact Laurette Kennedy, (602) 771-1611 or (602) 738-2552; e-mail: lkennedy11@aol.com

20—UPPER MARLBORO, MARYLAND: Show; Southern Maryland Rock & Mineral Club; The Show Place Arena, 14900 Pennsylvania Ave.; Sat. 10-4; ages 7 and up \$3, 6 and under free; vendors, exhibitors, minerals, fossils, gems, original jewelry designs, demonstrations, faceting, bead stringing, wire wrapping, gold panning, children's crafts, door prizes; contact Michael Patterson, 11000 Thrift Rd., Clinton, MD 20735, (301) 297-4575; e-mail: michael.patterson@pgparks.com; Web site: www.freewebs.com/smrmc/

20-21—ALBANY, NEW YORK: 17th annual James Campbell Memorial Gem, Mineral, and Fossil Show and Sale; New York State Academy of Mineralogy, Capital District Mineral Club; Museum, Empire State Plaza, Madison

continued on page 52

4th Annual

Tucson Electric Park

RV Gem Show

(A juried Rock, Gem & Jewelry Show)



Jan. 30 - Feb. 14, 2010



Cabs & Slabs
Jewelry • Rough Rock
Beads • Lapidary Supplies
Fossils • Wire Wraps
Faceting Rough
Minerals

Retail & Wholesale
Demonstrations
Food Court
Free Parking & Admission
Dry Camp Area (\$10 per day)

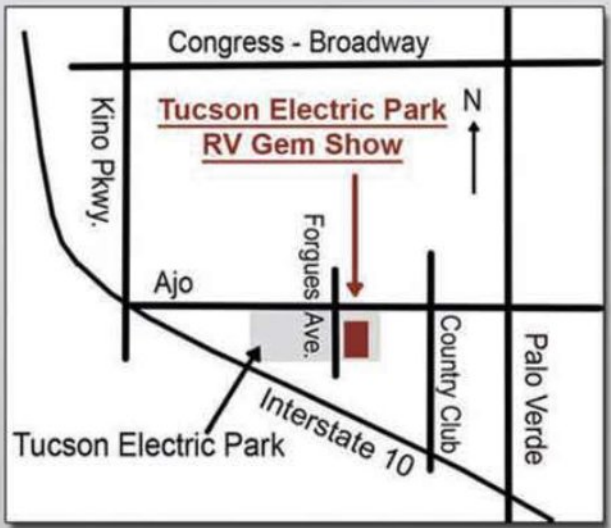

Open Daily 9:30am to 5:30pm

Location: Kino Sports Complex
2500 East Ajo Way, Tucson 85713
Adjacent to the well known
"Tucson Electric Park Gem & Mineral Show"

Dealer Day January 29th!
If you are an exhibitor at one of the other Tucson shows, come see our vendors **before** your own show begins!
We are open Friday, January 29th from 9:30am to 5:30pm.

Want to exhibit?
Call 800-983-0133

email: teprv.gemshow@yahoo.com
TEP RV Gem Show, PO Box 246, Cortaro, AZ. 85652

The “FERRARI” PANS

New Competition
Gold Pans Set
Recovery Records

Story by Marc Davis

Those pans are so fast we nicknamed them ‘Ferrari pans!’” exclaimed competition panner and 15-time medalist, Carol Ebbitt, on her return from the 2009 World Gold Panning Championships in Biella, Italy. “At the Worlds, it’s tough to be competitive unless you have one,” she continued. “The USA team had one medalist, Joyce Mason. She did really well and came home with a bronze in the Veteran’s division. Of course, she was using a ‘Ferrari’, too.”



MARC DAVIS PHOTO
Molded plastic allows manufacturers to easily add ruffles and other gold traps to their pans.



MARC DAVIS PHOTO

Carol Ebbitt shows off the European pan that ruled the 2009 World Gold Panning Championships in Biella, Italy.

The gold pans Ebbitt was describing to me are the new, radically redesigned pans that have set world record times when in the hands of experienced competitors at international gold-panning competitions. The pans have an extremely flat profile compared to a standard gold pan. “The ‘Ferraris’ are about twice as fast as the traditional American pan,” interjected Don Robinson, a three-time USA national champion. “Winning times with the new pans can be well under two minutes. Their times are about half of what U.S. competitors with regular pans are turning in.”

The World Gold Panning Championships are the Olympics of the competitive gold-panning world. There are 20 member countries in the World Gold Panning Association (WGPA), which sponsors the championships, an annual event that started in 1977. At the World Championships, competitors are given a bucket filled with a measured amount of dirt. Hidden in the dirt are a few tiny flakes of gold. According to the rules, the flakes must be at least 1 millimeter across. A millimeter is considerably smaller than one-sixteenth of an inch. The object is for the competitors to pan out all the gold in the least amount of time without missing any of the minuscule flakes. For each flake missed, there is a three-minute time penalty. The winning time this year in the men’s proficient division was a blistering one minute, thirty-eight seconds. The ladies weren’t far behind, with the winner posting a one minute, forty-two second time.



MARC DAVIS PHOTO

I found that the Australian competition pan works well in calm water, but could not handle swifter moving currents in other parts of the river.



MARC DAVIS PHOTO

Users of steel batea pans, such as this one from the Czech Republic, took home several medals from the 1998 World Championships in Coloma, California.

When it comes to competition of any sort, elite competitors are looking for an edge. Many world-class competitive gold panners are searching for any advantage they can get, so long as it is within the rules. New technology and materials have made it easier for these competitors to experiment with and change gold pan design in order to get that edge. The results are the new, unusually designed gold pans and the smoking fast panning times that we see in competition today.

Looking back, gold pan design in the United States stayed relatively unchanged for many years. Pans used in early gold fields were often just a kitchen pan. It wasn't long, however, before commercially available steel pans were being utilized. The early pans had relatively steep, smooth sides and a large-diameter, flat bottom. These pans were much the same as steel pans that are still available today.

A variation of the traditional wide-bottom steel gold pan is a version called the drop-bottom pan. It has a smaller-diameter bottom than a traditional pan and consequently wider sides. The sides are pitched at a shallower angle than those of the traditional pan. The bottom of the pan is depressed, leaving a ridge where the side and the bottom come together. This ridge helps retain fine gold. It also results in the bottom of the pan being lower than normal, hence its name of the "drop-bottom" pan.

Another version of the traditional gold pan, used mostly in days gone by, is constructed out of copper and coated with mercury. The fine gold coming into contact with the mercury would form an amalgam in the pan, thus capturing what otherwise might escape. Mercury, often referred to as "quicksilver" in the old days, is used much

less frequently today due to environmental concerns and known health hazards.

In more modern times, plastic became a popular material for the construction of gold pans, allowing manufacturers to easily add riffles and other gold traps. Now, pans are being made in a variety of different shapes, as well. U.S. manufacturers, however, have not picked up on the recent trend in competition gold pans. The flat-profile designs that are garnering the medals in international competition are all manufactured outside this country, as far as I can determine.

When the World Gold Panning Championships came to Coloma, California, in 1998, there was a hint that changes were afoot in terms of competition gold pan design. At that time, the steel batea pans used by some European teams set the standard. The bateas, essentially wide-mouthed inverted cones, were unlike anything used by the American competitors. There was no flat bottom to these pans at all. In order for them to sit upright, the bateas had to be placed in stands. The panning motion used with these pans was a circular action that differed from the technique used with traditional American pans.

The bateas were the forerunners of the pans that are being used in international competition today. The pans now turning in the fastest times utilize the same circular panning motion that made the bateas work

so well, but the new competition pans are considerably improved, being much flatter and constructed out of different materials, typically fiberglass or plastic. Some plastic versions have proven to be a bit too flexible when the pan is filled to capacity. A great deal of stiffness is required in order for these pans to hold their proper shape when loaded with dirt.

Ebbitt explained that competitors from several countries have developed their own versions of these speedy competition pans. The new pans vary somewhat in design, but do share some common traits. As previously mentioned, they are much flatter than the traditional U.S. version of the gold pan. The new flat pans also have a set of fine ridges or spiral riffles that cover almost the entire pan. The South African version, named the "Black Mamba" by its manufacturer, after the deadly snake, has a relatively small drop-bottom and large, nearly flat sides. The sides have a series of molded in, shallow, closely spaced, circular ridges. The circles start near the outside rim of the pan and continue in ever-smaller diameters all the way to the lip of the drop bottom.

The version of the competition pan used by the Australian team that captured a poke full of medals at past world competitions is not quite as flat as the Black Mamba. The Australian pan has a bit more of a bowl shape and has spiral ridges that lead from the outside rim back to the center of the pan.

The pan that took home the medals in the 2009 championships is of a European design that is similar to that of the Black Mamba, but with deeper, sharper ridges. This is the pan that was also used by U.S. bronze medalist Mason.

A Whole World of Fine
PEARLS

All Kinds of Better Natural Stone
BEADS



All Sorts of Calibrated Better
GEMSTONES

Useful Jewelry & Beading

TOOLS



www.StachuraWholesale.com

- order on-line securely
- request Wholesale Catalog
- view photos of new items

Direct Importers – Best Prices since 1955

Joseph P. Stachura Co., Inc.
435 Quaker Highway, Rt. 146A
Uxbridge, MA 01569

T: 508.278.6525 F: 508.278.9458

contactus@StachuraWholesale.com

Visit our Showrooms – Wholesale Only

Facet Shoppe

Lapidary Equipm Ent
and Supp LiES

Custom Faceting Service.
Your One-of-a-Kind Specialist!

Fac Et r ough &
cuStom cut gEmSton ES

PO Box 534, Burley, WA 98322

or e-mail: facet@gemcutter.com

(360) 443-6313

www.gemcutter.com

EARTHWORKS®

GEmS min ERAI S FOSSIl S

- Gold Panning Bags – Guaranteed gold
60mg 7.95, 3/19.95; 100mg 9.95, 3/25.95
- Gem Mining Bags – Ruby, Emeralds or
Sapphire 7.95ea, 3/21.95 mix/match
- Gold Pan – 10" plastic w/riffls 3/9.95
- Salt Lamp w/cord 6" tall \$23.95
- Polished stones – 10 different w/ID 3.95
- Fossils – 3 different w/ID 2.95, 4/9.95
- Meteorite Pendant w/cord 8.95
- Prices plus S/H Catalog \$1

P.O. Box 2067, Round Rock, TX 78681
Pat@Earthworks.net 512-255-2844

The "Ferrari" Pans from page 23



Marc Davis photo

My field test of an Australian competition pan netted me some small pieces, but not much fine gold.



Marc Davis photo

Ebbitt has won 15 medals in various gold panning competitions with a more traditional style of gold pan.

The motion used to work these pans is not what the typical prospector in the United States is used to. The average user of a traditional American pan is seated beside a river on an upside-down bucket or rock. He uses a side-to-side type of motion to settle the gold toward the bottom of the pan, then he dips the pan in the water and uses a forward-and-backward motion to wash away the top layers of dirt. These motions are alternated to keep moving the gold deeper into the pan, while washing the top layers of dirt away until only a small amount of gold and sand remains.

In contrast, the foreign competition pans are designed for panners standing in a shallow tub of calm water called a panning pool. The panner bends over at the waist, holding the pan in the water with outstretched arms. He then moves the entire pan in a circular motion. This circular action concentrates the gold toward the center of the pan while simultaneously moving barren material out of the pan.

In competition, Robinson told me, "The new pans have another advantage over the traditional pan. All the dirt in a single bucket can be placed in the pan in one shot." The competition pans are designed close to the 50-millimeter maximum diameter allowed by WGPA rules, and because these pans

utilize a circular motion to work the pay dirt down to concentrates, these pans can accommodate an entire measured bucket of dirt. U.S. competitors generally have to add their bucket of dirt to their pan in portions. The result in competition panning is a big advantage to the new pans.

With the new-style pans dominating international competition, there were concerns that the traditional pan would disappear from the scene. In an effort to preserve the status of the gold pan as we know it, some local competitions now have a category called "traditional pan".

With all the seeming advantages of these newly designed competition pans, one must ask is it time for the average panner to trade in his old faithful for one of these new hot rod pans? "I don't think so," states Robinson, who points out that competitors at the World Championships do their work in a shallow pool of confined, static water. By contrast, the average panner in the gold fields is often working in a fast-moving river or stream. Don's theory is that the moving water could inadvertently sweep gold out of the flat competition pan, a phenomenon that is less likely with a steep-sided, more traditional pan.

In order to test this theory, I took an Australian-designed competition pan out to

BelOMO 10x Triplet Loupe

World's most popular loupe!

10 times magnification ratio
3 achromatic optical lenses bonded together
Larger viewing area than most loupes
Focal distance: 1.1 inch
Linear field of view: 0.67 inch
Size: 1.54 x 1.1 x 0.98 inch
Weight: 2.1 oz.



Distributed in North America by US Geological Supply

<http://www.belomo.us>

belomo@usgeologicalsupply.com

877-4BelOMO (877-423-5666)

Amateur Geologist

*Supplies for the recreational
geologist and rockhound*



Books - hundreds of titles - most at 30% off
Estwing rock hammers and tools
Loupes - BelOMO & Bausch & Lomb
Geology maps & charts
Educational rock & mineral collections
Hardness pick sets
Vests with pockets galore
Ultraviolet lights
Rock tumblers
Rockhound stuff for kids
Novelties



Discounted internet prices!!!

www.amateurgeologist.com

A Rockhound's Tour of England
 CRIZMAC Travel Adventures



A Rockhound's Tour of England
 May 4-14, 2010

Join *Rock and Gem* editor Bob Jones for this special tour of England arranged specifically for rockhounds and mineral enthusiasts!

Complete itinerary and fees available at www.crizmac.com or call Kitty Williams at **1-800-913-8555**.

Reserve Your Space Today!

A collaboration between CRIZMAC and *Rock and Gem* Magazine.

BOXES
THE FOOTHILLS INC.



Minerals — Mineral Boxes
 Mineral and Stock Boxes Since 1975

201 N. Copia St., El Paso, TX 79905
 U.S. Ph 915-534-7095
 Cell Ph 915-726-1554
TheFoothillsinc@yahoo.com

Mineral & Fossil Marketplace - Tent #14

TFGCollector

TFGCollector is the BEST cataloging software available! With TFGCollector you can use your own cataloging numbers, save pictures, notes — all kinds of information for rocks, minerals, and fossils! Even keep track of clubs, contacts, dealers, and collecting sites! Only \$24.95!

Go to www.TFGCollector.com or call (866) 679-9284 for more information and to order today!



Marc Davis photo

Plastic pans in the United States come in many different styles and colors.

one of the gold-bearing rivers in my area. I figured that the Australian pan, with its slightly higher sides, would be more likely to retain the gold than the super-flat designs. I was hoping for success, thinking that if I could pan twice as fast, I would be able to do more pans in a day, thereby increasing my overall gold recovery.

Once out at the river, I located a calm, flat section of water. I sifted some potential pay dirt from a nearby gravel bar through a 1/2-inch mesh screen and dumped the graded material into the Aussie pan. Standing in water a bit more than ankle deep, I bent over to hold the pan in the water and began swirling the pan. I was amazed at how quickly the dirt started to disappear.

A couple of test pans later, my back began to feel the effects of the bent-over position required to use this speedster. I also found that, while I could get the bulk of the material out of the pan quickly, it would take some practice to learn how to get down to just the fine gold and a little sand.

Having not recovered much gold from the gravel bar, I began looking for likely spots in which gold would be hiding. I walked the river searching for bedrock crevices, boulders, and other gold traps. Unfortunately, these locations were a significant hike away from my calm spot in the river; the water nearby was moving rather rapidly. The time it would take to traverse the distance to the best panning spot would more than negate the time I would save using the faster pan. Therefore, I decided to try panning where I was.

I selected the slowest section of water that was not too far away from my diggings. I began swirling the pan as I had previously,

only to find that the flat pan acted like an aquaplane in the moving water. If the nose of the pan angled a little too deeply into the river, the current would grab it and push it down, causing the dirt in the pan to swirl and move in ways I had not intended. Some of this action could have been the result of my inexperience with this pan. Even Ebbitt, who has garnered 15 medals in panning competitions, acknowledges that she has yet to master the motion of these new pans. "I can do it," she said, "but not fast enough for competition."

For now, I plan to stick with my traditional gold pan when I'm out at the river prospecting. Traditional pans work well, even in a mild current. They are relatively inexpensive, readily available, and durable. That being said, I'll also be practicing with my Aussie pan. I have a smaller version of the pan that may be easier to control and I will give it another try in the river when I'm more experienced with it.

For those who are interested in competition gold panning, unfortunately, the new pans are difficult to obtain. All the manufacturers that I am aware of are located overseas. These pans are also expensive and can run \$75 to \$150 or more.

For now, our homegrown pans are still competitive in the United States, where the flat pans are relatively unknown in competition. On the international circuit, however, the flat pan is the key to the future. Hopefully, competitions will continue to have a "traditional pan" category, but in years to come, I believe those who do not switch to the flat pan will be left in the wake of those who have.

Readers who would like more information about the World Gold Panning Championships can check out the WGPA at www.worldgoldpanningassociation.org. Those who are interested in acquiring a Black Mamba gold pan or an Australian competition pan can find information at www.pilgrimsrest.org.za/pan.htm or www.madog.com/gold/Gold-Pans/index.html.



Joe Car Doza photo

Don Robinson, a three-time national champion, took home two gold medals and one bronze from the recent California State Championships.

HOUSTON

FINE MINERAL SHOW

APRIL 30TH - MAY 2ND, 2010

DEALERS

Kristalle
Inner Earth
JBF Minerals
Rocksaholics
GTA Minerals
Evan A. Jones
Mineral Décor
Mineral Search
Crystal Monster
eShop-Minerals
The Arkenstone
Crystal Classics
Lehigh Minerals
Lexcel Minerals
Venerable Stone
Awake Aesthetics
Miner's Lunchbox
By Nature Gallery
Dave Bunk Minerals



DEALERS

Judy and Richard Rome Jewelry Designs
Laurent Thomas - Polychrom France
William Metropolis Fine Minerals
Crystal Springs Mining Company
Horst Burkard Minerals Fossils
Mineralien Fossilien Galerie
Columbia Trading Company
Adam's Mountain Minerals
Gallery of Lapidary Artists
The Sunnywood Collection
Green Mountain Minerals
Alpine Mineral Company
Dan and Diana Weinrich
MK Gems and Minerals
Joe Budd Photography
Tucson Store Fixtures
Paul Staber Minerals
Exceptional Minerals
Don and Gloria Olson
Petaca Fine Minerals
Vasconcelos - Brazil
Mineralien Zentrum
The Uncarved Block
Wright's Rock Shop
Graeber and Himes
Edward's Minerals
Top Shelf Minerals
Atomic Perfection
Wendy's Minerals
Majestic Minerals

For more information contact Dave Waisman at 509.458.2331 | www.FineMineralShow.com

Embassy Suites Hotel near The Galleria – 2911 Sage Road, Houston, TX

Classic Minerals of GREAT BRITAIN

Superb Specimens Were Mined in Overwhelming Quantities

The mines of Great Britain have produced a remarkable number of superb species that are considered classic today. Each has been mined in large—some would say overwhelming—quantities. Many were the first of a species to be found, while others are considered the best example of a species ever found. Any mineral museum, privately owned collection, or large fluorescent mineral display will have a good representation of the quality, quantity and variety of superb UK minerals.

I'm sure you can name many of the more common species from England, including calcite, fluorite, barite, siderite, and even quartz. You may not realize how many uncommon to rare species are found there, including bourmonite, alstonite, witherite, lanarkite, bornite, torbernite, leadhillite, campylite, chalcophyllite and olivenite. These species, most of which are worthless as ore, were encountered by miners in pursuit of ore minerals such as hematite, bornite, chalcocite, cassiterite, chalcopyrite and sphalerite.

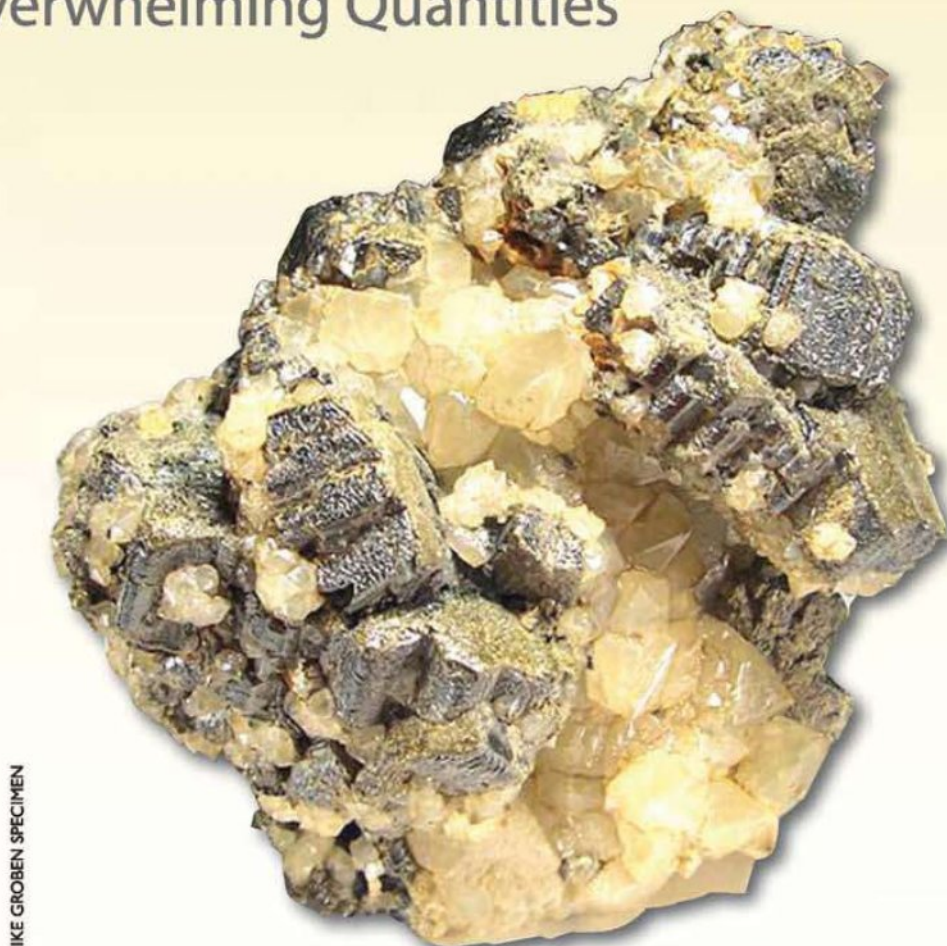

MIKE GROBEN SPECIMEN

Fine cogswheel bourmonite from the Herodsfoot Mine in Cornwall is often associated with quartz.

Since the mines of England are among some of the earliest formal mining operations ever attempted—they date back to Roman Britain (AD 43-410)—it is to be expected that their minerals are among some of the earlier described and identified species.

One of the best known English minerals is fluorite. The English call it fluorspar, and it was found in remarkable quantities during mining. English fluorite is world renowned as *the* fluorescent mineral. Though its natural hue may be green, violet, yellow or something in between, English fluorite glows a remarkably bright blue under long-wave ultraviolet (UV) light. Students of fluorite now know the cause of most fluorescent responses in fluorite from England: rare earth elements!

At the bottom of the Periodic Table of Elements is a group of elements that is

separated from all the others. They boast weird names like praseodymium, europium, gadolinium, dysprosium, ytterbium and samarium. Studies have shown that members of this rare earth group are found as trace elements in calcium fluoride (fluorite) from England and cause their wonderfully bright UV response.

England's fluorites are single cubes ranging from under an inch to 4 inches on an edge and groups of cubes a foot or more across. They came mainly from iron and lead mines in Cumberland; the mines of Cornwall contributed much smaller quantities. Vast amounts of well-crystallized fluorites from the Cumberland mines are still around, though mining has virtually ceased. An exception is the Rogerley Mine, which is currently producing choice specimen-quality green cubes in quantity.



Fine yellow Cornish fluorite is quite different from typical violet Cumberland fluorite.



Modified cubes of galena on purple fluorite are classics from Weardale, Cumberland, England.



This superb example of a leafy Cornish chalcocite shows the mineral's typical peacock tarnish.

The Cumberland mines were operated for hematite, galena and sphalerite to be smelted into iron, lead and zinc. Not only did the mining of these important minerals feed the Industrial Revolution in England, it created a vast collector's pool of minerals. English galena, for example, seldom formed in simple cubes. The vast majority of these lead sulfide crystals were modified octahedrons. Some have faces that are concave. Most galena was closely associated with fluorite and calcite, so it was the mining of this ore mineral that resulted in the vast quantities of fluorite and calcite also being extracted and saved.

English hematite is truly a classic. The more common specimens seen are large, black, botryoidal masses; their undulating surfaces are often quite lustrous and showy. Other such masses are reddish in color, due to slight surface oxidation. These are referred to as "kidney ore" because of the form and color. Masses weighing tons were encountered during mining. The hematite was found in such quantities that every museum and any private collector who wants to can still obtain a fine specimen from these now-closed mines.

Perhaps the more attractive hematite from Cumberland is that which occurs as tiny, bright, black, bladed crystals completely covering massive botryoidal hematite, with gemmy, doubly terminated quartz crystals within and on the bladed hematite. These

are particularly attractive, especially when a bit of the hematite gets in and under the transparent quartz, tinting it blood red.

The most common and most appealing gangue mineral from these mines was calcite. So many mines produced calcite that it would be nearly impossible to list them all, but the mines of the Frizington area of Cumberland produced the most calcite. Superb examples of English calcites, many of them showing lovely twinning, can be seen in every major museum and major private collection in the world.

Twinned English calcites are the ones most desired by collectors. Of the twins, those resembling a heart are probably the most eagerly sought, especially if they have a light dusting of reddish hematite on them! Other twins look like rabbit ears or are penetration twins of remarkably sharp form. No collection of English minerals is complete without a selection of calcites showing the immense variety of twinning of which the mineral is capable. This is why the English calcites are true classics.

English barite is found largely as a gangue mineral, though it can have ore value. It occurred abundantly in Cumberland (now Cumbria) at Alston Moor, Cleator Moor, Dufton and Frizington. Frizington was best known for exceptional calcite crystals, clusters and twins.

Remarkable wedge-shaped blades of barite of enormous size and in clusters

too heavy to lift, were once found in these lead and iron mines. Though the barites are opaque and seldom brightly colored, their huge crystal length, sometimes a foot or more, and specimen size make English barites very showy display specimens. The largest reported barite is a 100-pound single colorless blade from Dufton, Cumberland!

One of the more interesting varieties of English barite is opaque, wedge-shaped crystals of a nondescript cream color whose edges are a solid brick red to brownish red due to iron oxide (hematite). Sometimes, this color bleeds into the barite crystal faces, giving them a colorful outline.

The finest barites do have color. Lovely robin's egg blue barites come from Frizington and rich yellow to brown crystals are from Mowbray. Some say that blue barite will fade in sunlight, while others have shown the color can be enhanced by exposure to the sun's rays. I suspect both conditions occur depending on the individual specimen and mine source.

A source of colorless, almost gemmy barite is near the town of Knoch, Westmoreland. The blades are thick and tabular and they occur in subparallel clusters, with whitish bases that grade into colorless, gemmy terminations.

Still another really unusual form of barite is found at New Haven, Youlgreave, Derbyshire. The barite looks somewhat like petrified wood, but is actually stalac-

MILS®

Minnesota Lapidary Supply

**"YOUR LAPIDARY
GENERAL STORE"**

For EQUIPMENT and SUPPLIES

Some of the Equipment and Supplies we stock:

- Tumblers • Arbors • Drills
- Abrasives • SiC Wheels • Laps
- Polishes • Diamond • Books
- Saws • Wheels • Cutting Oil
- Blades • Belts • Tools

Some of the many vendors we stock:

- Lortone • MK • MLS
- Estwing • Mini-Sonic • Diamond
- Calway • Hughes • Pacific
- Foredom • Raytech • Cascade
- Lapcraft • Gryphon • Tru Square

Please contact us for our FREE Catalog !!

Minnesota Lapidary Supply

201 N. Rum River Drive

Princeton, MN 55371

Ph/Fax: (763)-631-0405

e-mail: sales@lapidarysupplies.com

Our Hours are:

Sun. & Mon. --- Closed

Tues. thru Fri. --- 9:00 a.m. to 5:00 p.m. CST

Sat. --- 9:00 a.m. to 4:00 p.m. CST

GEORGIA ROCK SHOP

*Crystals, Minerals, Fossils,
Slabs & Cleaning Guns.*

Open 7 days: 8am - 9pm

1231 Bartley Road, Lagrange, GA 30241

WEEKEND TRIPS TO LOCAL CRYSTAL MINES!

Dig your own:

Aquamarine, Star Rose Quartz,

Tourmaline, Quartz Crystals

www.digforcrystals.com

Curiosities from
the
Earth

rare and one-of-a-kind
gems and crystals our specialty

GEM-FARE

P.O. Box 213, Pittstown, NJ 08867

(570) 449-4577

E-mail: gf@sprintmail.com

Classic Minerals of **GREAT BRITAIN** from page 29



LEFT: Fine needles of olivenite in vuggy iron oxide are typical of the olivenite encountered during mining in Cornwall.

BELOW: This pre-1800 specimen features sharp, small, blue crystals of lironite on fibrous olivenite.

titic. Small slices in various shades of brown have been polished and sold for years. Some of the stalactite sections are kept intact, with only the end polished to show the banding that is typical of any stalactite growth.

The most exciting minerals to come from England are the secondary phosphates and arsenates. The Cornish mines produced arsenic as a byproduct of copper and tin, so the arsenate radical was readily available to form such minerals as lironite, olivenite, chalcophyllite and clinoclase, all of which occurred in sufficient quantities to constitute collectible species.

The lironite from Wheal Gorland is the world's best. The lovely, rich blue crystals in small vugs were easy to spot. The largest known specimen is a 2-inch blade in the Philip Rashleigh collection, displayed at the Royal Cornwall Museum in Truro. Local collections of note contain many lironite specimens, and specimens do show up for sale once in a while.

The clinoclase from the Cornish mines are the world's best. They occur in rich, dark-green, bladed clusters. The finest of these are also contained in the Rashleigh collection. The best are complete spherules nearly 2 inches across on matrix.

Chalcophyllite is a lovely, bladed copper arsenate mineral that occurs in tight clusters. The crystals show a high, pearly luster. Individual clusters are seldom more than 1/4 inch, but form in tight fans of blades—a very attractive mineral.

Olivinite from Cornwall forms in near-velvety coverings on matrix. The crystals are needlelike and tightly packed, forming deep-green carpetlike coverings. The mineral tends to line depressions and cavities in the rock matrix.

Of course, Cornwall's chalcocite crystals are known around the world. The larger crystals reach 2 inches in length, but most occurred in tight, intergrown, bladed clusters and are well terminated. Crystals show fairly deep striations and may range from lustrous to dull.

Bornite is another world-class English mineral. The bulk of what is mined is massive, but where space allowed, small, sharp



RASHLEIGH COLLECTION,
ROYAL CORNWALL MUSEUM, TRURO

crystals in tight groups were found. The largest crystals are under 1/2 inch, and because of the tight intergrowth of crystals, few are seen in free-standing form. Bornite will often develop a distinctive rainbow sheen, making the mineral easy to identify.

A lovely suite of rare lead minerals was once collected from Leadhills, Strathclyde, Scotland, including leadhillite and lanarkite. Obviously, the deposit was the type locality for the mineral leadhillite. Crystals of leadhillite show a lovely, pearly luster and are most often white to cream in color. The larger crystals reach 1/2 inch. These are considered classic specimens. Leadhillite is also found in several other deposits, including the Red Gill Mine in Caldbeck Fells, Cumbria, England, and at Wanlockhead and Galloway, Scotland.

At the Fallowfield Mine, near Hexham, Northumberland, England, superb alstonite occurs in small, white, steeply pyramidal crystals. The crystals are often twinned and can be colorless, white or gray-yellow.

Witherite from the Fallowfield Mine is exceptional. The mineral actually occurs as an ore of barium, though collectors were most eager to acquire the lovely white pseudohexagonal crystals with distinct dipyramidal terminations. These rank as the world's best. The crystals show light horizontal striations, and under UV light, they fluoresce a good blue-white. The larger crystals exceed 1 inch in length. Witherite also occurs in fine crystals at Alston Moor and Nenthead, in Cumbria, where it occurs with galena, barytocalcite and calcite.

The mines of Cornwall actually produced quantities of uranium. Few uranium minerals have come from here, with the exception of torbernite (calcium, uranium phosphate). The mineral is a lovely grass



LASCO DIAMOND PRODUCTS, INC.

EXCELLENT QUALITY AND COMPETITIVE PRICING ON U.S. MADE DIAMOND CARVING TOOLS, CORE DRILLS, DIAMOND SLITTERS, DIAMOND POWDER, AND MUCH MORE ...

LASCO DIAMOND PRODUCTS MANUFACTURES DIAMOND TOOLS IN A WIDE VARIETY OF SHAPES AND SIZES, IN GRITS RANGING FROM 40 - 600.



**DIAMOND SLITTER
AVAILABLE SIZES:
7/8" RIM SAW
7/8" FULL COAT
1-3/8" RIM SAW**

NEW MICRO ULTRA CARVING MACHINE



UNLEASH YOUR CREATIVITY!

Your own imagination and Lasco's U.S. Made Diamond Carving Tools are all you need to create stunning works of art. Our diamond tools work great on all types of stone, metal, and wood. There are no limits to what you can create. For more information, or to request a free catalog, please call us at **(800) 621-4726** or **(818) 882-2423**, or Fax us at **(818) 882-3550**.

LASCO LASCO DIAMOND PRODUCTS

9950 Canoga Ave. #A8 * PO Box 4657 * Chatsworth, CA 91311

SEE US ON THE WEB AT
<http://www.lascodiamond.com/products>

Come see us in Tucson, January 30th - February 14th. Please call us at (800) 621-4726 for our booth location. Not able to make the show? Shop online at www.lascodiamond.com/products and use coupon code: TUCSON at checkout to receive a 20% Discount on your online order.

Silversmith Stamps
by
UNIQUE TOOL



DEALER INQUIRIES WELCOME

Since 1978, I have been hand grinding stamping tools for the silver jewelry trade. These stamps are hardened and tempered to approx. 58 Rockwell, (that's HARD!) blued, and satisfaction guaranteed. If you EVER are dissatisfied with any stamp we make, simply return it to us for a replacement, period. No questions asked.

- Hand-made in America from the best tool steel money can buy.
- \$6.00 each individual Stamp.
- Lifetime replacement warranty (*My lifetime, not yours*) ... no questions asked.
- 60 different designs available.

Shop the Website, or call or e-mail to request a catalog.
UNIQUE TOOL, P.O. Box 378, Rodeo, NM 88056
Call Toll-Free (800) 840-2434
www.thingswestern.com

Lamberton Rake

You'll LOVE it!



Use our Versatile Combination Rake / Hoe in the field, at home and for Hunting Gold!

For more information or to order see our website at HYPERLINK
"<http://www.lambertonrake.com>"
www.lambertonrake.com



GILMAN'S

YOUR COMPLETE JEWELRY AND LAPIDARY SUPPLY HOUSE

P.O. Box M, 726 Durham St.
Hellertown, PA 18055

PHONE (610) 838-8767
FAX (610) 838-2961

Classic Minerals of GREAT BRITAIN from page 30



LEFT: This torbernite from the Old Gunnislake Mine in Cornwall is probably the world's finest example of the mineral.

BELOW: Botryoidal hematite covered with microcrystals of hematite hosts transparent quartz with red spots of hematite showing through.



green and forms in micaceous blades, often on gray quartz. The best source for this mineral in Cornwall is the Old Gunnislake Mine at Callington.

Torbernite occurs in any number of mines in which uranium is either a minor or a more important ore. Collectors are very familiar with the extremely lovely, rich green, bladed clusters from Shinkolobwe, Africa. Few would argue that these African torbernites will reach classic status at some point. The Old Gunnislake torbernites, however, are already considered classic, as they occur in tight micaceous clusters of lovely color. Individual blades have been reported as up to 1 inch on an edge.

Recently, an old collection has been rediscovered in the cellar of an estate home, actually a faux castle. In that collection are what I consider the world's finest examples of Gunnislake torbernite, and perhaps the finest torbernites in the world. My visit to this lovely residence was in preparation for the May 4-14, 2010 CRIZMAC English mineral tour I'll be involved with (www.crizmac.com). In one of the highlights of the tour, we will view the collection and be hosted for lunch by the lord of the manor!

The finest of the torbernites in the castle collection are groups of crystals that approach 1½ inches on an edge. The major cluster measures over 4 inches across and has no matrix. It is a tight mass of bright-green inch-long crystals. Companion pieces in this collection also lack matrix, but make up for it with interlocking blade clusters whose crystals approach 2 inches on an edge! When I saw these torbernites, still held in that private collection, I was instantly convinced these Old Gunnislake Mine torbernites exceeded those from the Congo's Shinkolobwe copper mines.

Of all the classic minerals England has produced, the species that perhaps best represents the entire classic suite is Cornish boumonite from Wheal Boys and Wheal Newton in Endellion and the Herodsfoot Mine at Liskeard. ("Wheal" is the Cornish word for "mine".)

Enough specimens came out of Wheal Boys and the Herodsfoot Mine to create a market at the time of their recovery. These specimens are, for the most part, twinned,

and occur in handsome multiple crystal, sixing discs. The radial arrangement of the crystals creates squarish re-entrant angles between each twinned pair, so the overall effect is the appearance of a round, flat gear, hence the name "cogwheel twinning". The twins tend to be lead- to steel-gray and measure about 2 inches across, though a few approach 4 inches across. The crystal discs tend to stack in clusters at odd angles, so the notched edges of the twins are clearly visible.

The Herodsfoot specimens are usually seen with and on quartz. Some specimens have a bit of brown siderite attached, but most are associated with quartz. This thin crystallized layer of quartz can be carefully chipped away to expose more of the cogwheel form.

The Cornish boumonites are usually brilliant, but slightly rough surfaced, showing twinning lines. Groups range from small clusters measuring a couple of inches across to nice hand-sized crystal specimens that are very showy.

One important key to English classic minerals for collectors is availability. Most came out of the ground over 100 years ago, yet the majority were found in such quantities—especially calcite, hematite, fluorite and barite—that even today you can find specimens that are suitable for your collection. In addition, older English minerals emerge when a collection re-enters the specimen market.

Knowing about these classics helps you keep an eye out for something exceptional and historically important. Adding these English classics to your modern collection certainly adds a new dimension to it. Read more about these older species and be aware of them as you search dealers' tables for bargains! ♦



GEMMS

& GEM MINERALS



THE MAIN SHOW

WHERE THE BEST HAPPENS

TUCSON GEM & MINERAL SHOW™

FEBRUARY 11-14, 2010 • TUCSON CONVENTION CENTER

PRESENTED BY THE TUCSON GEM & MINERAL SOCIETY

AQUAMARINE ON SCHEELITE. XUEBAODING, PINGWU, SCHUAN CHINA. BILL LARSON COLLECTION. JEFF SCOVIL PHOTO.
AQUAMARINE 20CT AND 13CT. SANTA MARIA, BRAZIL. COURTESY OF PALAGEMS. MIA DIXON PHOTOS.

A New Prospecting Tool:

THE BLM GeoCommunicator



The GeoCommunicator is an interactive database that allows even small, independent prospectors the convenience of checking claim status remotely.

Story and Photos by Robert Beard

Identify Mining Claims from Your Computer

In the old days—meaning pre-Internet—it often took a significant effort to determine the status of a mining claim. It usually meant going to the county courthouse and the main office of the U.S. Bureau of Land Management (BLM) in the state in which the site is located to research, and this could be tedious and expensive for a mineral collector or small operator. Back when I was an independent gold prospector in New Mexico, this research took time away from finding new mines sites or working, and when I was working in remote areas, it was often very difficult to get to the courthouse. A trip to Santa Fe was almost as expensive as a prospecting trip.

Active mining claims are required by federal law to be clearly marked in the field, and all the corners and discovery monuments are supposed to be clearly labeled as such. In practice, however, I have found that this is rarely the case. It could be due to weather, vandals, or just plain carelessness by some claim stakers, but many mining claims I have seen in the field are either unmarked or so poorly marked that it is nearly impossible to know whether or not the claim was actually valid.

Fortunately, the BLM and the U.S. Forest Service (USFS) also recognized this as a problem, and saw an opportunity to do something about it. These two agencies combined their claim information and put it on an interactive database so that claim status could be checked remotely. This interactive database is known as GeoCommunicator (www.geocommunicator.gov). GeoCommunicator is sponsored by the BLM and the USFS and is the publication site for the Bureau of Land Management's National Integrated Land System (NILS).

The NILS is a joint project between the BLM and the USFS, in partnership with states, counties, and private industry, to provide solutions for the management of cadastral records in a Geographic Information System (GIS) environment. Cadastral records are maps and survey data that document the boundaries and ownership of land parcels. The NILS provides a process to collect, maintain and store parcel-based land and survey information that meets the common requirements of land title and land resource managers. The NILS project is being developed in four modules: 1) Survey Management (S), 2) Measurement Management (M), 3) Parcel Management (P), and 4) GeoCommunicator (G).

As an integral part of the NILS, GeoCommunicator is designed to provide geospatial data and products to the public. GeoCommunicator provides a central site for the distribution of geospatial data in three separate applications: 1) Federal Land Stewardship, 2) Land Survey Information System, and 3) Land and Mineral Use Records.

The Land and Mineral Use Records Viewer in GeoCommunicator allows you to search, locate, and map the BLM's land and mineral use records. GeoCommunicator can access an incredible amount of information in addition to mining claims: oil, gas, and geothermal leasing, coal and other solid mineral leasing, rights-of-ways (power, water, communications, roads, railways, pipelines, wind and solar energy), land use



Although this area of volcanic rocks appears barren of minerals, it was covered by many active lode and placer claims.

permits, mineral materials, community pits, land and mineral title, land withdrawals and classifications, range allotments and pastures, allotment reports, federal surface management agency boundaries, subsurface mineral estate, and the Public Land Survey System (township, range, section, lots, surveys). I have found GeoCommunicator to be useful when identifying easements and right-of-ways, especially for sites that are near major highways.

GeoCommunicator is free to use, and is a Web-based database. All you need to access it is an Internet Explorer 6 or higher browser (it will not work with a FireFox browser); pop-ups and scripting must be enabled on your browser. There is no software or hardware you need to purchase. The faster your Internet connection, the better, as GeoCommunicator has to process extremely large amounts of data.



This discovery monument is one of very few I have seen that are labeled with the claim name and number.

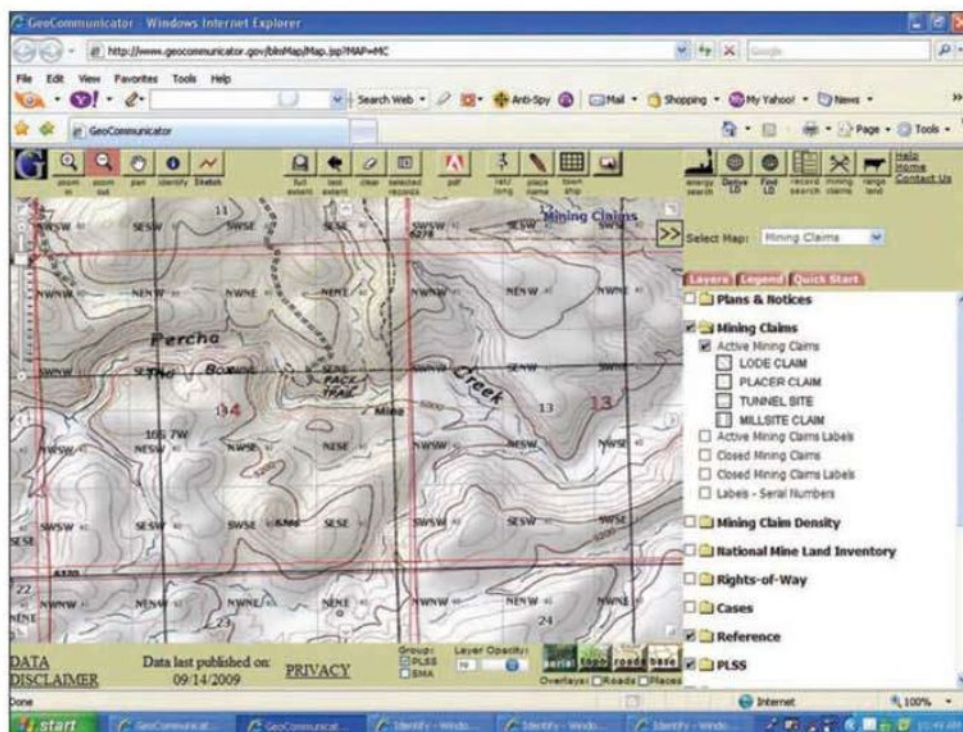

This screen from GeoCommunicator shows active claims around the Percha Box in New Mexico in a gold pattern.

NEW ERA GEMS

Please call us for our
FREE COLOR CATALOG!

**WE TRAVEL TO AFRICA & BRAZIL TO BRING
YOU THE BEST, DIRECT FROM THE SOURCE!**

2010 SHOW SCHEDULE

TUCSON, AZ

Jan. 30 – Feb. 11, 2010

The Pueblo Gem Show

– Room #110

The River Park Inn

(formally the Pueblo Inn)

WE TRAVEL DIRECT TO TANZANIA

We're displaying a wide variety of faceting rough,
cabbing rough, cut gems, mineral specimens
& polished Brazilian quartz objects!

New Era Gems

14923 Rattlesnake Rd., Grass Valley, CA 95945

CALL US TOLL FREE 1-800-752-2057

(530) 272-1334 FAX (530) 272-2985

email: neweragems@hotmail.com

www.neweragems.com

OPTIMA GEM

PO Box 1421, San Luis Obispo, CA 93406

Color Photos of every gem we offer!

CLOSEOUTS!

- 4x2mm Burma RUBIES - 50¢ each
- 3x2mm MT SAPPHIRES - 95¢ each
- 8mm concave lab RUBY - \$9.50 each
- bright 3ct ZINCITE crystals - 50¢ each

FREE monthly newsletter!

800 543-5563

www.optimagem.com



Learn the fun hobby of
**STAINED
GLASS!**

Professional stained glass supplies, tools, books,
kits, patterns, jewels, mosaic and etching supplies,
and things you never knew you needed until now.

Oh, and glass. Lots of glass.

Send \$3 for our catalog and receive free bonus
coupons and "Getting Started in Stained Glass"

Whittemore-Durgin Glass Co.

P.O. Box 305, Rockland MA 02370

Visit our fun store: 825 Market St., Rockland, Mass.
(866)873-0230 www.whittemoredurgin.com

A New Prospecting Tool:

THE BLM GeoCommunicator

from page 35



An area may look unstaked, but checking GeoCommunicator prior to your trip can help keep you from collecting on active lode or placer claims.

I have been routinely using GeoCommunicator when working in areas that involve BLM, USFS, or other federal land. I have found it most useful when I am working in the western United States in areas that have lots of BLM and Forest Service land. GeoCommunicator is not of much value for work in the eastern United States, where little federal land is open for mining claims.

USING GEOCOMMUNICATOR

While GeoCommunicator can do many things, this article is about using it for mining claims and related land use issues only. The BLM has done an excellent job of summarizing the capabilities and instructions for access on the GeoCommunicator Web site in the event that you want to use this tool for other purposes.

To use the GeoCommunicator, point your browser to www.GeoCommunicator.gov, then click on the link "Mining Claim Map". A new window will open and should show a map of the entire United States. To choose your area of interest, pick "Zoom In" from the tool bar across the top. There is also a small scale bar on the lefthand side of the screen. If you have zoomed too far in, you can pull back to locate yourself on the map. To move the map around, simply switch from "Zoom In" to "Pan".

You should very quickly be able to find the area for which you want to evaluate the status of mining claims. The default Mining Claims screen shows "Active Mining Claims", which are Lode, Placer, Tunnel Site, and Mill Site claims. They are distinguished by the hatch pattern in the claim box.

If you want to know more information about a particular claim, you can go to the

tool bar and pick "Identify". This enables access to the LR2000 MC Report (Mining Claim Report) database. You will find a table enabled with links that you can click on to access more detailed information about the claim. This will typically include the claimant, claim name, location (shown by township, range, and section subdivision), location date, recordation date, and the yearly payment of maintenance fees. One thing that becomes immediately apparent is that having multiple claims can become quite expensive with time, especially if you are a small operator.

Identifying active claims is critical. If you are considering prospecting in an area and it is already properly claimed, you cannot remove any minerals from the site without the permission of the claim owner. Being able to identify the claim owner through GeoCommunicator may enable you to contact that person and get permission to access the site if you feel that it warrants additional exploration.

GeoCommunicator also allows you to identify inactive claims by showing which claim records have been closed. GeoCommunicator is very useful in this regard, as a large mining district will often have hundreds of inactive mining claims. In the field, it is sometimes difficult to tell whether a claim is still valid.

The inactive claims are shown as a blue hatched pattern, and if you look at the date of recordation, you can often get a sense of the historic mining economy. When the price of gold goes up, lode and placer claim activity typically goes up, and when the price of gold goes down, lode and placer claims often expire and the land is once again open for



LAGUNA LACE AGATE



Available at your favorite supplier of fine cutting rough
More information at www.lagunalace.com

Come see us at the Tucson Gem Show 2010

Tucson Electric Park/Kino Sports Complex | January 30 - February 14, 2010
2500 E. Ajo Way | Tucson, AZ 85713
January 30 - February 13, 10 to 6pm | February 14, 10 to 4pm

Located outside along paved road behind Graves tent.

Featured materials Laguna Lace, Agua Neuva, Mexican Red Hots,
New Cherry Creek Jasper from China, Royal Sahara Jasper from Egypt.

Wholesale only

MP Products, LLC | PO Box 9161 | Kent, WA | 98042 | email: lagunalace@gmail.com

A New Prospecting Tool:

BLM GeoCommunicator

from page 36

claim staking. The recent boom and subsequent collapse in metals prices also resulted in a rush to file claims for many metals, and I have noticed that many of these recently filed claims are now expiring.

I have found that placer claims, which with very few exceptions are for gold, appear to be most abundant. Back in the early 1990s, I did a lot of prospecting with a metal detector in New Mexico gold placer districts, and rarely did I ever see any claim notices in the field. If you check these same areas with GeoCommunicator, however, you will find that most of the well-known placer fields, at least the ones that I know of in New Mexico, are currently under claim. I also know from personal experience how difficult it is to find placer gold in the field,

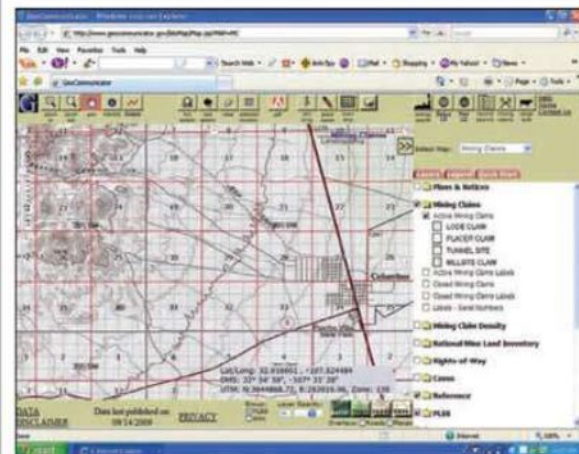

This screen shows no active claims in this area west of Columbus, New Mexico.

especially when there is no water for panning, and it must be extremely expensive for small operators to maintain these claims. I suspect that once the price of gold goes back down, which is always does, some of these claims will become available again. If you are watching an active claim block, GeoCommunicator gives you an excellent way to check on claim status throughout the year. If the claimant misses paying the fees and a claim becomes closed, it may be available for restaking.

As a mineral collector, I have found GeoCommunicator to be extremely useful. Many of the fluorite, pegmatite, and mineral specimen districts in which I collect have had many claims staked in them, but through GeoCommunicator I can confirm whether they have been closed and are open for collecting. If I find that a site has an active claim, I am able to avoid that area while collecting. I have found that many popular specimen collecting sites are under claim, so you have to be extremely careful to make certain that you do not intrude on a claim.

Due to the expense of staking and maintaining mining claims, I am not actively

Something SO SIMPLE

shouldn't have to be so expensive!

DopStation™

Features:

- Lighted On/Off Switch
- Ceramic Element Heats Quickly
- Warming Bezel for Better Dopping
- Tool Caddy for dops, and other tools

Item# 450110
DopStation™
MSRP: \$32.95

www.inlandlapidary.com

Dealer Inquiries Invited - 230V Available

Visit us in Tucson
at the InnSuites,
room 324

C L O S E O U T

Fine quality gems at liquidation prices!



FACETED & CABOCHON STONES

CEYLON SAPPHIRE, pastel color, blue, pink, green, 2.50 - 2.75 mm princess	3 pc for \$8.00
BLACK STAR SAPPHIRE, cabochon, fine quality, 8x6 mm oval	\$10.50 each
RUBY, Burma, nice color, 2 mm round	5 pc for \$3.25
TANZANITE, blue, AAA, beautiful cut, 3 mm round brilliant	\$18.00 each
SPINEL, Burma, pink, fine cut, 2 mm round	\$ 2.99 each
BLACK SPINEL (black diamond subst.), fine cut, 2 mm round brilliant	\$0.90 each
SILVER TOPAZ, fine cut, 3 mm round brilliant cut, \$0.75 each, 6 mm round	\$3.60 each
SKY BLUE TOPAZ, fine cut, 3 mm round	\$2.00 each
AMETHYST, dark purple, fine cut, 3 mm, round brilliant cut	\$1.25
CITRINE, gold color, fine cut, 6x3 mm marquise	\$1.99 each
GARNET, red, fine cut, 4 mm round	10 pcs for \$7.50
RHODOLITE GARNET, fine cut..... 4 mm round, trillion \$2.50 each	2.5 mm, round \$.80 each
HESSONITE, 3 mm, round brilliant, root beer color,	\$1.75 each
MEXICAN OPAL, fine cut..... orange, 4x6 mm oval \$3.00 each	yellow, 7x5 mm oval, \$2.99
ZIRCON, Cambodia, with a hint of blue beautiful 2 mm round	\$0.50 each
HELENITE, volcano stone, fine cut 5 mm rounds, red, blue, or green	\$3.00 each
TOURMALINE, cabochon, pink..... round, 4 mm \$3.50 each.....round, 5 mm	\$5.40 each

Visit us at

www.midlandgems.com

BURMA JADE & MAW SIT SIT

ROUGH Huge selection!

Gemstone Carvings

FACETING AND CARVING SERVICES

VISA, MC, AMEX, CHECKS, Money Orders are welcome.

S&H \$5.00 USA, 8.25% sale tax for CA residents without valid sale permit, free price list available.

VR GEM CUTTERS

PO Box 1263, Thousand Oaks, CA 91358 1-888-777-3148 Email: vrgems@msn.com



EBERSOLE'S

YOUR LAPIDARY & JEWELRY SUPPLY SHOP

Over Stock ED SALE

Jan./Feb.
2010

PRICES IN THIS AD
GOOD FOR 90 DAYS

Unikite #952

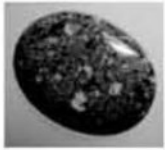

Sizes
30 x 40 mm
13 x 18 mm
10 x 12 mm
8 x 10 mm
6 x 8 mm

Rhodonite #792

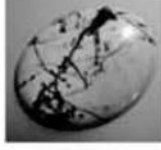

Sizes
13 x 18 mm
10 x 12mm
8 x 10 mm
6 x 8 mm

Rose Quartz #795

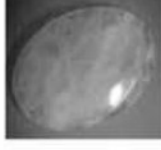

Sizes
30 x 40 mm
13 x 18 mm
10 x 14 mm
10 x 12 mm
8 x 10 mm
6 x 8 mm

Rainbow Fluorite #380



Sizes
13 x 18mm
10 x 12mm
8 x 10mm

White Quartz #762



Sizes
30 x 40 mm
22 x 30 mm
13 x 18 mm
10 x 12 mm
8 x 10 mm
6 x 8 mm

**Sale Price for Cabochons
(Lapis NOT included)**

30 x 40 mm	\$2.25 Each
22 x 30 mm	\$1.75 Each
18 x 25 mm	\$1.25 Each
13 x 18 mm	\$.63 Each
12 x 16 mm	\$.50 Each
10 x 14 mm	\$.40 Each
10 x 12 mm	\$.35 Each
8 x 10 mm	\$.30 Each
6 x 8 mm	\$.25 Each
5 x 7 mm	\$.23 Each

Green Aventurine #175

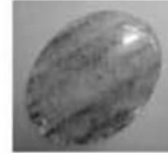

Sizes
30 x 40 mm
13 x 18 mm
8 x 10 mm
6 x 8 mm
5 x 7 mm

Check out our eBay site
<http://myworld.ebay.com/ebersolerocks/>

Add Shipping
And Handling of
\$6.00 per Order

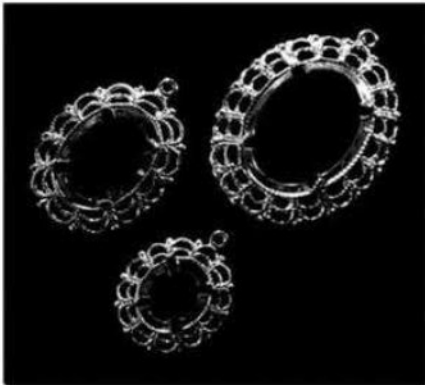

#60 Fancy Lace Edge Mountings
SILVER OR GOLD COLOR

Sale Price on 1 - 11 Items

18 x 25 mm	\$1.04 Each
13 x 18 mm	\$.80 Each
10 x 12 mm	\$.72 Each
8 x 10 mm	\$.64 Each

Sale Price for One Dozen

18 x 25 mm	\$7.90 doz.
13 x 18 mm	\$6.00 doz.
10 x 12 mm	\$5.40 doz.
8 x 10 mm	\$4.80 doz.

Lapis #595



Sizes	Sale Prices
30 x 40 mm	\$17.50 Each
22 x 30 mm	\$14.00 Each
18 x 25 mm	\$11.50 Each
13 x 18 mm	\$ 6.50 Each
12 x 16 mm	\$ 4.75 Each
10 x 14 mm	\$ 3.25 Each
10 x 12 mm	\$ 2.38 Each
8 x 10 mm	\$ 1.63 Each
7 x 9 mm	\$ 1.25 Each
6 x 8 mm	\$.88 Each
5 x 7 mm	\$.75 Each
4 x 6 mm	\$.50 Each
4 mm Dia.	\$.50 Each
6 mm Dia.	\$.75 Each
8 mm Dia.	\$ 1.25 Each
10mm Dia.	\$ 2.00 Each

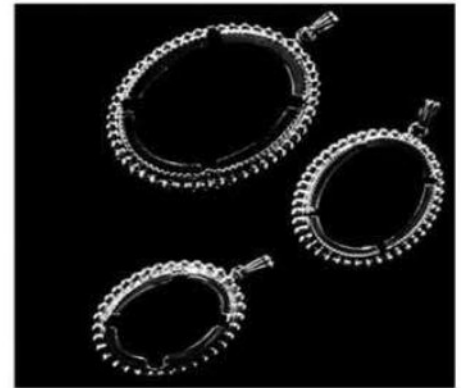

#20 Beaded Edge Mountings
SILVER OR GOLD COLOR

Sale Price on 1 - 11 Items

30 x 40 mm	\$2.08 Each
18 x 25 mm	\$1.44 Each
13 x 18 mm	\$1.28 Each

Sale Price for One Dozen

30 x 40 mm	\$15.60 doz.
18 x 25mm	\$10.80 doz.
13 x 18 mm	\$ 9.60 doz.

These are just a few items from our catalog and new items. PLEASE ADD \$6.00 TO ALL ORDERS FROM THIS AD UNLESS OTHERWISE STATED TO HELP COVER COST OF PACKAGING AND POSTAGE. Our catalog of over 100 pages is free with a \$10.00 or more order, please state on order. If you wish to receive our catalog only, send \$5.00 and we will give you \$7.50 credit on your first order of \$27.50 or more. Please allow approximately 3 weeks if you order only catalog. Please give complete street address. Add extra postage going outside continental U.S.A., Thanks.

ebersolelapidary.com
EBERSOLE

PHONE: 316-945-4771 FAX: 316-945-4773
E-Mail: ebersolerocks@sbcglobal.net

LAPIDARY SUPPLY, INC.
5830 WeSt HeNDRYx, DePt . RG
WICHIt A, KANSAS 67209

GemMaster[™] For Christmas...

BRILLIANT!



10% Savings On All Accessories

SALE ENDS 12/20/09

Fac-Ette
MANUFACTURING, INC.

www.fac-ette.com



9545 Ploof Road
Leland, NC 28451

910.371.3776 • 800.336.9248



LAPIDARY EQUIPMENT JS GEMS



Our slogan is "Quality lapidary equipment at discount prices"

***Ameritool *Covington Engineering *Gryphon**

***Barranca *Diamond Pacific *and More!!**

(909) 519-1545

e-mail: jsgems@dslextreme.com

www.jsgemslapidary.com

A New Prospecting Tool:

THE BLM GeoCommunicator

from page 38

staking claims, so I use GeoCommunicator as a screening tool for collecting only. If you do decide to start staking claims, however, remember that GeoCommunicator is not a substitute for proper due diligence. It is possible that a claim may have been filed on a site, but not yet entered into the system, or that entered claims have not yet been updated in the database (this is done about once a week). As part of your evaluation of claim status and land title, you will almost certainly have to review the records at the county courthouse and state BLM office to confirm that no one has an active claim on or title to the land. It is also possible for a claimstake to be improperly recorded by the BLM or another agency. The BLM typically does not intervene between disputes among claim owners, and if you are paying your claim maintenance fees, it are not going to check whether there is already another claim on the site. It is up to the claim owner to do due diligence.

In addition, patented mining claims may not show up in the database. Patented claims are private lands that were acquired through a process that allowed mining claims to become owned by the claim owner. You can often spot patented claims on USFS and BLM maps, as they tend to be irregularly shaped white parcels (private land) in areas of green (USFS) or yellow (BLM) land. Although current law allows you to stake a mining claim on federal lands that are open to mineral entry, in 1994 Congress declared a moratorium on applying for a mineral patent to a properly located and recorded mining claim that has not been rescinded. While this moratorium is in effect, the BLM cannot accept mineral patent applications. Since a patented claim is now private land and no longer technically a claim, it will not show up in GeoCommunicator as an active claim on federal lands.

GeoCommunicator is a great tool for anyone involved in looking for minerals on public lands. Access requires no special hardware or software, and it puts the small independent prospector on an equal footing with the largest companies in their ability to quickly access the status of claims in a mining district. While it is a good screening tool, it is not a substitute for proper due diligence, and if you decide to start staking claims, be ready for an education in the school of hard knocks. Mining is a tough and expensive business, and investing in the development of mining claims is risky and full of uncertainty. GeoCommunicator can reduce some of your costs, but it cannot eliminate all of your risks, so be sure to recognize its limitations when using it to plan your next prospecting adventure. ♦



**Tucson
2010**

**The
"Show of Shows"
In Tucson**

Holiday Inn/Holidome

February 4 thru February 12, 2010

**~Wholesale Only~
Tax License Required
For Admission**

**Register Online
@ glwshows.com
for your Tucson
Buyer Badges**

**Worldwide Exhibitors
Showing in the**

- **Meeting Rooms** •
- **Pavilions** •
- **Ballroom** •
- **Suites** •

For more information contact

Gem & Lapidary Wholesalers, Inc. • P.O. Box 98 Flora, MS 39071-0098

Phone: (601) 879-8832 • Fax: (601) 879-3282 • E-Mail - info@glwshows.com • www.glwshows.com

The 2010 Tucson Shows

Where to Find Your Favorite *Rock & Gem* Advertisers

1 WESTWARD LOOK RESORT, 245 E. Ina Rd. (www.westwardlook.com)

The Collector's Edge, Suite #242, February 5-8

Emeralds from the Kagem Mine in Zambia; Thomas Range, Utah, sherry-colored topaz crystal clusters and matrix specimens; Pike's Peak blue-green amazonite and smoky quartz; Moroccan native silver and silver after dyscrasite; Sweet Home Mine rhodochrosite.

Pala International, February 5-8

Exquisite collector specimens including classics, new arrivals, gem crystals, and featuring Will Larson's Japanese collection.

Wilensky Fine Minerals, February 5-8

2 THE GRANT INN, 1365 W. Grant Rd.

Gem and Lapidary Wholesalers, Inc., January 30 - February 12
Saturday through Thursday 10 a.m. - 6 p.m.; Friday 10 a.m. - 3 p.m.

3 MINERAL & FOSSIL MARKETPLACE, 1333 N. Oracle Rd.

Martin Zinn Expositions, February 1-10

Free treasure hunt! Win great prizes for visiting great shows. Pre-register at www.mzexpos.com, or during the show at the Hotel Tucson City Center.

The Foothills Boxes, Space # 14, January 27 - February 14

4 EXECUTIVE INN MINERAL & FOSSIL SHOW, 333 W. Drachman St.

Lasco Diamond Products, Inc., January 30 - February 14

Free gem carving demonstrations and how to's, including internal quartz carving. Watch and ask questions about stone carving, jewelry making, etc.

5 HOTEL TUCSON CITY CENTER, 475 N. Granada Ave.

Martin Zinn Expositions, February 1-10

Free treasure hunt! Win great prizes for visiting great shows. Pre-register at www.mzexpos.com, or during the show at the Hotel Tucson City Center.

John E. Garsow, Room #235, January 30 - February 13
Quality faceting rough.

Mineral of the Month Club, Copper Ballroom, January 30 - February 13

6 RAMADA LIMITED, 665 N. Freeway (www.tucsonramadalimited.com)

Martin Zinn Expositions, February 1-10

Free treasure hunt! Win great prizes for visiting great shows. Pre-register at www.mzexpos.com, or during the show at the Hotel Tucson City Center.

Blaine Reed - Meteorites, Room 134, January 30 - February 13

Meteorites of all kinds (including moon rock and Mars rocks) and tektites (including Moldavites) for sale, and the occasional mineral or fossil specimen.

7 TUCSON CONVENTION CENTER, 260 S. Church Ave.

Pala International, AGTA GemFair, February 2-7

Pala International, TGMS Main Show, February 11-14

Mix of mineral specimens from the large and unusual to miniature classics.

Dixie Euhedrals, TGMS Main Show, February 11-14

Francisco Sotomayor, Sculptor, TGMS Main Show, February 10-14

Francisco's 10,000-pound life-size marble sculpture the "American Woman" is sponsored to be a guest exhibit.

8 TUCSON SHOWPLACE, 1530 S. Freeway (www.tucsonshowplace.net)

The Gem Shop Inc., Space A-1, January 29 - February 14, 9 a.m. - 6:30 p.m.

9 QUALITY INN-BENSON HWY., 1025 E. Benson Hwy.

Martin Zinn Expositions, February 1-10

Free treasure hunt! Win great prizes for visiting great shows. Pre-register at www.mzexpos.com, or during the show at the Hotel Tucson City Center.

10 TUCSON ELECTRIC PARK GEM & MINERAL SHOW, Kino Sports Complex, 2500 E. Ajo Way

Barranca Diamond, Tent 20, January 31 - February 1

Fac-Ette Manufacturing, Booth #P-68, January 20 - February 14

Gem Center USA Inc., Tent #12, January 30 - February 14

Quality Mexican geodes, cabochons, rough banded agates, jaspers and minerals.

JS Gems/Barranca Diamond, February 8-13



Special Sale Event, open to everyone (wholesale and retail). Unbelievably low prices on Barranca Diamond equipment, blades, and other products.

Kent's Tools, Pavilion Tent Space #1, January 30 - February 14
Largest inventory and best prices on jewelry and lapidary tools, equipment and accessories at the Tucson Show.

MP Products, January 26 - February 14
The first public showing of a gorgeous, new gem rough discovery from China. Cherry Creek jasper has bright primary colors of red and yellow, as well as other

colors, and exotic patterns. Viewing and sales will begin on January 26 in the MP Products outside booth.

11 THE GEM MALL, 4475 S. Country Club Rd.
Gem and Lapidary Wholesalers, Inc., January 30 - February 12
Saturday through Thursday, 10 a.m. - 6 p.m.; Friday 10 a.m. - 3 p.m.

12 HOLIDAY INN PALO VERDE/HOLIDOME, 4550 S. Palo Verde Rd.
Gem and Lapidary Wholesalers, Inc., February 4-12, Thursday through Thursday, 10 a.m. - 6 p.m.; Friday 10 a.m. - 3 p.m.



On the Rocks Gems, Jewelry & More

5709 N. Clark St. Chicago, IL 60660

(773) 649-0111

visit us online:
www.ontherocksinc.com

- Mineral & Fossil specimen
- Wire wrapped creations by Gonzo
- Handmade Jewelry
- Beads & Jewelry supplies
- Cut precious & semiprecious gems
- Local Artwork
- Books

"May the Quartz be with you!"

ROCK PEDDLER DISCOUNT LAPIDARY EQUIPMENT & SUPPLIES



- Facetron • Crystalite
- Covington • Diamond Pacific
- Graves • Raytech
- Inland • Omni

800- 416-4348

P.O. Box 5964, Marlborough, MA 01752

E-mail: rp@rockpeddler.com

Website www.rockpeddler.com

Facet Rough: www.bestrough.com



Welcome

Treasure Chest

- Lapidary Machinery & Supplies
- Quality Freeform Cabochons
- At affordable prices



Treasure Chest

1942 S. Glenstone Ave., Plaza Shopping
Center, Springfield, MO 65804

417-823-3800

www.treasurechestspringfield.com

ROCK SCIENCE

by Steve Voynick

Looking Back

For four decades, *Rock & Gem* has documented the sweeping changes that have come to rockhounding and mineral collecting. As one example, consider the price of gold. When this magazine published its first issue in January 1971, the price of gold was fixed at \$35 per troy ounce. Today, as *Rock & Gem* begins its 40th year in print, gold has topped \$1,000 per troy ounce.

When *Rock & Gem* was launched, mainstream interest in the hobby of mineral collecting was just beginning. Backed by higher levels of education and disposable income, countless individuals were then searching for new educational and recreational outlets. Many found what they were looking for in minerals. Gem and mineral shows, including the now-classic events at Tucson and Denver, were just getting off the ground and had spectacular exhibits that helped to attract a legion of new collectors. Meanwhile, dozens of mineral clubs, many of which remain active today, were just recruiting their first members.

Yet, even then, the hobby of mineral collecting was in transition. In 1970, American mining was a vibrant industry that provided most of our mineral specimens. Many historic mining districts were still active and dozens of smaller mines helped to supply specimens, while their waste dumps provided fine opportunities for field mineral collectors. The industry, however, would soon run into trouble on both the economic and environmental fronts. The federal Clean Air and Clean Water acts of the early 1970s, while doing much to improve environmental quality, compromised the competitiveness of the mining industry by sharply increasing its operating costs. The subsequent diversion of investment capital into the development of foreign, rather than domestic, mines accelerated the emergence of a global metal market.

It didn't take long for the decline of American mining to impact mineral collecting. By 1980, many smaller mines had closed, while dozens of old mining districts once frequented by field collectors had been reclaimed and then forgotten. A growing supply of specimens from places like Mexico, Peru, Bolivia, Morocco and China began replacing American minerals at shows and rock shops.

Rock & Gem's first readers included rockhounds who searched for minerals and fossils on our public lands—and did so with



few restrictions. In 1976, however, changes in federal public-land-use policies imposed mineral-collecting limits, required permits for commercial collecting, and banned the unauthorized collecting of vertebrate fossils.

More change resulted from the emergence of commercial collecting companies, not just in the United States, but around the world. To supply the growing demand for quality specimens, these companies contracted with mine owners for the exclusive right to collect specimens that became available during mining operations. Today, most specimens on the markets are supplied not by independent collectors, but by commercial companies.

Despite these changes, the hobby of mineral collecting has not only survived, but has become bigger and better than ever. Today, specimen markets are booming with a huge supply of fine material from around the world. And although there may be fewer collecting sites today than in the past, field mineral and fossil collecting continues to do very well, thanks to increasingly sophisticated and determined amateur collectors, better research, and the benefits of club membership.

Just as \$35 gold is now a part of the past, \$1,000 gold may also fade into history, perhaps sooner than we think. Like the price of gold, the hobby of mineral collecting will also continue to change, leaving lots to document as *Rock & Gem* looks ahead to its next 40 years. ♦

Steve Voynick is a science writer, mineral collector, former hard rock miner, and the author of books like *Colorado Rockhounding* and *New Mexico Rockhounding*.



JADEITE CARVING DRAGON & PHOENIX



15" WIDE X 9" TALL X 2" THICK
PALE LAVENDER WITH GREEN COLOR
32,000+ CARATS @ \$0.50 / CARAT
\$16,000

BILL EGLESTON

509RG BRENTWOOD RD
MARSHALLTOWN, IA 50158
TEL: 800-798-4579
EMAIL: bill@billegleston.com

Amateur Geologist

*Supplies for the recreational
geologist and rockhound*



Books - 800 titles - most
at 30% off
Estwing rock hammers
and tools
Loupes - BelOMO &
Bausch & Lomb
Geology maps & charts
Educational rock &
mineral collections
Hardness pick sets
Vests with pockets galore
Ultraviolet lights
Rock tumblers
Rockhound stuff for kids
Novelties

Discounted internet prices!!!

www.amateurgeologist.com



JOHN E. GARSOW FOR GEMS & MINERALS

P.O. Box 594, Murrieta, CA 92564
Phone/Fax (951) 698-4833
Cell (818) 800-5644
johngarsow@sysmatrix.net



Come see us at a Gem & Mineral Show near you, or visit us anytime online at

www.JohnGarsow.com

In Tucson at the
Inn Suites
475 N Granada Ave.
Tucson, Az. 85701
Room #235

**Jan. 30th
thru Feb. 13th**

**The Martin Zinn
Expositions Arizona
Mineral &
Fossil Show.**



PICKS & PANS

News and Reviews

DVD REVIEW:

What's Hot in Tucson 2009

Host: Dave Wilber

If you'd like to whet your appetite for the forthcoming 2010 Tucson mineral show season, "What's Hot in Tucson 2009" (BlueCap Productions, 2009) will do the job well. In this third release in the WHIT series, host David Wilber takes viewers behind the scenes at four Tucson venues—the InnSuites Hotel and Suites, Fine Minerals International, the Westward Look Resort, and the Tucson Convention Center. In each location, Wilber interviews well-known dealers from all over the United States, including Rocksaholic LLC, The Collector's Edge, Seibel Minerals, Pala International, and The Arkenstone, plus international dealers such as Fabre Minerals (Spain), Gobin (France), and Crystal Classics (England). Wilber was a mineral collector for many years and has helped others

build world-class collections. He demonstrates knowledge of classic sources and specimens, new mineral discoveries, and specimens from older collections that are on the market for the first time.

Viewers can look forward to a quality experience. As Wilber turns a specimen in his hands, the camera zooms in for a 360-degree view. Videographer Bryan Swoboda manages to get every detail in focus, making a hotel room behave like a well-lit studio. As Wilber and the dealer discuss specimen quality, crystal form, mining history, and everything in between, every word is picked up clearly. The name and origin of each mineral appears on screen. Each dealer's name and contact information is also shown.

At the Westward Look Show, Wilber has a conversation with Gail and Jim Spann, who were invited to display their private collection that year. In two segments in the

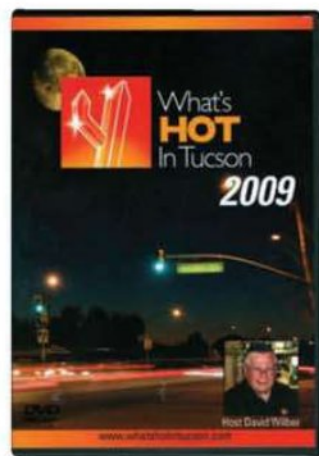

Special Features section, photographer Jeff Scovil shares 10 of the best mineral photographs he has taken at the show and Wilber displays a collection of 13 minerals, each of which he purchased for under \$100.

This 2-disc set contains over four hours of video and sells for \$29.99. Additional footage that did not make it onto the DVD can be viewed free on the BlueCap Productions Web site.

—Lynn Varon

BlueCap Productions, (310) 856-9882; info@bluecapproductions.com; www.bluecapproductions.com

continued on page 48

CAUTION FREE PARKING



GEM MALL

(behind the Holiday Inn/Holidome)

January 30 thru February 12, 2010

Wholesale Only Tax License Required for Admission

FREE Shuttle Service to other G&LW Shows

For More Information Contact:

Gem & Lapidary Wholesalers, Inc. • P.O. Box 98 Flora, MS 39071

Phone 601.879.8832 • Fax 601.879.3282 • E-mail info@glwshows.com • www.glwshows.com

Register Online
@ glwshows.com
for your Tucson
Buyer Badges

AHEAD

Tucson Electric Park

Gem and Mineral Show 2010



*Get
Rocked!*

Kino Sports Complex
2500 E. Ajo Way
(follow Kino Sports Complex signs)

Jan. 30 - Feb. 14, 2010
10am - 6 pm Daily (Closes at 4pm on last day)

Color Aerial Photography
© 2008 Lynn Douglas, Lawyer
7543 2 2700A

Featuring the dealers listed below, and many others:

- Antero Minerals & Jewelry • AZ Gems • Barranca Diamond Products • Blake Brothers • Crystalite
- David's Displays • Diamond Pacific Tools • Driftstone Pueblo • Elk Grove Mining • Enter the Earth •
- Gem Center USA • Graves Co. • Island Connections • Judy's Crystals N Things • Kent's Tools • LeRaphia Vert
- M.K. Diamond Products • Miller's Rock Shop • Morocco To You • Norcross-Madagascar • Orr's Trading •
- Peru Minerals • Rachid & Aziz • Rock Our World • Royal Quality Gems • Su's Creations • Sunwest Silver
- Tex Mex Imports • The Strong Rock • Village Originals • White Rhino Silver

Wholesale/Retail • Lots of Free Parking
Free Shuttle Service To/From Other Shows

TEP Gem Show, Inc.

P.O. Box 2902, Tucson, AZ 85702

Phone: 520.883.6447 • TEPGemShow@cs.com

Opal & Gemstone Jewelry

Cutting * Designing * Setting

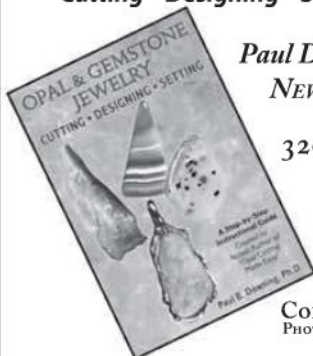

Paul Downing's
NEW BOOK

320 PAGES

COLOR & B&W
PHOTOS & DIAGRAMS

- Cut Your First Gemstone
- Properly Dome an Agate
- Advance to Cutting Opal
- Make Doublets & Triplets
- Design & Assemble Intarsia
- Create Lost Wax Jewelry Designs
- Set the Stones You Have Cut

\$29.95 PLUS \$6.00 S&H

MAJESTIC PRESS, INC.

P O Box 1348, Estes Park CO 80517

Email: majesticpress@aol.com

www.majesticpress.com

Phone 800.468.0324

Picks & Pans *from page 46*

PERIODICAL REVIEW: **Mineralogical Almanac, Vol. 14, Issues 2 and 3**

If you have not subscribed to this excellent series of mineral magazines, you really should. Each issue of *Mineralogical Almanac* features in-depth articles by leading writers, mineralogists and scientists. The periodical's emphasis on Russian minerals reflects its origins in Russia, but its scope goes well beyond that vast mineral-rich country.

Vol. 14, Issue 3, titled "Mineral Observer" (2009) features several Russian museums, some of which I have visited. The information is topical and up to date, and the articles incorporate information on world-wide sources of minerals. Other articles examine the major mineral shows, like Tucson, Arizona, and St. Marie aux Mines in France.

Recent mineral finds, book reviews, and general articles on minerals from around the world round out the offerings in this superbly composed periodical. The full-color photographs are excellent and add to the quality of the publication. This particular issue contains 147 color photos!

Issue 2, titled "Ural Emerald Mines" (2009), is a superb review of the discovery and mining of emeralds from this deposit. While the issue emphasizes Russian emeralds—their history, chemistry and mining—it also offers in-depth information of the other species found in the emerald deposit. These include phenakite and world-famous chrysoberyl, variety alexandrite.

The 104 color photographs are superb and are accompanied by excellent line drawings, which help the reader understand the crystallography of the minerals described. The entire text is summarized superbly by the chapter "The Origin of Gem Crystals", a most fascinating discussion of the processes that create such natural beauty in gem minerals.

A one-year subscription to *Mineralogical Almanac* is \$70. Single copies can also be ordered or found at major shows.

—Bob Jones

Mineralogical Almanac, 4871 Dudley St., Littleton, CO. 80123; minbooks@online.ru; http://webcenter.ru/~minbooks/publish.html



2009 World Rock Tumbling Championship

On the night of Sept. 29, 2009, a distinguished group of four gentlemen gathered to score the stones submitted by the contestants in that year's World Rock Tumbling Championship, sponsored by the Feather River Lapidary & Mineral Society of Oroville, California. Each contestant had received 4 pounds of rough jasper from Stoney Creek in early May and was given until Sept. 15 to do his best to grind and polish it. Each contestant returned at least 1/2 pound of his best material to be judged.

The judging panel consisted of FRLMS member Manuel Garcia; John Wills, owner of Marsha's Minerals; Paradise Gem & Mineral Club member Glen Rollins; and FRLMS Vice President David Cossey, who served as a tie breaker.

The entries were judged on the quality of polish, freedom from pitting, shape, and overall appearance of the stones on the entire batch, as well as the best three stones, for a total possible score of 100 points.

Steve Hart, FRLMS President, and Lisa Ekdahl, Contest Chair, announced the winners at the Oroville Rock & Gem Show on Oct. 4, 2009. First prize (\$250) was awarded to Wayne Snyder of Newark, Ohio; second prize (\$100) to Elaine M. Hammer of Fruit Heights, Utah; and third prize (a Lortone Twin Barrel Rock Tumbler) to Tom Kuzia of Beacon Falls, Connecticut.

Next year's contest has been announced on the FRLMS Web site, www.oroillerocks.com. The tumbling material will be quality Wonderstone from a private mine in the Fallen, Nevada, area and has been named Royal Nevada jasper. For more information, contact Feather River Lapidary and Mineral Society, c/o Lisa Ekdahl, P.O. Box 266, Bangor, CA 95914, (530) 679-0288. ♦

Subscriber Alert!

You may be contacted by unauthorized subscription agents asking you to renew your subscription. These companies are not authorized to represent *Rock & Gem*, nor are they affiliated with us in any way. Please do not give out any personal, payment, or credit card information to these companies. *Rock & Gem* will not accept orders from these companies; if you choose to renew through them, you will likely never receive any issues of *Rock & Gem*. If the status of your subscription is in doubt, call our authorized subscription service at (760) 291-1549 or e-mail RockAndGem@pcspublink.com and request a reply.

FREE 64 PAGE CATALOG

TOP "AAA" Quality, Precision Cut and Polished GEMSTONES

For:

Gem Collectors, Hobbyist Jewelers
Wirewrappers, Retailers
Manufacturing Jewelers

1,000's of different varieties
and sizes



Pioneer Gem Corporation

Dr. Edward J. Nowak, Jr.

PO Box 1513 RG

Auburn, WA 98071-1513

Phone: 253.833.2760

FAX: 253.833.1418

Website: www.pioneergem.com

email: pioneergem@seanet.com

Our 38th YEAR



Steven's Rocks & Gifts FOR ROCK HOUNDS

Mineral Samples Carvings Rough
Rocks Fossils Beads Findings
Covington Engineering Dealer
MK Diamond Blades & Pads

OPEN MON - THURS: 1-5 PM

FRI: 1-6 PM • SAT & SUN: NOON-5 PM

PH-FAX 608-655-1011

134 East Main St., Marshall, WI 53559

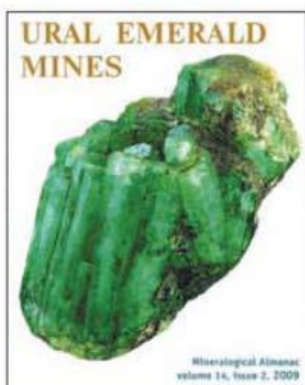

RocknGem.com

World Wide Web Sites

for Rockhound and Lapidary Hobbyists

www.CapistranoMining.com

Home Mining for Rare Benitoite from California, Sapphire from Montana's El dorado Bar and Rock Creek Regions, and Tourmaline from San Diego County, California. Mine Run Gravel and Ore packs for sale and much more. Direct from the mines to you. Also check out our Ebay auctions and feedback, ID capistranomining. Mine your own gem rough and specimens at home. Order Now!

www.kristalle.com

Laguna Beach, California. Specializing in fine mineral and gold specimens for collectors and museums. Booths at major shows around the world.

www.sapphiremining.com

Montana Sapphire Gravel concentrate and jewelry. From Rock Creek Deposit near Philipsburg. Ship up to 4 bags for \$10 shipping. 406-363-6650.

www.katyrockshop.com

Offering exciting rocks, minerals and fossils from all over the world. We have everything from small miniature to large cabinet specimens. You will find items for all collectors priced to fit your budget.

www.fisher-reealty.com/candc.html

C & C Minerals offers a variety of gift items and specimens. Many are unique. The offerings change regularly, so check often. We ship nationwide. Free gift with each order. (386)253-5884. e-mail: candc@fisher-reealty.com

www.oakrocks.net

We sell rough rock, decorator polished pieces, eggs, spheres, animal carvings, cabochons, mineral specimens, slabs, fossils, jewelry, beads & more! For designer cabochons visit www.barlowsgems.net

www.MarshallLapidaryEngineering.com

"Gemstone Flat Lapping, Mechanized," an unusual new book on lapidary, shows you how to cast, grind and polish multiple flat items integrated into a single casting. Semi-automated flat lap and vibraplaps process the casting through coarse grit, fine grit, and polish stages. e-mail: aggateer@aol.com

www.beautifulagates.com

Bringing you the best in the world of exceptional agates. We specialize in Mexican, Lake Superior and other world-wide agates. We also carry many fine books about agates. e-mail: agatemike@msn.com

www.rocksandminerals.org

Published since 1926. The Magazine for everyone interested in Minerals, Rocks and Fossils. e-mail: subscribe@heldref.org

www.CrystalGrove.com

Herkimer "Diamond" Gem Mining, camping on site, cabins, RV & tent sites. Rock Shop. Nature and mining — it's all here in the foothills of the Adirondacks in upstate NY.

www.lototumbler.com

Manufacturer of Lot-o-Tumbler. Vibratory tumblers available in twin or single barrel, 110 or 220. Manufactured 50+ years. Grits and supplies. Belt buckle findings. (507) 451-2254. email: molly1385Lts@yahoo.com

www.themineralgallery.com

Offering a large assortment of quality mineral specimens in varying sizes. We also feature a bi-weekly rock and gem auction. Cabinet size specimens our specialty. e-mail: kward@themineralgallery.com

www.richardsonrockranch.com

Home of the famous Friday Agate Beds. Dig for Thundereggs. Visit our vast rock shop. See rough rock from the world over, lapidary equipment including our own high speed sander, buffer and world's best crafted spheres. (800) 433-2680. 7 a.m. - 5 p.m. PCT.

www.thegemshop.com

Online since 1998, offering rough rock, designer cabochons, fine agate and jasper specimens, beads, publications, lapidary equipment, monthly specials. Mining reports, rock location information and galleries. Order securely online, MC/Visa/PayPal, Toll Free (866) 377-4666. e-mail: mail@thegemshop.com

www.mineralman.net

Large selection of worldwide mineral specimens from thumbnail to cabinet at affordable prices. Fluorescent minerals, "WAY TOO COOL" Ultraviolet lamps, beginner mineral collections, decorative mineral carvings, fossils, custom jewelry, antique documents and other collectibles. Secure online ordering with Paypal or major credit card. Free shipping on mineral orders over \$150.00 in the USA.

www.deepakgems.com

Order online from 30,000 faceted gemstones, carved, cabochons, necklaces individually listed with shapes, sizes, weights, prices. Another 10,000 listed for US\$0.95 each. Jewellers tools, rough gemstones, jewellery available. Credit cards accepted. Free gemstone with catalog. e-mail: deeprok@vsnl.com

www.stuartsminerals.com

Outstanding minerals from around the world. Priced to fit any budget. Also, hard to find specimens from closed mines and collecting sites in upstate New York. Fast shipping.

www.naturesoutback.com

Offering rough agates and jaspers from around the world, books, designer cabochons, slabs, wire wrapped pendants and more. New items are added monthly. Major credit cards, money orders, checks and Paypal accepted. email: jeyewal@aol.com

www.rockawayopals.com

Buy Exquisite Black Opal Gems. Prime selection of cut solid opals from Lightning Ridge, Coober Pedy, Queensland, Mexico & Ethiopia. Unique and custom opal jewelry. e-mail: Scott@rockawayopals.com.

www.gia.edu

Learn from the World's Foremost Authority in Gemology™ online! Find out about the Gemological Institute of America's courses and programs, browse and shop for gemology instruments and books. Stay up-to-date on diamond and gemstone news and research.

www.dragonsayeauctions.com

Accepting registration for sellers and buyers NOW. A website dedicated strictly to handcrafted jewelry, lapidary, gems, fossils, rough, slabs, periodicals. Call (410) 437-9695 for more info or view the site for all the details!

www.azTimelessTreasures.com

Collector items from the USA, fossils, finished or rough lapidary material and equipment, brilliant fluorescents and petrified wood slabs at bargain pricing. New items added regularly. Call (928) 775-9595. Ask about Free U.S. Shipping, our catalog and 50% off coupons.

www.geologicalwonders.com

Rock, Mineral, and Gift Shop. Specializing in specimens, crystals, slabs, rough, gifts, and much more. Visit our website and online store with a secured shopping cart. You'll be glad you did. WEBSITE UPDATED, new arrivals! e-mail: contact@geologicalwonders.com

www.wrightsrockshop.com

Minerals, rare minerals, fossils, cutting rough, lapidary and rockhounding equipment, metaphysical minerals, supplies, wholesale and retail, tourmaline, fluorite, quartz, calcite. Over 750 mineral specimens photographed on-line, with over 750,000 mineral specimens in stock.

www.BandLMinerals.com

Large selection of minerals from around the world for all collectors, from the beginner to the advanced. New items added weekly. Major credit cards, Paypal, M.O. and personal checks accepted. e-mail: bob@bandlminerals.com

www.lehighmineralauktion.com

Weekly auction of 50 specimens with an assortment of quality but affordable worldwide minerals. Don't miss the bargain prices. e-mail: jim@lehighminerals.com

www.calstategemmine.com

The Benitoite Gem Mine is offering you a chance to come screen and black light for Benitoite, the California State Gemstone. One of the rarest and most valuable gemstones in the world. Find Neptunite, Djurleite, Joaquinite, and Benitoite. (559)-935-5909.

www.superagates.com

Offering exceptional agate specimens including Botswana, Laguna, Fairburn Condor, Argentine agates, Dryhead, Crazy Lace and others. We also offer a wide variety of rough cutting nodules and fine tumbling rough at reasonable prices. (402) 992-2935. e-mail: sales@superagates.com

www.phoenixorion.com

100's of metaphysical and gem stone collectibles at rock bottom prices! Crystal and Feng Shui gifts, gem spheres, eggs, hearts, carvings & more. Free shipping and 2 gift wraps w/\$50.00 order! Easy ordering w/same day shipping, online or toll free (866) 720-4174.

www.minertown.com

Worldwide mineral specimens, quartz and gem crystals featuring U.S., Africa, Pakistan and Minas Gerais, Brazil. Cut and polished stone eggs, spheres, bookends, tumbled stones and carvings. Cutting rock and fossils. Gemstones and jewelry produced and serviced by an in-house jeweler. Individual photographs and detailed descriptions. Secure online shopping cart and credit card form.

www.robsrockshop.com

Supplier of Nova Scotia Gemstones. Rough and finished products of crystal, agates and jaspers. Blocks, slabs, jewelry and precut tumbled stones. email: robsrocks@eastlink.ca

RocknGem.com for as little as \$35 per insertion. Contact ads4miller@jmillermmedia.com
Phone: (805) 644-3824 x127; Fax: (805) 644-3875; Rock & Gem, 290 Maple Court, Suite 232, Ventura, CA 93003

ROCK & GEM Kids

Serpentine

$Mg_3Si_2O_5(OH)_4$

Magnesium [iron] silicate hydroxide

Serpentine is a "sheet silicate" combining magnesium (Mg) and silica (Si_2O_5) in a rock with a slick, platy surface. Serpentine shimmers like scales on a serpent, which is how it got its name. Usually, a small amount of iron (Fe) substitutes for some of the magnesium. When this happens, instead of forming crystals, it occurs in masses that are green to green-black and have a greasy, waxy luster. Serpentine is often found with jade. While collectors may confuse the two, they can be distinguished by hardness: serpentine is soft (Mohs 3 to 5) and can easily be scratched with a nail (Mohs 5.5), whereas a nail slides right off jade (Mohs 6.5 to 7).

Serpentine has several polymorphs. (Polymorphs have the same chemical formula, but different crystalline structures.) Chrysotile is fibrous and is sometimes called "asbestos serpentine". Antigorite is a compact variety described as "corrugated" serpentine. Finally,



JIM BRACE-THOMPSON PHOTO

While most serpentine forms in platy masses (left), one variety called chrysotile, or "asbestos serpentine" (right), forms in fibrous bundles.

lizardite (named after England's Lizard peninsula, where it was found) is fine-grained and platy.

Serpentine is a metamorphic rock. It forms along subduction zones, where basaltic rock from the ocean crust piles against continental rock and is subjected to heat and pressure. These marine rocks often contain magnesium silicates like olivine, pyroxene and peridotite, and hydrothermal (hot fluid) alteration produces serpentine. Few plants are able to grow in soil derived from serpentine.

Serpentine has been designated California's state rock because it is so commonly present in the Coast Ranges and the Sierra Nevada mountain range.

Highly compact serpentine can be crafted into lapidary works, and large boulders of the material make nice decorative stones. In the past, asbestos serpentine was used for heat-resistant clothing and equipment (like brake linings) or for asbestos cement, but the health hazards of asbestos put an end to its use.

—Jim Brace-Thompson

Arizona's State Rockhound Symbols

Arizona designated turquoise its state gemstone in 1974. The colorful mineral is found in arid regions where copper is present. The United States is the world's largest producer, and some of the finest comes the Kingman Mine and the Sleeping Beauty Mine in Arizona. Turquoise is opaque, with a waxy luster, and its color ranges from yellow-green to bright blue, as typified by the variety called "Bisbee Blue." Native Americans have crafted turquoise beads, carvings and mosaics since 200 B.C., and the Navajos of Arizona are famed for silver-and-turquoise jewelry, which they've produced since the 1860s.



JIM BRACE-THOMPSON PHOTO

A piece of fire agate, surrounded by blue turquoise, sits atop colorful *Araucarioxylon arizonicum* petrified wood from Arizona.

The petrified wood *Araucarioxylon arizonicum* became Arizona's state fossil in 1988. Within the Petrified Forest National Park, on the eastern side of the state, petrified logs litter the ground. They began as conifers that grew 150 to 200 feet tall. The felled trees were transported by rivers and streams and buried beneath sand, clay and ash in a lowland basin. Over thousands of years, the wood was replaced by silica derived from volcanic ash. Minerals such as iron mixed with the silica, giving it color. Although the material is frequently red, it can be streaked every color in the rainbow. Collecting became so popular that the "forest" became endangered. It was protected as a National Monument (1906), then as a National Park (1962). It's estimated that 3.5 pounds per vehicle leaves the park illegally every day, even though Arizona petrified wood is readily available from

nearby private ranches and rock shops.

Arizona also has an "unofficial" state mineral: fire agate. This is cryptocrystalline (individual crystals cannot be discerned) quartz laid down in botryoidal (bubble-like) bands. Some layers contain inclusions of the minerals goethite or limonite. If ground just right, these layers produce iridescent "fire", with flashes of red, orange, green, or highly prized blue. Lapidaries must treat fire agate with care; it's all too easy to grind right through that iridescence!

—Jim Brace-Thompson

Which One Is Different?

Circle the Herkimer quartz cluster that is different from the other two. This gemmy quartz from New York is normally colorless and water clear.

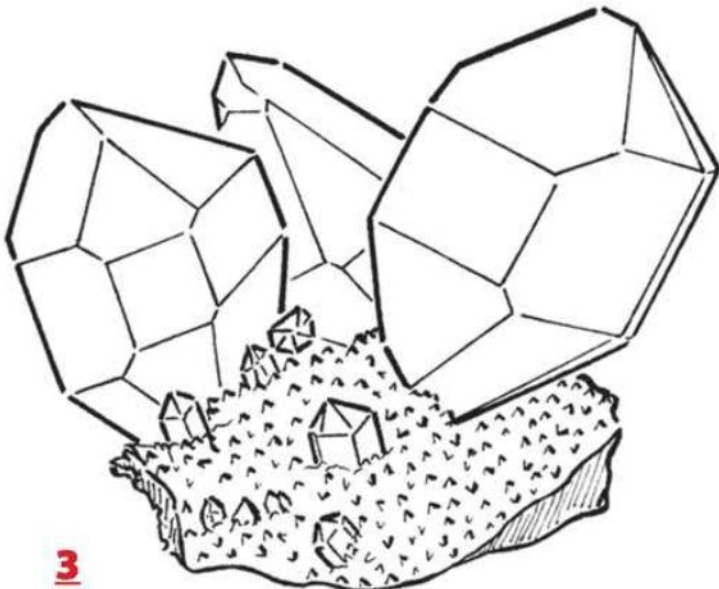
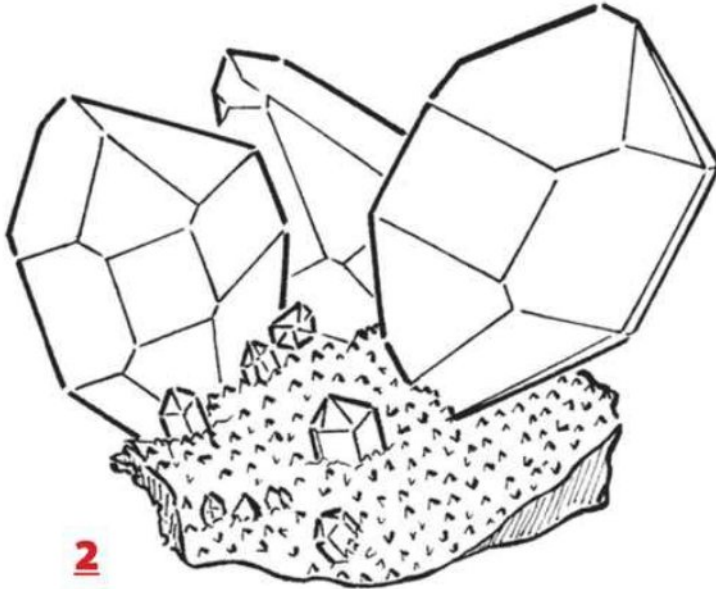
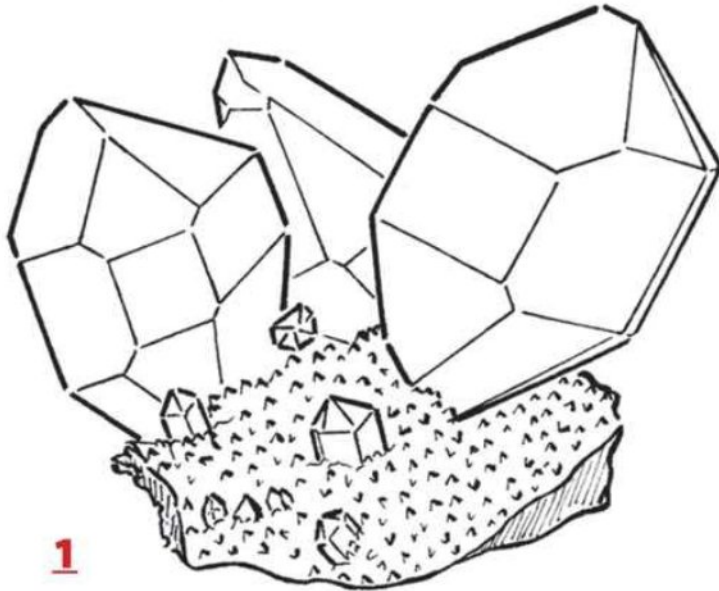

DARRYL POWELL IMAGES

Take the Quiz, Win a Prize!

The Quiz is open to U.S. residents 17 and younger. All the questions can be answered by carefully reading *Rock & Gem Kids*. Mail your answers to **January Quiz, Rock & Gem magazine, P.O. Box 6925, Ventura, CA 93006-9899**. Five winners will be drawn from the valid entries received by **Jan. 31, 2010**. Valid entries must include the correct answers, the entrant's name, age and address, and the signature of a parent or guardian. This month's prize is a 14-inch steel Estwing gold pan donated by Eloxite Corp. (www.eloxite.com; see ad page 77).



1. Serpentine combines the minerals _____ and _____ in a slick-surfaced rock.
2. Jade and serpentine can be distinguished by what property?
3. _____, _____ and _____ are polymorphs of serpentine.
4. Turquoise is found in _____ regions where _____ is present.
5. Inclusions of _____ or _____ give fire agate its iridescence.

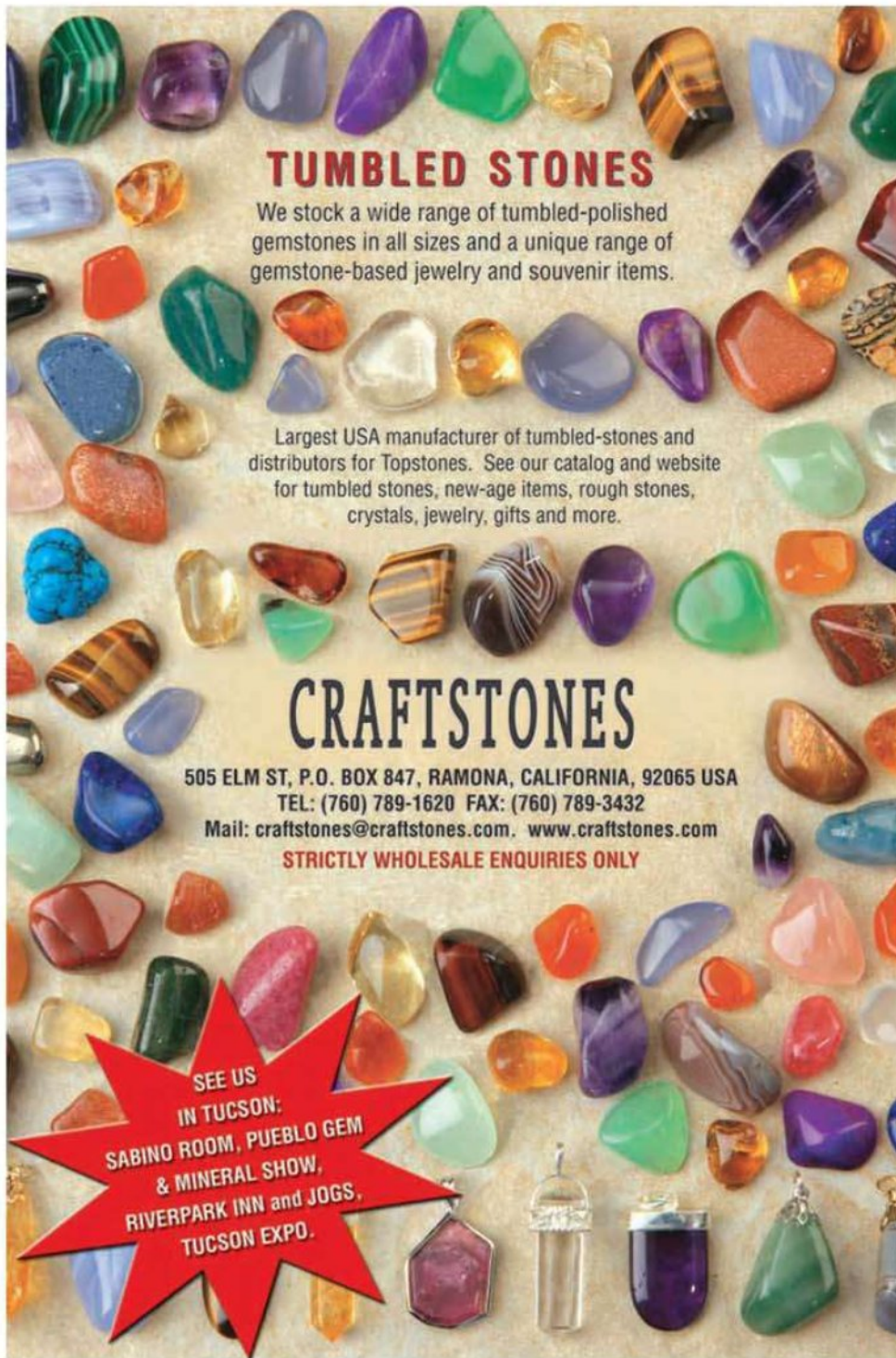

TUMBLLED STONES

We stock a wide range of tumbled-polished gemstones in all sizes and a unique range of gemstone-based jewelry and souvenir items.

Largest USA manufacturer of tumbled-stones and distributors for Topstones. See our catalog and website for tumbled stones, new-age items, rough stones, crystals, jewelry, gifts and more.

CRAFTSTONES

505 ELM ST, P.O. BOX 847, RAMONA, CALIFORNIA, 92065 USA

TEL: (760) 789-1620 FAX: (760) 789-3432

Mail: craftstones@craftstones.com. www.craftstones.com

STRICTLY WHOLESALE ENQUIRIES ONLY

SEE US
IN TUCSON:
SABINO ROOM, PUEBLO GEM
& MINERAL SHOW,
RIVERPARK INN and JOGS,
TUCSON EXPO.

Show Dates from page 20

Ave., 4th floor; admission \$6 (includes flower show); Sat. 10-5, Sun. 10-5; more than 20 mineral and fossil dealers, guided museum tours, mineral and fossil identification; contact Michael Hawkins, (518) 486 2011; e-mail: mhawkins@mail.nysed.gov

20-21—PLAINVIEW, TEXAS: 48th annual show; Hi Plains Gem & Mineral Society; Ollie Liner Center, south I-27; Sat. 10-6, Sun. 10-5; adults \$2, students \$1; dealers, demonstrators, grand prizes, silent auction, kids' wheel; contact Mildred Matlock, 701 Zephyr, Plainview, TX 79072, (806) 293-3476; e-mail: jmmatlock@suddenlink.net

26-27—NORTHRIDGE, CALIFORNIA: Show, "GEMBoree"; Del Air Rockhounds Club; United Methodist Church, 9650 Reseda Blvd.; Fri. 3-9:30, Sat. 10-5; free admission, children under 16 must be accompanied by an adult; gems, jewelry, beads, Girl and Boy Scout merit badges; contact Julia Marin, 18220 Marilla St., Northridge, CA 91325, (818) 886-7190; e-mail: jomarin@dslextreme.com; Web site: <http://delairrockhounds.blogspot.com>

26-28—COSTA MESA, CALIFORNIA: Show, "Gem Faire"; Gem Faire Inc.; OC Fair & Event Center/Bldg. 10, 88 Fair Dr.; Fri. 12-7, Sat. 10-6, Sun. 10-5; \$5 weekend pass; contact Yooy Nelson, (503) 252-8300; e-mail: info@gemfaire.com; Web site: www.gemfaire.com

26-28—MELBOURNE, FLORIDA: Show; Frank Cox Productions; Melbourne Auditorium, 625 E. Hibiscus Blvd.; Fri. 10-5, Sat. 10-5, Sun. 10-5; gems, jewelry, beads; contact Frank Cox Productions, 755 S. Palm Ave. #203, Sarasota, FL 34236, (841) 954-0202; e-mail: frankcox@comcast.net; Web site: www.frankcoxproductions.com

27-28—BOISE, IDAHO: Annual show; Idaho Gem Club; Expo Idaho, 5610 Glenwood; Sat. 10-7, Sun. 10-5; contact Charlie Smith, (208) 628-4002

27-28—EVERETT, WASHINGTON: 57th annual show; Everett Rock & Gem Club; Washington National Guard Armory, 2730 Oakes Ave.; Sat. 10-6, Sun. 10-5; contact Fritz Mack, P.O. Box 1615, Everett, WA 98206, (425) 232-0809

27-28—JACKSON, MISSISSIPPI: 51st annual show; Mississippi Gem & Mineral Society; Mississippi State Fair Grounds/Trade Mart Bldg., 1207 Mississippi St.; Sat. 9-6, Sun. 10-5; adults \$5, students \$3; free demonstrations, door prizes, educational and hands-on booths, 24 dealers; contact Keith Peacock, 114 Quail Ridge Rd., Braxton, MS 39044, (601) 863-6535; e-mail: kpcoc@aol.com; Web site: missgms.org

28—SPOKANE, WASHINGTON: Show, "Rings & Things BeadTour"; Rings & Things; Mirabeau Hotel Spokane Valley (Ballroom), 1100 N. Sullivan Rd.; Sun. 11-4; free admission; gemstones, bead strands, wholesale prices, findings, stringing supplies; contact Dave Robertson, P.O. Box 450, Spokane, WA 99210, (800) 366-2156; e-mail: drobertson@rings-things.com; Web site: www.rings-things.com/Show/city.php?city=Spokane

MARCH 2010

5-7—DEL MAR, CALIFORNIA: Show, "Gem Faire"; Gem Faire Inc.; Del Mar Fairgrounds/Exhibit Hall, 2260 Jimmy Durante Blvd.; Fri. 12-7, Sat. 10-6, Sun. 10-5; \$5 weekend pass; contact Yooy Nelson, (503) 252-8300; e-mail: info@gemfaire.com; Web site: www.gemfaire.com

5-7—NEWARK, CALIFORNIA: Show and sale; Mineral & Gem Society of Castro Valley; Newark Pavilion, 6430 Thornton Ave.; Fri. 10-6, Sat. 10-6, Sun. 10-5; adults \$6 (\$1 off flier on Web site), children under 12 free with adult; large, rare ice age fossils, fluorescent rock display, 60 display cases, 35 dealers, eight lapidary demonstrations, benefit auction; contact Larry Ham, P.O. Box 2145, Castro Valley, CA 94546, (510) 887-9007; e-mail: showchair@mgscv.org; Web site: www.mgscv.org

5-7—RICHMOND, INDIANA: Show; Eastern Indiana Gem & Geological Society; Wayne Co. Fairgrounds, 861 N. Salisbury Rd.; Fri. 9-6, Sat. 10-6, Sun. 11-4; adults \$4, seniors \$3, students \$1, children 6 and under free; contact John LaMont, 14158 St. Rd. 1, Brookville, IN 47012, (765) 647-4503; e-mail: Midwestchar@peoplepc.com

5-7—SARASOTA, FLORIDA: Show; Frank Cox Productions; Municipal Auditorium, 801 N. Tamiami Trail (Hwy. 41); Fri. 10-5, Sat. 10-5, Sun. 10-5; gems, jewelry, beads; contact Frank Cox Productions, 755 S. Palm Ave. #203, Sarasota, FL 34236, (841) 954-0202; e-mail: frankcox@comcast.net; Web site: www.frankcoxproductions.com

continued on page 70

GOLD SPECIMENS
GOLD NUGGETS
GOLD NUGGET JEWELRY

14Kt • 12Kgf

Sterling Silver
Lockets
& Findings

Easy Assembly

Satisfaction
Guaranteed

The perfect way to display your treasure.
Available in several shapes and sizes,
with and without gold.



We also
sell
GOLD!



Please visit our newly updated website for
quality gold specimens and nuggets.

MINER'S KEEPERS
PO Box 175, Sumpter, OR 97877

(800) 842-8655

www.minerskeepers.com
information@minerskeepers.com



Send \$1.00 for brochure
(Refundable with Order)



BARRANCA DIAMOND

Highland Precision Slab Saws

- ◆ 1-1/2 HP continuous duty commercial grade motor with thermal overload protection and manual reset
- ◆ Fully sealed drive shaft bearing housing
- ◆ Heavy-duty cast iron carriage and rock vise
- ◆ Screw drive vise carriage with automatic shutoff
- ◆ Silicon bronze clutch block carriage feed engagement system
- ◆ Variable feed rate (3 settings-pulley adjustable)
- ◆ Powder coated reservoir and zinc plated hood
- ◆ Inclined reservoir bottom for ease of sludge removal
- ◆ Heavy-duty casters with locking wheel brakes



HP18 \$3,595 on Sale

Part #: 8302020 List Price: \$4,140
HP18 includes a 20" (301 or 303S) diamond blade

HP24 \$5,325 on Sale

Part #: 8302024 List Price: \$5,850
HP24 includes a 24" 303S diamond blade

**SAVE OVER
\$500**

Sale Prices Valid
December 1, 2009 to
April 1, 2010

Crating cost \$250.
Freight quotes available.

BARRANCA DIAMOND Phone: 310-523-5867 Toll Free: 1-800-630-7682 www.barrancadiamond.com

GEM Center U.S.A. Inc.

4100 Alameda Ave., El Paso, TX 79905
P. (915) 533-7153 F. (915) 532-0244

Las Choyas



Trancas

Coyamito Agate

NEW STOCK COYAMITO AGATE



PRE-ORDER NOW!
1-877-533-7153

SHOWS 2010

Quartzsite, Arizona

Tyson Wells, Southwest Corner of I-10 &
Highway 95 Spaces B17-19 C17-C19,
Jan 1-10, 2010

Tucson, Arizona 2 Locations!!

1. TEP, Tucson Electric Park, 2500 East Ajo Way Tucson, AZ 85703, Space T12 (outside Tent #12), Jan. 31- Feb. 15, 2010
2. Tucson Gem & Mineral Society, 260 S. Church Street, Tucson AZ Convention Center, Space 16W, Feb 12-15, 2010

Visit our website www.gemcenterusa.com • cabs • beads • mexican geodes • rough material

MANY FACETS

by Guest Faceters

Faceters are welcome to submit their original designs for publication. Mail materials to Many Facets Submissions, *Rock & Gem* magazine, 290 Maple Ct., Ste. 232, Ventura, CA 93003.

I have been faceting for six years and have just taken up the art of gem design. This design is one that has worked out very well and, after checking in every resource I have, I could not find another design quite like it.

Feel free to adjust the crown angles up or down according to personal preference. I have cut the design adding up to 5 degrees in the crown, but I like the smaller table. Cutting the C2, C4 facets to a temporary center meet point helps keep the 3, 2, 1, look of the crown facets.

—David Hudson

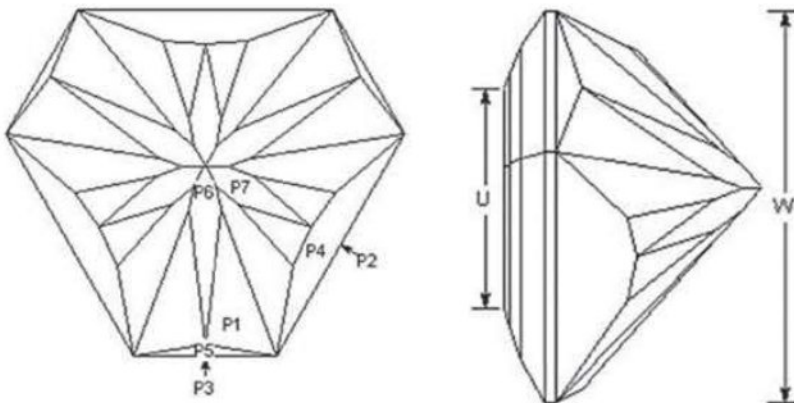
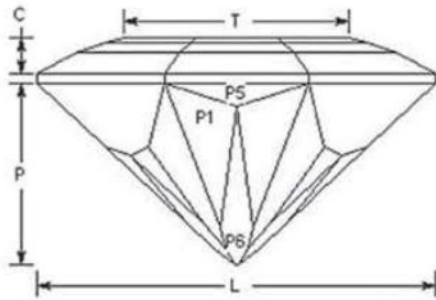

Linda's Toy
 Designed by: David Hudson
 Clip Corner Brilliant Trilliant, with step cut crown
 Angles for R.I. = 1.540
 49 + 6 girdles = 55 facets
 3-fold radial symmetry
 96 index
 $L/W = 1.155$ $T/W = 0.586$ $U/W = 0.507$
 $P/W = 0.527$ $C/W = 0.114$
 $Vol./W^3 = 0.261$

PAVILION

P1	43.00°	03-08-14- 18-24-29- 35-40-46- 50-56-61- 67-72-78- 82-88-93	Cut to CMP.
P2	90.00°	16-48-80	Cut girdle to P1, facet line is intersected.
P3	90.00°	96-32-64	Cut girdle to P1, P2 meet. Establish L/W with P2, P3.
P4	65.00°	16-48-80	Cut P1 to level girdle.
P5	65.00°	96-32-64	Cut P1, P4, P5 meet point.
P6	41.77°	96-32-64	Cut P1, P5, to CMP.
P7	41.94°	16-48-80	Cut P1, P4, to CMP.

CROWN

C1	34.00°	16-48-80	
C2	29.12°	96-32-64	Cut level girdle, .03 thick.
C3	24.00°	16-48-80	Cut girdle, meet C1, temporary CMP.
C4	20.19°	96-32-64	Cut to C3 meet point and temporary CMP.
C5	18.00°	16-48-80	Cut to C5 MP.
C6	15.02°	96-32-64	Cut this tier to personal likes.
C7	0.00°	Table	Level table, make C5 and C6 equal.

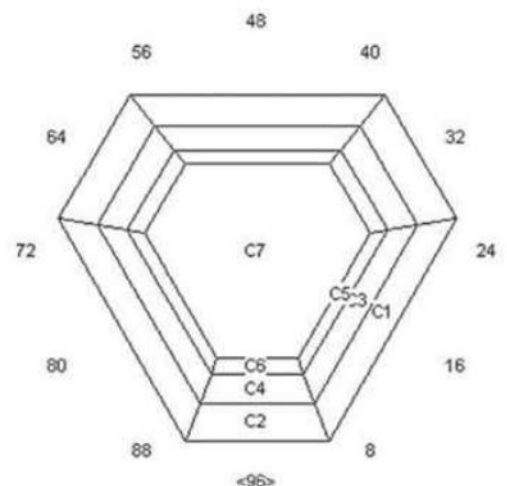



Covington Lapidary Machines Quality Built Since 1848



- * 16 Different horizontal machines to choose from.
- * From 8" Maxi-Laps to 16" production, one & two speed lapidary units.
- * 3 Automatic Vibra-Laps from 10" to 16" takes the work out of lapping.
- * Now proud manufacturer of the Rociprolap, 20", 24", 30" & 36", all models machined cast iron.
- * Maxi-Laps and Vibra-Laps made with heavy cast aluminum.



- * 6 Heavy Duty Slab Saws to choose from.
- * High performance slab saws for superior cutting, from 16" to 36". Blade is Included.
- * Six speed power feed with auto shut off.
- * Cross feed permits up to 8" of material to be slabbed without reclamping.
- * Completely assembled ready to plug in, add coolant, and operate.



Covington Engineering Corp.
P.O. Box 35 - 715 West Colton Ave.
Redlands, CA 92373

CALL US TOLL FREE (877)-793-6636
Outside U.S. (909)-793-6636
FAX (909)-793-7641

Visit us online at www.covington-engineering.com or www.covington-engineering.us



TYSON WELLS

Arizona's Largest Winter Attraction!



TYSON WELLS

Rock-Gem-Mineral Show

Quartzsite, Arizona

JAN. 1 - 10, 2010

A 10-DAY SHOW

- Gems • Rocks • Minerals • Jewelry •
- Silver & Goldsmithing • Faceting •
- Precious Metals •

Lapidary Tools, Equipment & Supplies

FREE ADMISSION • **FREE PARKING**
LOCATION AND DETAILS: S.W. Corner of I-10 Freeway and Highway 95, Quartzsite, Arizona, home of the largest show of its kind. • Takes days to see it all. • A buyers' and sellers' market of the world. • Smooth, fine graveled, dust controlled, packed surface for selling, parking and camping in the beautiful desert setting of Arizona's La Pos Valley. • Live on your show spaces or in our on-premises no-hookup campground with water and dump station. • Honey wagon available. • Easy access in and out of show. • Over 850 selling spaces on 25 acres. • This is a must see event.

TYSON WELLS 31st ANNUAL

SELL-A-RAMA Rock-Gems-Arts-Crafts Show

JAN. 15 - 24, 2010, A 10-DAY SHOW

A 25-ACRE OUTDOOR SPECTACULAR

An Unbelievable Variety Displayed on 2.2 Miles of Aisle Frontage

- Gems • Rocks • Minerals • Arts •
- Crafts • hobbies • Jewelry •
- Silver & Goldsmithing • Faceting •
- Precious Metals • Antiques • Coins •

TYSON WELLS

P.O. Box 60, Quartzsite, AZ 85346

Show Office Phone: (928) 927-6364 • For R.V. Office: (928) 927-6365

E-mail: tysonwells@tds.net

www.tysonwells.com

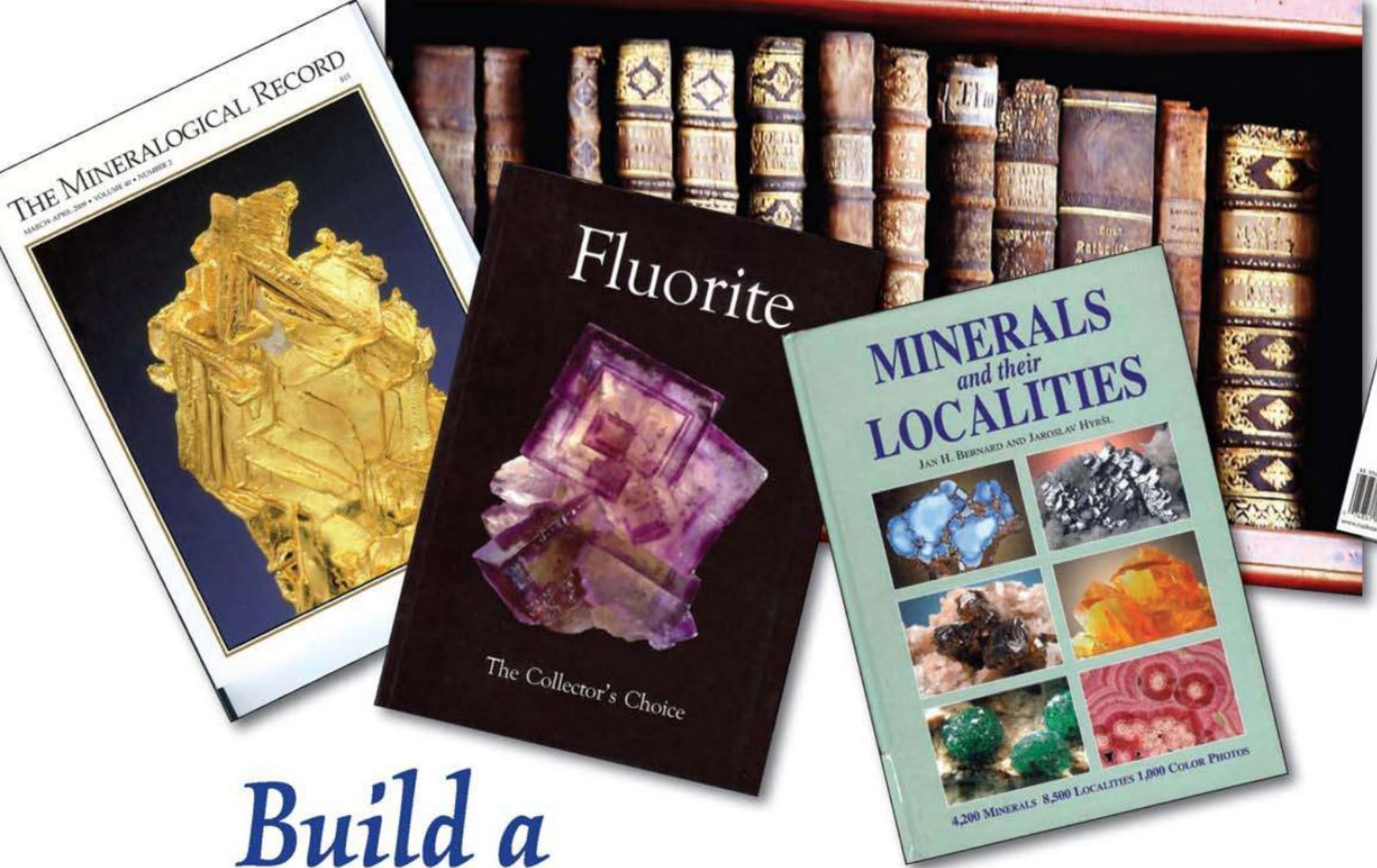

Build a MINERAL REFERENCE LIBRARY

A Good Library Expands Your Appreciation of Your Specimens

T Story by Bob Jones

There is much more to mineral collecting than acquiring specimens. Acquiring knowledge makes every specimen you collect far more enjoyable and treasured. A good mineral library expands your appreciation of your specimens and helps you get through the winter months, when the snows cover your favorite digging site, or the summer, when heat turns rock piles into barbecue pits.

There are lots of ways to learn more about the minerals you have. Talking to the collector or dealer from whom you obtained the specimen is a good way to supplement the information found on the accompanying label, but reading whatever you can about minerals is critical to enlarging your knowledge of minerals. This means the word "library" goes far beyond shelves of books! One obvious reason is that books tend to be out of date as soon as they are printed. Collectors must turn to other sources for the information that came to light after the manuscript was submitted.

The mineral label that comes with the specimen can be fascinating and informative, especially if the specimen acquired several labels as it passed through various hands over a period of time. As an example, one label I have for a fine franklinite specimen tells me it was once in the collection of the Smithsonian Institution, catalog number 47676. The specimen, a choice franklinite from the Trotter Mine in Franklin, New Jersey, had been gifted to the Smithsonian by R.O. Dwyer. In 1963, John Sinkankas made a specimen exchange

LEFT: *The Mineralogical Record* is an excellent reference for the advanced mineral collector.

CENTER: The superbly illustrated *Ex Lapis* is an English-language version of the German publication *Lapis*. Each issue treats one mineral or locality in depth.

RIGHT: *Minerals and Their Localities* describes more than 4,000 minerals and 8,500 mineral localities.

with the Smithsonian, and the franklinite became part of the exchange. The Sinkankas label—actually a file card—along with the original Smithsonian label, gives very detailed information. It describes the specimen as being "franklinite, calcite, a magnificent smaller specimen", "octahedrons" (the franklinites) "modified by dodec., hex. prisms of willemite". The label also gives the specimen value: \$55 at the time of acquisition and \$185 in 1968, which is apparently when the specimen was last appraised. The size of the specimen is also penned on the label, along with a catalog number. Such careful and complete labeling and cataloging certainly makes a specimen far more desirable. This information can also bring more questions to mind, such as, "Who was John Sinkankas?" Briefly, he was my mentor and a noted mineral author!

As useful as labels and card catalogs can be, books and magazine articles are the ultimate sources of information. Books can give you overall information about each mineral,



Rocks & Minerals is the oldest mineral magazine still being published today.

but they quickly become out of date, so you must turn to quality magazine articles for updates and recent findings. Still, books are the mainstay of any good mineral library.

Magazines have the advantage of being only a couple of months behind current events. They can report on the most recent mineral finds and academic discoveries, the latest shows, and new specimens appearing at shows. They can also provide specific information on the history and current status of mines, minerals, and new finds. Some club news bulletins also offer up-to-date news on minerals and are a good reason to belong to an active club.

BOOKS

Any library has to have a basic book suite. Such books actually range from textbooks over 100 years old to books less than a year old. Granted, collectors with limited funds really have to be selective, since the main emphasis in collecting is still the acquisition of mineral specimens. Within budgetary limits, however, mineral books are necessary. At the very least, your library should have several general textbooks on minerals, since they offer in-depth and historical information on the popular and common collector species, along with some discussion of testing techniques and crystal forms, and useful references in a bibliography.

My all-time favorite basic reference book is John Sinkankas' *Mineralogy for Amateurs*, first published in 1964. Paperback editions can still be found for sale at major mineral shows. The value of this book is John's easy-to-read descriptions of common minerals, which were written for the collector as much as for the student. It has very valuable sections on crystallography, mineral identification and testing, and mineralogical terminology, and a very extensive bibliography. In spite of its age, this text is still a very dependable reference.

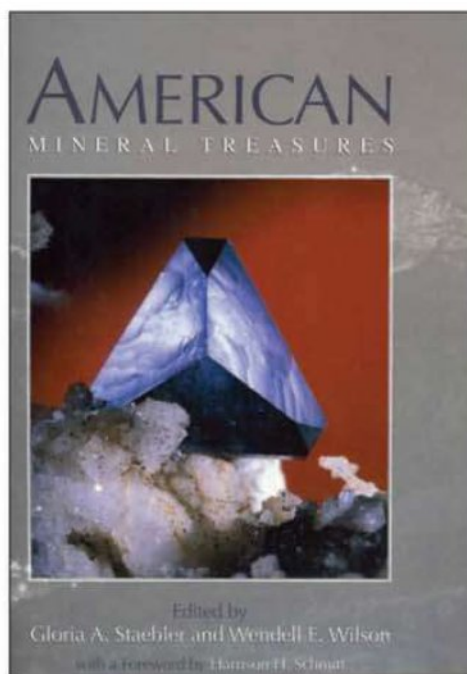

American Mineral Treasures describes in detail the minerals found in more than 40 noteworthy U.S. localities.

The first collector-oriented textbook I began using was Fred Pough's *Field Guide to Rocks and Minerals* (1953). It is now a part of the Peterson Field Guide series, and revised editions are still available in major bookstores. Like the Sinkankas book, this text is much more than descriptions of minerals. There are sections on testing minerals (including chemical testing, which I find very useful), crystallography, physical properties, and more. The Pough book has stood the test of time, having been revised and reprinted no fewer than eight times! I still reach for the Sinkankas and Pough books to refresh my memory on minerals and mineral properties.

There is a superb recently published reference book written by two European experts, Jan Bernard and Jaroslav Hyršl, which I find really useful. Titled *Minerals and Their Localities* (Granit Publishing House, 2004), this text is over 800 pages long and describes just about every mineral that was known at the time of publication. The descriptions, along with information on the localities in which they occur and excellent photographs, make this text a must for every collector's library. If you can afford only one recently published text on minerals, you may find that this one really meets your needs. You can find it at major mineral shows.

Another text I find particularly well written and very useful in understanding the entire field of mineralogy is George Robinson's *Minerals: An Illustrated Exploration of the Dynamic World of Minerals and their Properties* (Weidenfeld Nicolson Illustrated, 1994). Written in easy-to-understand language, the book offers every collector an overview of the geological conditions that produced minerals. By relating the rock cycle to plate tectonics, Robinson provides a clearer understanding of the various rock environments and the processes that result

in the formation of so many different minerals. He gives the reader an understanding of how geological processes produced the mineral deposits from which we get the specimens we collect. This text can also be found at major mineral shows.

A number of texts are now available that treat just one country or one mineral source. These are eminently useful if you tend to specialize in collecting one type of minerals. One such locality, Tsumeb, Namibia, dominated the specimen market with fine examples—many of them world class—of nearly 300 superb species in its heyday. The mines there are now closed, so I suggest collectors of these minerals obtain a copy of Georg Gebhardt's superb text *Tsumeb II* (G.C. Publishing, 1999). You may ask, "Why *Tsumeb II*? What happened to *Tsumeb I*?" It was published, but in German, while *Tsumeb II* is printed in English! The book sells for \$220 U.S., including shipping and handling, and can be ordered by e-mailing gctgg@t-online.de.

One of the most active sources of fine minerals today is China. I have written a couple articles for *Rock & Gem* on this vast and mineralogically fruitful country, but for years there was a dearth of reading material coming from China, as its government kept a lid on what could leave the country. Finally, in the 1980s, China opened its borders and the flow of fine mineral specimens began and has not stopped!

Fortunately, Guanghua "George" Liu wrote and produced the superb and very well illustrated book *Fine Minerals of China* (AAA Minerals AG, 2006). I was pleased to write the preface for this book and I use it frequently. This is a remarkable 365-page text with superb photographs by Jeff Scovil, George Liu, Raini Sischer, and Berthold Ottens. It describes in detail more than 100 Chinese mineral species and their localities. All are excellent collector species and are found in quantity. The book can be ordered from AAA Minerals AG, Baarerstrasse 10, CH-6300-Zug, Switzerland (www.aaamineral.com) for \$90, plus shipping and handling.

There are fine minerals coming out of the troubled countries of Afghanistan and Pakistan today. As of this writing, however, you have to turn to magazine articles, many of which are written by dealers who have risked life and limb going into these countries, for the most current information available on them.

Each book in the Butterworths Gem Books series addresses just one species and is a useful small reference. *Beryl*, by John Sinkankas and Peter G. Read (Butterworth-Heinemann, 1986), *Garnet*, by John D. Rouse (1986), *Quartz*, by Michael O'Donoghue (1987), *Corundum*, by Richard W. Hughes (1990), and *Topaz*, by D.B.

get
HANDS ON

DB-100™
Diamond Band Saw

Item# 91030 DB-100™
Diamond Band Saw
MSRP: \$239.95



Visit us in Tucson
at the InnSuites,
room 324

inland
www.inlandlapidary.com

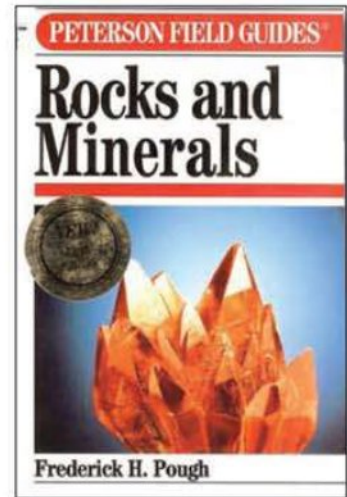

Fred Pough's *Field Guide to Rocks and Minerals* is an excellent book to take along on field trips.

Hoover (1993), are some of the titles in the out-of-print series. Copies are often available at major shows or secondhand through Amazon.com. The leading used mineral book dealer, Rocks of Ages, P.O. Box 674, Placitas, NM 87043 (www.rxofages.com), can also track down copies of these and other books that are out of print.

A quite useful, well figured text on quartz is *An Introduction to Crystalline Quartz*, by Harold Dibble (Dibble Trust Fund, 2002). This lovely book describes the many forms of quartz in all its varieties and properties. It does not go into great detail on localities, but for a complete understanding of this universally enjoyable mineral in all its odd and fascinating forms, this text is a good one to own. Order it from dibbletrust@adelphia.net.

There is one book that should be in everyone's library, even though it does not treat minerals in depth, nor does it include detailed information on localities. The book is the spiral bound *Fleischer's Glossary of Mineral Species, 2008*, edited by Malcolm Back and Joseph Mandarino. This is the most up-to-date listing of all recognized mineral species. Each alphabetical listing includes the mineral's chemical formula, crystal form, and type locality, along with the major reference in which it was first described. The book is available from Mineralogical Record, P.O. Box 35565, Tucson, AZ 85740.

MAGAZINES

Today, the best source of current information on species and localities—aside from actually being there—is magazines such as *Rock & Gem*, *Rocks & Minerals*, and *The Mineralogical Record*. These are the three significant U.S. mineral magazines being published regularly today. They cover the entire spectrum of mineral news: *Rock & Gem* provides information on minerals, field trips, and lapidary subjects that is geared to the average rockhound and collector. *Rocks & Minerals* magazine is more

William Holland School of Lapidary Arts

Classes from April through first week of November

For Information, please visit us on-line at

www.Lapidaryschool.org
or e-mail us Lapidary@WindStream.net
(706) 379 - 2126

P.O. Box 980, 230 Lapidary Ln., Young Harris, GA 30582

Classes Offered Include:

- Basket Making
- Beading (seed & reg)
- Cabochons - Casting
- Chain Making - Channel
- Enameling - Faceting
- Flameworking - Gem ID
- Gem Trees - Glass Beads
- Glass Fusing - Gold
- Intarsia - Jewelry Repair
- Kids Class - Mineral ID
- Opals - Polymer Clay
- Silver - Silver Clay
- Spool Knitting
- Stained Glass
- Wirewrapping
- Wire Sculpture

"The Original" SPENCER OPAL MINES

Located in Spencer, ID at North end of Opal Ave.

Mini Mine open 9:00 am to 5:00 pm during the summer.

Bring your own tools, eye protection required and **no** open toed shoes.

Show Dates

Fall 2009: Nov. 21: Unique Boutique Craft Fair, Idaho Falls, Idaho; Nov. 21-22: Oxnard Gem & Mineral Show, Oxnard, CA;

Dec. 5-6: Mojave Desert Gem & Mineral Show, Barstow, CA. **2010:** Jan. 20-24: Quartzsite Pow-Wow, Quartzsite, AZ;

Feb. 11-14: Tucson Gem & Mineral Show, Tucson, AZ; Mar. 12-14: Verde Valley Gem & Mineral Show, Cottonwood, AZ;

Apr. 9-11: Golden Spike Gem & Mineral Show, Ogden, UT

Summer Contact:
87 Opal Ave.,
Spencer, ID 83446
(208) 874-5476

www.spenceropalmines.com

Winter Contact:
P.O. Box 521
Salome, AZ 85348
(928) 859-8752



GEMS

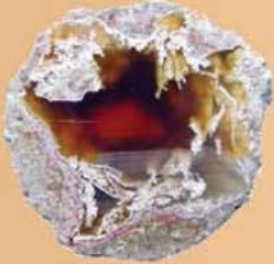

THE ROCK, GEM, MINERAL & FOSSIL SHOW

MARCH 6th & 7th, 2010

At The Klamath County Fairgrounds,
Klamath Falls, Oregon

Presented by

Rock & Arrowhead Club of Klamath Falls

Show Theme:

**"The Many Surprises of
Thundereggs and Geodes"**

DEALERS

Featured Gems
Opals, Jasper, Jade
One-of-a-Kind Art Work
Rough Rocks, Minerals, Fossils
Lapidary Supplies, Jewelry & Mounting
Tools & Equipment
Gold Panning Equipment
Bead Making & Supplies

DEMONSTRATIONS

Faceting Gemstones
Painting on Rocks
Thunderegg Cutting
Arrowhead Chipping
Channel Inlay
Soapstone Carving
Wire Wrapping
Sphere Making

*This project was partially funded by the
Klamath County transient room tax grant program.*

www.klamathrockclub.org 541.273.1102

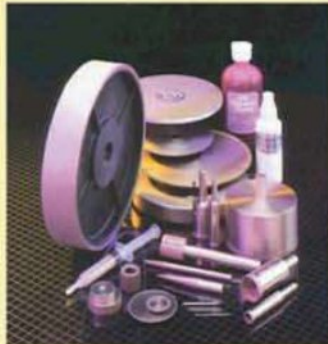

www.lapcraft.com

Is all you need to know for your diamond tool needs

Lapcraft, Inc. excels in the manufacture of standard as well as custom designed products in both diamond and cbn plated abrasives. Customer inquiries are invited.



DIAMOND WHEELS



DIAMOND DRILLS



DIAMOND SAW BLADES



DIAMOND DISCS

DOWNLOAD OUR CATALOG!



Lapcraft, Inc.®

CustService@Lapcraft.com

195 West Olentangy Street, Powell, OH 43065-8720 USA

Phone (614) 764-8993

Sales (800) 432-4748

FAX (614) 764-1860

MINERAL AND GEM ID TOOLS

Mineral Search Software

CD-ROM with photos, for any Windows PC, 670+ minerals. Identify/Catalog.

\$59

Free Demo online.



Refractometer

Measure R.I. of Gems to 1.81, includes R.I. fluid, light, case. **\$249**



Mineralab

2860 W. Live Oak Dr. G, Prescott, AZ 86305
1-800-749-3766 1-928-442-1155
www.mineralab.com
 MC/VISA/Amex/Disc Add \$7.00 S&H



Gem Tester

Colored Stone Estimator. Touch probe to rough, cab, faceted, or mounted stones. **\$219**

Geiger Counter

Detect radioactive rocks and minerals. Meter/ audio clicks to 50 mR/hr. **\$249**



Raytector 5-2 UV Lamp

Portable Combo SW LW, Rechargeable, two 6 watt bulbs, w/ 110V adapter. **\$289**

Hardness Picks

Metal points Mohs' 2 thru 9 with Streak Plate, Magnet, Wood case. Excellent Gift!

\$69



Specific Gravity Kit

For your Electronic Scale. Measures Specific Gravity of



Gems and Minerals. Specify version either for Bench Scale or Pocket Carat Scale. Easy to use! **\$79**

REFERENCE LIBRARY from page 58

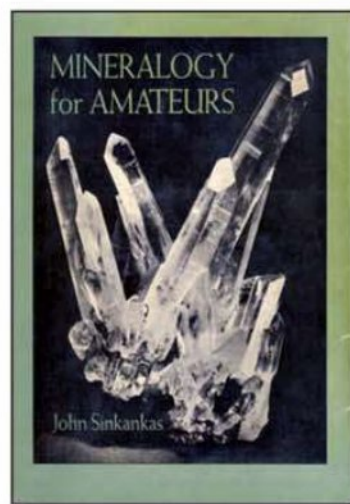

A classic reference to minerals, *Mineralogy for Amateurs* is still a great addition to any library.

technical, but still very readable and useful. Articles in this excellent bi-monthly publication include discussions of new and old localities, in-depth articles on the most recent discoveries of species and localities, and some historical data. *Rocks & Minerals*, first published in 1926, costs \$53 per year (www.rocksandminerals.org).

The third excellent magazine available today is the bi-monthly *Mineralogical Record*. It tends to be more scientifically oriented and caters to the advanced collector. It covers new minerals, important localities, and recent research, along with new discoveries. Collectors will probably find the section "What's New in Minerals" the most interesting, as it reports on all major shows, both U.S. (Tucson, Denver, the East Coast, Houston, etc.) and international (Munich, Germany, and St. Marie aux-Mines, France). These reports give readers useful descriptions of the newest species being offered for sale at these shows. The section also describes some of the old classic species that surface from older collections at these same shows. A one-year subscription is \$58.

Another magazine that is well worth enjoying looks at specific minerals or localities in each issue. *Lapis* (Lithiographie) is printed in the German language. If you can't read German, you can get the English-language version, *Ex Lapis*. This remarkable full-color magazine is a wonderful resource. One can hardly put each issue down, they are so informative and colorful. You can learn more about this useful magazine and order past and future issues at www.lithiographie.org.

Lithiographie also published a most interesting text that was released at the 2008 Tucson Gem & Mineral Show™. *America's Mineral Treasures* described in detail some of the great mineral finds made in America in the last 50 years. I wrote one chapter and contributed to another, so I have a vested interest in promoting this really excellent work. The text describes the experiences



World famous natural history gallery!!

Mineral & Gold Specimens
 Rare & Exotic Fossils
 Jewelry (Fine & Funky)
 Unusual Seashells & Corals
 Unique, One-of-a-Kind Gifts
 Books (New & Rare)
 Display Stands

Thursday - Saturday: 10 - 5
 Sunday: 12 - 5
 (or by appointment)
FREE PARKING!

**CLOSED: Monday,
 Tuesday & Wednesday**

KRISTALLE, est 1971

Wayne and Dona Leicht
 875 North Pacific Coast Highway
 Laguna Beach, California 92651-1415

(949) 494-7695; Fax (949) 494-0402

E-mail: leicht@kristalle.com - <http://www.kristalle.com>
 Visit our booth at most major mineral shows!

"I consider myself very lucky, having put off buying a new faceting machine until I met you and your wife at the Federation show. I marvel at the extreme accuracy of the Facetron." Robert Klien, Twin Fall, ID

"The Facetron is a fine technological creation with logical, thoughtfully placed controls which can meld man and machine into a single precision cutting unit."
 Stephen C. Gushue, Scranton, PA



- Digital Protractor
- Built-in Dial Indicator
- With Hard Stop

JARVI TOOL CO.

780 E. Debra Lane
 Anaheim, CA 92805
 714-774-9104 Fax: 714-774-9105
 e-mail: jtfacetron@earthlink.net
www.facetron.com



LORTONE, inc

Manufacturers of Equipment for Lapidary & Jewelry Artists



Classic Series Arbors

Our Classic Series arbors are the most affordable, durable arbors available! Re-designed after our original arbors, these powder-coated arbors feature 3/4" stainless steel shafts and removable top covers. Available in 6", 4 wheel & 8", 4 wheel models.

Professional Series Arbors

Perfect for the serious hobbyist or professional, these stainless steel arbors are precisely cut from corrosion resistant 304 grade stainless steel using our in-house CNC laser and then assembled with 3/4" stainless steel shafts. Available in 6" & 8" models.



Slab Saws
Arbors
Tumblers
Flat Laps
Trim Saws
Jewelry Tools
Abrasives
Geology Tools

12130 Cyrus Way, Mukilteo, WA 98275 • Phone: (425) 493-1600 • Fax: (425) 493-9494
email: equipment@lortone.com • www.Lortone.com

MINERAL of the MONTH CLUB SALE ON PRIOR YEAR SETS



Don't Miss Out on these Unique & Marvelous Minerals!!!

2009: Wulfenite, Lazurite, Uralite, plus 9 MORE

2008: Adamite, Stellerite, Zircon plus 9 MORE

2007: Phenakite, Brookite, Hematite plus 9 MORE

2006: Ruby, Cavansite, Crocoite, plus 9 MORE

2005: Celestine, Opal, Seraphinite, plus 9 MORE

SILVER LEVEL SETS:

(Smaller, study-size mineral)

Purchase 1 Year Set for only..... \$88.00

Add a Second Set for only..... \$77.00

Add a Third Set for only..... \$70.00

Add a Fourth Set for only..... \$63.00

Add a Fifth Set for only..... \$56.00

All 12 Educational Write-Ups are Included in each Set!

HURRYQUANTITIES LIMITED !!!

FREE SHIPPING on all minerals in the U.S.!!!!

Call **1-800-941-5594** or visit our web site at mineralofthemonthclub.org

GOLD LEVEL SETS
(Larger, display size minerals)
AVAILABLE TOO!

GY ROC® THE ULTIMATE IN JEWELRY FINISHING AND LAPIDARY EQUIPMENT & SUPPLIES

PREFORMER
8" and 10" TRIM SAW



Unique Design
Cuts Quickly and Accurately

**WRITE FOR
FREE LITERATURE
AND LOCATION
OF YOUR
NEAREST DEALER**

Dealerships And
Distributorships
Available

VIBRAHONE



Available in 3 Sizes
2.5 lbs.-10 lbs.-40 lbs
Produces Unequaled Results
For Grinding And Polishing
Stones And Finishing Jewelry

CABBER



Easy To Use
Forms Precision Domes
For The Professional
And Amateur.

TAGIT®

Manufactured by
P.O. Box 1534, San Juan Capistrano, CA 92675
(562) 949-8380 (949) 496-7742

REFERENCE LIBRARY from page 60

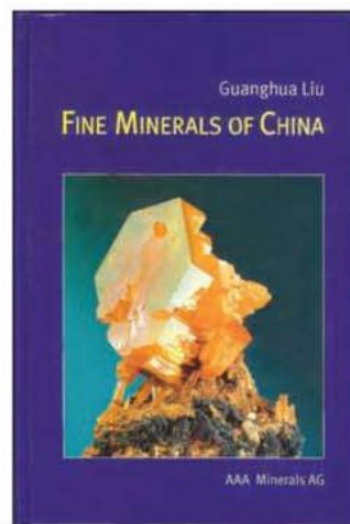

With so many minerals coming from China today, this text is a must in every collector's library.

of the collectors and miners who actually mined the fine minerals we now enjoy (rhodochrosite, epidote, calcite, fluorite, beryl, benitoite, and others) from famous localities such as Bisbee and Tiger, Arizona; Franklin and Sterling Hill, New Jersey; Mount Mica, Maine; and California's gold and pegmatite deposits—more than 40 in all.

Supplementing the monthly magazines are smaller news publications that are put out within weeks or even days after a new find. One such excellent publication is *Mineral News*, a monthly newsletter. Subscribe for \$28 per year by writing to P.O. Box 3088, Peekskill, NY 10566.

INTERNET

Don't forget the Internet; it's a good, quick source of mineral data. Just type in a mineral name and see what pops up! There are databases of information, pages that are continuously updated with the latest news, and sites that allow you to exchange information with other users.

I use two computers. One is hooked to the Internet and is used for reference searches and online communication. Like all computers hooked to the Internet, it is susceptible to spam and viruses, and is equipped with the appropriate software to combat these threats. It is this computer that gives me access to excellent resources about minerals, fee digging localities, museums, etc. My second computer is my working computer. It is not hooked to the Internet, so I don't have to worry about viruses destroying my information files. I do all my writing and important work on this isolated computer.

The library and magazine subscriptions of every collector are going to vary according to personal interest and financial ability. By going to shows, checking book dealers' shelves and talking with other collectors and dealers, you can best determine what you need and enjoy as you move deeper into our great hobby. ♦

NORTHWEST DISTRIBUTORS, LLC



Maps Maps Maps

Find the mineral deposits and mining sites of 100 years ago. 5 maps, 17.5 x 23, printed on both sides. Early stage roads & town sites shown. Many rock & gem deposits included. Price \$12.95 each plus postage. AZ-CA-CO-ID-MT-NM-NV-OR-WA
www.maps-nwd.com
(877) 791-3500

South Pacific Wholesale

114 River Street, Montpelier, VT 05602

Semi-Precious Stone Beads

Freshwater Pearls

Goldfilled & Sterling Beads and Findings

Stringing Materials

Since 1977 and that's forever in the Bead Business.

www.beading.com

**THUMLER'S
TUMBLER
ULTRA VIBE**

Order Toll Free: 1(800) 225-1017
<http://www.thumlerstumbler.com>

Building Tumblers for Hobby & Industry Since 1959



- 30 Models & Kits
 - 1 qt - 4¾ gal.
- Thermally Protected
 - Durable & Safe
- All Steel Construction

**Write for
Catalog**



Tru-Square Metal Products • P.O. Box 585 • Auburn, WA 98071

**DESERT GARDENS 10TH
ANNUAL INTERNATIONAL
GEM, MINERAL
& JEWELRY SHOW**

JANUARY 1 – FEBRUARY 28, 2010

*A select group of dealers from around the world.
(RETAIL & WHOLESALE)*

**GEMS * MINERALS * PETRIFIED WOOD
ROUGH ROCK & SLABS
ROCKHOUND & LAPIDARY SUPPLIES
JEWELRY * CRYSTALS * BEADS
ROUGH & CUT STONES * FACETING
SILVER & GOLD SMITHING
FOSSILS * CARVINGS
LEATHER & MUCH MORE**

CALL (928) 927-6361 FOR MORE INFORMATION
JUST OFF EXIT 17 ON INTERSTATE 10
QUARTZSITE, ARIZONA

**FREE PARKING
FREE ADMISSION
FOOD COURT**



Wholesale prices on Australian Opal jewelry inlaid with gold. Jade, Petrified Wood, Limbcast Agate, Landscape Jasper, Chalcedony, Chrysoprase, Dinosaur Bone, and more.

See our inventory at
IN A FLASH OPAL INLAY
www.inaflashopalinelay.com

(Read about us in Rock & Gem's
Opal issue, October 2009.)

To receive a free catalogue please contact us.

Tony: (801) 792-6027, email: tthurber@q.com

Eric: (801) 359-1499, email: ethurber@q.com

Quartzite: Wells, Pow Wow • Tucson





The

R&G Shopper

Mineral Specimens: Agates & Mounts. Full color Catalog, 44 pages with over 150 color pictures. \$5.00 refund with order.
PICKENS MINERALS
 610 N. Martin Ave. Waukegan, Illinois 60085
 email: picmin@sbcglobal.net
 Ph: 847-623-2823
www.pickensminerals.com

B&J ENTERPRISE
 Rock Shop Specializing in
 Silver & Gold Jewelry, Gemstone & Glass
 Beads and Unique Gifts
 106 East "B" Street (Hwy 30)
 P.O. Box 84, Rainier, OR 97048
 (503) 556-2543

WAX PATTERNS
AU-RUS Wax Patterns
 5500+ Patterns Online
 302 Main Street, Kellogg, Idaho 83837
 (208) 786-9301
 website: www.auruswaxpatterns.com

Diamond Core Drills
Lapcraft Inc. USA
 195 W. Olentangy Street • Powell, OH 43065
 Ph: (614) 764-8993 Fax: (614) 764-1860
www.lapcraft.com E-mail: custservice@lapcraft.com
1-800-432-4748

CarTopCamper.com
 Sleep comfortably
 above the rocks,
 mud & critters.
\$795 (plus shipping)

METEORITES
 Rare Rocks From Space
 I have many excellent specimens at great prices.
 Send for a **FREE** paper list, OR sign-up for
FREE periodic e-lists at:
[brMeteorites_list](mailto:brMeteorites_list@yahoo-groups) under Yahoo-groups.
 Blaine Reed - Meteorites
 P.O. Box 1141, Delta, CO 81416

FREE CATALOG
 THE #1 SOURCE to THE TRADE
 ALL TYPES ROUGH & CUT GEMS
KNIGHT'S BOX 411 WAITSFIELD VT 05673
 FAX 1-802-496-5619 TEL 1-802-496-3707
 e-mail - knights@madriver.com

FREE TREASURE RESEARCH CATALOG
 BOOK - MAPS
 VIDEOS - ALL SUBJECTS - LOW PRICES
1-800-345-8588
 Research Unlimited, Oscoda, MI 48750

NORTH COAST FACETING IS AN AUTHORIZED, VALUE ADDED
 DEALER FOR **FACETRON** AND **POLYMETRIC INSTRUMENTS**.
 WE TEACH YOU TO USE THE EQUIPMENT WE SELL.
 LEARN FROM JIM PERKINS, CERTIFIED AWARD WINNING FACETER.
 LEARN TO USE GEM CAD, BASIC OR ADVANCED,
 FLAT OR CONCAVE FACETING. TELEPHONE: 330-725-6070
www.northcoastfaceting.com

www.finemineralshow.com
 Westward Look Show
 Houston Fine Mineral Show
 San Francisco Fine Mineral Show
info@finemineralshow.com

Kino Rocks & Minerals
 Mineral Specimens • Bookends
 Jewelry Findings • Slabs & Rough
 Custom Sawing • Lapidary Supplies
 NO CATALOG
 6756 S. NOGALES HWY., TUCSON, AZ 85756
 (520) 294-0143

PEWTER FIGURINES
 100's OF STYLES
 HIGH QUALITY WHOLESALE PRICES
 FREE CATALOG
 IMPERIAL MFG.
 14502 Resort Ln., Lakewood, WI 54138
 (715) 276-7865

Advertising Works
Be Seen By Thousands
 For more info call Brian at 623-327-3525

The Mineral Gallery
 Minerals and Crystals
 Top Quality Cabinet Sizes Our Specialty
 Visit Our Web site and Online Mineral
 Auction Complete with Color Photos at:
<http://www.themineralgallery.com>
 PO Box 91448, Mobile, Alabama 36691

MarZee Lapidary Tutorial DVDs
BEGINNING CABOCHON. FLAT LAP. LAPIDARY DRILLING. SLOW WOOD LAP. BEGINNING FACETING.
 63 Park Hill Ave., San Francisco, CA 94117
 email: marzeetutorials@znet.com
 web: <http://marzeetutorials.com>

Welcome to the ROCK&GEM Shopper, the one-stop shopping place for your rockhounding and lapidary needs. Every month many thousands of shoppers will browse through this convenient shopping section.

To be part of the Shopper,
call Brian Roberts at: 623-327-3525
or email: broberts@jmillermmedia.com



PrettyRock.com
Gemological Tools,
Faceting Rough &
Lapidary Supplies
704-299-2853
POB 38930 Charlotte NC 28278

**On
the
Rocks**
Gems, Jewelry & More
5709 N. Clark St. Chicago, IL 60660
(773) 649-0111
visit us online:
www.ontherocksinc.com

WHOLESALE

PAUA SHELL Bracelets ...
HEMATITE Necklaces, Rings ...
COPPER Jewelry ...
MAGNETIC Wraps ...
Tel: 352-338-3576
website: www.jscopti.com

**FIRE MOUNTAIN
GEMS and Beads®**
"Friendly Service" Since 1973
One Fire Mountain Way, DEPT C012 Grants Pass, OR 97526-2373
www.firemountaingems.com/freecatalog

**Dig Cuesta
Fire-Agate**
Oatman, AZ
\$20.00 a day
Don Nelson (928) 565-4145

**DIAMOND PACIFIC
TOOL CORPORATION**
Call or write for your FREE copy of our 2009 catalog.
1(800) 253-2954 diamondpacific@aol.com

OXY ROCKS
THE GEM AND MINERAL CLEANER
PROVEN
Cleaning product, safely removes calcium, organics, rust and other deposits, leaving your specimens sparkling. Revolutionary discovery created in lab for you! Repairs harsh chemical burns. Efficient cleaning. No noxious fumes.
DISTRIBUTED EXCLUSIVELY BY
OXYROCKS.COM

Dragonsaye Auctions
An auction site dedicated solely to the lapidary trade.
Find supplies, rock, slabs, handcrafted precious metal jewelry and equipment all in one place.
Great seller perks! NO Final Value Fees, user-friendly
Paypal and Credit Cards.
\$15.00 free-credit to early applicants.
See more at
www.dragonsayeauctions.com
Ask for Dragon 410-437-9695

LAPIDARY EQUIPMENT

* Ameritool * Barranca
* Diamond Pacific
* Covington Engineering
* Gryphon and More!!
JS GEMS
phone: (909) 519-1545; e-mail: jsgems@dslextreme.com
www.jsgemslapldary.com
Our slogan is "Quality lapidary equipment at discount prices"

Mineral Specimens
Cut & Uncut Gemstones
New & Used Lapidary Equipment
CRYSTAL CAVE
6835 Stirling Rd., Davie, FL 33314
(954) 585-8988 FAX: (954) 585-8989

JEANNE'S ROCK & JEWELRY®
www.JeannesRockShop.com
PHONE: 713-664-2988 FAX: 713-664-1714
· LW & SW FLUORESCENT MINERALS ·
· DISPLAY STANDS - PLEXI & WOODEN COBRA ·
· DISPLAY ITEMS - TRAYS, PADS, ZIPS & MORE ·
· CABOCHONS - STAUROLITE CROSSES ·
FOR LISTS: SEND \$1 AND BUSINESS ID/INFO
IN SOUTHWEST HOUSTON SINCE 1972

Prospecting Maps
**GOLDMAPS
.COM**
(321) 783-4595

MILS[®]

Minnesota Lapidary Supply

**"YOUR LAPIDARY
GENERAL STORE"**

For EQUIPMENT and SUPPLIES

HOME OF:

TXP POLISH

Micron sized aluminum oxide based polishing compound. Simply put the best all around rotary tumbler polish I have ever used!!!!

#61 RAPID POLISH

Sub-micron sized aluminum oxide based polishing compound. It will provide a superior polish in vibratory tumblers and hand lapping on most stones!!!!

Minnesota Lapidary Supply

201 N. Rum River Drive

Princeton, MN 55371

Ph/Fax: (763)-631-0405

e-mail: sales@lapidarysupplies.com

Our Hours are:

Sun. & Mon. --- Closed

Tues. thru Fri. --- 9:00 a.m. to 5:00 p.m. CST

Sat. --- 9:00 a.m. to 4:00 p.m. CST

DISPLAY STANDS

Free Catalog

For Eggs, Geodes, Fossils, Meteorites, Spheres, Shells, Slabs, Rocks and more. BUY direct from the manufacturer.

Sylmar Displays

P.O. Box 3726-R

New Haven, CT 06525-0726

203 393-1059

203 393-2457 fax

www.sylmardisplays.com

Wholesale Catalog with Resale Number



METEORITES

BEAUTIFUL GEMS FROM SPACE

Museum-Quality collectors' display and study specimens. Meteorite jewelry, books, collecting kits, unique gift items. Authenticity guaranteed.

The Universe Collection

P.O. Box 3726-R

New Haven, CT 06525-0726

203 393-3395

203 393-2457 fax

www.universecollection.com

Color Catalog

\$3 USA, Canada and Mexico

\$6 Foreign

Refundable with order

VISA • MC • AMEX

OFF THE DOP

by Jim Perkins

Faceting Machine Maintenance

Recently, while I was speaking to Jeff Jarvi of Jarvi Tool Co. (www.facetron.com), makers of the Facetron™ faceting machine, he reminded me that we faceters need to take some time to maintain our machines. I have worked since 1973 as a machine tool field engineer and I see the results of poor machine maintenance on a daily basis, so I could easily relate to what Jeff was telling me. As a manufacturer, however, Jeff sees specific problems caused by lack of maintenance. Since he is more knowledgeable than I am about his machine, I listen closely to his advice.

These days, faceters use diamond as a polishing medium more than ever before, and the rock, water and diamond leave a residue that is very abrasive and sticks to machine parts like glue, causing excessive wear if we don't clean it away regularly. Jeff advises washing the machine down liberally and keeping it well lubricated. I use Formula 409® spray cleaner and paper towels to clean away the dirt and clean out the splash bowl. Then I remove the mast tube from the machine and the faceting head from the tube so I can clean those parts and lubricate them all with WD-40®. The mast should be removed from the base plate and cleaned where it slides on the base and lubricated before reassembly. Anywhere two pieces of the machine meet, I spray on lubricant and let it soak in. Remove the index gear and clean the index teeth with a toothbrush under running water.

Lubricate everything before reassembly. Jeff also recommends spraying WD-40 into the dop chuck orifice, to clean away dirt and maintain the dop chuck cam lock mechanism, and removing the faceting head, turning it over and spraying lube in the 3/8-inch hole to keep the dial indicator action moving smoothly. Of course, oil attracts and holds dirt, making an abrasive paste, so maintaining your machine is a continuing process. Following Jeff's maintenance tips has saved a lot of wear and tear on my machines and made them more enjoyable to use; a clean machine in top operating efficiency simply works better, in my opinion.

Jeff also told me to plug my Facetron into a Ground Fault Circuit Interrupter (GFCI) outlet. They are standard on all new Facetrons. If you have an older model, you can purchase one (item # 08667099) from MSC Industrial Supply Co. (

mscdirect.com/cgi/nnsrhm). I purchased them for my machines, including my Genie cabochons machine, as it is good protection at very little cost.

Whenever a machine has a breakdown or electrical problem, it is always best to contact the manufacturer directly and send it into them for repair and or upgrade. The manufacturer may find other parts that are worn or bad. The cost of shipping is cheap compared to the service a machine manufacturer provides.

In my experience, owners who tinker with their machines usually find they cause more problems than they cure. The faceting machine manufacturers know their machines best and have all the parts and equipment to repair or upgrade your faceting machine to like-new condition. Each manufacturer has its own policy on handling repairs, so check with yours before sending in your machine. Jeff and his wife, Jeanne, have been outstanding for my customers and me through the years.

In some cases, manufacturers will recommend other upgrades to improve your machine's accuracy or reliability at a cost to cover parts. I've always found Jeff's directions helpful and am always happy I followed his advice.

Good faceting and safety begin by keeping your work area clean, organized, and well illuminated, and by practicing routine preventative maintenance. You'll gain the most enjoyment from your equipment and preserve your investment in it.💎

Send your comments and questions about any of my columns to Off the Dop, P.O. Box 1041, Medina, OH 44258, or e-mail me at jimperkins@zoominternet.net.





BARRANCA DIAMOND HIGHLAND PRECISION 14" SLAB SAW

Save
\$300
Through
4/1/10



Made in
the USA

Barranca Diamond introduces the HP14 Table Top Slab Saw. It is engineered for accurate, smooth cuts and easy to operate. Its an ideal slab/trim saw for rocks, minerals, and glass.

- ◆ 3/4 HP continuous duty motor with thermal overload protection and manual reset
- ◆ Heavy-duty cast iron carriage and rock vise
- ◆ Screw drive vise carriage with automatic shutoff
- ◆ Silicon bronze clutch block carriage feed engagement system
- ◆ Powder coated reservoir and hood
- ◆ Splash-style lubrication and cooling system
- ◆ Includes a 14" 301 Supreme Rim Diamond Blade

HP14 \$1,695 on Sale

Part#:8302014 List Price \$1,995

Optional saw stand: Part# 166153 List Price \$100



**14" 301 Supreme
Rim Diamond Blade**

Part# 166070

List Price: \$312

Sale: \$250

Sale prices valid through April 1, 2010, FOB Torrance, CA

BARRANCA DIAMOND | Phone 310.523.5867 | Toll Free: 1.800.630.7682 | www.barrancadiamond.com

www.METALLIFEROUS.com

online shopping now available
offering everything
to create beautiful jewelry

- Sterling Silver
- Findings
- Vintage Beads
- Tools
- Swarovski
- JAX Chemicals
- Books



Receive a **FREE** pair of pliers with any \$50 order
enter code QEV at checkout



www.johnbetts-fineminerals.com



John H. Betts - Mineral Dealer

www.johnbetts-fineminerals.com

Cash paid for mineral collections!

2010

Lapidary Article of the YEAR CONTEST

SPONSORED BY



WHO IS ELIGIBLE

U.S. residents only, age 18 and older.

HOW TO ENTER

Submit a step-by-step lapidary project article to *Rock & Gem*. For submission guidelines, visit www.rockngem.com/submissions.asp or write to *Rock & Gem* Writers' Guidelines, P.O. Box 6925, Ventura, CA 93006-9899.

"Lapidary" is defined as the working of precious or semiprecious gem materials or metals into an ornament to be worn or decoratively displayed. How-to stories dealing with the building of lapidary tools, display paraphernalia, and other items are welcome, but are not eligible for the contest.

Authors must complete and return a Contributor Agreement and W-9 form before their entry will be considered for publication. Contact Managing Editor Lynn Varon at (805) 644-3824 ext. 129 or editor@rockngem.com for these forms.

All conditions and requirements of the writers' guidelines and the Contributor Agreement apply.

All step-by-step lapidary projects published in 2010 cover date issues of *Rock*

OFFICIAL CONTEST RULES

& *Gem* are eligible for the 2010 contest, regardless of the year of submission, and will be automatically judged.

The number of lapidary project submissions received may exceed the available space. *Rock & Gem* publishes approximately 6 to 12 project article per year.

The authors of all published articles will receive normal payment for the article, as determined by the editor.

If a winning entry was contributed by a separate author and photographer or by multiple authors, one prize will be awarded to the contributors, to be divided as they see fit.

JUDGING

Articles will be judged by a combination of reader response and editorial merit. Readers should send a brief explanation of why a project deserves the big prize to 2010 Lapidary Article of the Year Contest, *Rock & Gem* magazine, 290 Maple Ct., Ste. 232, Ventura, CA 93003 or to editor@rockngem.com.

Don't wait to send in your vote! The deadline for 2010 votes is January 1, 2011. The winner will be notified by January 17, 2011.

Readers may vote for more than one article per year, but are limited to one vote per article.

The final decision will be made by the Managing Editor of *Rock & Gem*.

THE PRIZE

The winner will receive a complete faceting package from Lapcraft Inc. that includes four 8-inch faceting laps (a 360 Islander, a 1200 standard, a 3000 standard, and a Finalap with 50000 diamond slurry), a bottle of 50000 diamond spray, an 8-ounce bottle of Tool Cool, and a DiaLaser diamond saw blade in the winner's choice of size (4 to 8 inches). It is valued at \$550.



Lapcraft Faceting Package

Rodeway Inn - NO!

Quality Inn - NO!

Grant Inn - Yes!

**Same GREAT Show
Same Location
just a new name**

**Tax License Required
Wholesale Only!**

**For More Information Contact:
Gem & Lapidary Wholesalers, Inc.
P.O. Box 98 Flora, MS 39071**

Phone 601.879.8832 • Fax 601.879.3282

E-mail info@glwshows.com • www.glwshows.com



Join  in

**Tucson
2010**

**at the
Grant Inn
I-10 at Grant Road**

**January 30 thru
February 12, 2010**

**Register Online
@ glwshows.com
for your Tucson
Buyer Badges**

**ROCK'S GEM TRIM SAWS & BULL WHEEL ARE
TIME TESTED MACHINES MADE OF HEAVY DUTY
CAST ALUMINUM AND MADE IN THE U.S.A.**



**FEATURES OF 4" & 6"
HIGH SPEED GEM TRIM SAWS**

Solid cast aluminum construction.
Attractive and durable powder coat finish.
8 ft power cord.
3000 rpm motors.
1/2" arbor.
MK-303 Saw blade included.
Package of Crystalcut included.
Made in the USA.

FEATURES OF THE BULL WHEEL

Complete unit with balanced wheels.
Solid cast aluminum construction.
Attractive and durable powder coat finish.
4" x 12" expanding sanding wheel. (4 belts included)
12" flat disc with sponge rubber. (4 disc included)
12" convex disc covered with leather over a sponge rubber backing.
3/4 hp 120v 60hz motor.
Quick change motor mount.
8 ft power cord.
Made in the USA.



POLARIS
TOOL & MACHINE

DEALER INQUIRES WELCOME

P.O. Box 248, Wellington, OH 44090 Phone # 419-929-8575 Fax # 419-929-2913

Email: info@polaristool.com Website: www.polaristool.com

get
HANDS ON

SwapTop™

6" & 8" Flat Lap Machines

Item# 10680 SwapTop™
6" Flat Lap Machine
MSRP: \$289⁹⁵

Item# 10880 SwapTop™
8" Flat Lap Machine
MSRP: \$369⁹⁵



Visit us in Tucson
at the InnSuites,
room 324

inland
www.inlandlapidary.com

Show Dates from page 52

MARCH 2010

6-7—ARCADIA, CALIFORNIA: Show; Monrovia Rockhounds; LA County Arboretum, 301 S. Baldwin Ave.; Sat. 9-5, Sun. 9-5; adults \$7, students and seniors \$5, children \$2.50; more than 15 vendors, rocks, gems, jewelry, minerals, fossils, wire wrapping, findings, beads, grab bags, Treasure Wheel, Fossil Find; contact Jo Anna Ritchey, 224 Oaks Ave., Monrovia, CA 91016, (626) 359-1624; e-mail: joan.ritchey@gmail.com; Web site: www.moroks.com

6-7—BIG SPRING, TEXAS: 41st annual show; Big Spring Prospectors Club; Howard County Fair Barn; Sat. 9-5, Sun. 10-5; dealers, demonstrators; contact Jerald Wilson, 707 Tulane, Big Spring, TX 79720, (432) 263-4662 or (432) 263-3340

6-7—CALDWELL, IDAHO: Show, "Collecting Gems for 2010"; Owyhee Gem & Mineral Society; O'Conner Field House, 2200 Blaine; Sat. 10-6, Sun. 10-5; contact Carolyn Roberts, (208) 466-6191; e-mail: ncrobertsrp@msn.com

6-7—ISSAQUAH, WASHINGTON: Annual show; East KingCo Rock Club; Pickering Barn, 1730 10th Ave. NW; Sat. 10-5, Sun. 10-5; contact Norma Kikkert, c/o EKCR, P.O. Box 2203, Redmond, WA 98073, (206) 612-3113; e-mail: eastkingco@gmail.com

6-7—KLAMATH FALLS, OREGON: Annual show, "Thundereggs"; Rock & Arrowhead Club; Klamath County Fairgrounds, 3531 S. 6th St.; contacts Garwin Carlson, (541) 882-8276, or Marv Stump, (541) 882-8341

6-7—SAN FRANCISCO, CALIFORNIA: Show, "San Francisco Crystal Fair"; Pacific Crystal Guild; Fort Mason Center, 99 Marina Blvd.; Sat. 10-6, Sun. 10-4; admission \$6; contact Jerry Tomlinson, (415) 383-7837; e-mail: sfxl@earthlink.net; Web site: www.crystalfair.com

6-7—STANTON, DELAWARE: 47th annual Earth Science Gem & Mineral Show and Annual EFMLS Convention; Delaware Mineralogical Society; Delaware Technical & Community College, I-95 Exit 4B, Churchmans Rd. (Rte. 58); Sat. 10-6, Sun. 11-5; adults \$6, seniors \$5, juniors \$4, children under 12 free with adult; exhibits, displays, dealers, minerals, gems, fossils, gems, jewelry, lapidary supplies, door prizes, lapidary demonstrations, children's booth, grab bags; contact Wayne Urion, (302) 998-0686; e-mail: wurion@aol.com; Web site: www.delministry.net

6-7—VENTURA, CALIFORNIA: 48th annual show, "The Ventura Gem Show"; Ventura Gem & Mineral Society; Seaside Park (Ventura County Fairgrounds), 10 W. Harbor Blvd.; Sat. 10-5, Sun. 10-4; free admission; dealers, displays, gems, minerals, fossils, lapidary art, demonstrations of lapidary arts and jewelry making, door prizes, silent auctions, "Country Store", children's activities; contact Andy Anderson, (805) 987-0043; e-mail: vgm_editor@roadrunner.com; or Kathryn Davis; e-mail: kathryngems@yahoo.com; Web site: www.vgms.org

11-14—DEMING, NEW MEXICO: 45th annual show, "Rockhound Roundup Gem & Mineral Show"; Deming Gem & Mineral Society; SWNM Fairgrounds, Raymond Reed Blvd.; Thu. 9-5, Fri. 9-5, Sat. 9-5, Sun. 9-5; free admission; more than 100 dealers, demonstrations, displays, field trips, jewelry, rocks, drawings, cash raffle, silent auction Fri., live auction Sat.; contact Jerry & Carolyn Abbey, P.O. Box 1459, Deming, NM 88030, (575) 543-8916; e-mail: theDGMS@gmail.com; Web site: dgms.bravehost.com

12—HOUSTON, TEXAS: Show, "Rings & Things BeadTour"; Rings & Things; Holiday Inn Southwest, 11160 Southwest Fwy.; Fri. 12-4; free admission; gemstones, bead strands, wholesale prices, findings, stringing supplies; contact Dave Robertson, P.O. Box 450, Spokane, WA 99210, (800) 366-2156; e-mail: drobertson@rings-things.com; Web site: www.rings-things.com/Show/city.php?city=Houston

12-14—COTTONWOOD, ARIZONA: Show, "Verde Valley Gem & Mineral Show"; Mings Gem & Mineral Club; Verde Valley Fairgrounds, 800 E. Cherry St.; Fri. 9-5, Sat. 9-5, Sun. 10-4; adults \$1 (Fri.) and \$3 (Sat./Sun.), children free with adult; worldwide minerals and gems, fine and costume jewelry, gem and mineral displays, raffles, silent auctions, jewelry, lapidary tools, supplies, equipment, children's activities, free mineral and gem identification; contact Sue Valek, (928) 634-7452; e-mail: Queen3bbas@aim.com

For more Show Dates, go to www.rockngem.com.



TIRED OF HIGH TOOL COSTS? ME TO. SO I CALLED.
DANIEL LOPACKI CO.

P. O. BOX 144 CLIFF, N. M. 88028
TOLL FREE 1-888-593-9462 INTERNATIONAL 575-535-2524

DIAMOND SAW BLADES	WE STOCK OVER 200 INDIVIDUAL CARVING BURRS	DIAMOND GRINDING WHEELS
4"X1/2"X.008" \$ 7.95	EASTWIND DIAMOND ABRASIVES BELTS & DISCS & FLEXWHEELS	60 MESH \$162.00
4"X1/2"X.024" \$ 10.50	DIAMOND FILE SETS NEEDLE OR RIFFLER	80 MESH \$144.00
4"X5/8"X.008" \$ 7.95	5 PIECE SET \$10.95 10 PIECE SET \$16.95	100 MESH \$144.00
6"X1/2"X.012" \$ 10.50	DIAMOND POWDER 5CT \$8.50	180 MESH \$120.00
6"X5/8"X.012" \$ 10.50	GREAT ASSORTMENT DIAMOND FILES UP TO 8 1/2"	260 MESH \$120.00
6"X5/8"X.032" \$ 22.00		360 MESH \$120.00
8"X5/8"X.032" \$ 26.50		600 MESH \$108.00
10"X5/8"X.032" \$ 36.00		AVAILABLE ONLY IN 6" X 11/2"
12"X5/8"X.040" \$ 57.00		20MM DIAMOND SLITTER \$2.00
14"X3/4"X.040" \$ 64.00		
16"X3/4"X.040" \$ 131.00		
18"X3/4"X.040" \$ 164.00		
20"X1"X.060" \$ 257.00		
DIAMOND CORE DRILLS 4MM TO 50MM	DIAMOND FLAT LAPS	DIAMOND DRILLS
DIAMOND POLISHING PASTE 5 GRAM SYRINGE \$5.95	MESH 6" 8"	ONE .75 MM
360, 600, 1200, 3000, 14000, 50000 MESH	1200 \$24.00 \$36.00	\$1.40 1 MM
	600 \$27.00 \$39.00	25 PACK 1.25 MM
	260 \$34.00 \$43.00	\$30.00 1.5 MM
	180 \$41.00 \$53.00	100 PACK 2 MM
	100 \$47.00 \$59.00	\$95.00 2.5 MM
	60 \$51.00 \$69.00	

WE ARE ONE OF THE FASTEST GROWING DIAMOND TOOL COMPANIES.
THERE HAS TO BE A REASON QUALITY LAPIDARY PRODUCTS AT DISCOUNT PRICES I
VISIT OUR WEB SITE AT WWW.LOPACKI.COM TO SEE OUR COMPLETE PRODUCT LINE

PR PrettyRock.com

Enter the Our

2010

**Faceting
Contest!**

see website for details



PR
PrettyRock.com



Chase away your
winter blues with

FREE Shipping*

1/1/10 to 3/31/10

Easy Gem ID
Interactive
Online
Database



Chat about
ROCKS
on our Forum

Free
Tutorials

704-299-2853

POB 38930 Charlotte NC 28278

*on domestic orders - some items excluded

FREE Gem Cloth

with any purchase!

Just put **JanCloth**

in message box at check out.

While Supplies Last. Valid until 2/15/2010

750,000 MINERAL SPECIMENS

100 TONS OF CUTTING ROUGH

• SLABS • LAPIDARY EQUIPMENT • FACETING ROUGH • FOSSILS • SOUVENIRS
• ROCKHOUND SUPPLIES • ARKANSAS QUARTZ • NEW FINDS OF DEMANTOID
GARNET, JEFFERY QUARRY, QUEBEC, CANADA • NEW FINDS FROM MOROCCO:
SPHAEROCOBLTITE ON COBALTOAN DOLOMITE, ARSENIOSIDERITE, DEVILLINE
IN SELENITE, AND HEMATITE STALACTITES

SHOW SCHEDULE 2009 - 2010

Tucson, Arizona - Room 128, InnSuites

January 30 - February 13, 2010

Raleigh, N. Carolina - Kerr Scott Building, State Fairground

April 9 - 11, 2010

Houston Fine Mineral Show,

Embassy Suites Hotel, Room 201, Houston Texas.

April 30 - May 2, 2010

Springfield, Massachusetts - Eastern States Exposition Center

August 13 - 15, 2010

Denver, Colorado - Holiday Inn North, Room 115

September 15 - 19, 2010

Detroit, Michigan - Gibraltar Trade Center
in Mt. Clemens (237 North River Road,
about 10 miles away from
our previous location), just off I-94 exit 237.

October 9 - 11, 2009

Houston, Texas - Humble Civic Center

November 13-15, 2009



**Wright's
ROCK SHOP, INC.**

3612 Albert Pike Dept. RG, Hot Springs, Ark. 71913

501-767-4800 Fax: 501-760-2390

Email: wrightsr@ipa.net

Webpage: www.wrightsrockshop.com

THE DENVER COLISEUM SHOW



**SEPTEMBER 15 - 19, 2010
(WEDNESDAY - SUNDAY)**

**MINERALS, FOSSILS, METEORITES,
CRYSTALS, GEMS, JEWELRY, GOLD**

A GREAT SHOW FOR BUYERS!

- **FREE** admission
- **FREE** parking for 2,000 cars
- **FREE** shuttle to the other nearby shows
- Space for 200 dealers + 200 more in parking lot tents
- A 5-day show attracts more dealers with larger selections

A GREAT SHOW FOR SELLERS!

- **JUMP-START** 4 days earlier on Saturday for tent dealers
- The most heavily promoted show of its kind in America
- The lowest cost table fee of all the Denver shows
- Excellent booth & tent locations still available
- Apply now! Call Christine at (516) 818-1228

WWW.COLISEUMSHOW.COM



QUALITY PRODUCTS FOR OVER THIRTY YEARS

- EOPOXY 220amber clear bonding
- EOPOXY 330water clear bonding
- TENAXinstant super glue
- TENAX + PLUSa thick instant adhesive
- OPTICON 224fracture sealer
- ATTACKepoxy solvent

AT YOUR DEALER

Hughes Associates

18116 Mtka. Blvd., Wayzata, MN 55391

phone: 952-404-2626 fax: 952-474-4636

Don't Miss Any of These Fine Shows

Westward Look Mineral Show
February 5-8, 2010

Houston Fine Mineral Show
April 30, May 1-2, 2010

San Francisco
Fine Mineral Show
July 9-11, 2010



Photograph by Jeff Scovil

Please
Join Our
Mailing List.

Visit www.FineMineralShow.com



Lapidary Supplies and Equipment

Most Orders Shipped within 24 Hours

Authorized Dealers of: Crystalite, Lapcraft, Covington, Inland, MK Diamond, Raytech, Diamond Pacific, Graves and more.

Order Toll Free (866) 929-8575
email: info@arrowheadlapidarysupply.com

Arrowhead Lapidary Supply

P. O. Box 247

Wellington, OH 44090

Call or write for FREE Catalog

Website: arrowheadlapidarysupply.com

FIELD TRIPS

FT: Judith Peak Black "Diamonds".....	Oct.
Colorado	
Octahedral Pyrite.....	Jun.
Michigan/Minnesota	
Lake Superior Agates.....	Jun.
Montana	
Montana's Jurassic Fossils.....	Apr.
New Mexico	
Gold Hill, New Mexico.....	Jan.
Tennessee	
The Burra Burra Mine.....	Jun.
Texas	
West Texas Agate.....	May
North Carolina	
Chunky Gal Corundum Hunt.....	Mar.
Idaho	
Rabbit Springs Geodes.....	May
Montana	
Bear Canyon Agate.....	Jul.
Oregon	
Bullards Beach Rockhounding.....	Aug.
South Carolina	
Black Water and Bones.....	Aug.
Texas	
Big Bend Country Bonanza.....	Nov.
Washington	
Washington Zeolites.....	Jun.
Puerto Rico	
Puerto Rico Serpentine.....	Sep.
Canada	
Bruce Mines Puddingstone.....	Feb.

PROJECTS

Make a Garden Stepping Stone.....	Jan.
Make a Sustainable Dolphin Cameo.....	Mar.
Make a Tumbled Stone Necklace.....	May
Make a Solderless Belt Buckle.....	Jun.
How to Make Solderless Mounts.....	Oct.

GOLD AND PROSPECTING

2009: A Gold Odyssey.....	Jan.
5 Ways to Improve Fine Gold Recovery.....	Jul.
In Pursuit of Liberty Gold.....	Jul.

ARTIST PROFILE

Randy and Kitsana Polk.....	Feb.
Lois Brandt Phillips.....	Aug.
The Rock Art of Al Troglin.....	Nov.
Flintknapper Randy Beach.....	Dec.

LAPIDARY

Lapidary 101: Cabochons.....	Apr.
In-a-Flash Opal Inlay.....	Oct.
How I Do It.....	Dec.

MINERALS IN DEPTH

Pseudomorphs.....	Feb.
Minerals and the Native Elements, Pt. 1.....	Mar.
Minerals and the Native Elements, Pt. 2.....	Apr.
What's In a Mineral Name?.....	Apr.
Remarkable Quartz.....	Aug.
Crystal Twins.....	Sep.
What's That in Your Agate?.....	Nov.

IMPORTANT MINERAL SOURCES

Arizona's Vanadinites.....	Mar.
Michigan Copper.....	May
Utah's Red Beryl.....	Jun.
The Rich Mineral Heritage of Tiger, Arizona.....	Jul.
Herkimer, New York, Quartz.....	Aug.
Arkansas Quartz.....	Sep.
Alaska's Epidotes.....	Oct.



MUSEUMS

The University of Arizona Mineral Museum.....	Jan.
"Set in Stone" at the Arizona State Museum.....	Dec.

COLLECTING

The Mines of Morocco.....	Jan.
Poland Mining Camps.....	Feb.
Guatemalan Jade.....	Apr.
A Basic Mineral Collection, part 1.....	May
Gemstones of the Beaches.....	May
A Basic Mineral Collection, part 2.....	Jun.
A Basic Mineral Collection, part 3.....	Jul.
Panning: It's Not Just for Gold.....	Jul.
The Forgotten Collectors.....	Aug.
Kentucky Agate.....	Nov.
Collecting "Old Classic" Minerals.....	Dec.

CHILDREN

Rock & Gem Kids.....	Jan.
Rock & Gem Kids.....	Feb.
Rock & Gem Kids.....	Mar.
Rock & Gem Kids.....	Apr.
Rock & Gem Kids.....	May
Rock & Gem Kids.....	Jun.
Rock & Gem Kids.....	Jul.
Rock & Gem Kids.....	Aug.
Rock & Gem Kids.....	Sep.
Rock & Gem Kids.....	Oct.
Rock & Gem Kids.....	Nov.
Rock & Gem Kids.....	Dec.

SUSTAINABILITY

"Green" Rockhounding.....	Mar.
Fair Trade: A Gem of an Idea.....	Mar.

MISCELLANEOUS

Three Centuries of Diamonds.....	Mar.
Mining Stocks.....	Apr.
Treasure Hunter: Kirsten Gum.....	Apr.
Urban Stalactites.....	Apr.
The Other Gem Zoisites.....	May
Moon Rocks and Minerals.....	Jun.
Framed Picture Stones.....	Jul.
I Fought the Law.....	Jul.
The Rock Food Table.....	Aug.
Adventures in Mineral Identification.....	Sep.
Colorado's Dinosaur Journey.....	Sep.
A Rockhound Tour of England.....	Oct.
A Lifetime of Agate.....	Nov.
A Tale of Four Agates.....	Nov.
Yale's Mineral Legacy.....	Dec.

To order back issues, send coupon and payment to:

Rock & Gem Back Issues

290 Maple Court, Suite 232, Ventura, CA 93003

\$10.00 for each issue, includes postage & handling. Or click the 'Search & Order Back Issues' button online at www.RocknGem.com. Supplies are limited. Back issues can also be purchased by credit card by calling (805) 644-3824 ext. 124.

Month/Yr _____	price \$ _____	NAME _____
Month/Yr _____	price \$ _____	STREET _____
Month/Yr _____	price \$ _____	CITY _____
Total Enclosed \$ _____		STATE _____ ZIP _____

44th
Annual

WHERE IT ALL BEGAN...

QUARTZSITE POW WOW GEM AND MINERAL SHOW AND RELATED HOBBIES



SPONSOR - QUARTZSITE IMPROVEMENT ASSOCIATION

-- FREE PARKING -- FREE ADMISSION --

JAN. 20 - JAN. 24, 2010 Wednesday thru Sunday
Field Trips Daily by Quartzsite Roadrunner Gem & Mineral Club
Food Served Daily Jan 19 - Jan 24, 2010
7 am-7 pm Cafeteria Style + Vendor Food Line

- NOTICE TO BUYERS -

Truly the buyers market of the world
Over 500 outdoor sites and 10,000 square foot building

Displays from
around the world

Dealers with gems

- Minerals -
- Jewelry -
- Beads -

Demonstrations

Wire wrap supplies
and Much More...

For Dealer Information write Show Chairman - QIA, P.O. Box 881, Quartzsite, AZ 85346-0881

Phone: (928) 927-6325

Fax: (928) 927-4503

E:Mail: powwow@qiaaz.org

Web Site: www.qiaaz.org

Sales Tax License Required by AZ Department of Revenue

Quartzsite Vendor Selling Permit Required - Purchase prior to show @ QIA

PORTABLE STAND WITH SIFTING SCREENS



• Portable • Sturdy • Durable •
1/4 " & 1/2" • Only 12 Pounds

Whether looking for gemstones, crystals, arrowheads,
fossils, seashells, or whatever, this is the tool to use.

Only \$120.00. Shipping free in USA.

Great South Gems & Minerals, Inc.

38 Bond Drive, Ellenwood, GA 30294

1-888-933-4367 www.greatsouth.net

Minerals Unlimited

Mineral & Rock Specimens
for Collectors, Teachers
& Research

Send \$2.00 for catalog or visit

www.mineralsunlimited.com

PO Box 877, Ridgecrest, CA 93556-0877 USA

Ph (760) 375-5279 Fax (760) 375-2300

email wendi@mineralsunlimited.com

CLASSIFIED

CLASSIFIED

CLASSIFIED

CLASSIFIED

ence appointment cash sales only 478 922 7200. gemmastercomet77@gmail.com bargains treasures rarities shipping extra. IB10

Indianapolis Area (Lawrence). Findings, supplies, minerals, fossils, equipment, rough and finished stones. No list. JOX ROX, 4825 N. Franklin Road, Indianapolis, IN 46226. Hours: 10:00 a.m. to 6:00 p.m., Monday through Saturday. (317) 542-8855. L10

Asheville, North Carolina: Area's premier showroom of minerals, jewelry, fossils, lapidary and rockhound equipment. Large selection of beads and jewelry-making supplies. SILVER ARMA DILLO INC., 40 Westgate Park way, Asheville, NC 28806. (828) 253-3020. Web site: www.silverarmadillo.com L10

Philadelphia / Delaware Valley. Come See The Largest Complete Rock Shop in the East. Gems, Minerals, Fossils, Equipment, Meteorites, Artifacts, Gifts, Custom Jewelry and Repairs. GARY'S GEM GARDEN. Sawmill Village Center, Route 70 (1 mile west of I-295), Cherry Hill, NJ 08034-2412. (856) 795-5077. Visit us at: garysgemgarden.com L10

Herb's Lapidary Shop — Route 1, Box 29, South 81 Hwy., Comanche, OK 73529. Southwest Oklahoma's largest! Tons of rough agate, fossils, onyx and finished product. Wednesday through Saturday, 9 a.m. to 6 p.m. (580) 439-4186 or (580) 439-5347. C10

Ellenwood (Atlanta), Georgia. Great South Gems & Minerals, Inc. Minerals, fossils, eggs, spheres, cutting material, tumblers & grits. Books. 38 Bond Drive, Ellenwood, GA 30294 (770) 507-7113 www.greatsouth.net CL10

Exeter, New Hampshire: Santerre's Stones 'n Stuff. Minerals, fossils, cabbing and faceting rough, carvings, beads, bead supplies, gemstones, jewelry, and gifts. 42 Water St., Exeter, NH 03833. (603) 773-9393 www.SanterresStones.com BA10

Austin, Texas: Tons of Rough Rock, carving and cabbing material starting at \$2 per pound. Huge crystals and minerals, fossils, meteorites, fluorescent rocks, rare crystals, mineral specimens, turquoise and natural stone jewelry/beads, equipment. Three locations catering to lapidary, collector and metaphysical needs. 1100 E. 5th St. (512) 472-5015. Open 7 days 10-6. ... 2307 Kramer Ln. (512) 833-7760. Open Mon.-Sat. 10-6. ... 4300 S. IH35 Georgetown. (512) 864-7319. Open Mon.-Fri. 10-6. L10

Montrose, Colorado: That-Little-Shop Worldwide selection of minerals and fossils, plus a full line of beads and a gift shop. 17656 Hwy. 550 South of Montrose. 16years. (970) 240-8527. Closed on Mondays. FE10

Rolla, Missouri. Crystals, minerals, fossils, beads, cabochons, beading supplies, lapidary supplies, rough rock, geodes, findings, etc. Ray's Rocks and Gifts and Missouri Mineral and Bead now located at 1019 Kings highway, Ste. 3, Rolla, MO. Just 5 minutes from I-44, exit 184. (573) 426-2744. www.mmabllc.com 1009

ROUGH FOR CABBBING
CACOXENITE IN AMETHYST. Very old Brazilian material from the 1960's. Tumbling

material in 2 sizes, tumbled material in 2 sizes, and cabbing material in 2 sizes. Email cacoxenitelady@hotmail.com for pictures and prices or mail to: Maggie Alderson, P.O. Box 27586, Scottsdale, AZ. 85255 for pricing info. KA10

Gold Sheen Obsidian. Honey, brown and green; honey, brown and red; orange, green and blue Calcite all from Mexico. \$5.00 per pound or 50 pounds for \$200.00 plus shipping. (978) 745-5255 IB10

Turquoise: Many varieties natural and stabilized all price ranges. Also available: cabochons, fire agate, lapis, opal, wildhorse and facet rough. Oro Valley Gems. 9755 N. Calle Buena Vista, Oro Valley, AZ (520) 544-0741. www.orovalleygems.com L10

Idaho Willow Creek Jasper Rough. \$20.00 per lb., plus postage. No shop. For more info, write LARRY'S ROCK & GEMS, 5810 S. Bogart Lane, Boise, ID 83714. J10

Montana Agate Special: 25-pound-plus box, jewelry quality, no clears. \$175 Free shipping in USA. Bob Gwin, P.O. Box 806, Terry, MT 59349, (406) 635-4036. rock@midrivers.com BA10

Beautiful Wyoming Jadite "Jade" medium green and dark green. \$15 per lb. Jon, Cheyenne, Wyoming. (307) 632-0889. HK09

Slabs, rocks, boulders; Huge inventory including exotics; see website lists; Hwy 50-95 Rock Shop, 4261 Reno Hwy, Fallon, NV 89406; (775) 867-2144; www.fallonrockshop.com CB10

ROUGH FOR FACETING

Free Catalog. The largest and most competitive selection facet or cabochon rough in the industry. "The Source." KNIGHT'S HOUSE OF FINE GEMS, Box 411, Waitsfield, VT 05673. (802) 496-3707. E-mail: knights@mdriver.com L10

SERVICES

Lambert Industries, Americans in Bangkok! Superior faceting: \$1.20 per finished carat for most stones, corundum \$2.50 per finished carat, less if smaller. Cabbing is cheaper. Deal with English, German speaking professionals. Skilled Thai cutters, reliable American/Swiss management. Lambert Industries, 807-809 Silom Road, Bangkok 10500, Thailand. Phone (66)2 236 4343. Email Lambertind@gmail.com Web site: www.lambertgems.com ED10

SPHERES

Spherefactor: Your Gemstone and Mineral Sphere Store: Sugillite, Emerald, Ruby, Sapphire, Tourmaline, Lapis, Opal, Marcasite, Turquoise, Aquamarine, Kyanite, Llanoite, Lodolite Quartz, American Jasper, Jade, Coprolite, Dinosaur, Metaphysical, Australia, Russian, SO MUCH MORE! www.spherefactor.com. E-bay store: SPHERE FACTOR. (210) 257-6070. L10

WANTED TO BUY

Offering \$300 for one clean hardcover (English) copy of Zenz's first book *Agates* for a first year private collector. Erik Andersen, 215 Pembroke Road, Naperville, IL 60540. K9EU@att.net A10

Now you can reach THOUSANDS of READERS WORLDWIDE who want to buy and sell.

1. Write Your Ad On a separate piece of paper, print or type your ad with a minimum of 25 words. Each word, abbreviation or initial counts as one word. Rates are as follows:

n o. of Issues	Rates (per issue)
12 (1 year)	.90 per word
6-11	1.00 per word
1	1.10 per word

All-bold type with frame: Add \$15.00 per issue.
Regular type, frame and color: Add \$20.00 per issue.

2. Choose A Category Use the following list to determine under which classification you would like your ad to run:

- | | | |
|---|---|---|
| <input type="checkbox"/> Auction | <input type="checkbox"/> Jewelry & supplies | <input type="checkbox"/> Rock shops |
| <input type="checkbox"/> Beads & supplies | <input type="checkbox"/> Lapidary equipment | <input type="checkbox"/> Rough For Cabbing |
| <input type="checkbox"/> Books & Videos | <input type="checkbox"/> Lapidary supplies | <input type="checkbox"/> Rough For Faceting |
| <input type="checkbox"/> Business Opportunities | <input type="checkbox"/> Minerals | <input type="checkbox"/> Rough For Tumbling |
| <input type="checkbox"/> Cabochons | <input type="checkbox"/> Miscellaneous | <input type="checkbox"/> services |
| <input type="checkbox"/> Catalogs | <input type="checkbox"/> nuggets | <input type="checkbox"/> Wanted to Buy |
| <input type="checkbox"/> Fossils | <input type="checkbox"/> Opals | <input type="checkbox"/> Other |
| <input type="checkbox"/> Finished Gems | <input type="checkbox"/> Preforms & slabs | |
| <input type="checkbox"/> Geological Instruments | <input type="checkbox"/> Prospecting | |

3. Choose Number of Insertions

Decide how many issues you want your ad to run in, and when you want your ad to start and stop. Deadlines for ad copy are as follows:

Issue:	Ads In By:
March	January 15
April	February 15
May	March 15
June	April 15
July	May 15
August	June 15

Please email your ad along with the following information to: ads4miller@millermags.com All late ads received after the deadline date will be used in the next issue.

4. Fill Out The Form
ALL Ads Mus T Be PAID In FuLL, In Ad VAnCe.
(Minimum charge of 25 words per ad, per issue.)
Submit your ad and credit card payment to:
ads4miller@millermags.com
Subject line:
ROCK & GEM CLASSIFIEDS
If you are not paying with a credit card, you may mail your order form, ad and payment to:
Rock & Gem Classifieds
290 Maple Court, Suite 232, Ventura, CA 93003
Fax: (805) 644-3875 Phone: (805) 644-3824 ext.127

Company Name _____ Contact Name _____
Address _____
City _____ State _____ Zip _____
Phone _____ E-mail _____
Category Heading _____ Number of Words _____ Cents per Word _____
Number of Issues _____ Beginning with the _____ issue. Boxed: Yes NO
Total Enclosed _____ Check (payable to Rock & Gem) MC Visa Color Highlight: Yes NO
(Minimum charge of 25 words per ad, per issue.)
Account Number _____ CW# _____ Exp. Date _____
(last 3 digits of code on back of card)
Signature _____

Index to Advertisers

Rock & Gem Customer Service

Ackley's Rocks	14	Lapcraft, Inc.	59, 64
Amateur Geologist	25, 45	Lasco Diamond Products	31
Arrowhead Lapidary & Supply	72	Lehigh Mineral Auction	49
Au-Rus Wax Patterns	64	Daniel Lopacki Co.	70
AZ Timeless Treasures	49	Lortone, Inc.	61
B&J Enterprise/Joyce Emerson	64	Lot-o-Tumbler	49
B&L Minerals	49	MP Products, LLC	37
Badger Sintered Tools	18	Majestic Press, Inc.	48
Barranca Diamond	53, 67	Marshall Lapidary Engineering	49
Beautiful Agates	49	MarZee Lapidary Tutorial DVDs	64
John Betts — Fine Minerals	67	Metalliferous	67
Bezel Form	14	The Mineral Gallery	49, 64
C&C Minerals	49	Mineral of the Month Club	61
CFC Jewelry Supplies	15	Mineralab	60
Cal State Gem Mine	49	Mineralman	49
Capistrano Mining	49	Minerals Unlimited	73
CarTopCamper.com	64	Miner's Keepers	52
J S Copti	65	Minertown	49
Covington Engineering	55, 77	Minnesota Lapidary Supply Corp.	30, 66
Craftstones	52	Mississippi Gem & Mineral Society	15
Crizmac Travel Adventures	26	Nature's Outback	49
Crystal Cave	65	New Era Gems	36
Crystal Grove	49	North Coast Faceting	64
Cuesta Fire Agate	65	Northwest Distributors	62
Deepak Gems	49	Oakrocks.net	49
The Denver Coliseum Mineral, Fossil, Gem & Jewelry Show	71	On the Rocks Gems, Jewelry & More, Inc.	44, 65
Desert Gardens Gem Show	63	Optima Gem	36
Diamond Pacific Tool Corp.	65, C3	Oxy Rocks	64
Dragonsaye Auctions	49, 65	Phoenix Orion Gifts	49
Earthworks	24	Pickens Minerals	64
Easy Steps Video	18	Pioneer Gem Corp.	60
Ebersole Lapidary Supply, Inc.	39	Polaris Tool & Machine	69
Bill Egleston	45	Pretty Rock	65, 71
Eloxite Corp.	77	Quartzsite PowWow	73
Facet Shoppe	24	Raytech Industries	16-17
Fac-Ette Manufacturing, Inc.	40, C4	Blaine Reed	64
Fine Mineral Show	64, 72	Research Unlimited	64
Fire Mountain Gems	9, 65	Richardson's Rock Ranch	49
The Foothills, Inc.	26	Rob's Rock Shop	49
John E. Garson Gems & Minerals	45	Rockaway Opals	49
Gem & Lapidary Wholesalers, Inc.	10, 41, 46, 69	The Rock Peddler	44
Gem Center USA Inc.	53	Rocks & Minerals	49
Gem Faire, Inc.	20	Ross Metals	3, 5, 82
Gem-Fare	30	Sapphire Mining	49
The Gem Shop	49	Shipwreck Beads	81
Gemological Institute of America	49	Spencer Opal Mines	58
The Geode Gallery	14	South Pacific Wholesale Co.	62
Geological Wonders	49	Joseph P. Stachura Co., Inc	24
Georgia Rock Shop	30	Steve's Rocks & Gifts	48
Gilman's	32	Stuart's Minerals	49
Goldmaps	65	Super Agates	49
Great South Gem & Minerals, Inc.	73	Sylmar Displays	66
William Holland School of Lapidary Arts	58	TEP Gem Show, Inc.	47
Houston Fine Mineral Show	27	TFG Collector	26
Hughes Associates	72	Tagit	62
In A Flash Opal Inlay	63	Treasure Chest	44
Inland Lapidary	38, 58, 70	Tru-Square Metal Products	63
Imperial Manufacturing	64	Tucson Electric Park RV Gem Show	21
JS Gems Lapidary	40, 65	Tucson Gem & Mineral Show	33
Jarvi Tool Co.	60	Tyson Wells	55, 81
Jeanne's Rock & Jewelry	65	U.S. Geological Supply	25
Jesco Products, Inc.	18	Ultra Tec	C2
Katy Rock Shop	49	Unique Tool	32
Kingsley North, Inc.	7, 15	The Universe Collection	66
Kino Rocks & Minerals	64	VR Gem Cutters	38
Klamath Rock Club	59	The Village Smithy Opals, Inc.	19
Knight's	64	Whittmore Durgin Glass Co.	36
Kristalle	49, 60	Wright's Rock Shop	49, 71
Lamberton Rake	32	Martin Zinn Expositions, LLC	11

TO ORDER A SUBSCRIPTION:

For faster service, subscribe online using our secure server at www.rockngem.com, or send a check or money order for \$24.00 for 12 monthly issues to Rock & Gem, P.O. Box 469112, Escondido, CA 92046-9524.

WHAT TO DO IF YOU HAVE PAID FOR YOUR SUBSCRIPTION BUT STILL RECEIVE A BILL:

The check and the invoice may have crossed in the mail. You can check your order online at www.rockngem.com. It may take up to four weeks to process your check, so if you wrote the check less than four weeks ago, disregard the bill you received. If you paid for your subscription more than four weeks before you received another bill, send a copy of your cancelled check along with your bill to Rock & Gem, P.O. Box 469112, Escondido, CA 92046-9524.

TO SOLVE A SUBSCRIPTION PROBLEM:

You can check the status of your subscription online at www.rockngem.com. Remember, it may take up to eight weeks to change an address and 6-8 weeks to start a new subscription. Please give us time to get your magazine to you, and if it still doesn't arrive, please e-mail us at rockngem@pcspublink.com or call 1-760-291-1549. If your subscription has already started, or you receive a damaged copy, please email us, and we will send you a replacement copy.

RENEWALS:

It can take up to 6-8 weeks to process your renewal, so don't wait! Renew early so you don't miss an issue. You can renew online at www.rockngem.com using the Inet number listed on the address label of your magazine, or just return the renewal form with your check or money order. Please do not send cash! If you renew your subscription before your expiration date, we'll add on the new issues at the beginning of your expiration issue. You won't lose any issues by renewing early, and you'll guarantee you won't miss any!

TO GET ANOTHER COPY OF THE ISSUE:

Additional copies are available at the newsstand, or you may order them online at www.rockngem.com.

BACK ISSUES:

Back issues are available online at www.rockngem.com.

MOVING?

You can change your address online at www.rockngem.com using the Inet number listed on your magazine label, or call 1-760-291-1549. It can take 6-8 weeks to get an address change processed, so make sure you contact your local post office and ask them to forward all of your mail.

HOW TO PLACE AN AD IN Rock & Gem:

Please contact Brian Roberts via email at broberts@jmillermmedia.com or call him at 623-327-3525.

HOW TO SELL Rock & Gem IN YOUR STORE:

Please contact us at ttrimbach@jmillermmedia.com or call 805-644-3824 Ext. 120.

VISIT US AT www.rockngem.com.

IT'S THE MOTHER LODE!



BELOW LIST PRICES on Rockhound Supplies, Lapidary Equipment, Beads & Beading Supplies & Much More!

FAST SERVICE!

Eloxite Corp.

"Your complete jewelry craft & lapidary supply house!"

Write or call for your **FREE CATALOG** with **LOW, LOW, BELOW LIST PRICES** on: Beads & Beading Supplies, Cabochons, Faceted Stones, Many Gemstone Items, Rockhound Tools, Lapidary Equipment, Polishes, Findings Galore, Earrings, Bracelets, Chains, Charms, Leather Belts, Pendants, Money Clips, Sterling Silver Items, Feathers, Rings, Bola Slides, Bola Ties, Belt Buckles, Buckle Inserts, Jeweler's Tools & Supplies, Clock Movements, Jewelry Boxes, Diamond Tools & Saw Blades, and much, much, more! (Quantity Discounts Available)

WE'RE ON THE INTERNET!
Visit our On-Line Store at www.eloxite.com



Call, write, or fax for your FREE 122 PAGE CATALOG FULL OF OVER 2000 items at Below List Prices.

PHONE (307) 322-3050
FAX 3073223055, or write:
Eloxite Corp.
Dept. 5; P.O. Box 729
Wheatland, WY 82201

CALL BEFORE NOON MOUNTAIN TIME AND YOUR FREE CATALOG WILL BE ON THE WAY THE SAME DAY!

Now You Can Read ROCK & GEM Online!

Just click and read – no download or software required.

*Same great magazine plus **HOT LINKS** and more!*



You'll get the exact issue you'd receive in the mail while saving resources and reducing our environmental footprint. Our digital magazines feature live links in every issue, permanent access to your electronic back issues, and the freedom to print only what you need – all in an easy-to-use format.

Traditional print magazine subscriptions also available.

www.rockngem.com



Now Manufactures Rocipro Lap.



Proudly Built in the USA

- * Available in 20", 24" 30", & 36" Models.
- * Heavy Duty Sealed Ball Bearings.
- * Heavy Cast Iron Base and Lap Plate, with Splash Guard.
- * Heavy Duty 110v 1/3 Hp Motor, & Now Available in *220v 50hz for Export.



FOR FREE CATALOG OR DETAILS

Covington Engineering **CALL US TOLL FREE (877) 793-6636**
P.O. Box 35 - 715 West Colton Ave. Outside U.S. (909) 793-6636
Redlands, CA 92373 **FAX (909) 793-7641**

e-mail us at sales@covington-engineering.com

On Line @ www.rociprolap.com or www.covington-engineering.com

Winter Shows

The winter season in the American Southwest is always exciting for mineral collectors. The huge Quartzsite, Arizona, event offers enough variety to please any rockhound. The Quartzsite Improvement Association (QIA) hosts its annual Pow-Wow at the end of January. This local organization is responsible for starting a mineral show at Quartzsite to raise money for a local medical clinic and fire truck. Little did its members realize that their effort would grow into this country's biggest desert happening.

Before, during and after the Pow-Wow, the QIA offers a variety of club activities throughout the winter. You can play bingo or cards, attend dinners, go on field trips, have fun at sponsored dances, feast at potluck suppers and enjoy a host of other events the organization offers. This helps make wintering in Quartzsite a real joy and attracts more and more northerners to Arizona's delightful winter climate. The town has a summer population of perhaps 1,200 folks, but it booms into a bustling winter city of maybe 250,000 in the winter.

The Quartzsite Gem & Mineral Club (QGMC) is also very active, boasting more than 1,000 members. This club is really well equipped for the lapidary, with a fine workshop that is open all winter. Nearby is perhaps the finest faceting facility in the United States, and the club hosts lots of field trips in the open area that surrounds this desert town. Anyone who is a member of this club will never lack for exciting and interesting things to do while in Quartzsite.

Last year, *Rock & Gem* decide to host a field trip during the QIA Pow-Wow. We joined forces with the QGMC, and 50 folks had a great time collecting hematite and red jasper lapidary material. Everyone had fun and found good material. A couple of fellows, aided by *Rock & Gem's* big sledge, even broke up a huge red-and-black boulder. They shared their wealth with others, so everyone went away happy!

This year, *Rock & Gem* and the QRMC will once again offer a field trip during the



We found some nice jasper/hematite cutting rough on the 2009 field trip in Quartzsite, Arizona.

QIA Pow-Wow, with yours truly acting as host and guide. The date is Saturday, Jan. 23, 2010. The field trip location has yet to be determined, but you can count on having a good time. We might check out the hematite/jasper locality again. It was certainly fruitful last year!

One of my favorite shows takes place Jan. 8-10 in Mesa, Arizona, in the Mesa Community College (MCC) parking area. Sponsored by the Arizona Mineral and Mining Museum Foundation and known for years as "the Flagg Show", this open-air tailgate show has grown from a weekend gathering of two or three dozen local collectors into a huge outdoor event with more than 100 dealers. The beauty of this event is that collectors from all over the state of Arizona become weekend dealers and sell what they have collected during the past year. You can find real bargains and unusual things you simply won't see at the big, formal, high-priced shows!

For the first time, this tailgate show will be operating under some necessary guidelines. So many people have been coming to sell their goods that the show has become somewhat chaotic, especially during the days prior to setup. The Foundation has therefore established some guidelines, primarily to control where and when folks set up to sell.

In the past, anyone could show up during the days before the show and set up, camp on site for a couple of days, and sell during the weekend show. This has really created

some animosity among those folks who work all week and can't get this jump start! It also creates problems for the Foundation, as folks camp on the MCC parking area without permission.

Another big problem is folks who travel in RVs or huge motorhomes, some with a car in tow. Such rigs consume anywhere from six to 10 parking spaces, preventing other dealers from having a space, and that's not fair. Now, the big rigs will have to be left in the parking lot and not brought into the show area.

Compounding that problem was the fact that the RVs didn't have to pay for all the space they consumed. In an extreme example, an RV would park in a bunch of dealer spaces along one parking lane, but then set up to sell in the neighboring parking lane, effectively hogging a dozen or more spaces! That will no longer be allowed to happen.

Whatever spaces are being used—one or a dozen—each dealer will now have to pay for *all* the spaces they occupy. After all, the Foundation, which is a nonprofit organization and supports the state museum, loses money when one dealer parks in a dozen spaces and only pays for one or two.

Another problem in the past has been dealers who are arriving earlier and earlier. Setup for the Friday through Sunday show is on Thursday, but people—especially out-of-towners with campers and RVs—arrive on Wednesday or even Tuesday. They simply park wherever, consuming sales spaces and causing dealers who arrive on setup day to be very upset. The show area will now be closed off until setup day, Thursday.

At any show, dealers who regularly participate prefer to have the same space each year so folks can find them easily. If an early arrival occupies a space in which a regular dealer normally sets up, you can guess what happens. It leads to ill feelings—or worse! To prevent early arrival and setup, the Foundation will have the entire parking area closed off, only opening it up on setup day. College security folks will help enforce this.

Once setup day arrives, those who have sent in their prepaid applications for space will be allowed in first to choose from assigned, marked spaces, and they will be required to pay for all the spaces they use. They will not be allowed to park personal vehicles in the sales areas. There is plenty of free parking in the lots that surround the sales area. Latecomers will get whatever spaces are available after the early applicants have parked. Obviously, it is to your advantage to apply for space early!

This outdoor show has become a huge success and is an important local event for collectors and dealers. It is hoped that these simple changes will keep things controlled, while satisfying all who support the Foundation's fundraising efforts. By and large, those dealers who come to the Flagg Show are helpful and cooperative. There are just a few folks who get a bit greedy.

The Foundation's goal is to give collectors and dealers a venue that is not too restrictive or costly, in contrast to many shows that are held indoors. When someone flouts the rules of common courtesy, however, the Foundation is forced to act. We look forward to everyone who enjoys the Flagg Show being willing to help us implement these few, but very necessary, changes in procedure.

DIAMONDS

Diamonds are back in the news. My friend Michael Leybov, with whom I worked on the video "Russian Gem Treasures", gave me a copy of his *Mineralogical Almanac* Vol. 14, Issue 3 titled "Mineral Observer: Mineral News from Russia and Beyond" (see the review in *Picks & Pans*, page 48). This particular issue, to which Michael supplied many photographs, has a wonderful article on the major diamonds that come from Siberia as well as several historically famous diamonds housed in the Almazny Fund, the Diamond Fund of the State Diamond and Jewelry Reserve in the Kremlin. The Almazny Fund is a remarkable museum that has quantities of uncut diamonds, large gold nuggets, impressive platinum nuggets, and much more on display.

Issue 3 features some of the more famous diamonds in Russian possession, including the Orlov and the Shah. The Orlov diamond, mounted in the Imperial Scepter, weighs nearly 190 carats. Count



The Jan. 9-10, 2010 Flagg Show in Mesa, Arizona, will draw big crowds and tailgating dealers once again!

Orlov bought this diamond for Catherine the Great in hopes of getting back into her good graces. It didn't work.

Collectors may have heard of the famous Fersmann Mineral Museum, which is housed in a building in Gorky Park, Moscow. Gorky Park was the estate of Count Orlov, and the museum building was the count's horse training facility at one time.

The Shah diamond is inscribed in Arabic, one of the few diamonds inscribed in that



This model shows the 3,106-carat Cullinan diamond and the two largest gems cut from it.

language. It is an oblong stone that weighs over 88 carats. It got its name because it was once owned by Shah Jahan of India, the builder of the Taj Mahal.

Both the Orlov and the Shah diamonds originated in the great mines of India, which were the source of many huge diamonds, including the Koh-i-noor, which now resides in England.

Of course, the largest diamond ever found was the Cullinan, a 3,106-carat gem that was eventually gifted to the British crown. That stone was cut into several major gems, which are part of the Royal Regalia now in the Tower of London. The Mineral Tour of England that I will be leading May 4-14, 2010 will stop at the Tower as part of our London excursion, and participants will get the chance to see these royal gems.

In September 2009, a new and very large diamond was found in the Cullinan Mine,

the same diamond mine that produced the Cullinan over 100 years ago. This new find is a clear gem of fine color that weighs in at 507.55 carats (more than 100 grams). It is the size of a chicken egg, which is huge by today's standard. I have to wonder whether this latest large stone was dug out

of the mine tunnel wall with a penknife, just as the Cullinan was back in 1906.

2010 TOUR

The 2010 Mineral Tour of England is now pretty well set. We get together in London on May 4 for an 11-day tour that will take us through the museums of London, then on to Chatsworth House in Derbyshire, England's most gorgeous stately home. There we will see a marvelous mineral collection that was recently re-discovered, then enjoy lunch in the stunningly elegant mansion.

From there, we're off to the Blue John fluorite mine to go underground, then do a bit of mineral collecting in the area before heading to Cheddar Gorge and Cornwall. We'll spend four days in Cornwall, going underground, viewing collections, and digging a little green serpentine.

We'll finish Cornwall by seeing a "secret" collection in a castle, where the Lord of the Manor will host us for lunch! A brief stop at Stonehenge will bring us back to London, from whence we will head home on the May 14. Anyone who chooses to stay can

join me at the British Museum to see some historically important things: the Rosetta Stone and the Elgin Marbles. We'll also enjoy seeing the famous quartz skull. Some believe this full-size skull, carved from a single quartz crystal, came from the Lost Continent of Atlantis!

If you have not already signed up for the trip, contact CRIZMAC at (800) 913-8555 or visit www.crizmac.com. We'll see some amazing minerals and learn about the history of mining in Cornwall, England. 

Bob Jones holds the Carnegie Mineralogical Award, is a member of the Rockhound Hall of Fame, and has been writing for *Rock & Gem* since its inception. He lectures about minerals, and has written several books and video scripts.



Field Notes submissions are subject to editing. Address questions to "Editor" for a private response or to "Readers" and provide the contact information you'd like published. Send to Field Notes, *Rock & Gem* magazine, 290 Maple Ct., Ste. 232, Ventura, CA 93003.



RICK BEEHLER PHOTO

A Rewarding Friendship

I have been an on-again, off-again rock collector since I grabbed my first leaverite. This year, I finally got involved with the Mount Hood Rock Club and was lucky enough to become friends with Lamar and Merlia Tilgner.

At our last meeting, club president Stephan Petkovsek presented Lamar and Merlia with the American Federation of Mineralogical Societies' Rockhound of the Year award. A new member, Holly, who had learned to wire wrap in a workshop put on by the Tilgners, showed off her first wirewrapped stone.

What I have seen in both of them makes me wonder how many times they have or should have won this award for Rockhound of the Year. They are always open to questions and readily nurturing new people in our hobby. I think enough of their participation in the teachings of others and nurturing of new rockhounds to pass on this photo as a token of my appreciation for the mark they have made on my life.

—Rick Beehler
Vancouver, WA

England Tour

I had to write this as a thank you, not only for the wonderful publication that *Rock & Gem* is, but for the many wonderful articles and images it has contained over the years I have had the good fortune to read it.

I today received the October 2009 issue and was most interested in reading "A Rockhound Tour of England", by Bob Jones. It may seem crazy that a person living in England would consider this a very important article. Let me explain.

I live on the Isle of Wight, known as "Dino Island" due to the abundance of fossilized bones in the cliffs on the south end of the island, together with lignite, sandstone, ironstone, flint and limestone.

In my past, I used to visit such places as to be covered by the CRIZMAC tour 2010, but in those days I did not take much notice of the minerals available at such cheap prices. Today, those sites are all but gone. I hope in 2010 that I might also retrace some of those areas and see if I can find any samples for myself.

I wish all Americans and other internationals a wonderful trip.

—Roy Richardson
Isle of Wight, UK

For more information on the tour, download a .pdf brochure at www.crizmac.com.

—Editor

Green Monster Update

I enjoyed Bob Jones' October 2009 article "Alaska's Epidotes" very much! He quickly established that Alaskan epidote is remarkable and is synonymous with two localities, Copper and Green Monster mountains on Prince of Wales Island. Both localities are associated with the same contact metamorphic assemblage, so they are closely related by geology and proximity. He portrays the challenges of field collecting in one of Alaska's more remote regions very well. I especially appreciated learning more about Virgil Gile and Lee Myers, two dedicated and successful collectors who preceded Tom Hanna's and my tenure on Green Monster Mountain.

Since Bob's article appeared in *Rock & Gem*, I've gotten several inquiries as to whether Tom and I have removed any restrictions on allowing others to collect on Green Monster Mountain. We have not, nor do we enter into lease arrangements. Tom and I formed a partnership in 1980 when we purchased the patented Green Monster claims from Eskil Anderson of Spokane, Washington. Because the price was pretty darn high, and because of the locality's inherent dangers, we agreed that we had to close the mountain to other collectors. We were reluctant to do this, but we needed to protect our investment in the locality's mineral specimens. Fine epidote specimens are an especially rare and precious resource, even from this venerable locality, and we could not accept the possibility of their being taken by unknown people. We also recognize our responsibility to protect people, including trespassers, from Green Monster, and we realize the need to protect ourselves from possible lawsuits.

Bob mentions a couple of excellent references on these localities. For additional reading, I recommend Arthur Montgomery's "The Epidote Localities of Prince of Wales Island, Alaska" (*Rocks and Minerals*, Vol. 12, 1937), an account of Montgomery and Ed Over's famous 1935 expedition to these localities; "Famous Mineral Localities: Prince of Wales Island, Alaska", by Peter Leaven and Dick Thomssen (*The Mineralogical Record*, Vol. 8, 1977), an account of the Smithsonian-sponsored 1967 expedition, of which I was a member; Patricia Roppel's *Fortunes from the Earth: A History of the Base and Industrial Minerals of Southeastern Alaska* (Sunflower University Press, 1991); and my article "Famous Mineral Localities: Green Monster Mountain, Prince of Wales Island, Alaska" (*The Mineralogical Record*, Vol. 35, 2004).

—Douglas Toland
Sagle, ID

Map Correction

In the article "Big Bend Country Bonanza" (November 2009), the location of Marathon on the Texas map (page 57) is about 500 miles to the southeast of where it should be. The Big Bend is the small southern dip in the state map outline, not the southernmost tip on the Gulf of Mexico. The Stillwell Ranch is found near Marathon in what we call West Texas—Big Bend Country.

—Georgia Morgan Wedin
via e-mail

I apologize for the mistake. Here is the corrected map.

—Editor





TYSON WELLS

Arizona's Largest Winter Attraction!



TYSON WELLS

Rock-Gem-Mineral Show

Quartzsite, Arizona

JAN. 1 - 10, 2010

A 10-DAY SHOW

- Gems • Rocks • Minerals • Jewelry •
- Silver & Goldsmithing • Faceting •
- Precious Metals •

Lapidary Tools, Equipment & Supplies

FREE ADMISSION • **FREE PARKING**
 LOCATION AND DETAILS: S.W. Corner of I-10 Freeway and Highway 95, Quartzsite, Arizona, home of the largest show of its kind. • Takes days to see it all. • A buyers' and sellers' market of the world. • Smooth, fine graveled, dust controlled, packed surface for selling, parking and camping in the beautiful desert setting of Arizona's La Posa Valley. • Live on your show spaces or in our on-premises no-hookup campground with water and dump station. • Honey wagon available. • Easy access in and out of show. • Over 850 selling spaces on 25 acres. • This is a must see event.

TYSON WELLS 31st ANNUAL

SELL-A-RAMA Rock-Gems-Arts-Crafts Show

JAN. 15 - 24, 2010, A 10-DAY SHOW

A 25-ACRE OUTDOOR SPECTACULAR

An Unbelievable Variety Displayed on 2.2 Miles of Aisle Frontage

- Gems • Rocks • Minerals • Arts •
- Crafts • hobbies • Jewelry •
- Silver & Goldsmithing • Faceting •
- Precious Metals • Antiques • Coins •

TYSON WELLS

P.O. Box 60, Quartzsite, AZ 85346

Show Office Phone: (928) 927-6364 • For R.V. Office: (928) 927-6365

E-mail: tysonwells@tds.net

www.tysonwells.com

We will
BEAT any
 advertised
 price
ANYTIME
 on Czech
 Fire Polished
 beads*

SHIPWRECK
BEADS
 The World's Largest Selection!

*Visit our
 website
 for full
 details and
 information!

Open 9am
 to 6pm
 7 days
 a week!

Visit our showroom for wholesale or retail!

Sales (800)950-4232 Info (360)754-2323

8560 Commerce Pl Dr NE Dept RG Lacey, Wa 98516

www.shipwreckbeads.com



FABRICATORS AND SUPPLIERS

CHAINS • MILL PRODUCTS

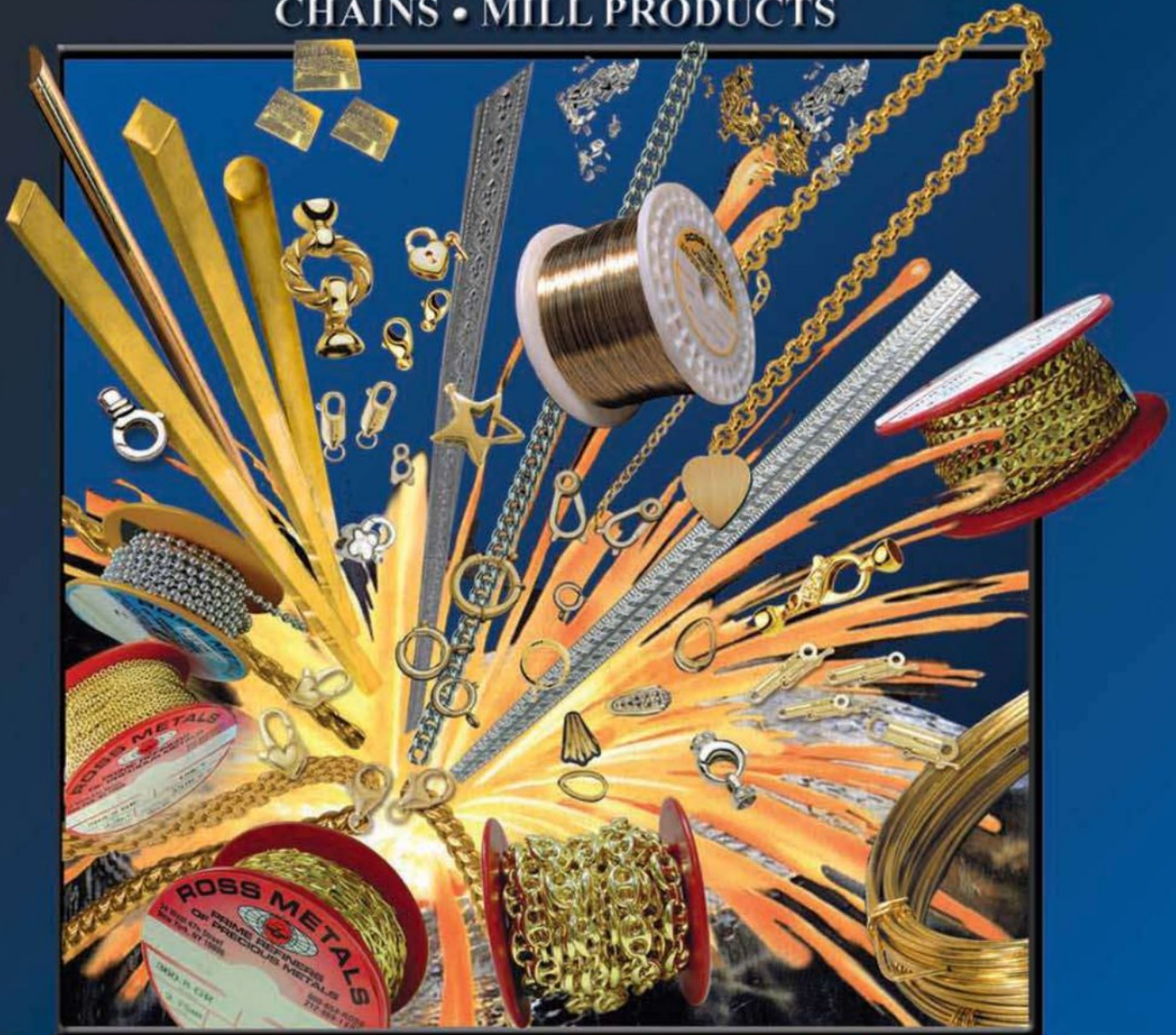

We stock the most comprehensive collection of precious metals mill products such as wire, plate, solder and grain/alloys. We also carry a grand assortment of spooled chain and finding accessories. Experience the variety and low prices of our superior products and service.



PLATE // CHOPPED SOLDER



ROUND WIRE / TUBING



WIRE SHAPES



PATTERN WIRE / PLATE



FANCY WIRES

GOLD

SILVER

PLATINUM

54 WEST 47TH STREET, NEW YORK, NY 10036
(212)869-1407 • (800)654-7677 • Fax (212)768-3018
www.rossmetals.com • sales@rossmetals.com



SAME DAY SHIPPING



CATALOGS AVAILABLE

You get top performance versatility and convenience with the Pixie all-diamond grinding and polishing machine.



Contact us for more information
or to request a **FREE** catalog.

Toll Free (800) 253-2954

(760) 255-1030

Fax (760) 255-1077

e-mail: diamondpacific@aol.com

2620 W Main St. Barstow, CA 92311

DIAMOND PACIFIC
TOOL CORPORATION

GemMaster II



Visit us at the
Tucson
Electric Park Show
Booth P-68



Fac-ette[®]
MANUFACTURING, INC.

www.fac-ette.com



9545 Ploof Road, Leland, NC 28451 • 910.371.3776 • 800.336.9248