

Flow visualisation

The flow of air cannot be seen by the naked eye. The flow of water can be seen but not its streamlines or velocity distribution. The consolidated science which analyses the behaviour of fluid invisible to the eye like this as image information is called 'flow visualisation', and it is extremely useful for clarifying fluid phenomena. The saying 'seeing is believing' most aptly expresses the importance of flow visualisation. Analytical studies clarifying hitherto unclear flows and the developmental studies of flows in and around machinery have been much assisted by this science.

About a century ago, Reynolds made the great discovery of the law of similarity by visualisation. Thereafter, Prandtl's concept of the boundary layer and his ideas for its control, Kármán's clarification of his vortex street, Kline's discovery of the bursting phenomenon allied to developing the mechanism of turbulence, and other major discoveries concerned with fluid phenomena were mostly achieved by flow visualisation. Furthermore, in the clarification of turbulent structure, the establishment of mathematical models of turbulence, etc., which currently still pose big problems, flow visualisation is furnishing extremely important information

In recent years, with the progress of computers, its use has been enhanced by image processing. Also, computer-aided flow visualisation (CAFV), the image presentation of numerical computations and measured results, is making great advances.

16.1 Classification of techniques

The visualisation techniques are classified as shown in Table 16.1 and divided roughly into experimental methods and computer-aided visualisation methods.

16.2 Experimental visualisation methods

16.2.1 Wall-tracing method

The oil-film method, typical of this technique, has long been used, so the technique is well established. There are many applications, and it is used for

Table 16.1 Classification of visualisation techniques

Visualisation technique	Air flow	Water flow	Explanation
<i>Experimental visualisation method</i>			
1. Wall surface tracing method			
Oil-film method, oil-dots method	○	●	By attaching oil film or oil dots to the body surface, from the stream pattern generated, the state including the direction of the flow can be visualised
Mass transfer method	○	●	By utilising the dissolution, evaporation or sublimation into the fluid of a film of a substance attached to the body, the flow state on the body surface can be visualised
Electrolytic corrosion method		●	By utilising the corrosion due to electrolysis, the flow state on the body surface can be visualised
Temperature-sensitive-film method	○	●	The surface temperature is visualised according to the colour distribution of a liquid crystal or such attached to the body
Pressure-sensitive-paint method	○	●	By utilising the luminescence of a substance applied to the body surface, the pressure distribution on the surface can be visualised
Pressure-sensitive-paper method	○	●	By utilising the colour density of the pressure-sensitive paper, the pressure distribution on the body surface can be visualised
2. Tuft methods			
Various tuft methods			
	○	●	Method by which the flow direction is visualised from the flight behaviour of numerous short pieces of thread (tufts). By the surface tuft method the flow near the surface is visualised, while by the depth tuft method the flow at a given point just off the surface, and by the tuft grid method the flow on a given section, and by the tuft stick method the flow at a given point is visualised, respectively
Luminescent mini-tuft method	○	●	Method by which, hardly having any effect on the flow, a single filament of nylon soaked in luminescent dye beforehand is photographed under highly luminous ultraviolet rays

Table 16.1 *Continued*

Visualisation technique	Air flow	Water flow	Explanation
3. Injected tracer method			
Injection streak line method ^(a)	○	●	Continuously inject tracers, capture the picture at a certain instant, and thus visualise the stream and streak line
Injection path line method ^(b)	○	●	Intermittently inject tracers for some duration. Visualise the path line
Suspension method ^(c)	○	●	Evenly suspend liquid or solid particles in the fluid in advance. Thus visualise the stream- and path lines
Surface floating tracer method ^(d)		●	Let the tracer float on the liquid surface and thus visualise the stream- and streak lines on the liquid surface
Time line method ^(e)	○	●	Inject the tracer vertically into the flow and thus visualise the time line
4. Chemical reaction tracer method			
Non-electrolytic reaction method	○	●	By utilising the chemical reaction of a fluid with another specified substance, the flow behaviour on the solid surface or the boundary between two fluids can be visualised
Electrolytic colouring method	○	●	By utilising an electrolytically coloured substance as the tracer, the stream line/ streak line can be visualised
5. Electric controlled tracer method			
Hydrogen bubble method		●	Utilises as the tracer hydrogen bubbles developed through electrolysing with a fine metal wire as the negative pole. Visualise the stream, streak, path and time lines
Spark tracing method	○		Visualise the time line by means of groups of discharge sparks obtained one after another by the high-voltage pulse
Smoke wire method	○		Instantaneously heat an oiled fine metal wire to produce white smoke. Visualise the streak and time lines using the white smoke as the tracer
6. Optical method			
Shadowgraph method	○	●	Let a light emitted from a single point or parallel rays go through a flow region; the flow is visualised by means of the dark and grey shadow thus developed according to the changes in light density

Table 16.1 *Continued*

Visualisation technique	Air flow	Water flow	Explanation
Schlieren photograph method	○	●	Parallel rays are made to deflect through a flow field with a difference in density. The deflected rays are cut with a knife edge, and the density gradient is visualised according to the difference in brightness thus developed
Mach-Zehnder interferometer method	○	●	Parallel rays are divided into two, one of which is made to go through a flow with a difference in density. Quantitative judgement of density and pressure is made from the interference fringe developed by combining the two
Laser holographic interferometer method	○	●	A laser light is separated into two beams. Interference, the fringe pattern, from an object and another beam (reference beam) between the scattered beam is recorded on the hologram film. Illuminating this film by the reference beam, the object can be reconstructed.
Laser light sheet method	○	●	Laser rays are made to strike a cylindrical lens or a revolving or vibrating mirror to make a sheet-like ray, and the three-dimensional flow is visualised as a two-dimensional flow by light scattered from tracer particles
Speckle method	○	●	The flow velocity distribution is obtained by optically processing the speckle pattern obtained by instantaneously photoshooting at short intervals a fluid with suspended tracer particles

Computer-aided visualisation method

7. Visualised image analysing method
PIV (Particle Imaging Velocimetry)

PTV (Particle Tracking Velocimetry) is where the flow velocity distribution is obtained by pursuing every now and then the tracer particles distributed in a fluid relatively thinly in terms of particle density. Correlation method is where the flow velocity distribution is obtained according to the similarity of distribution patterns developing at short intervals of the tracer particles distributed relatively densely in a fluid in terms of particle density

LSV (Laser Speckle Velocimetry) is where the flow velocity distribution is obtained by optically processing the speckle pattern obtained through instantaneous exposure at short intervals of tracer particles suspended in a fluid

HPIV (Holographic PIV) is where three-dimensional velocity information is obtained by recording locational information on holograms and reconstructing it

Table 16.1 *Continued*

Visualisation technique	Explanation
Computer tomography	Such integral value data as the density and temperature from whole cylindrical directions of a given section are collected, and the density and temperature distribution on the section is obtained through computation
Remote sensing	The type and conditions of a body are clarified by capturing the original electromagnetic waves emitted from the body by an aircraft or satellite
Thermographical method	By catching the infrared rays radiated from the liquid surface, the surface temperature can be measured
8. Numerical data visualisation methods	
Contour manifestation method	Physically equal values are connected by a contour
Area colouring manifestation method	Manifestation is made by painting the areas in colours respectively corresponding to their levels of physical quantity
Isosurface manifestation method	The values of physically equal value are three-dimensionally manifested in a surface
Volume rendering method	The levels of equi-value area manifestation are manifested by changing their degree of transparency
Vector manifestation method	The size and direction of the flow velocity vector etc. are manifested in arrow marks
Animation method	Still images on a display are developed into as-if-moving images by continuous shooting
9. Measured data visualisation method	
	Methods are practised such as those which utilise flow velocimeters and pressure gauges where the velocity distribution, pressure distribution, etc., obtained are to be manifested in an image by processing the data simultaneously, and those which utilise the acoustic intensity method so that the size and direction at every point in the observation arena are manifested in terms of vectors

For injection tracer methods, the names of typical tracers are as follows:

^(a) smoke (○), colouring matter (●); ^(b) soap bubble (○), air bubble (●), oil drop (●), luminescent particle (●); ^(c) metaldehyde (○), air bubble (○), cavitation (●), liquid tracer (●), aluminium powder (●), polystyrene particle (●); ^(d) aluminium powder (●), sawdust (●), foaming polystyrene (●); ^(e) smoke (○), colouring matter (●).

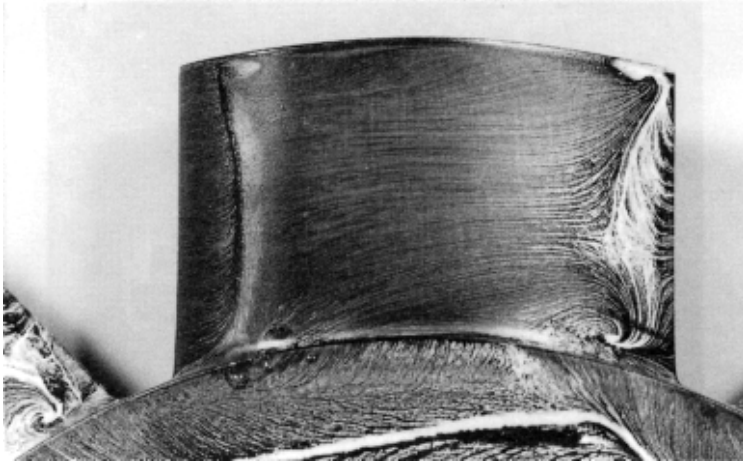

Fig.16.1 Limiting streamlines of Wells turbine for wave power generator (revolving direction is counterclockwise) in water, flow velocity 3.2 m/s, angle of attack 11°

both water and air flow. The flows in the neighbourhood of a body surface, of a wall face inside fluid machinery, etc., have been observed. Figure 16.1 shows the oil-film pattern on the blade surface of a Wells turbine for a wave power generator.¹ From this pattern the nature of the internal flow can be surmised.

16.2.2 Tuft method

Although this is an unsophisticated method widely used for fluid experiments for some time, it has recently become easier to use and more informative as detailed experiments and analyses have been made of the static and dynamic tuft characteristics. It is utilised for visualising flows near and around the surfaces of aircraft, hulls and automobiles as well as those behind them, the internal flows of pumps and blowers, and ventilation flows in rooms. Figure 16.2 shows an example of the visualised flow behind an automobile,² while Fig. 16.3 shows that around a superexpress train.³ Figure 16.4 shows an example of the utilisation of extremely fine fluorescent mini-tufts which hardly disturb the flow.⁴

16.2.3 Injection tracer method

For water flow, the colour streak method has widely been used for a long time. In the suspension method, aluminium powder or polystyrene particles

¹ Tagori, T, *et al.*, *Flow Visualization*, 4, Suppl. (1984), 51.

² Tagori, T. *et al.*, *Proc. Flow Visualization Symp.*, (1980), 13.

³ Japan National Railways.

⁴ Saga, T. and Kobayashi, T., *Flow Visualization*, 5, Suppl. (1985), 87.

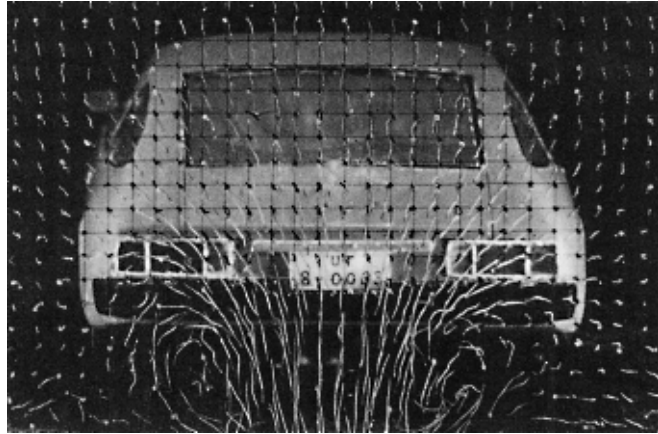

Fig.16.2 Wake behind an automobile (tuft grid method) in water, flow velocity 1 m/s, length 530 mm (scale 1: 8), $Re = 5 \times 10^5$

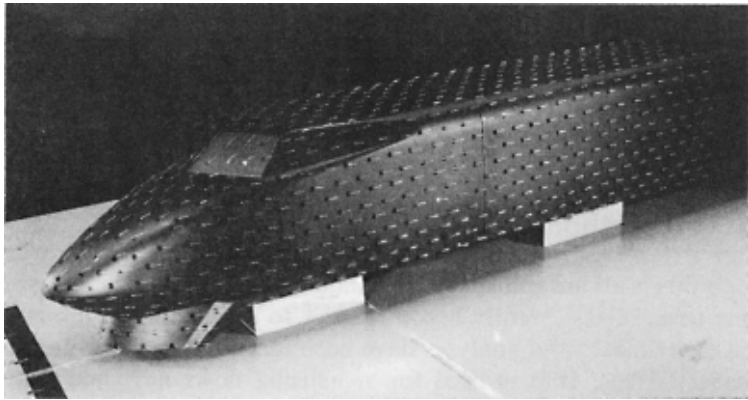

Fig.16.3 Flow around a superexpress train (surface tuft method)

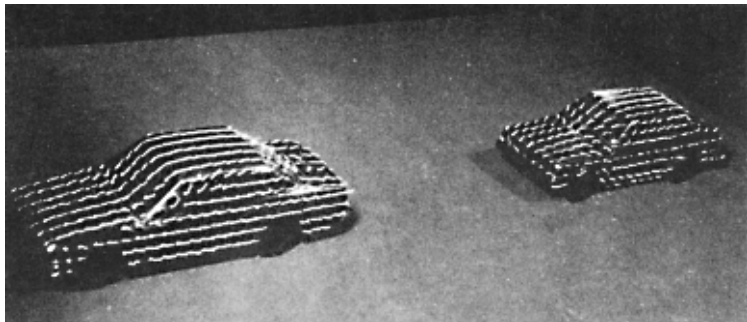
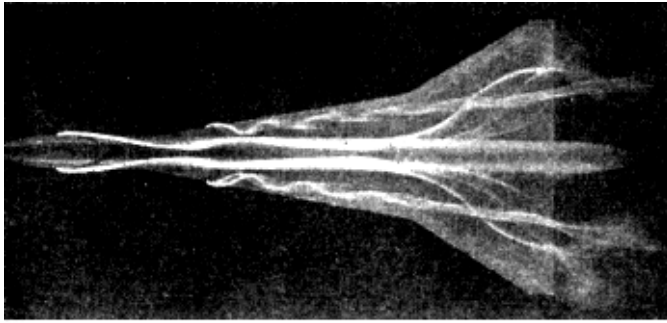
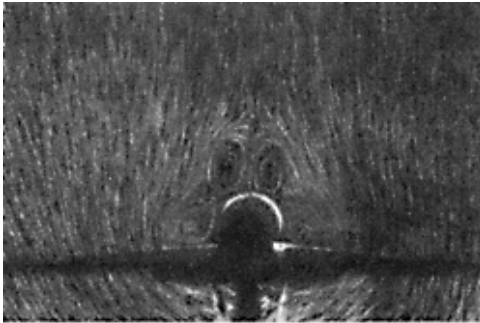

Fig.16.4 Flow around an automobile (fluorescent mini-tuft method)



(a)



(b)

Fig.16.5 Flow around a double delta wing aircraft in water, angle of attack 15° : (a) colour streak line method; (b) suspension method (air bubble method)

are used, while in the surface floating tracer method, sawdust and aluminium powder are used. The smoke method is used for air flows.

There are many examples for visualising the flow around or behind wings, hulls, automobiles, buildings and bridge piers, as well as for the internal flow of pipe lines, blood vessels and pumps.

Figure 16.5 is a photograph where the flow around a double delta wing

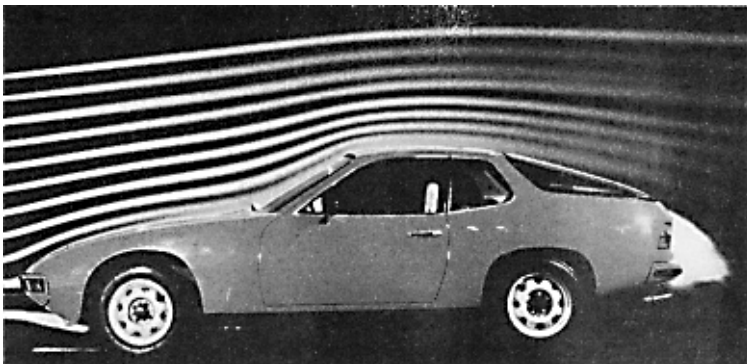

Fig.16.6 Flow around an automobile (smoke method)

aircraft is visualised by a water flow.⁵ It can be seen how the various vortices develop. These vortices act to increase the lift necessary for a high-speed aircraft to undertake low-speed flight.

Plate 7⁶ and Fig. 16.6⁷ visualise the flow around an automobile by the smoke method. The flow pattern is clearly seen.

Figure 16.7 shows observation, by the floating sawdust method, of the flow in a bent divergent pipe.⁸

Figure 16.8 visualises a Kármán vortex street using as the tracer the white condensation produced when water is electrolysed with the cylinder as the positive pole.⁹

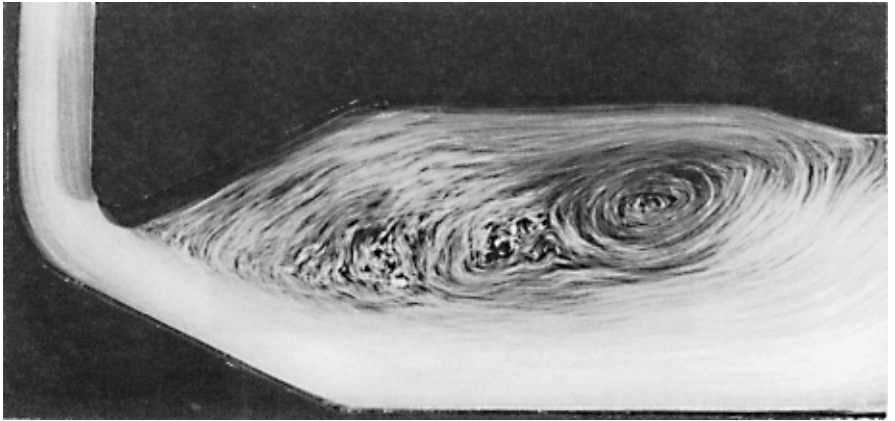

Fig.16.7 Flow in a bent divergent pipe (floating sawdust method) in water, flow velocity 0.4 m/s, $Re = 2.8 \times 10^4$

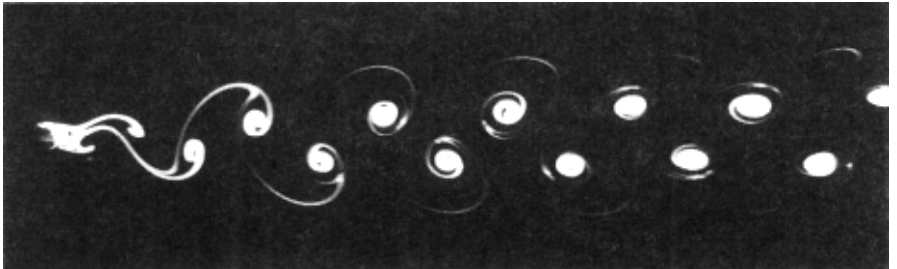

Fig.16.8 Kármán vortex street behind a cylinder (electrolytic precipitation method) in water, flow velocity 10 mm/s, diameter of cylinder 10 mm, $Re = 105$

⁵ Werle, H., *Proc. ISFV, Tokyo* (1977), 39.

⁶ Flow Visualization Society, Tokyo, *Flow Visualization Handbook*, (1997), 103.

⁷ Hucho, W. H. and Janssen, L. J., *Proc. ISFV, Tokyo* (1997), 103.

⁸ Akashi, K. *et al.*, *Symp. on Flow Visualization (1st)*, (1973), 100.

⁹ Taneda, S., *Fluid Mechanics Learned from Pictures*, Asakura Shoten, (1988), 92.

16.2.4 Chemical reaction tracer method

There are various techniques using chemically reactive substances. Since they have negligible change in density due to chemical reaction, the settling velocity of the tracer is small and thus many of them are suitable for visualising low-velocity flow.

The method has been used for visualising the flow around and behind a flat board, wing and hull, the flow inside a pump and boiler, and natural/thermal convection.

Figure 16.9 is an observation of flow using the streaks developed by injecting saturated liquid ammonium sulphide through a fine tube onto a mixture of white lead and a quick-drying oil which has been applied to the surface of a model yacht.¹⁰

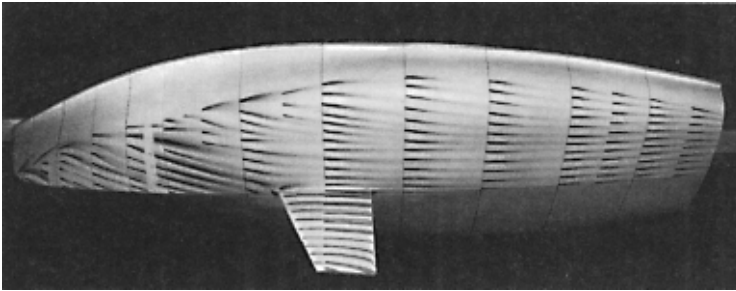

Fig.16.9 Flow on a model yacht surface (surface film colouring method) in water, flow velocity 1.0 m/s, length of model 1.5 m, $Re = 1.34 \times 10^6$, white lead and ammonium sulphide used

16.2.5 Electrically controlled tracer method

Included in this method are three categories: the hydrogen bubble method, spark tracing method and smoke wire method. Any one of them is capable of providing quantitative measurement.

By these methods the flow around and the vortex behind a cylinder, flat board, sphere, wing, aircraft and hull, the flow in a cylinder, the flow around a valve, and the flow in a blower/compressor have been observed.

Plate 8 is a picture visualising the flow around a cylinder by the hydrogen bubble method,¹¹ while Plate 9 shows the flow around a sphere by the spark tracing method.¹² Figure 16.10 shows the flow around a wing by the same method,¹³ and Fig. 16.11 shows the flow around an automobile by the smoke wire method.¹⁴

¹⁰ Matsui, S., Nishinohon Ryutaigiken Co., Nagasaki, Japan.

¹¹ Endo, H. *et al.*, *Symp. of Flow Visualization (2nd)*, (1947), 135.

¹² Nakayama, Y., *Flow Visualization*, 8 (1988), 14.

¹³ Nakayama, Y. *et al.*, *Symp. on Flow Visualization (4th)*, (1976), 105.

¹⁴ Nakayama, Y., Faculty of Engineering, Tokai University.

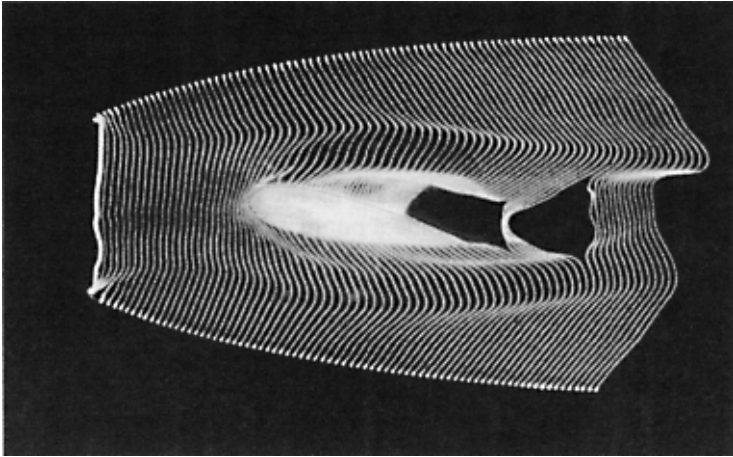

Fig.16.10 Flow around a wing (spark tracing method) in air, flow velocity 28 m/s. angle of attack 10° , $Re = 7.4 \times 10^4$

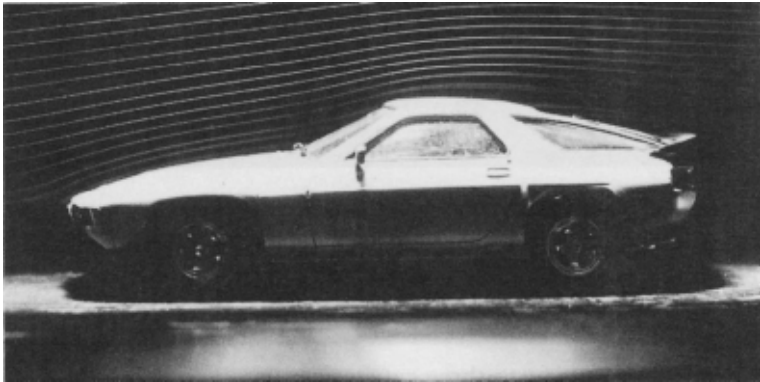

Fig.16.11 Flow around an automobile (smoke wire method)

16.2.6 Optical visualisation method

This method, whose most significant characteristic is the capability of complete visualisation without affecting the flow, is widely used. The Schlieren method utilises the change in diffraction rate due to the change in density (temperature). The interference method, which uses the fact that the number of interference fringes is proportional to the difference in density, is mostly applied to air flow. For free surface water flow, the stereophotography method is used. The unevenness of a liquid surface is stereophotographed to determine the difference in the height of the liquid surface and thus the state of flow is known. The moiré method is also used for water flows. The state of the flow is checked by obtaining as light and dark stripes the contours indicating the unevenness of the liquid surface.



Fig.16.12 Flow at bottom dead point of vertically vibrating wing (Schlieren method) in air, flow velocity 5 m/s, chord length 100 mm, $Re = 3 \times 10^4$, vibration frequency 90 Hz, single amplitude 4 mm

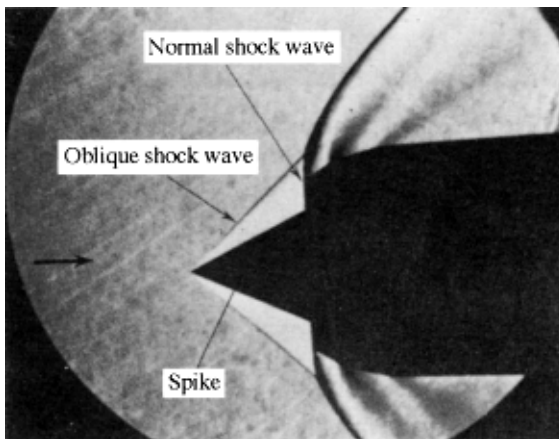

Fig.16.13 Flow at air inlet of supersonic aircraft engine (colour Schlieren method), $M = 2.0$, $Re = 1.0 \times 10^7$

A new technique, the laser holographic method, has been developed recently. An optical reference path is added to the optical system of the shadowgraph method or the Schlieren method.

Various actual examples of the optical visualisation method are shown in Plates 4¹⁵ and 10¹⁶ and Figs 16.12¹⁷, 16.13¹⁸ and 16.14.¹⁹

¹⁵ Hara, N. and Yoshida, T., *Proc. of FLUCOME Tokyo '85*, Vol. II (1986), 725.

¹⁶ Fujii, K., *Journal of Visualization*, 15 (1995), 142.

¹⁷ Ohashi, H. and Ishikawa, N., *Journal of the ISME*, 74 (1975), 1500.

¹⁸ Asanuma, T. *et al.*, Report of Aerospace Research Institute of University of Tokyo, 9 (1973), 499.

¹⁹ Nagayama, T. and Adachi, T., *Joint Gas Turbine Congress*, Paper No. 36 (1977).

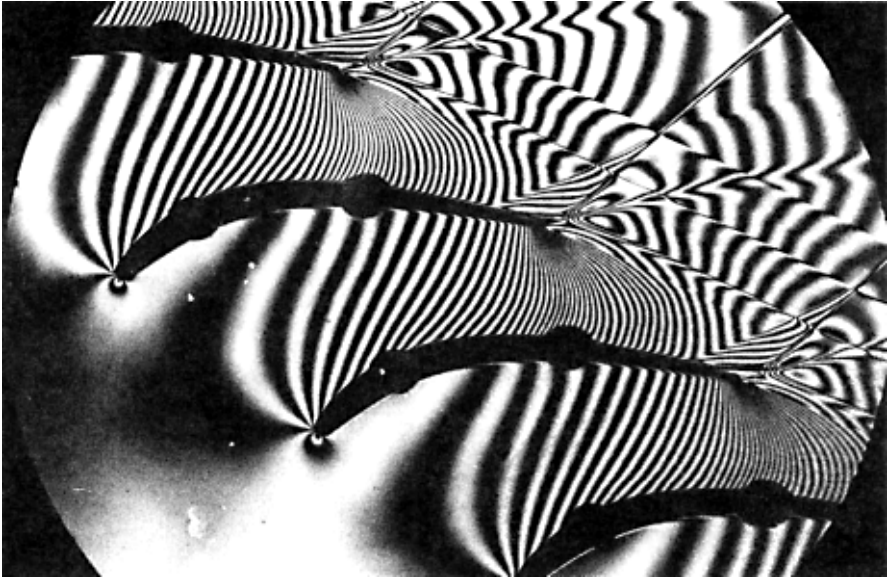

Fig.16.14 Equidensity interference fringe photograph of driven blade on low-pressure stage in steam turbine (Mach-Zehnder interferometer method) in air, inlet Mach number 0.275, outlet Mach number 2.123, pitch 20 mm

16.3 Computer-aided visualisation methods

16.3.1 Visualised image analysis

In this method, a visualised image is put into a still or video camera so that its density values are digitised. It is then put into a computer to be processed analytically, statistically, in colour distribution and otherwise, and thus is made much easier to interpret. Various techniques for this method have been developed. Among them, PIV (Particle Imaging Velocimetry) in particular has recently been popular. As an example of PTV (Particle Tracking Velocimetry), Plate 11 shows the velocity vectors obtained for flow over a cylinder by following, from time to time, the spherical plastic tracer particles of diameter 0.5 mm suspended in the water.²⁰ Plate 12 is an example of an image treated by a density correlation method. The image was obtained by injecting a smoke tracer into the room from the floor under the chair on which a man was sitting and natural convection around a human body was visualised.²¹ Figure 16.15 is an example of the hydrogen bubble technique

²⁰ Boucher, R. F. and Kamala, M. A., *Atlas of Visualization*, Vol. 1 (1992), 197.

²¹ Kobayashi, T. *et al.*, *Journal of Visualization*, 17 (1977), 38.

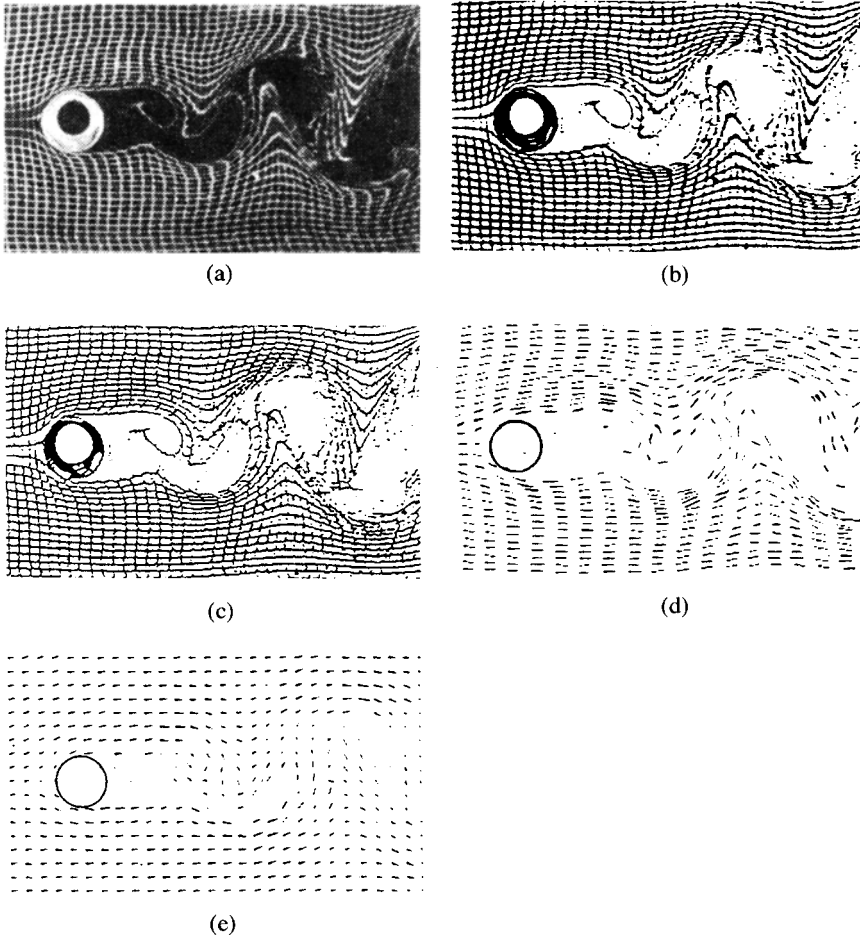

Fig.16.15 Kármán vortex street behind a cylinder (hydrogen tube method): (a) visualised image; (b) binarisation; (c) change to fine line; (d) velocity vector; (e) velocity vector at grid point

where the time line and the streak line are visualised simultaneously. The visualised image is caught by a CCD camera, converted to binary codes and fine lines, and thus the velocity vector is obtained.²²

In Plate 4, the flow around a cone flying at supersonic speed is visualised by the laser holographic interferometer method, and the density distribution on a section is obtained by the computer tomography method.

16.3.2 Numerical data visualisation method

In this method, a flow field is numerically analysed by computer, and its

²² Nakayama, Y. *et al.*, Report of Research Results (5th), Faculty of Engineering, Tokai University (1987), 1.

enormous computational output is presented in an easy-to-understand figure or image by computer graphics techniques.

The kinds of presentation include: contours, where physically equal values are connected by a curve; area colouring, where areas are painted in colours respectively corresponding to the physical quantity level of areas; isosurface, where physically equal values are three-dimensionally manifested in surfaces; volume rendering, where the levels expressed in isosurfaces are manifested by changing the degree of transparency; and vectorial, where sizes and directions of flow velocity etc. are manifested by arrow marks. Presentation can also be as graphs or animation.

Examples of contour presentation are Fig. 15.4, where streamlines (which are the contours of stream function) and contours of vorticity are manifested, Fig. 15.10, where contours of density are shown, and Plate 5 where the presentation is made three-dimensionally.

Examples of area colouring are Plates 1(a) and 2, where the pressure distribution is shown, and Plate 6(a) where the presentation is three-dimensional. And an example of isosurface presentation is shown in Plate 13,²³ and those of the vector presentation in Fig. 15.25(b), Fig. 15.26(b), Plate 1(b) and Plate 3.

16.3.3 Measured data visualisation

If a flow field is minutely measured with a Pitot tube, hot-wire anemometer, laser Doppler velocimeter, pressure gauge, thermometer, etc., such results can be processed by computer, and thus the phenomena are visualised as images.

In Plate 14, pressure-sensitive light-emitting diodes are placed transversely. The total pressure pattern of a wake of an aircraft wing is then obtained by photographing the diode emissions, whose colours change with total pressure.²⁴ Figure 16.16 shows the measured result of the flow velocity in the area behind a model passenger car obtained using a three-dimensional laser Doppler velocimeter, presented as a velocity vector diagram.²⁵ In Fig. 16.17 the acoustic power flow from a cello is visualised by the acoustic intensity method. The size and direction of the energy flow at each point is obtained through a computational process from the cross-vector of the sonic pressure signal on a microphone.²⁶

²³ Miyachi, H., *How to Visualize your Data using AVS*, (1995), Fig. 5.28, Kubota Co., Tokyo.

²⁴ Visualization Society of Japan, *Fantasy of Flow*, (1993), 47, Ohmsha, Tokyo, and IOS Press, Amsterdam.

²⁵ Visualization Society of Japan, *Computer Graphics of Flow*, (1996), 124, Asakura Shoten, Tokyo.

²⁶ Tachibana, H. *et al.*, *Atlas of Visualization*, Vol. 2, (1996), 203.

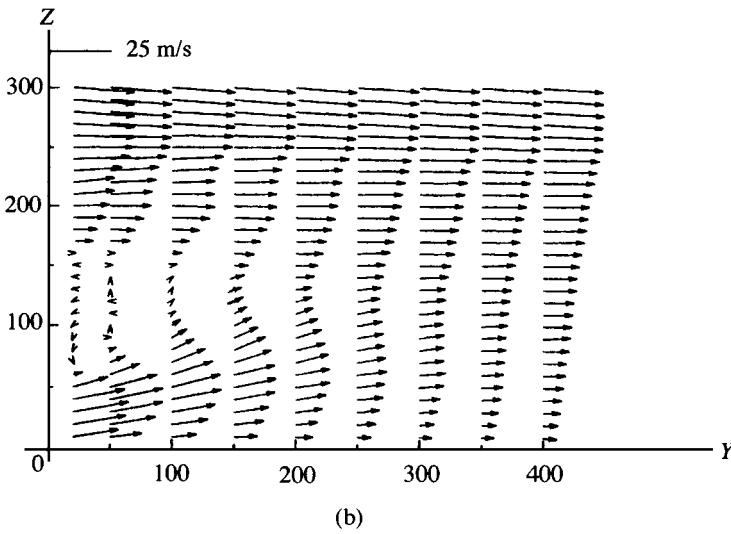
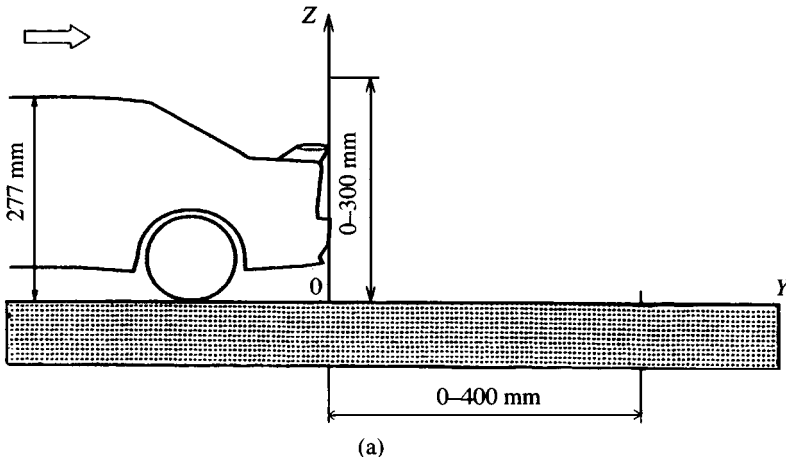

Fig.16.16 Flow behind an automobile with spoiler (laser Doppler velocimeter method): (a) measured region; (b) mean velocity vector

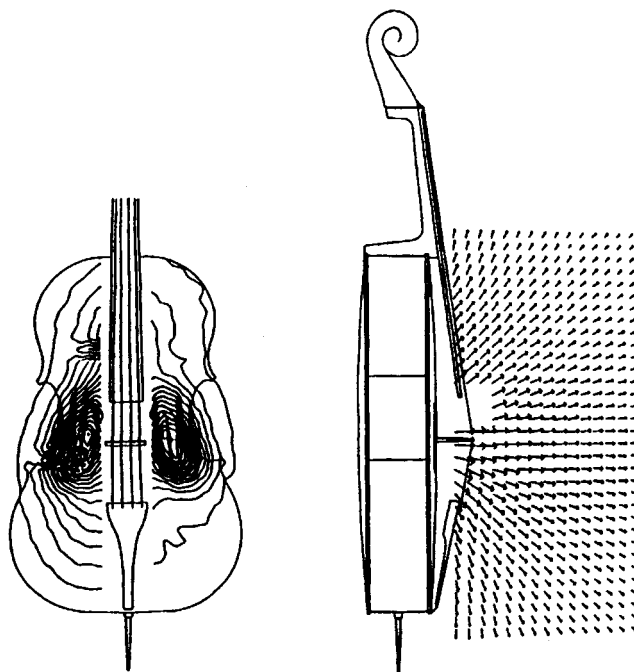

Fig.16.17 Radiating power flow of a cello (acoustic intensity method)