

Chapter 6

Adapted from the
Complete Solutions Manual

for
James Stewart's
Calculus – 5th Edition

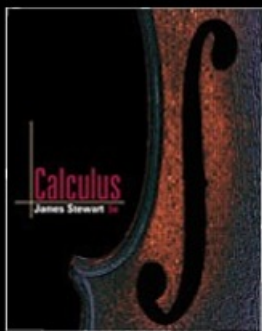

Calculus 5e
James Stewart
ISBN 0-534-39339-X

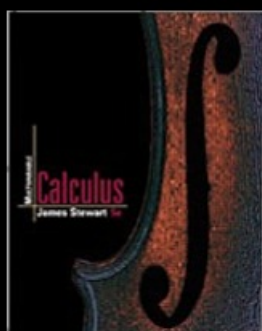

Calculus 5e - Multivariable
James Stewart
ISBN 0-534-39357-8

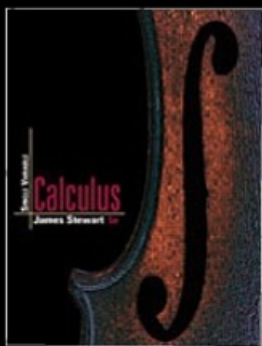

Calculus 5e - Single Variable
James Stewart
ISBN 0-534-39366-7

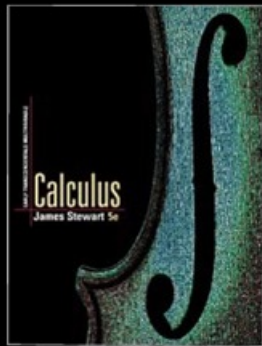

Calculus 5e - Multivariable
Early Transcendentals
James Stewart
ISBN 0-534-41778-7

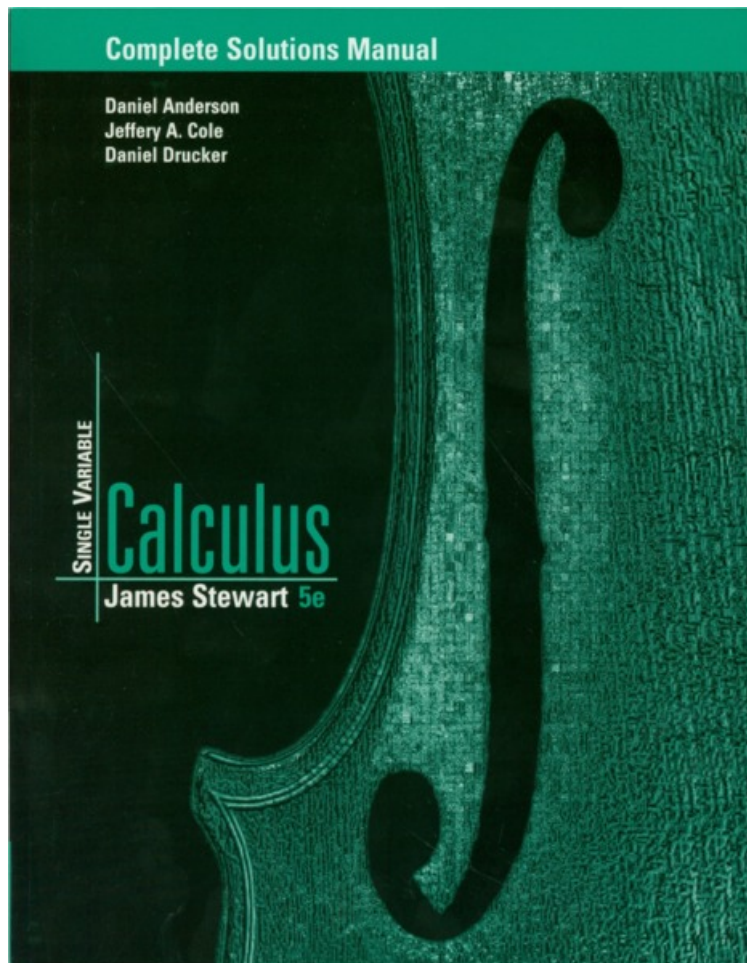

6 □ APPLICATIONS OF INTEGRATION

6.1 Areas between Curves

$$1. A = \int_{x=0}^{x=4} (y_T - y_B) dx = \int_0^4 [(5x - x^2) - x] dx = \int_0^4 (4x - x^2) dx$$

$$= [2x^2 - \frac{1}{3}x^3]_0^4 = (32 - \frac{64}{3}) - (0) = \frac{32}{3}$$

$$2. A = \int_0^6 [2x - (x^2 - 4x)] dx = \int_0^6 (6x - x^2) dx = [3x^2 - \frac{1}{3}x^3]_0^6 = 108 - 72 = 36$$

$$3. A = \int_{y=0}^{y=1} (x_R - x_L) dy = \int_0^1 [\sqrt{y} - (y^2 - 1)] dy = \int_0^1 (y^{1/2} - y^2 + 1) dy$$

$$= [\frac{2}{3}y^{3/2} - \frac{1}{3}y^3 + y]_0^1 = (\frac{2}{3} - \frac{1}{3} + 1) - (0) = \frac{4}{3}$$

$$4. A = \int_0^3 [(2y - y^2) - (y^2 - 4y)] dy = \int_0^3 (-2y^2 + 6y) dy$$

$$= [-\frac{2}{3}y^3 + 3y^2]_0^3 = (-18 + 27) - 0 = 9$$

$$5. A = \int_{-1}^2 [(9 - x^2) - (x + 1)] dx$$

$$= \int_{-1}^2 (8 - x - x^2) dx$$

$$= [8x - \frac{x^2}{2} - \frac{x^3}{3}]_{-1}^2$$

$$= (16 - 2 - \frac{8}{3}) - (-8 - \frac{1}{2} + \frac{1}{3})$$

$$= 22 - 3 + \frac{1}{2} = \frac{39}{2}$$

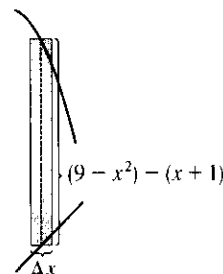
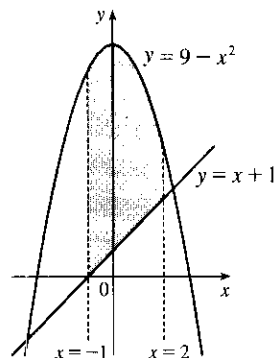

$$6. A = \int_{\pi/2}^{\pi} (x - \sin x) dx$$

$$= [\frac{x^2}{2} + \cos x]_{\pi/2}^{\pi}$$

$$= (\frac{\pi^2}{2} - 1) - (\frac{\pi^2}{8} + 0)$$

$$= \frac{3\pi^2}{8} - 1$$

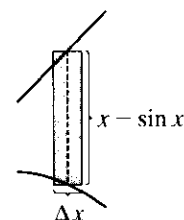
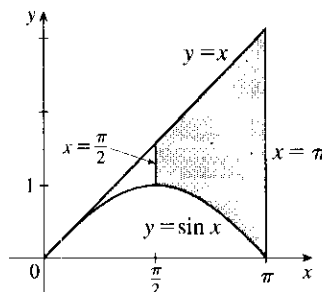

7. The curves intersect when $x = x^2 \Rightarrow x^2 - x = 0 \Leftrightarrow x(x - 1) = 0 \Leftrightarrow x = 0, 1$.

$$\begin{aligned} A &= \int_0^1 (x - x^2) dx \\ &= \left[\frac{1}{2}x^2 - \frac{1}{3}x^3 \right]_0^1 \\ &= \frac{1}{2} - \frac{1}{3} \\ &= \frac{1}{6} \end{aligned}$$

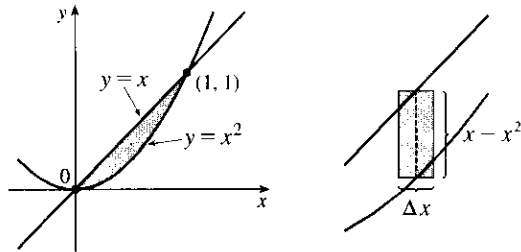

$$\begin{aligned} 8. A &= \int_{-1}^1 (x^2 - x^4) dx \\ &= 2 \int_0^1 (x^2 - x^4) dx \\ &= 2 \left[\frac{1}{3}x^3 - \frac{1}{5}x^5 \right]_0^1 \\ &= 2 \left(\frac{1}{3} - \frac{1}{5} \right) = \frac{4}{15} \end{aligned}$$

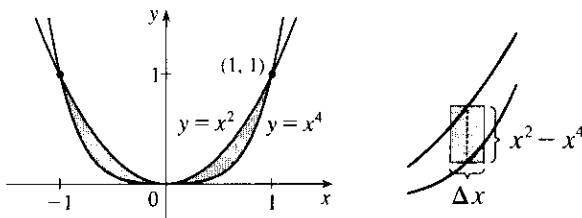

9. First find the points of intersection: $\sqrt{x+3} = \frac{x+3}{2} \Rightarrow (\sqrt{x+3})^2 = \left(\frac{x+3}{2}\right)^2 \Rightarrow x+3 = \frac{1}{4}(x+3)^2$
 $\Rightarrow 4(x+3) - (x+3)^2 = 0 \Rightarrow (x+3)[4 - (x+3)] = 0 \Rightarrow (x+3)(1-x) = 0 \Rightarrow x = -3$ or 1 . So

$$A = \int_{-3}^1 \left(\sqrt{x+3} - \frac{x+3}{2} \right) dx = \left[\frac{2}{3}(x+3)^{3/2} - \frac{(x+3)^2}{4} \right]_{-3}^1 = \left(\frac{16}{3} - 4 \right) - (0 - 0) = \frac{4}{3}$$

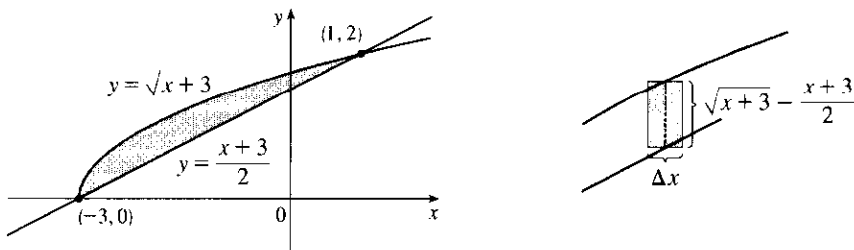

10. $1 + \sqrt{x} = \frac{3+x}{3} = 1 + \frac{x}{3} \Rightarrow \sqrt{x} = \frac{x}{3} \Rightarrow x = \frac{x^2}{9} \Rightarrow 9x - x^2 = 0 \Rightarrow x(9-x) = 0 \Rightarrow x = 0$
 or 9 , so

$$\begin{aligned} A &= \int_0^9 \left[(1 + \sqrt{x}) - \left(\frac{3+x}{3} \right) \right] dx = \int_0^9 \left[(1 + \sqrt{x}) - \left(1 + \frac{x}{3} \right) \right] dx \\ &= \int_0^9 (\sqrt{x} - \frac{1}{3}x) dx = \left[\frac{2}{3}x^{3/2} - \frac{1}{6}x^2 \right]_0^9 = 18 - \frac{27}{2} = \frac{9}{2} \end{aligned}$$

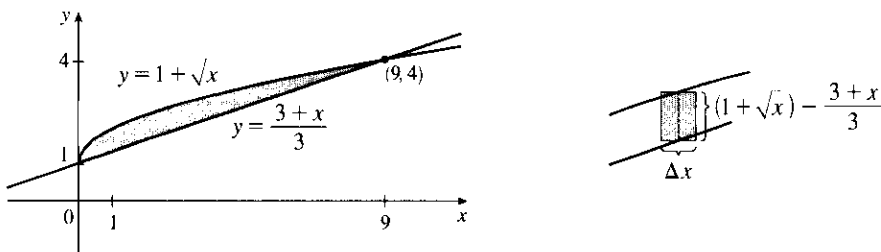

$$\begin{aligned}
 11. A &= \int_0^1 (\sqrt{x} - x^2) dx \\
 &= \left[\frac{2}{3}x^{3/2} - \frac{1}{3}x^3 \right]_0^1 \\
 &= \frac{2}{3} - \frac{1}{3} \\
 &= \frac{1}{3}
 \end{aligned}$$

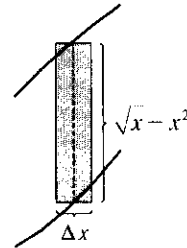
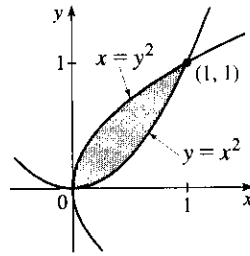

$$\begin{aligned}
 12. x = \sqrt[3]{x} &\Rightarrow x^3 = x \Rightarrow x^3 - x = 0 \Rightarrow x(x^2 - 1) = 0 \Rightarrow x(x+1)(x-1) = 0 \Rightarrow \\
 &x = -1, 0, \text{ or } 1, \text{ so}
 \end{aligned}$$

$$\begin{aligned}
 A &= \int_{-1}^1 |\sqrt[3]{x} - x| dx = \int_{-1}^0 (x - \sqrt[3]{x}) dx + \int_0^1 (\sqrt[3]{x} - x) dx = 2 \int_0^1 (x^{1/3} - x) dx \quad [\text{by symmetry}] \\
 &= 2 \left[\frac{3}{4}x^{4/3} - \frac{1}{2}x^2 \right]_0^1 = 2 \left(\frac{3}{4} - \frac{1}{2} \right) = \frac{1}{2}
 \end{aligned}$$

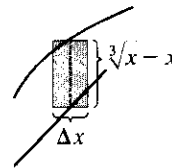
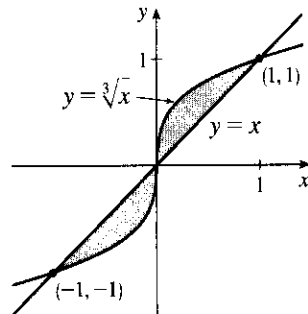

$$13. 12 - x^2 = x^2 - 6 \Leftrightarrow 2x^2 = 18 \Leftrightarrow x^2 = 9 \Leftrightarrow x = \pm 3, \text{ so}$$

$$\begin{aligned}
 A &= \int_{-3}^3 [(12 - x^2) - (x^2 - 6)] dx = 2 \int_0^3 (18 - 2x^2) dx \quad [\text{by symmetry}] \\
 &= 2 \left[18x - \frac{2}{3}x^3 \right]_0^3 = 2[(54 - 18) - 0] = 2(36) = 72
 \end{aligned}$$

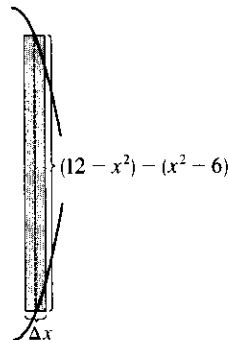
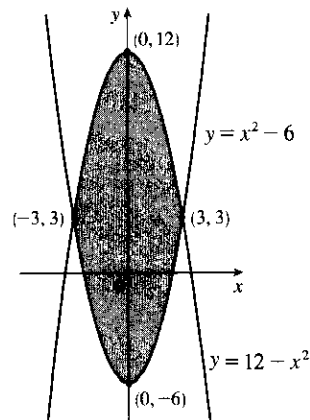

$$14. x^3 - x = 3x \Rightarrow x^3 - 4x = 0 \Rightarrow x(x^2 - 4) = 0 \Rightarrow x(x+2)(x-2) = 0 \Rightarrow x = 0, -2, \text{ or } 2.$$

By symmetry,

$$\begin{aligned} A &= \int_{-2}^2 |3x - (x^3 - x)| dx = 2 \int_0^2 [3x - (x^3 - x)] dx = 2 \int_0^2 (4x - x^3) dx = 2 \left[2x^2 - \frac{1}{4}x^4 \right]_0^2 \\ &= 2(8 - 4) = 8 \end{aligned}$$

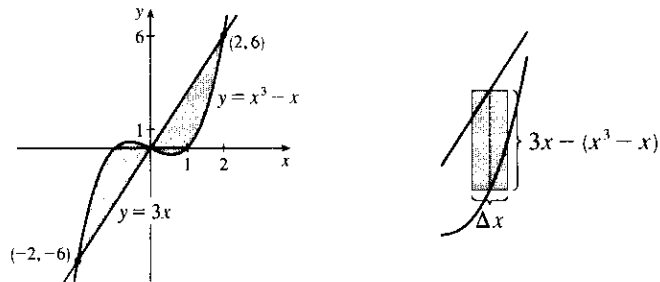

$$15. \frac{1}{2}x = \sqrt{x} \Rightarrow \frac{1}{4}x^2 = x \Rightarrow x^2 - 4x = 0 \Rightarrow x(x - 4) = 0 \Rightarrow x = 0 \text{ or } 4, \text{ so}$$

$$\begin{aligned} A &= \int_0^4 (\sqrt{x} - \frac{1}{2}x) dx + \int_4^9 (\frac{1}{2}x - \sqrt{x}) dx = \left[\frac{2}{3}x^{3/2} - \frac{1}{4}x^2 \right]_0^4 + \left[\frac{1}{4}x^2 - \frac{2}{3}x^{3/2} \right]_4^9 \\ &= \left[\left(\frac{16}{3} - 4 \right) - 0 \right] + \left[\left(\frac{81}{4} - 18 \right) - \left(4 - \frac{16}{3} \right) \right] = \frac{81}{4} + \frac{32}{3} - 26 = \frac{59}{12} \end{aligned}$$

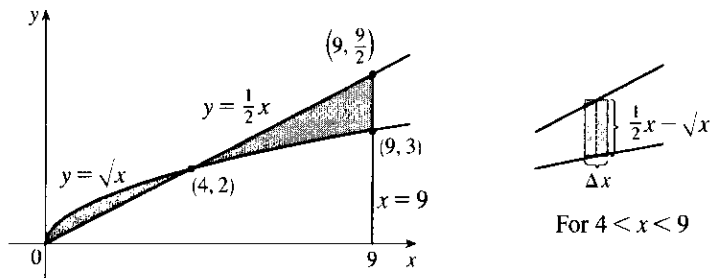

$$\begin{aligned} 16. A &= \int_{-3}^3 |(8 - x^2) - x^2| dx = 2 \int_0^3 |8 - 2x^2| dx = 2 \int_0^2 (8 - 2x^2) dx + 2 \int_2^3 (2x^2 - 8) dx \\ &= 2 \left[8x - \frac{2}{3}x^3 \right]_0^2 + 2 \left[\frac{2}{3}x^3 - 8x \right]_2^3 = 2 \left[\left(16 - \frac{16}{3} \right) - 0 \right] + 2 \left[(18 - 24) - \left(\frac{16}{3} - 16 \right) \right] \\ &= 32 - \frac{32}{3} + 20 - \frac{32}{3} = 52 - \frac{64}{3} = \frac{92}{3} \end{aligned}$$

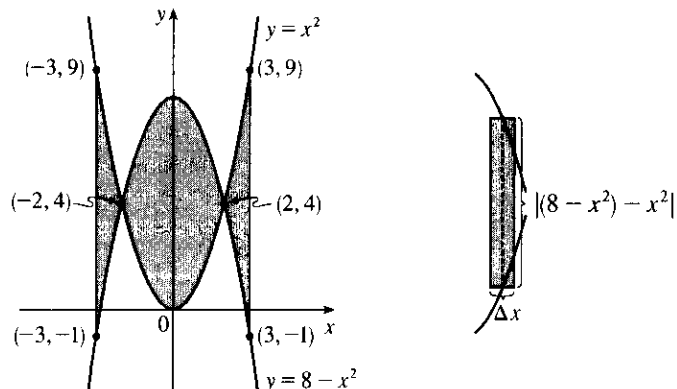

17. $2y^2 = 1 - y \Leftrightarrow 2y^2 + y - 1 = 0 \Leftrightarrow (2y - 1)(y + 1) = 0 \Leftrightarrow y = \frac{1}{2}$ or -1 , so $x = \frac{1}{2}$ or 2 and

$$A = \int_{-1}^{1/2} [(1 - y) - 2y^2] dy = \int_{-1}^{1/2} (1 - y - 2y^2) dy = \left[y - \frac{1}{2}y^2 - \frac{2}{3}y^3 \right]_{-1}^{1/2}$$

$$= \left(\frac{1}{2} - \frac{1}{8} - \frac{1}{12} \right) - \left(-1 - \frac{1}{2} + \frac{2}{3} \right) = \frac{7}{24} - \left(-\frac{5}{6} \right) = \frac{7}{24} + \frac{20}{24} = \frac{27}{24} = \frac{9}{8}$$

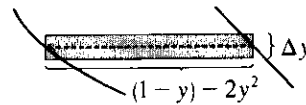
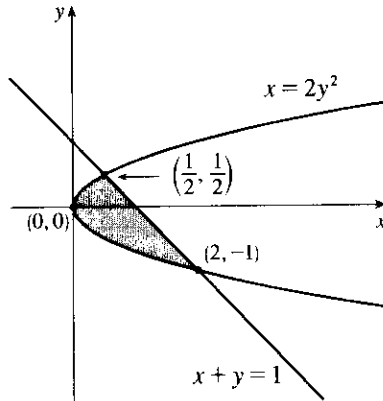

18. $4x + x^2 = 12 \Leftrightarrow (x + 6)(x - 2) = 0 \Leftrightarrow x = -6$ or $x = 2$, so $y = -6$ or $y = 2$ and

$$A = \int_{-6}^2 \left[\left(-\frac{1}{4}y^2 + 3 \right) - y \right] dy = \left[-\frac{1}{12}y^3 - \frac{1}{2}y^2 + 3y \right]_{-6}^2 = \left(-\frac{2}{3} - 2 + 6 \right) - (18 - 18 - 18) = 22 - \frac{2}{3} = \frac{64}{3}$$

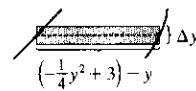
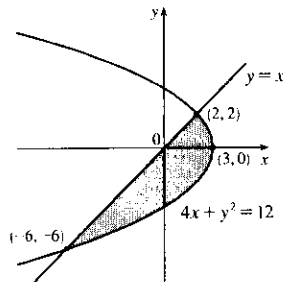

19. The curves intersect when $1 - y^2 = y^2 - 1 \Leftrightarrow 2 = 2y^2 \Leftrightarrow y^2 = 1 \Leftrightarrow y = \pm 1$.

$$A = \int_{-1}^1 [(1 - y^2) - (y^2 - 1)] dy$$

$$= \int_{-1}^1 2(1 - y^2) dy$$

$$= 2 \cdot 2 \int_0^1 (1 - y^2) dy$$

$$= 4 \left[y - \frac{1}{3}y^3 \right]_0^1 = 4 \left(1 - \frac{1}{3} \right) = \frac{8}{3}$$

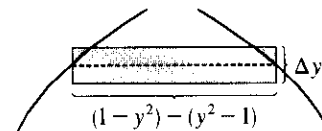
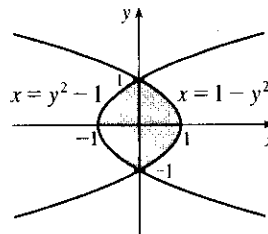

20. $A = 2 \int_0^1 \left[\sin\left(\frac{\pi x}{2}\right) - x \right] dx = 2 \left[-\frac{2}{\pi} \cos\left(\frac{\pi x}{2}\right) - \frac{x^2}{2} \right]_0^1 = 2 \left[\left(0 - \frac{1}{2}\right) - \left(-\frac{2}{\pi} - 0\right) \right] = \frac{4}{\pi} - 1$

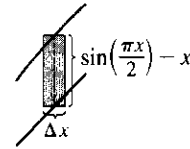
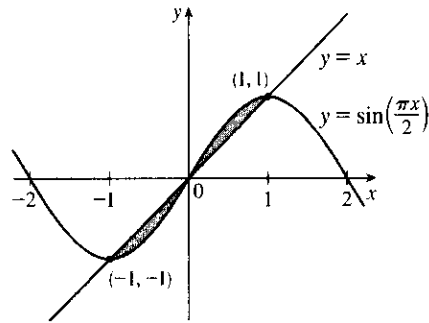

21. Notice that $\cos x = \sin 2x = 2 \sin x \cos x \Leftrightarrow$
 $2 \sin x \cos x - \cos x = 0 \Leftrightarrow \cos x (2 \sin x - 1) = 0 \Leftrightarrow$
 $2 \sin x = 1$ or $\cos x = 0 \Leftrightarrow x = \frac{\pi}{6}$ or $\frac{\pi}{2}$.

$$A = \int_0^{\pi/6} (\cos x - \sin 2x) dx + \int_{\pi/6}^{\pi/2} (\sin 2x - \cos x) dx$$

$$= \left[\sin x + \frac{1}{2} \cos 2x \right]_0^{\pi/6} + \left[-\frac{1}{2} \cos 2x - \sin x \right]_{\pi/6}^{\pi/2}$$

$$= \frac{1}{2} + \frac{1}{2} \cdot \frac{1}{2} - (0 + \frac{1}{2} \cdot 1) + \left(\frac{1}{2} - 1 \right) - \left(-\frac{1}{2} \cdot \frac{1}{2} - \frac{1}{2} \right) = \frac{1}{2}$$

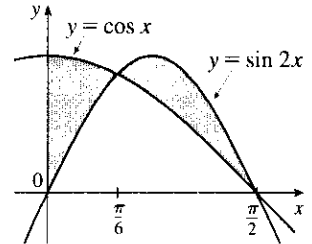

22. $\sin x = \sin 2x = 2 \sin x \cos x$ when $\sin x = 0$ and when $\cos x = \frac{1}{2}$;
 that is, when $x = 0$ or $\frac{\pi}{3}$.

$$A = \int_0^{\pi/3} (\sin 2x - \sin x) dx + \int_{\pi/3}^{\pi/2} (\sin x - \sin 2x) dx$$

$$= \left[-\frac{1}{2} \cos 2x + \cos x \right]_0^{\pi/3} + \left[\frac{1}{2} \cos 2x - \cos x \right]_{\pi/3}^{\pi/2}$$

$$= \left[-\frac{1}{2} \left(-\frac{1}{2}\right) + \frac{1}{2} \right] - \left(-\frac{1}{2} + 1\right)$$

$$+ \left(-\frac{1}{2} - 0\right) - \left[\frac{1}{2} \left(-\frac{1}{2}\right) - \frac{1}{2}\right] = \frac{1}{2}$$

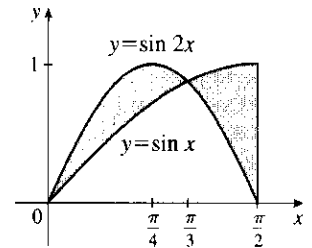

23. From the graph, we see that the curves intersect at $x = 0$, $x = \frac{\pi}{2}$, and $x = \pi$. By symmetry,

$$A = \int_0^{\pi} \left| \cos x - \left(1 - \frac{2x}{\pi}\right) \right| dx = 2 \int_0^{\pi/2} \left[\cos x - \left(1 - \frac{2x}{\pi}\right) \right] dx = 2 \int_0^{\pi/2} \left(\cos x - 1 + \frac{2x}{\pi} \right) dx$$

$$= 2 \left[\sin x - x + \frac{1}{\pi} x^2 \right]_0^{\pi/2} = 2 \left[\left(1 - \frac{\pi}{2} + \frac{1}{\pi} \cdot \frac{\pi^2}{4}\right) - 0 \right] = 2 \left(1 - \frac{\pi}{2} + \frac{\pi}{4}\right) = 2 - \frac{\pi}{2}$$

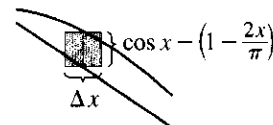
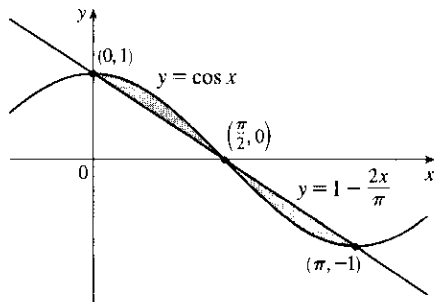

24. For $x > 0$, $x = x^2 - 2 \Rightarrow 0 = x^2 - x - 2 \Rightarrow 0 = (x - 2)(x + 1) \Rightarrow x = 2$. By symmetry,

$$\begin{aligned} \int_{-2}^2 [|x| - (x^2 - 2)] dx &= 2 \int_0^2 [x - (x^2 - 2)] dx = 2 \int_0^2 (x - x^2 + 2) dx = 2 \left[\frac{1}{2}x^2 - \frac{1}{3}x^3 + 2x \right]_0^2 \\ &= 2 \left(2 - \frac{8}{3} + 4 \right) = \frac{20}{3} \end{aligned}$$

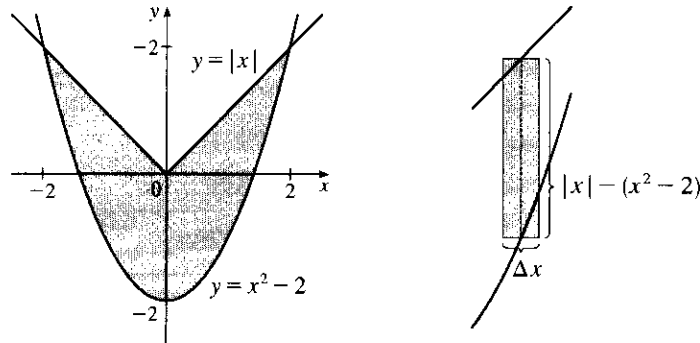

25. Graph the three functions $y = x$, $y = -\frac{1}{2}x$, and $y = -2x + 3$; then determine the points of intersection: $(0, 0)$, $(1, 1)$, and $(2, -1)$.

$$\begin{aligned} A &= \int_0^1 [x - (-\frac{1}{2}x)] dx + \int_1^2 [(3 - 2x) - (-\frac{1}{2}x)] dx = \int_0^1 \frac{3}{2}x dx + \int_1^2 (3 - \frac{3}{2}x) dx \\ &= [\frac{3}{4}x^2]_0^1 + [3x - \frac{3}{4}x^2]_1^2 = (\frac{3}{4} - 0) + (6 - 3) - (3 - \frac{3}{4}) = \frac{3}{2} \end{aligned}$$

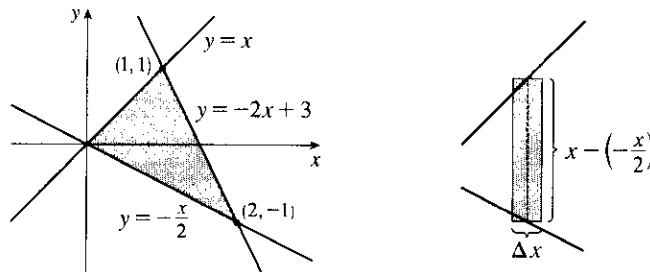

$$\begin{aligned} 26. A &= \int_0^1 [\sin \pi x - (x^2 - x)] dx + \int_1^2 [(x^2 - x) - \sin \pi x] dx \\ &= \left[-\frac{1}{\pi} \cos \pi x - \frac{1}{3}x^3 + \frac{1}{2}x^2 \right]_0^1 + \left[\frac{1}{3}x^3 - \frac{1}{2}x^2 + \frac{1}{\pi} \cos \pi x \right]_1^2 \\ &= \left(\frac{1}{\pi} - \frac{1}{3} + \frac{1}{2} \right) - \left(-\frac{1}{\pi} \right) + \left(\frac{8}{3} - 2 + \frac{1}{\pi} \right) - \left(\frac{1}{3} - \frac{1}{2} - \frac{1}{\pi} \right) \\ &= \frac{4}{\pi} + 1 \end{aligned}$$

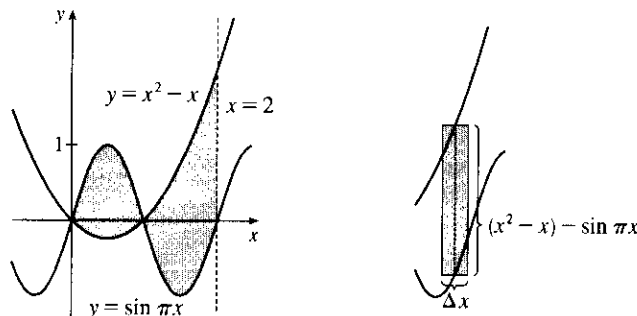

27. An equation of the line through $(0, 0)$ and $(2, 1)$ is $y = \frac{1}{2}x$; through $(0, 0)$ and $(-1, 6)$ is $y = -6x$; through $(2, 1)$ and $(-1, 6)$ is $y = -\frac{5}{3}x + \frac{13}{3}$.

$$\begin{aligned} A &= \int_{-1}^0 \left[\left(-\frac{5}{3}x + \frac{13}{3}\right) - (-6x) \right] dx + \int_0^2 \left[\left(-\frac{5}{3}x + \frac{13}{3}\right) - \frac{1}{2}x \right] dx \\ &= \int_{-1}^0 \left(\frac{13}{3}x + \frac{13}{3} \right) dx + \int_0^2 \left(-\frac{13}{6}x + \frac{13}{3} \right) dx \\ &= \frac{13}{3} \int_{-1}^0 (x+1) dx + \frac{13}{3} \int_0^2 \left(-\frac{1}{2}x + 1\right) dx \\ &= \frac{13}{3} \left[\frac{1}{2}x^2 + x \right]_{-1}^0 + \frac{13}{3} \left[-\frac{1}{4}x^2 + x \right]_0^2 \\ &= \frac{13}{3} \left[0 - \left(\frac{1}{2} - 1\right) \right] + \frac{13}{3} [(-1 + 2) - 0] = \frac{13}{3} \cdot \frac{1}{2} + \frac{13}{3} \cdot 1 = \frac{13}{2} \end{aligned}$$

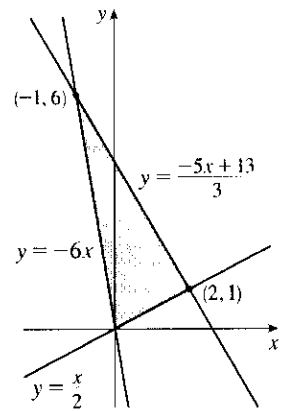

28. $A = \int_0^2 \left[\left(-\frac{4}{5}x + 5\right) - \left(-\frac{7}{2}x + 5\right) \right] dx + \int_2^5 \left[\left(-\frac{4}{5}x + 5\right) - (x - 4) \right] dx$

$$\begin{aligned} &= \int_0^2 \frac{27}{10}x dx + \int_2^5 \left(-\frac{9}{5}x + 9\right) dx \\ &= \left[\frac{27}{20}x^2 \right]_0^2 + \left[-\frac{9}{10}x^2 + 9x \right]_2^5 \\ &= \left(\frac{27}{5} - 0 \right) + \left(-\frac{45}{2} + 45 \right) - \left(-\frac{18}{5} + 18 \right) = \frac{27}{2} \end{aligned}$$

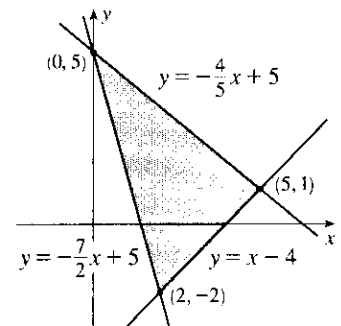

29. $A = \int_{-1}^1 |x^3 - x| dx$

$$\begin{aligned} &= 2 \int_0^1 (x - x^3) dx \quad \text{[by symmetry]} \\ &= 2 \left[\frac{1}{2}x^2 - \frac{1}{4}x^4 \right]_0^1 \\ &= 2 \left(\frac{1}{2} - \frac{1}{4} \right) = \frac{1}{2} \end{aligned}$$

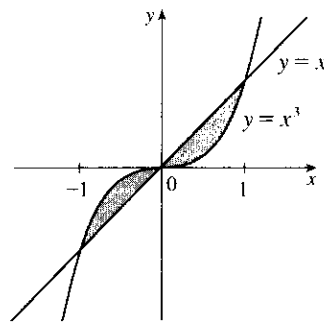

30. The curves intersect when $\sqrt{x+2} = x \Rightarrow x+2 = x^2 \Rightarrow x^2 - x - 2 = 0 \Rightarrow (x-2)(x+1) = 0 \Rightarrow x = -1$ or 2 . $[-1$ is extraneous]

$$\begin{aligned} A &= \int_0^4 |\sqrt{x+2} - x| dx \\ &= \int_0^2 (\sqrt{x+2} - x) dx + \int_2^4 (x - \sqrt{x+2}) dx \\ &= \left[\frac{2}{3}(x+2)^{3/2} - \frac{1}{2}x^2 \right]_0^2 + \left[\frac{1}{2}x^2 - \frac{2}{3}(x+2)^{3/2} \right]_2^4 \\ &= \left(\frac{16}{3} - 2 \right) - \left(\frac{2}{3}(2\sqrt{2}) - 0 \right) + \left(8 - \frac{2}{3}(6\sqrt{6}) \right) - \left(2 - \frac{16}{3} \right) \\ &= 4 + \frac{32}{3} - \frac{4}{3}\sqrt{2} - 4\sqrt{6} = \frac{44}{3} - 4\sqrt{6} - \frac{4}{3}\sqrt{2} \end{aligned}$$

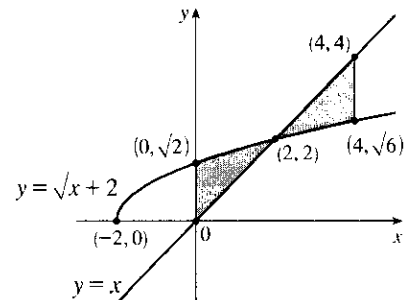

31. Let $f(x) = \cos^2\left(\frac{\pi x}{4}\right) - \sin^2\left(\frac{\pi x}{4}\right)$ and $\Delta x = \frac{1-0}{4}$.

The shaded area is given by

$$\begin{aligned} A &= \int_0^1 f(x) dx \approx M_4 \\ &= \frac{1}{4} \left[f\left(\frac{1}{8}\right) + f\left(\frac{3}{8}\right) + f\left(\frac{5}{8}\right) + f\left(\frac{7}{8}\right) \right] \\ &\approx 0.6407 \end{aligned}$$

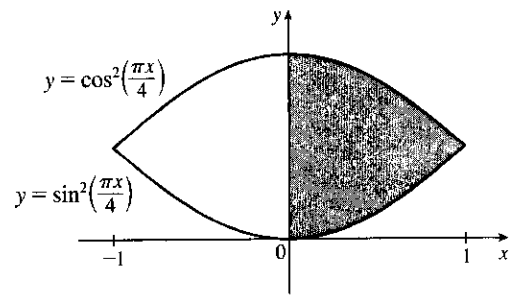

32. The curves intersect when $\sqrt[3]{16-x^3} = x \Rightarrow$

$$16 - x^3 = x^3 \Rightarrow 2x^3 = 16 \Rightarrow x^3 = 8 \Rightarrow x = 2.$$

Let $f(x) = \sqrt[3]{16-x^3} - x$ and $\Delta x = \frac{2-0}{4}$.

The shaded area is given by

$$\begin{aligned} A &= \int_0^2 f(x) dx \approx M_4 \\ &= \frac{2}{4} \left[f\left(\frac{1}{4}\right) + f\left(\frac{3}{4}\right) + f\left(\frac{5}{4}\right) + f\left(\frac{7}{4}\right) \right] \\ &\approx 2.8144 \end{aligned}$$

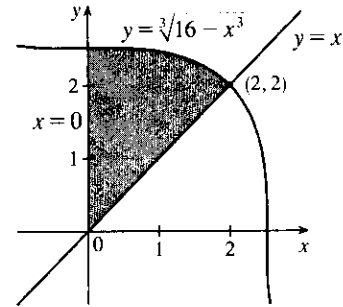

33.

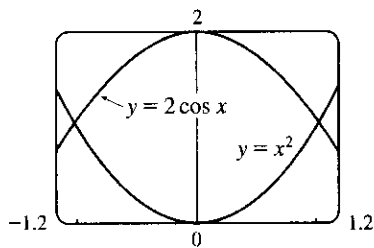

From the graph, we see that the curves intersect at $x = \pm a \approx \pm 1.02$, with $2 \cos x > x^2$ on $(-a, a)$. So the area of the region bounded by the curves is

$$\begin{aligned} A &= \int_{-a}^a (2 \cos x - x^2) dx = 2 \int_0^a (2 \cos x - x^2) dx \\ &= 2 \left[2 \sin x - \frac{1}{3} x^3 \right]_0^a \approx 2.70 \end{aligned}$$

34.

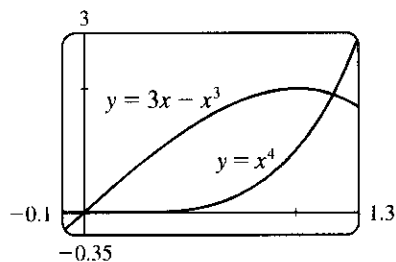

From the graph, we see that the curves intersect at $x = 0$ and at $x = a \approx 1.17$, with $3x - x^3 > x^4$ on $(0, a)$. So the area of the region bounded by the curves is

$$\begin{aligned} A &= \int_0^a [(3x - x^3) - x^4] dx = \left[\frac{3}{2} x^2 - \frac{1}{4} x^4 - \frac{1}{5} x^5 \right]_0^a \\ &\approx 1.15 \end{aligned}$$

35.

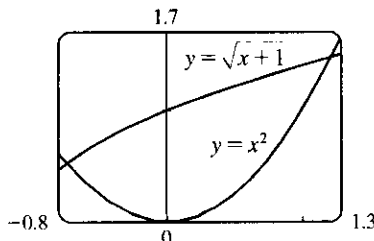

From the graph, we see that the curves intersect at $x = a \approx -0.72$ and at $x = b \approx 1.22$, with $\sqrt{x+1} > x^2$ on (a, b) . So the area between the curves is

$$\begin{aligned} A &= \int_a^b (\sqrt{x+1} - x^2) dx = \left[\frac{2}{3} (x+1)^{3/2} - \frac{1}{3} x^3 \right]_a^b \\ &\approx 1.38 \end{aligned}$$

36.

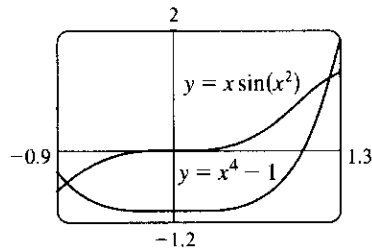

From the graph, we see that the curves intersect at $x = a \approx -0.83$ and $x = b \approx 1.22$, with $x \sin(x^2) > x^4 - 1$ on (a, b) . So the area of the region bounded by the curves is

$$A = \int_a^b [x \sin(x^2) - (x^4 - 1)] dx$$

$$= \left[-\frac{1}{2} \cos(x^2) - \frac{1}{5} x^5 + x\right]_a^b \approx 1.78$$

37. As the figure illustrates, the curves $y = x$ and $y = x^5 - 6x^3 + 4x$ enclose a four-part region symmetric about the origin (since $x^5 - 6x^3 + 4x$ and x are odd functions of x). The curves intersect at values of x where

$x^5 - 6x^3 + 4x = x$; that is, where $x(x^4 - 6x^2 + 3) = 0$. That happens at $x = 0$ and where

$$x^2 = \frac{6 \pm \sqrt{36 - 12}}{2} = 3 \pm \sqrt{6}; \text{ that is, at } x = -\sqrt{3 + \sqrt{6}}, -\sqrt{3 - \sqrt{6}}, 0, \sqrt{3 - \sqrt{6}}, \text{ and } \sqrt{3 + \sqrt{6}}.$$

The exact area is

$$2 \int_0^{\sqrt{3+\sqrt{6}}} |(x^5 - 6x^3 + 4x) - x| dx = 2 \int_0^{\sqrt{3+\sqrt{6}}} |x^5 - 6x^3 + 3x| dx$$

$$= 2 \int_0^{\sqrt{3-\sqrt{6}}} (x^5 - 6x^3 + 3x) dx + 2 \int_{\sqrt{3-\sqrt{6}}}^{\sqrt{3+\sqrt{6}}} (-x^5 + 6x^3 - 3x) dx$$

$$\stackrel{\text{CAS}}{=} 12\sqrt{6} - 9$$

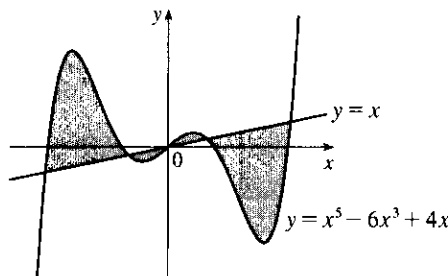

38. The inequality $x \geq 2y^2$ describes the region that lies on, or to the right of, the parabola $x = 2y^2$. The inequality $x \leq 1 - |y|$ describes the region

that lies on, or to the left of, the curve $x = 1 - |y| = \begin{cases} 1 - y & \text{if } y \geq 0 \\ 1 + y & \text{if } y < 0 \end{cases}$.

So the given region is the shaded region that lies between the curves.

The graphs of $x = 1 - y$ and $x = 2y^2$ intersect when $1 - y = 2y^2 \Leftrightarrow 2y^2 + y - 1 = 0 \Leftrightarrow (2y - 1)(y + 1) = 0 \Rightarrow y = \frac{1}{2}$ (for $y \geq 0$).

By symmetry,

$$A = 2 \int_0^{1/2} [(1 - y) - 2y^2] dy = 2 \left[-\frac{2}{3}y^3 - \frac{1}{2}y^2 + y\right]_0^{1/2} = 2 \left[\left(-\frac{1}{12} - \frac{1}{8} + \frac{1}{2}\right) - 0\right] = 2\left(\frac{7}{24}\right) = \frac{7}{12}.$$

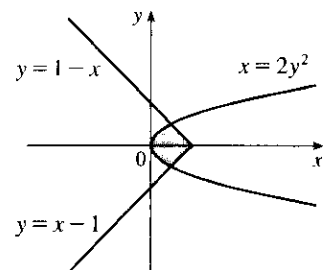

39. 1 second = $\frac{1}{3600}$ hour, so 10 s = $\frac{1}{360}$ h. With the given data, we can take $n = 5$ to use the Midpoint Rule.

$$\Delta t = \frac{1/360 - 0}{5} = \frac{1}{1800}, \text{ so}$$

$$\begin{aligned} \text{distance}_{\text{Kelly}} - \text{distance}_{\text{Chris}} &= \int_0^{1/360} v_K dt - \int_0^{1/360} v_C dt = \int_0^{1/360} (v_K - v_C) dt \\ &\approx M_5 = \frac{1}{1800} [(v_K - v_C)(1) + (v_K - v_C)(3) + (v_K - v_C)(5) \\ &\quad + (v_K - v_C)(7) + (v_K - v_C)(9)] \\ &= \frac{1}{1800} [(22 - 20) + (52 - 46) + (71 - 62) + (86 - 75) + (98 - 86)] \\ &= \frac{1}{1800} (2 + 6 + 9 + 11 + 12) = \frac{1}{1800} (40) = \frac{1}{45} \text{ mile, or } 117\frac{1}{3} \text{ feet} \end{aligned}$$

40. If x = distance from left end of pool and $w = w(x)$ = width at x , then the Midpoint Rule with $n = 4$ and

$$\Delta x = \frac{b - a}{n} = \frac{8 \cdot 2 - 0}{4} = 4 \text{ gives Area} = \int_0^{16} w dx \approx 4(6.2 + 6.8 + 5.0 + 4.8) = 4(22.8) = 91.2 \text{ m}^2.$$

41. We know that the area under curve A between $t = 0$ and $t = x$ is $\int_0^x v_A(t) dt = s_A(x)$, where $v_A(t)$ is the velocity of car A and s_A is its displacement. Similarly, the area under curve B between $t = 0$ and $t = x$ is

$$\int_0^x v_B(t) dt = s_B(x).$$

- (a) After one minute, the area under curve A is greater than the area under curve B . So car A is ahead after one minute.
- (b) The area of the shaded region has numerical value $s_A(1) - s_B(1)$, which is the distance by which A is ahead of B after 1 minute.
- (c) After two minutes, car B is traveling faster than car A and has gained some ground, but the area under curve A from $t = 0$ to $t = 2$ is still greater than the corresponding area for curve B , so car A is still ahead.
- (d) From the graph, it appears that the area between curves A and B for $0 \leq t \leq 1$ (when car A is going faster), which corresponds to the distance by which car A is ahead, seems to be about 3 squares. Therefore, the cars will be side by side at the time x where the area between the curves for $1 \leq t \leq x$ (when car B is going faster) is the same as the area for $0 \leq t \leq 1$. From the graph, it appears that this time is $x \approx 2.2$. So the cars are side by side when $t \approx 2.2$ minutes.
42. The area under $R'(x)$ from $x = 50$ to $x = 100$ represents the change in revenue, and the area under $C'(x)$ from $x = 50$ to $x = 100$ represents the change in cost. The shaded region represents the difference between these two values; that is, the increase in profit as the production level increases from 50 units to 100 units. We use the Midpoint Rule with $n = 5$ and $\Delta x = 10$:

$$\begin{aligned} M_5 &= \Delta x \{ [R'(55) - C'(55)] + [R'(65) - C'(65)] + [R'(75) - C'(75)] \\ &\quad + [R'(85) - C'(85)] + [R'(95) - C'(95)] \} \\ &\approx 10(2.40 - 0.85 + 2.20 - 0.90 + 2.00 - 1.00 + 1.80 - 1.10 + 1.70 - 1.20) \\ &= 10(5.05) = 50.5 \text{ thousand dollars} \end{aligned}$$

Using M_1 would give us $50(2 - 1) = 50$ thousand dollars.

43.

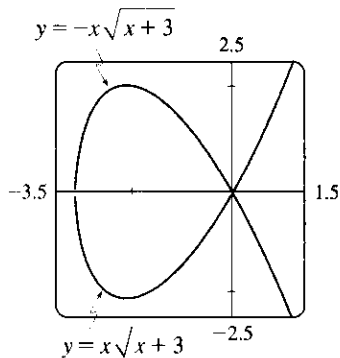

To graph this function, we must first express it as a combination of explicit functions of y ; namely, $y = \pm x\sqrt{x+3}$. We can see from the graph that the loop extends from $x = -3$ to $x = 0$, and that by symmetry, the area we seek is just twice the area under the top half of the curve on this interval, the equation of the top half being $y = x\sqrt{x+3}$. So the area is $A = 2 \int_{-3}^0 (-x\sqrt{x+3}) dx$. We substitute $u = x + 3$, so $du = dx$ and the limits change to 0 and 3, and we get

$$\begin{aligned} A &= -2 \int_0^3 [(u-3)\sqrt{u}] du = -2 \int_0^3 (u^{3/2} - 3u^{1/2}) du \\ &= -2 \left[\frac{2}{5} u^{5/2} - 2u^{3/2} \right]_0^3 = -2 \left[\frac{2}{5} (3^2\sqrt{3}) - 2(3\sqrt{3}) \right] = \frac{24}{5} \sqrt{3} \end{aligned}$$

44.

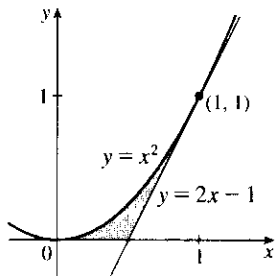

We start by finding the equation of the tangent line to $y = x^2$ at the point $(1, 1)$: $y' = 2x$, so the slope of the tangent is $2(1) = 2$, and its equation is $y - 1 = 2(x - 1)$, or $y = 2x - 1$. We would need two integrals to integrate with respect to x , but only one to integrate with respect to y .

$$\begin{aligned} A &= \int_0^1 \left[\frac{1}{2}(y+1) - \sqrt{y} \right] dy = \left[\frac{1}{4}y^2 + \frac{1}{2}y - \frac{2}{3}y^{3/2} \right]_0^1 \\ &= \frac{1}{4} + \frac{1}{2} - \frac{2}{3} = \frac{1}{12} \end{aligned}$$

45.

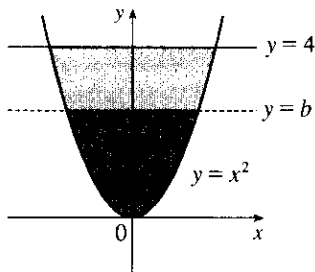

By the symmetry of the problem, we consider only the first quadrant, where $y = x^2 \Rightarrow x = \sqrt{y}$. We are looking for a number b such that $\int_0^b \sqrt{y} dy = \int_b^4 \sqrt{y} dy \Rightarrow \frac{2}{3} [y^{3/2}]_0^b = \frac{2}{3} [y^{3/2}]_b^4 \Rightarrow b^{3/2} = 4^{3/2} - b^{3/2} \Rightarrow 2b^{3/2} = 8 \Rightarrow b^{3/2} = 4 \Rightarrow b = 4^{2/3} \approx 2.52$.

$$\begin{aligned} 46. \text{ (a) We want to choose } a \text{ so that } \int_1^a \frac{1}{x^2} dx &= \int_a^4 \frac{1}{x^2} dx \Rightarrow \left[\frac{-1}{x} \right]_1^a = \left[\frac{-1}{x} \right]_a^4 \Rightarrow -\frac{1}{a} + 1 = -\frac{1}{4} + \frac{1}{a} \\ &\Rightarrow \frac{5}{4} = \frac{2}{a} \Rightarrow a = \frac{8}{5}. \end{aligned}$$

(b) The area under the curve $y = 1/x^2$ from $x = 1$ to $x = 4$ is $\frac{3}{4}$ [take $a = 4$ in the first integral in part (a)]. Now the line $y = b$ must intersect the curve $x = 1/\sqrt{y}$ and not the line $x = 4$, since the area under the line $y = 1/4^2$ from $x = 1$ to $x = 4$ is only $\frac{3}{16}$, which is less than half of $\frac{3}{4}$. We want to choose b so that the upper area in the

diagram is half of the total area under the curve $y = \frac{1}{x^2}$ from $x = 1$ to $x = 4$. This implies that

$$\int_b^1 (1/\sqrt{y} - 1) dy = \frac{1}{2} \cdot \frac{3}{4} \Rightarrow [2\sqrt{y} - y]_b^1 = \frac{3}{8} \Rightarrow$$

$$1 - 2\sqrt{b} + b = \frac{3}{8} \Rightarrow b - 2\sqrt{b} + \frac{5}{8} = 0. \text{ Letting } c = \sqrt{b}, \text{ we get}$$

$$c^2 - 2c + \frac{5}{8} = 0 \Rightarrow 8c^2 - 16c + 5 = 0. \text{ Thus,}$$

$$c = \frac{16 \pm \sqrt{256 - 160}}{16} = 1 \pm \frac{\sqrt{6}}{4}. \text{ But } c = \sqrt{b} < 1 \Rightarrow c = 1 - \frac{\sqrt{6}}{4} \Rightarrow$$

$$b = c^2 = 1 + \frac{3}{8} - \frac{\sqrt{6}}{2} = \frac{1}{8}(11 - 4\sqrt{6}) \approx 0.1503.$$

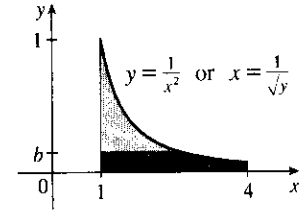

47. We first assume that $c > 0$, since c can be replaced by $-c$ in both equations without changing the graphs, and if $c = 0$ the curves do not enclose a region. We see from the graph that the enclosed area A lies between $x = -c$ and $x = c$, and by symmetry, it is equal to four times the area in the first quadrant.

The enclosed area is

$$A = 4 \int_0^c (c^2 - x^2) dx = 4 \left[c^2 x - \frac{1}{3} x^3 \right]_0^c$$

$$= 4 \left(c^3 - \frac{1}{3} c^3 \right) = 4 \left(\frac{2}{3} c^3 \right) = \frac{8}{3} c^3$$

So $A = 576 \Leftrightarrow \frac{8}{3} c^3 = 576 \Leftrightarrow c^3 = 216 \Leftrightarrow c = \sqrt[3]{216} = 6.$

Note that $c = -6$ is another solution, since the graphs are the same.

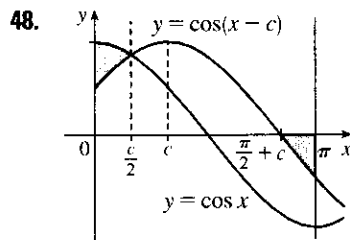
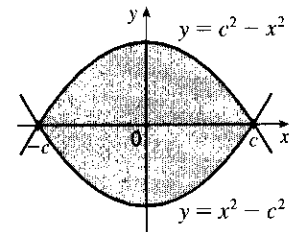

It appears from the diagram that the curves $y = \cos x$ and $y = \cos(x - c)$ intersect halfway between 0 and c , namely, when $x = c/2$. We can verify that this is indeed true by noting that $\cos(c/2 - c) = \cos(-c/2) = \cos(c/2)$. The point where $\cos(x - c)$ crosses the x -axis is $x = \frac{\pi}{2} + c$. So we require that $\int_0^{c/2} [\cos x - \cos(x - c)] dx = - \int_{\pi/2+c}^{\pi} \cos(x - c) dx$ (the negative sign on the RHS is needed since the second area is beneath the x -axis) \Leftrightarrow

$$[\sin x - \sin(x - c)]_0^{c/2} = - [\sin(x - c)]_{\pi/2+c}^{\pi} \Rightarrow$$

$$[\sin(c/2) - \sin(-c/2)] - [-\sin(-c)] = -\sin(\pi - c) + \sin\left[\left(\frac{\pi}{2} + c\right) - c\right] \Leftrightarrow$$

$2 \sin(c/2) - \sin c = -\sin c + 1$. [Here we have used the oddness of the sine function, and the fact that

$$\sin(\pi - c) = \sin c]. \text{ So } 2 \sin(c/2) = 1 \Leftrightarrow \sin(c/2) = \frac{1}{2} \Leftrightarrow c/2 = \frac{\pi}{6} \Leftrightarrow c = \frac{\pi}{3}.$$

49. $A = \int_1^2 \left(\frac{1}{x} - \frac{1}{x^2} \right) dx = \left[\ln x + \frac{1}{x} \right]_1^2$

$$= \left(\ln 2 + \frac{1}{2} \right) - (\ln 1 + 1)$$

$$= \ln 2 - \frac{1}{2} \approx 0.19$$

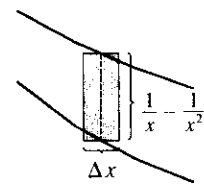
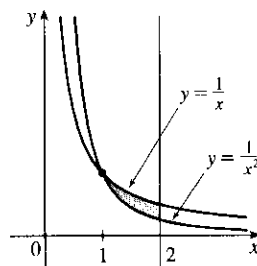

$$\begin{aligned}
 50. A &= \int_0^{\pi/2} (e^x - \sin x) dx \\
 &= [e^x + \cos x]_0^{\pi/2} \\
 &= (e^{\pi/2} + 0) - (1 + 1) \\
 &= e^{\pi/2} - 2
 \end{aligned}$$

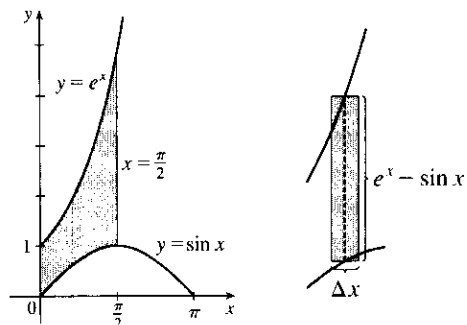

$$\begin{aligned}
 51. \text{ The curves intersect when } x^2 = \frac{2}{x^2 + 1} &\Leftrightarrow x^4 + x^2 = 2 \Leftrightarrow x^4 + x^2 - 2 = 0 \Leftrightarrow \\
 (x^2 + 2)(x^2 - 1) = 0 &\Leftrightarrow x^2 = 1 \Leftrightarrow x = \pm 1.
 \end{aligned}$$

$$\begin{aligned}
 A &= \int_{-1}^1 \left(\frac{2}{x^2 + 1} - x^2 \right) dx \\
 &= 2 \int_0^1 \left(\frac{2}{x^2 + 1} - x^2 \right) dx \\
 &= 2 \left[2 \tan^{-1} x - \frac{1}{3} x^3 \right]_0^1 = 2 \left(2 \cdot \frac{\pi}{4} - \frac{1}{3} \right) \\
 &= \pi - \frac{2}{3} \approx 2.47
 \end{aligned}$$

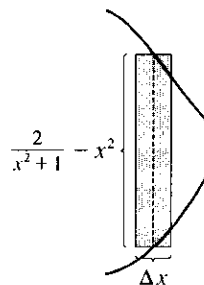
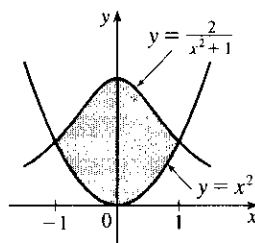

52. The curve and the line will determine a region when they intersect at two or more points. So we solve the equation

$$\begin{aligned}
 x/(x^2 + 1) = mx &\Rightarrow x = x(mx^2 + m) \Rightarrow \\
 x(mx^2 + m) - x &= 0 \Rightarrow x(mx^2 + m - 1) = 0 \Rightarrow \\
 x = 0 \text{ or } mx^2 + m - 1 &= 0 \Rightarrow x = 0 \text{ or } x^2 = \frac{1 - m}{m} \Rightarrow
 \end{aligned}$$

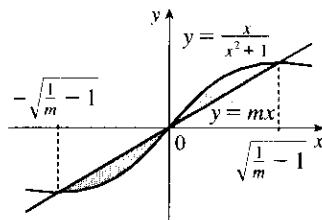

$x = 0$ or $x = \pm \sqrt{\frac{1}{m} - 1}$. Note that if $m = 1$, this has only the solution $x = 0$, and no region is determined. But if $1/m - 1 > 0 \Leftrightarrow 1/m > 1 \Leftrightarrow 0 < m < 1$, then there are two solutions. [Another way of seeing this is to observe that the slope of the tangent to $y = x/(x^2 + 1)$ at the origin is $y' = 1$ and therefore we must have $0 < m < 1$.] Note that we cannot just integrate between the positive and negative roots, since the curve and the line cross at the origin. Since mx and $x/(x^2 + 1)$ are both odd functions, the total area is twice the area between the curves on the interval $[0, \sqrt{1/m - 1}]$. So the total area enclosed is

$$\begin{aligned}
 2 \int_0^{\sqrt{1/m-1}} \left[\frac{x}{x^2 + 1} - mx \right] dx &= 2 \left[\frac{1}{2} \ln(x^2 + 1) - \frac{1}{2} mx^2 \right]_0^{\sqrt{1/m-1}} \\
 &= [\ln(1/m - 1 + 1) - m(1/m - 1)] - (\ln 1 - 0) \\
 &= \ln(1/m) - 1 + m = m - \ln m - 1
 \end{aligned}$$

6.2 Volumes

1. A cross-section is circular with radius x^2 , so its area is $A(x) = \pi(x^2)^2$.

$$V = \int_0^1 A(x) dx = \int_0^1 \pi(x^2)^2 dx = \pi \int_0^1 x^4 dx = \pi \left[\frac{1}{5} x^5 \right]_0^1 = \frac{\pi}{5}$$

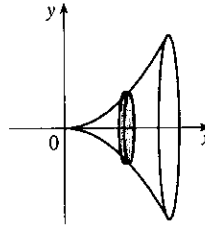
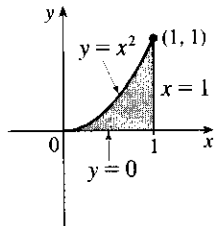

2. $x + 2y = 2 \Leftrightarrow y = 1 - \frac{1}{2}x$, so a cross-section is circular with radius $1 - \frac{1}{2}x$, and its area is

$$A(x) = \pi\left(1 - \frac{1}{2}x\right)^2.$$

$$\begin{aligned} V &= \int_0^2 \pi y^2 dx = \pi \int_0^2 \left(1 - \frac{1}{2}x\right)^2 dx = \pi \int_0^2 \left(1 - x + \frac{1}{4}x^2\right) dx = \pi \left[x - \frac{1}{2}x^2 + \frac{1}{12}x^3 \right]_0^2 \\ &= \pi\left(2 - 2 + \frac{2}{3}\right) = \frac{2}{3}\pi \end{aligned}$$

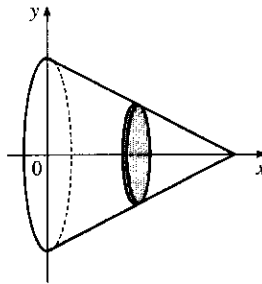
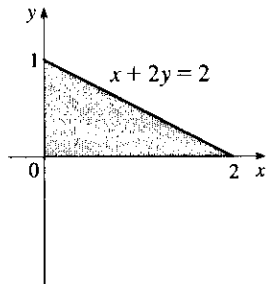

3. A cross-section is a disk with radius $1/x$, so its area is $A(x) = \pi(1/x)^2$.

$$V = \int_1^2 A(x) dx = \int_1^2 \pi \left(\frac{1}{x}\right)^2 dx = \pi \int_1^2 \frac{1}{x^2} dx = \pi \left[-\frac{1}{x} \right]_1^2 = \pi \left[-\frac{1}{2} - (-1) \right] = \frac{\pi}{2}$$

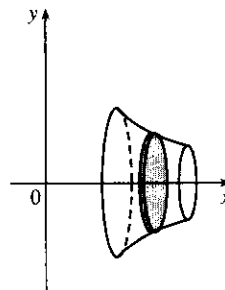
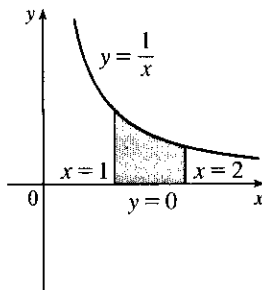

4. A cross-section is circular with radius $\sqrt{x-1}$, so its area is $A(x) = \pi(\sqrt{x-1})^2 = \pi(x-1)$.

$$V = \int_2^5 A(x) dx = \int_2^5 \pi(x-1) dx = \pi \left[\frac{1}{2}x^2 - x \right]_2^5 = \pi \left(\frac{25}{2} - 5 - \frac{4}{2} + 2 \right) = \frac{15}{2}\pi$$

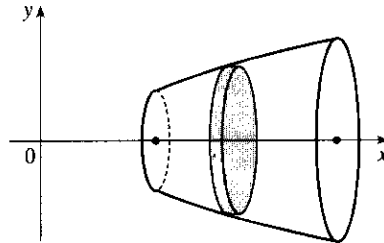
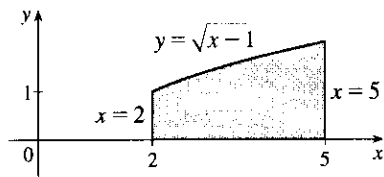

5. A cross-section is a disk with radius \sqrt{y} , so its area is $A(y) = \pi(\sqrt{y})^2$.

$$V = \int_0^4 A(y) dy = \int_0^4 \pi(\sqrt{y})^2 dy = \pi \int_0^4 y dy = \pi \left[\frac{1}{2}y^2 \right]_0^4 = 8\pi$$

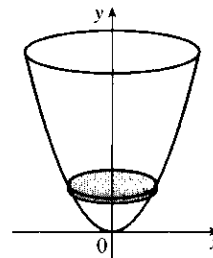
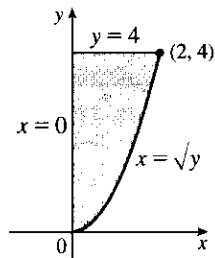

6. A cross-section is a disk with radius $y - y^2$, so its area is $A(y) = \pi(y - y^2)^2$.

$$\begin{aligned} V &= \int_0^1 A(y) dy = \int_0^1 \pi(y - y^2)^2 dy = \pi \int_0^1 (y^4 - 2y^3 + y^2) dy = \pi \left[\frac{1}{5}y^5 - \frac{1}{2}y^4 + \frac{1}{3}y^3 \right]_0^1 \\ &= \pi \left(\frac{1}{5} - \frac{1}{2} + \frac{1}{3} \right) = \frac{\pi}{30} \end{aligned}$$

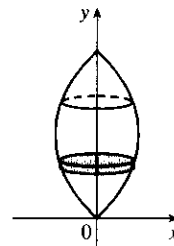
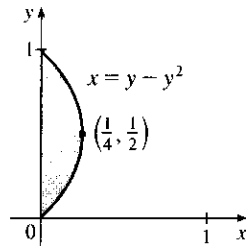

7. A cross-section is a washer (annulus) with inner radius x^2 and outer radius \sqrt{x} , so its area is

$$A(x) = \pi(\sqrt{x})^2 - \pi(x^2)^2 = \pi(x - x^4).$$

$$V = \int_0^1 A(x) dx = \pi \int_0^1 (x - x^4) dx = \pi \left[\frac{1}{2}x^2 - \frac{1}{5}x^5 \right]_0^1 = \pi \left(\frac{1}{2} - \frac{1}{5} \right) = \frac{3\pi}{10}$$

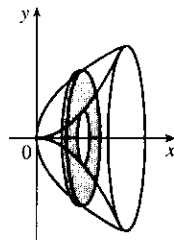
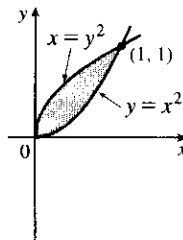

8. A cross-section is a washer with inner radius 1 and outer radius $\sec x$, so its area is

$$A(x) = \pi(\sec x)^2 - \pi(1)^2 = \pi(\sec^2 x - 1).$$

$$V = \int_{-1}^1 A(x) dx = \int_{-1}^1 \pi(\sec^2 x - 1) dx = 2\pi \int_0^1 (\sec^2 x - 1) dx = 2\pi[\tan x - x]_0^1 = 2\pi(\tan 1 - 1) \approx 3.5023$$

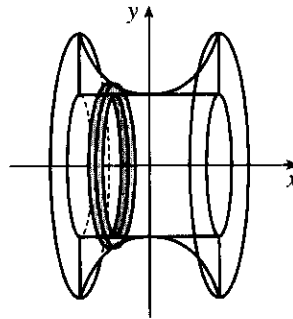
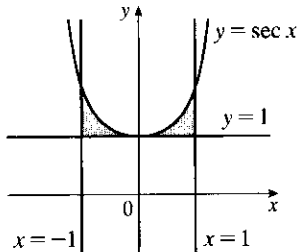

9. A cross-section is a washer with inner radius y^2 and outer radius $2y$, so its area is

$$A(y) = \pi(2y)^2 - \pi(y^2)^2 = \pi(4y^2 - y^4).$$

$$V = \int_0^2 A(y) dy = \pi \int_0^2 (4y^2 - y^4) dy = \pi \left[\frac{4}{3}y^3 - \frac{1}{5}y^5 \right]_0^2 = \pi \left(\frac{32}{3} - \frac{32}{5} \right) = \frac{64\pi}{15}$$

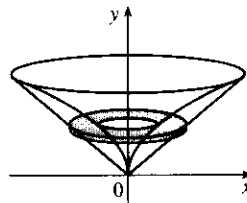
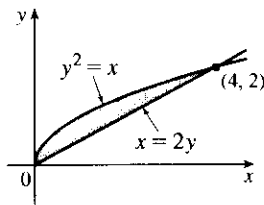

10. $y = x^{2/3} \Leftrightarrow x = y^{3/2}$, so a cross-section is a washer with inner radius $y^{3/2}$ and outer radius 1, and its area is

$$A(y) = \pi(1)^2 - \pi(y^{3/2})^2 = \pi(1 - y^3).$$

$$V = \int_0^1 A(y) dy = \pi \int_0^1 (1 - y^3) dy = \pi \left[y - \frac{1}{4}y^4 \right]_0^1 = \frac{3}{4}\pi$$

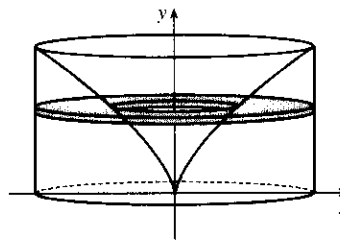
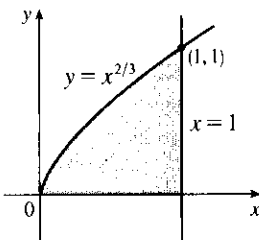

11. A cross-section is a washer with inner radius $1 - \sqrt{x}$ and outer radius $1 - x$, so its area is

$$A(x) = \pi(1 - x)^2 - \pi(1 - \sqrt{x})^2 = \pi[(1 - 2x + x^2) - (1 - 2\sqrt{x} + x)] = \pi(-3x + x^2 + 2\sqrt{x}).$$

$$\begin{aligned} V &= \int_0^1 A(x) dx = \pi \int_0^1 (-3x + x^2 + 2\sqrt{x}) dx \\ &= \pi \left[-\frac{3}{2}x^2 + \frac{1}{3}x^3 + \frac{4}{3}x^{3/2} \right]_0^1 = \pi \left(-\frac{3}{2} + \frac{5}{3} \right) = \frac{\pi}{6} \end{aligned}$$

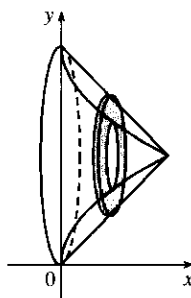
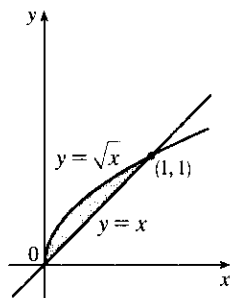

12. A cross-section is circular with radius $4 - x^2$, so its area is $A(x) = \pi(4 - x^2)^2 = \pi(16 - 8x^2 + x^4)$.

$$\begin{aligned} V &= \int_{-2}^2 A(x) dx = 2 \int_0^2 A(x) dx = 2\pi \int_0^2 (16 - 8x^2 + x^4) dx = 2\pi \left[16x - \frac{8}{3}x^3 + \frac{1}{5}x^5 \right]_0^2 \\ &= 2\pi \left(32 - \frac{64}{3} + \frac{32}{5} \right) = 64\pi \left(1 - \frac{2}{3} + \frac{1}{5} \right) = 64\pi \cdot \frac{8}{15} = \frac{512\pi}{15} \end{aligned}$$

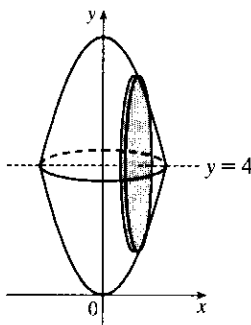
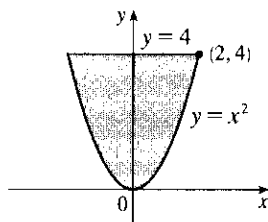

13. A cross-section is an annulus with inner radius $2 - 1$ and outer radius $2 - x^4$, so its area is

$$A(x) = \pi(2 - x^4)^2 - \pi(2 - 1)^2 = \pi(3 - 4x^4 + x^8).$$

$$\begin{aligned} V &= \int_{-1}^1 A(x) dx = 2 \int_0^1 A(x) dx = 2\pi \int_0^1 (3 - 4x^4 + x^8) dx = 2\pi \left[3x - \frac{4}{5}x^5 + \frac{1}{9}x^9 \right]_0^1 \\ &= 2\pi \left(3 - \frac{4}{5} + \frac{1}{9} \right) = \frac{208}{45}\pi \end{aligned}$$

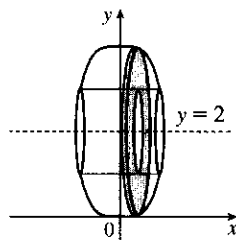
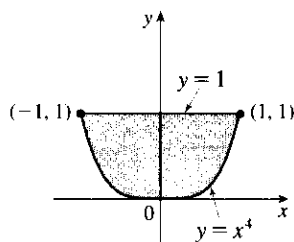

$$\begin{aligned}
 14. V &= \int_1^3 \pi \left\{ \left[\frac{1}{x^2} - (-1) \right]^2 - [0 - (-1)]^2 \right\} dx = \pi \int_1^3 \left[\left(\frac{1}{x^2} + 1 \right)^2 - 1^2 \right] dx = \pi \int_1^3 \left(\frac{1}{x^4} + \frac{2}{x^2} \right) dx \\
 &= \pi \left[-\frac{1}{3x^3} - \frac{2}{x} \right]_1^3 = \pi \left[\left(-\frac{1}{81} - \frac{2}{3} \right) - \left(-\frac{1}{3} - 2 \right) \right] = \frac{134\pi}{81}
 \end{aligned}$$

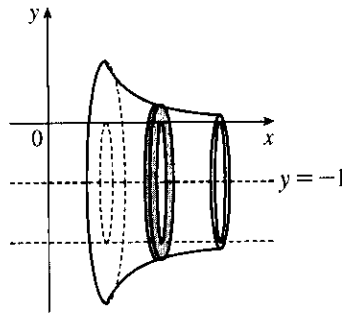
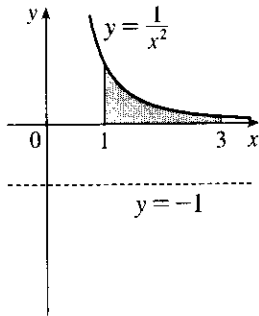

$$\begin{aligned}
 15. V &= \int_{-1}^1 \pi (1 - y^2)^2 dy = 2 \int_0^1 \pi (1 - y^2)^2 dy = 2\pi \int_0^1 (1 - 2y^2 + y^4) dy \\
 &= 2\pi \left[y - \frac{2}{3}y^3 + \frac{1}{5}y^5 \right]_0^1 = 2\pi \cdot \frac{8}{15} = \frac{16}{15}\pi
 \end{aligned}$$

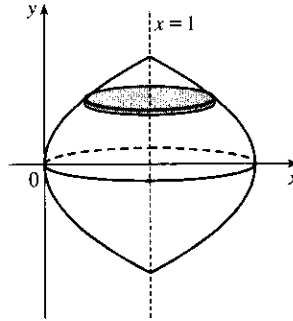
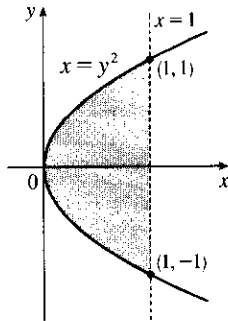

16. $y = \sqrt{x} \Rightarrow x = y^2$, so the outer radius is $2 - y^2$.

$$\begin{aligned}
 V &= \int_0^1 \pi \left[(2 - y^2)^2 - (2 - y)^2 \right] dy = \pi \int_0^1 \left[(4 - 4y^2 + y^4) - (4 - 4y + y^2) \right] dy \\
 &= \pi \int_0^1 (y^4 - 5y^2 + 4y) dy = \pi \left[\frac{1}{5}y^5 - \frac{5}{3}y^3 + 2y^2 \right]_0^1 = \pi \left(\frac{1}{5} - \frac{5}{3} + 2 \right) = \frac{8}{15}\pi
 \end{aligned}$$

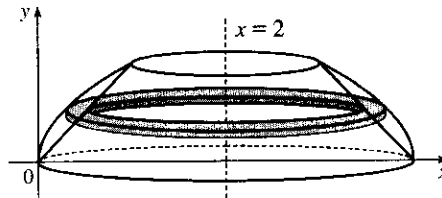
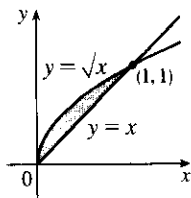

17. $y = x^2 \Rightarrow x = \sqrt{y}$ for $x \geq 0$. The outer radius is the distance from $x = -1$ to $x = \sqrt{y}$ and the inner radius is the distance from $x = -1$ to $x = y^2$.

$$\begin{aligned} V &= \int_0^1 \pi \left\{ [\sqrt{y} - (-1)]^2 - [y^2 - (-1)]^2 \right\} dy = \pi \int_0^1 \left[(\sqrt{y} + 1)^2 - (y^2 + 1)^2 \right] dy \\ &= \pi \int_0^1 (y + 2\sqrt{y} + 1 - y^4 - 2y^2 - 1) dy = \pi \int_0^1 (y + 2\sqrt{y} - y^4 - 2y^2) dy \\ &= \pi \left[\frac{1}{2}y^2 + \frac{4}{3}y^{3/2} - \frac{1}{5}y^5 - \frac{2}{3}y^3 \right]_0^1 = \pi \left(\frac{1}{2} + \frac{4}{3} - \frac{1}{5} - \frac{2}{3} \right) = \frac{29}{30}\pi \end{aligned}$$

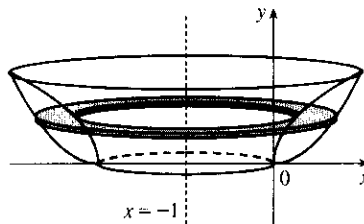
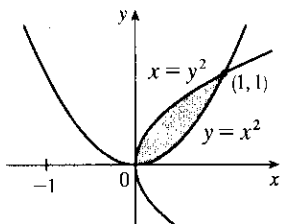

18. For $0 \leq y < 2$, a cross-section is an annulus with inner radius $2 - 1$ and outer radius $4 - 1$, the area of which is $A_1(y) = \pi(4 - 1)^2 - \pi(2 - 1)^2$. For $2 \leq y \leq 4$, a cross-section is an annulus with inner radius $y - 1$ and outer radius $4 - 1$, the area of which is $A_2(y) = \pi(4 - 1)^2 - \pi(y - 1)^2$.

$$\begin{aligned} V &= \int_0^4 A(y) dy = \pi \int_0^2 [(4 - 1)^2 - (2 - 1)^2] dy + \pi \int_2^4 [(4 - 1)^2 - (y - 1)^2] dy \\ &= \pi [8y]_0^2 + \pi \int_2^4 (8 + 2y - y^2) dy = 16\pi + \pi \left[8y + y^2 - \frac{1}{3}y^3 \right]_2^4 \\ &= 16\pi + \pi \left[(32 + 16 - \frac{64}{3}) - (16 + 4 - \frac{8}{3}) \right] = \frac{76}{3}\pi \end{aligned}$$

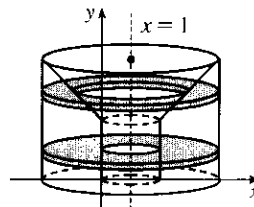
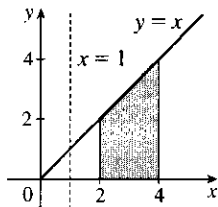

19. \mathcal{R}_1 about OA (the line $y = 0$): $V = \int_0^1 A(x) dx = \int_0^1 \pi(x^3)^2 dx = \pi \int_0^1 x^6 dx = \pi \left[\frac{1}{7}x^7 \right]_0^1 = \frac{\pi}{7}$

20. \mathcal{R}_1 about OC (the line $x = 0$):

$$V = \int_0^1 A(y) dy = \int_0^1 \left[\pi(1)^2 - \pi(\sqrt[3]{y})^2 \right] dy = \pi \int_0^1 (1 - y^{2/3}) dy = \pi \left[y - \frac{3}{5}y^{5/3} \right]_0^1 = \pi \left(1 - \frac{3}{5} \right) = \frac{2\pi}{5}$$

21. \mathcal{R}_1 about AB (the line $x = 1$):

$$\begin{aligned} V &= \int_0^1 A(y) dy = \int_0^1 \pi(1 - \sqrt[3]{y})^2 dy = \pi \int_0^1 (1 - 2y^{1/3} + y^{2/3}) dy \\ &= \pi \left[y - \frac{3}{2}y^{4/3} + \frac{3}{5}y^{5/3} \right]_0^1 = \pi \left(1 - \frac{3}{2} + \frac{3}{5} \right) = \frac{\pi}{10} \end{aligned}$$

22. \mathcal{R}_1 about BC (the line $y = 1$):

$$\begin{aligned} V &= \int_0^1 A(x) dx = \int_0^1 [\pi(1)^2 - \pi(1 - x^3)^2] dx = \pi \int_0^1 [1 - (1 - 2x^3 + x^6)] dx \\ &= \pi \int_0^1 (2x^3 - x^6) dx = \pi \left[\frac{1}{2}x^4 - \frac{1}{7}x^7 \right]_0^1 = \pi \left(\frac{1}{2} - \frac{1}{7} \right) = \frac{5\pi}{14} \end{aligned}$$

23. \mathcal{R}_2 about OA (the line $y = 0$):

$$V = \int_0^1 A(x) dx = \int_0^1 [\pi(1)^2 - \pi(\sqrt{x})^2] dx = \pi \int_0^1 (1 - x) dx = \pi \left[x - \frac{1}{2}x^2 \right]_0^1 = \pi \left(1 - \frac{1}{2} \right) = \frac{\pi}{2}$$

24. \mathcal{R}_2 about OC (the line $x = 0$): $V = \int_0^1 A(y) dy = \int_0^1 \pi(y^2)^2 dy = \pi \int_0^1 y^4 dy = \pi \left[\frac{1}{5} y^5 \right]_0^1 = \frac{\pi}{5}$

25. \mathcal{R}_2 about AB (the line $x = 1$):

$$V = \int_0^1 A(y) dy = \int_0^1 [\pi(1)^2 - \pi(1 - y^2)^2] dy = \pi \int_0^1 [1 - (1 - 2y^2 + y^4)] dy$$

$$= \pi \int_0^1 (2y^2 - y^4) dy = \pi \left[\frac{2}{3} y^3 - \frac{1}{5} y^5 \right]_0^1 = \pi \left(\frac{2}{3} - \frac{1}{5} \right) = \frac{7\pi}{15}$$

26. \mathcal{R}_2 about BC (the line $y = 1$):

$$V = \int_0^1 A(x) dx = \int_0^1 \pi(1 - \sqrt{x})^2 dx = \pi \int_0^1 (1 - 2x^{1/2} + x) dx$$

$$= \pi \left[x - \frac{4}{3} x^{3/2} + \frac{1}{2} x^2 \right]_0^1 = \pi \left(1 - \frac{4}{3} + \frac{1}{2} \right) = \frac{\pi}{6}$$

27. \mathcal{R}_3 about OA (the line $y = 0$):

$$V = \int_0^1 A(x) dx = \int_0^1 [\pi(\sqrt{x})^2 - \pi(x^3)^2] dx = \pi \int_0^1 (x - x^6) dx = \pi \left[\frac{1}{2} x^2 - \frac{1}{7} x^7 \right]_0^1 = \pi \left(\frac{1}{2} - \frac{1}{7} \right) = \frac{5\pi}{14}.$$

Note: Let $\mathcal{R} = \mathcal{R}_1 + \mathcal{R}_2 + \mathcal{R}_3$. If we rotate \mathcal{R} about any of the segments OA , OC , AB , or BC , we obtain a right circular cylinder of height 1 and radius 1. Its volume is $\pi r^2 h = \pi(1)^2 \cdot 1 = \pi$. As a check for Exercises 19, 23, and 27, we can add the answers, and that sum must equal π . Thus, $\frac{\pi}{7} + \frac{\pi}{2} + \frac{5\pi}{14} = \left(\frac{2+7+5}{14} \right) \pi = \pi$.

28. \mathcal{R}_3 about OC (the line $x = 0$):

$$V = \int_0^1 A(y) dy = \int_0^1 [\pi(\sqrt[3]{y})^2 - \pi(y^2)^2] dy = \pi \int_0^1 (y^{2/3} - y^4) dy$$

$$= \pi \left[\frac{3}{5} y^{5/3} - \frac{1}{5} y^5 \right]_0^1 = \pi \left(\frac{3}{5} - \frac{1}{5} \right) = \frac{2\pi}{5}$$

Note: See the note in Exercise 27. For Exercises 20, 24, and 28, we have $\frac{2\pi}{5} + \frac{\pi}{5} + \frac{2\pi}{5} = \pi$.

29. \mathcal{R}_3 about AB (the line $x = 1$):

$$V = \int_0^1 A(y) dy = \int_0^1 [\pi(1 - y^2)^2 - \pi(1 - \sqrt[3]{y})^2] dy = \pi \int_0^1 [(1 - 2y^2 + y^4) - (1 - 2y^{1/3} + y^{2/3})] dy$$

$$= \pi \int_0^1 (-2y^2 + y^4 + 2y^{1/3} - y^{2/3}) dy = \pi \left[-\frac{2}{3} y^3 + \frac{1}{5} y^5 + \frac{3}{2} y^{4/3} - \frac{3}{5} y^{5/3} \right]_0^1$$

$$= \pi \left(-\frac{2}{3} + \frac{1}{5} + \frac{3}{2} - \frac{3}{5} \right) = \frac{13\pi}{30}$$

Note: See the note in Exercise 27. For Exercises 21, 25, and 29, we have $\frac{\pi}{10} + \frac{7\pi}{15} + \frac{13\pi}{30} = \left(\frac{3+14+13}{30} \right) \pi = \pi$.

30. \mathcal{R}_3 about BC (the line $y = 1$):

$$V = \int_0^1 A(x) dx = \int_0^1 [\pi(1 - x^3)^2 - \pi(1 - \sqrt{x})^2] dx$$

$$= \pi \int_0^1 [(1 - 2x^3 + x^6) - (1 - 2x^{1/2} + x)] dx = \pi \int_0^1 (-2x^3 + x^6 + 2x^{1/2} - x) dx$$

$$= \pi \left[-\frac{1}{2} x^4 + \frac{1}{7} x^7 + \frac{4}{3} x^{3/2} - \frac{1}{2} x^2 \right]_0^1 = \pi \left(-\frac{1}{2} + \frac{1}{7} + \frac{4}{3} - \frac{1}{2} \right) = \frac{10\pi}{21}$$

Note: See the note in Exercise 27. For Exercises 22, 26, and 30, we have $\frac{5\pi}{14} + \frac{\pi}{6} + \frac{10\pi}{21} = \left(\frac{15+7+20}{42} \right) \pi = \pi$.

31. $V = \pi \int_0^{\pi/4} (1 - \tan^3 x)^2 dx$

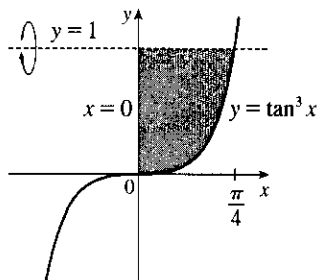

32. $y = (x - 2)^4$ and $8x - y = 16$ intersect when

$$\begin{aligned} (x - 2)^4 &= 8x - 16 = 8(x - 2) \Leftrightarrow \\ (x - 2)^4 - 8(x - 2) &= 0 \Leftrightarrow (x - 2)[(x - 2)^3 - 8] = 0 \\ \Leftrightarrow x - 2 = 0 \text{ or } x - 2 = 2 &\Leftrightarrow x = 2 \text{ or } 4. \\ y = (x - 2)^4 &\Rightarrow x - 2 = \pm \sqrt[4]{y} \Rightarrow x = 2 + \sqrt[4]{y} \\ [\text{since } x \geq 2], 8x - y = 16 &\Rightarrow 8x = y + 16 \Rightarrow \\ x &= \frac{1}{8}y + 2. \end{aligned}$$

$$V = \pi \int_0^{16} \left\{ \left[10 - \left(\frac{1}{8}y + 2 \right) \right]^2 - \left[10 - \left(2 + \sqrt[4]{y} \right) \right]^2 \right\} dy$$

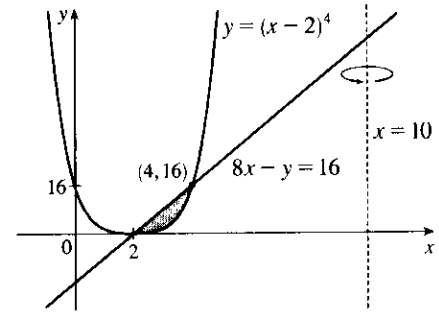

33. $V = \pi \int_0^\pi [(1 - 0)^2 - (1 - \sin x)^2] dx$
 $= \pi \int_0^\pi [1^2 - (1 - \sin x)^2] dx$

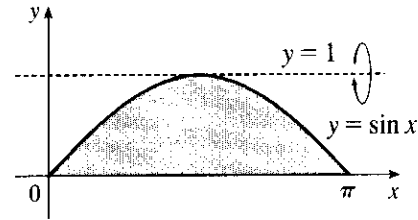

34. $V = \pi \int_0^\pi [(\sin x + 2)^2 - 2^2] dx$

35. $V = \pi \int_{-\sqrt{8}}^{\sqrt{8}} \left\{ [3 - (-2)]^2 - [\sqrt{y^2 + 1} - (-2)]^2 \right\} dy$
 $= \pi \int_{-2\sqrt{2}}^{2\sqrt{2}} [5^2 - (\sqrt{1 + y^2} + 2)^2] dy$

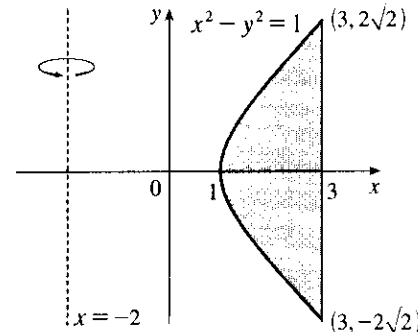

36. Solve the equations for x : $(y - 1)^2 = 4 - x \Leftrightarrow x = 4 - (y - 1)^2$ and $2x + 3y = 6 \Leftrightarrow x = 3 - \frac{3}{2}y$.
 The points of intersection of the two curves are $(3, 0)$ and $(-\frac{9}{4}, \frac{7}{2})$. Therefore,

$$\begin{aligned} V &= \pi \int_0^{7/2} \left\{ [4 - (y - 1)^2 - (-5)]^2 - \left[3 - \frac{3}{2}y - (-5) \right]^2 \right\} dy \\ &= \pi \int_0^{7/2} \left\{ [9 - (y - 1)^2]^2 - \left(8 - \frac{3}{2}y \right)^2 \right\} dy \end{aligned}$$

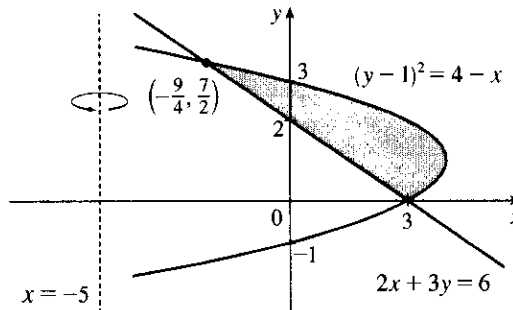

37. We see from the graph in Exercise 6.1.35 that the x -coordinates of the points of intersection are $x = a \approx -0.72$ and $x = b \approx 1.22$, with $\sqrt{x+1} > x^2$ on the interval (a, b) , so the volume of revolution is

$$\pi \int_a^b [(\sqrt{x+1})^2 - (x^2)^2] dx = \pi \int_a^b (x+1-x^4) dx = \pi \left[\frac{1}{2}x^2 + x - \frac{1}{5}x^5 \right]_a^b \approx 5.80.$$

38. We see from the graph in Exercise 6.1.34 that the x -coordinates of the points of intersection are $x = 0$ and $x = a \approx 1.17$, with $3x - x^3 > x^4$ on the interval $(0, a)$, so the volume of revolution is

$$\begin{aligned} \pi \int_0^a [(3x - x^3)^2 - (x^4)^2] dx &= \pi \int_0^a (9x^2 - 6x^4 + x^6 - x^8) dx \\ &= \pi \left[3x^3 - \frac{6}{5}x^5 + \frac{1}{7}x^7 - \frac{1}{9}x^9 \right]_0^a \approx 6.74 \end{aligned}$$

39. $V = \pi \int_0^\pi \{ [\sin^2 x - (-1)]^2 - [0 - (-1)]^2 \} dx$
 $\stackrel{\text{CAS}}{=} \frac{11}{8}\pi^2$

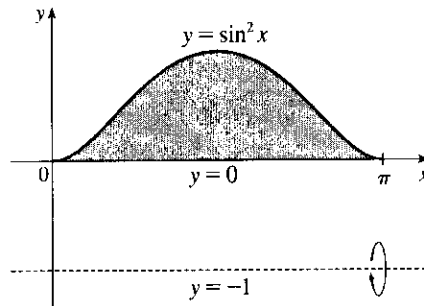

40. $V = \pi \int_0^2 \{ [2 - (x^2 - 2x)]^2 - [2 - x \cos(\pi x/4)]^2 \} dx$
 $\stackrel{\text{CAS}}{=} \frac{4(19\pi^2 + 120\pi - 210)}{15\pi}$

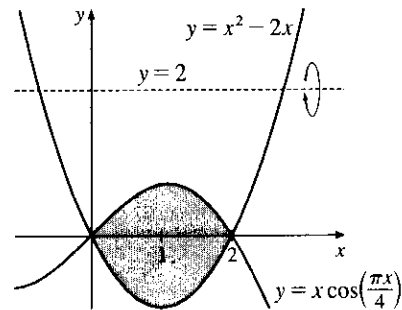

41. $\pi \int_0^{\pi/2} \cos^2 x dx$ describes the volume of the solid obtained by rotating the region $\mathcal{R} = \{(x, y) \mid 0 \leq x \leq \frac{\pi}{2}, 0 \leq y \leq \cos x\}$ of the xy -plane about the x -axis.
42. $\pi \int_2^5 y dy = \pi \int_2^5 (\sqrt{y})^2 dy$ describes the volume of the solid obtained by rotating the region $\mathcal{R} = \{(x, y) \mid 2 \leq y \leq 5, 0 \leq x \leq \sqrt{y}\}$ of the xy -plane about the y -axis.
43. $\pi \int_0^1 (y^4 - y^8) dy = \pi \int_0^1 [(y^2)^2 - (y^4)^2] dy$ describes the volume of the solid obtained by rotating the region $\mathcal{R} = \{(x, y) \mid 0 \leq y \leq 1, y^4 \leq x \leq y^2\}$ of the xy -plane about the y -axis.
44. $\pi \int_0^{\pi/2} [(1 + \cos x)^2 - 1^2] dx$ describes the volume of the solid obtained by rotating the region $\mathcal{R} = \{(x, y) \mid 0 \leq x \leq \frac{\pi}{2}, 1 \leq y \leq 1 + \cos x\}$ of the xy -plane about the x -axis.
Or: The solid could be obtained by rotating the region $\mathcal{R}' = \{(x, y) \mid 0 \leq x \leq \frac{\pi}{2}, 0 \leq y \leq \cos x\}$ about the line $y = -1$.
45. There are 10 subintervals over the 15-cm length, so we'll use $n = 10/2 = 5$ for the Midpoint Rule.
 $V = \int_0^{15} A(x) dx \approx M_5 = \frac{15-0}{5} [A(1.5) + A(4.5) + A(7.5) + A(10.5) + A(13.5)]$
 $= 3(18 + 79 + 106 + 128 + 39) = 3 \cdot 370 = 1110 \text{ cm}^3$

$$46. V = \int_0^{10} A(x) dx \approx M_5 = \frac{10-0}{5}[A(1) + A(3) + A(5) + A(7) + A(9)] \\ = 2(0.65 + 0.61 + 0.59 + 0.55 + 0.50) = 2(2.90) = 5.80 \text{ m}^3$$

47. We'll form a right circular cone with height h and base radius r by revolving the line $y = \frac{r}{h}x$ about the x -axis.

$$V = \pi \int_0^h \left(\frac{r}{h}x\right)^2 dx = \pi \int_0^h \frac{r^2}{h^2} x^2 dx = \pi \frac{r^2}{h^2} \left[\frac{1}{3}x^3\right]_0^h \\ = \pi \frac{r^2}{h^2} \left(\frac{1}{3}h^3\right) = \frac{1}{3}\pi r^2 h$$

Another solution: Revolve $x = -\frac{r}{h}y + r$ about the y -axis.

$$V = \pi \int_0^h \left(-\frac{r}{h}y + r\right)^2 dy = \pi \int_0^h \left[\frac{r^2}{h^2}y^2 - \frac{2r^2}{h}y + r^2\right] dy \\ = \pi \left[\frac{r^2}{3h^2}y^3 - \frac{r^2}{h}y^2 + r^2y\right]_0^h = \pi \left(\frac{1}{3}r^2h - r^2h + r^2h\right) = \frac{1}{3}\pi r^2 h$$

* Or use substitution with $u = r - \frac{r}{h}y$ and $du = -\frac{r}{h}dy$ to get

$$\pi \int_r^0 u^2 \left(-\frac{h}{r} du\right) = -\pi \frac{h}{r} \left[\frac{1}{3}u^3\right]_r^0 = -\pi \frac{h}{r} \left(-\frac{1}{3}r^3\right) = \frac{1}{3}\pi r^2 h.$$

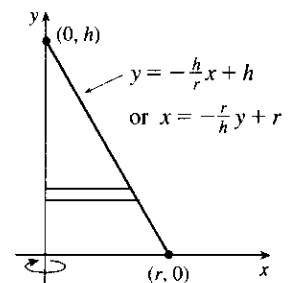
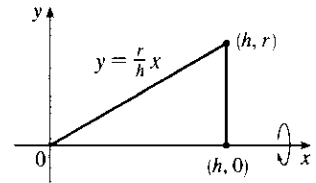

$$48. V = \pi \int_0^h \left(R - \frac{R-r}{h}y\right)^2 dy \\ = \pi \int_0^h \left[R^2 - \frac{2R(R-r)}{h}y + \left(\frac{R-r}{h}\right)^2 y^2\right] dy \\ = \pi \left[R^2y - \frac{R(R-r)}{h}y^2 + \frac{1}{3}\left(\frac{R-r}{h}\right)^2 y^3\right]_0^h \\ = \pi \left[R^2h - R(R-r)h + \frac{1}{3}(R-r)^2 h\right] \\ = \frac{1}{3}\pi h [3Rr + (R^2 - 2Rr + r^2)] = \frac{1}{3}\pi h (R^2 + Rr + r^2)$$

Another solution: $\frac{H}{R} = \frac{H-h}{r}$ by similar triangles. Therefore,

$$Hr = HR - hR \Rightarrow hR = H(R-r) \Rightarrow H = \frac{hR}{R-r}. \text{ Now}$$

$$V = \frac{1}{3}\pi R^2 H - \frac{1}{3}\pi r^2 (H-h) \quad [\text{by Exercise 47}] \\ = \frac{1}{3}\pi R^2 \frac{hR}{R-r} - \frac{1}{3}\pi r^2 \frac{rh}{R-r} \quad \left[H-h = \frac{rH}{R} = \frac{rhR}{R(R-r)}\right] \\ = \frac{1}{3}\pi h \frac{R^3 - r^3}{R-r} = \frac{1}{3}\pi h (R^2 + Rr + r^2) \\ = \frac{1}{3} \left[\pi R^2 + \pi r^2 + \sqrt{(\pi R^2)(\pi r^2)}\right] h = \frac{1}{3}(A_1 + A_2 + \sqrt{A_1 A_2}) h$$

where A_1 and A_2 are the areas of the bases of the frustum. (See Exercise 50 for a related result.)

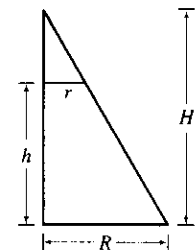
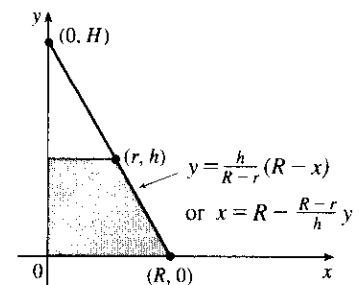

$$49. x^2 + y^2 = r^2 \Leftrightarrow x^2 = r^2 - y^2$$

$$\begin{aligned} V &= \pi \int_{r-h}^r (r^2 - y^2) dy = \pi \left[r^2 y - \frac{y^3}{3} \right]_{r-h}^r \\ &= \pi \left\{ \left[r^3 - \frac{r^3}{3} \right] - \left[r^2(r-h) - \frac{(r-h)^3}{3} \right] \right\} \\ &= \pi \left\{ \frac{2}{3} r^3 - \frac{1}{3} (r-h) [3r^2 - (r-h)^2] \right\} \\ &= \frac{1}{3} \pi \left\{ 2r^3 - (r-h) [3r^2 - (r^2 - 2rh + h^2)] \right\} \\ &= \frac{1}{3} \pi \left\{ 2r^3 - (r-h) [2r^2 + 2rh - h^2] \right\} \\ &= \frac{1}{3} \pi (2r^3 - 2r^2h - 2r^2h + rh^2 + 2r^2h + 2rh^2 - h^3) \\ &= \frac{1}{3} \pi (3rh^2 - h^3) = \frac{1}{3} \pi h^2 (3r - h), \text{ or, equivalently, } \pi h^2 \left(r - \frac{h}{3} \right) \end{aligned}$$

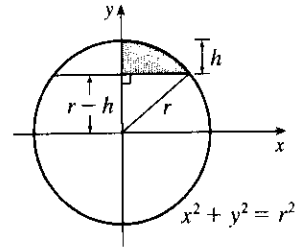

$$50. \text{ An equation of the line is } x = \frac{\Delta x}{\Delta y} y + (\text{x-intercept}) = \frac{a/2 - b/2}{h - 0} y + \frac{b}{2} = \frac{a-b}{2h} y + \frac{b}{2}.$$

$$\begin{aligned} V &= \int_0^h A(y) dy = \int_0^h (2x)^2 dy \\ &= \int_0^h \left[2 \left(\frac{a-b}{2h} y + \frac{b}{2} \right) \right]^2 dy = \int_0^h \left[\frac{a-b}{h} y + b \right]^2 dy \\ &= \int_0^h \left[\frac{(a-b)^2}{h^2} y^2 + \frac{2b(a-b)}{h} y + b^2 \right] dy \\ &= \left[\frac{(a-b)^2}{3h^2} y^3 + \frac{b(a-b)}{h} y^2 + b^2 y \right]_0^h \\ &= \frac{1}{3} (a-b)^2 h + b(a-b)h + b^2 h = \frac{1}{3} (a^2 - 2ab + b^2 + 3ab) h \\ &= \frac{1}{3} (a^2 + ab + b^2) h \end{aligned}$$

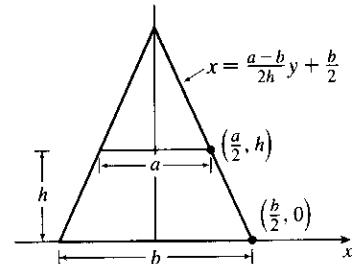

[Note that this can be written as $\frac{1}{3} (A_1 + A_2 + \sqrt{A_1 A_2}) h$, as in Exercise 48.]

If $a = b$, we get a rectangular solid with volume $b^2 h$. If $a = 0$, we get a square pyramid with volume $\frac{1}{3} b^2 h$.

$$51. \text{ For a cross-section at height } y, \text{ we see from similar triangles that } \frac{\alpha/2}{b/2} = \frac{h-y}{h}, \text{ so } \alpha = b \left(1 - \frac{y}{h} \right).$$

Similarly, for cross-sections having $2b$ as their base and β replacing α , $\beta = 2b \left(1 - \frac{y}{h} \right)$. So

$$\begin{aligned} V &= \int_0^h A(y) dy = \int_0^h \left[b \left(1 - \frac{y}{h} \right) \right] \left[2b \left(1 - \frac{y}{h} \right) \right] dy \\ &= \int_0^h 2b^2 \left(1 - \frac{y}{h} \right)^2 dy = 2b^2 \int_0^h \left(1 - \frac{2y}{h} + \frac{y^2}{h^2} \right) dy \\ &= 2b^2 \left[y - \frac{y^2}{h} + \frac{y^3}{3h^2} \right]_0^h = 2b^2 \left[h - h + \frac{1}{3} h \right] \\ &= \frac{2}{3} b^2 h \quad \left[= \frac{1}{3} B h \text{ where } B \text{ is the area of the base, as with any pyramid.} \right] \end{aligned}$$

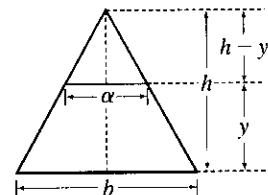

52. Consider the triangle consisting of two vertices of the base and the center of the base. This triangle is similar to the corresponding triangle at a height y , so $a/b = \alpha/\beta \Rightarrow \alpha = a\beta/b$. Also by similar triangles, $b/h = \beta/(h - y) \Rightarrow \beta = b(h - y)/h$. These two equations imply that $\alpha = a(1 - y/h)$, and since the cross-section is an equilateral triangle, it has area

$$A(y) = \frac{1}{2} \cdot \alpha \cdot \frac{\sqrt{3}}{2} \alpha = \frac{a^2(1 - y/h)^2}{4} \sqrt{3}, \text{ so}$$

$$\begin{aligned} V &= \int_0^h A(y) dy = \frac{a^2\sqrt{3}}{4} \int_0^h \left(1 - \frac{y}{h}\right)^2 dy \\ &= \frac{a^2\sqrt{3}}{4} \left[-\frac{h}{3} \left(1 - \frac{y}{h}\right)^3 \right]_0^h = -\frac{\sqrt{3}}{12} a^2 h (-1) = \frac{\sqrt{3}}{12} a^2 h \end{aligned}$$

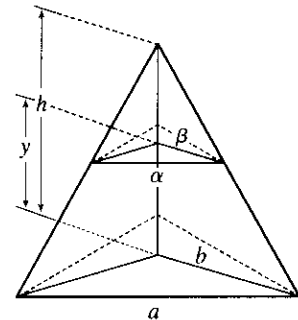

53. A cross-section at height z is a triangle similar to the base, so we'll multiply the legs of the base triangle, 3 and 4, by a proportionality factor of $(5 - z)/5$. Thus, the triangle at height z has area

$$A(z) = \frac{1}{2} \cdot 3 \left(\frac{5 - z}{5}\right) \cdot 4 \left(\frac{5 - z}{5}\right) = 6 \left(1 - \frac{z}{5}\right)^2, \text{ so}$$

$$\begin{aligned} V &= \int_0^5 A(z) dz = 6 \int_0^5 \left(1 - z/5\right)^2 dz \\ &= 6 \int_1^0 u^2 (-5 du) \quad [u = 1 - z/5, du = -\frac{1}{5} dz] \\ &= -30 \left[\frac{1}{3} u^3 \right]_1^0 = -30 \left(-\frac{1}{3}\right) = 10 \text{ cm}^3 \end{aligned}$$

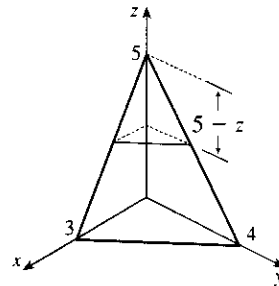

54. A cross-section is shaded in the diagram.

$$A(x) = (2y)^2 = (2\sqrt{r^2 - x^2})^2, \text{ so}$$

$$\begin{aligned} V &= \int_{-r}^r A(x) dx = 2 \int_0^r 4(r^2 - x^2) dx \\ &= 8 \left[r^2 x - \frac{1}{3} x^3 \right]_0^r \\ &= 8 \left(\frac{2}{3} r^3 \right) = \frac{16}{3} r^3 \end{aligned}$$

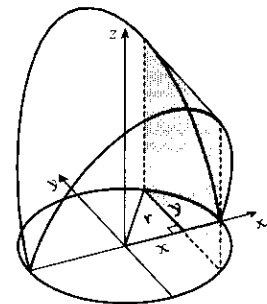

55. If l is a leg of the isosceles right triangle and $2y$ is the hypotenuse, then $l^2 + l^2 = (2y)^2 \Rightarrow 2l^2 = 4y^2 \Rightarrow l^2 = 2y^2$.

$$\begin{aligned} V &= \int_{-2}^2 A(x) dx = 2 \int_0^2 A(x) dx = 2 \int_0^2 \frac{1}{2} (l)(l) dx = 2 \int_0^2 y^2 dx \\ &= 2 \int_0^2 \frac{1}{4} (36 - 9x^2) dx = \frac{9}{2} \int_0^2 (4 - x^2) dx \\ &= \frac{9}{2} \left[4x - \frac{1}{3} x^3 \right]_0^2 = \frac{9}{2} \left(8 - \frac{8}{3} \right) = 24 \end{aligned}$$

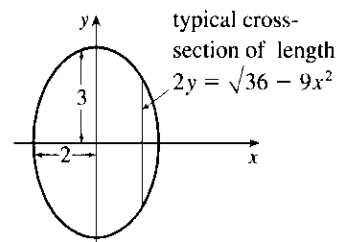

56. The cross-section of the base corresponding to the coordinate y has length $2x = 2\sqrt{y}$. The corresponding equilateral triangle with side s has area $A(y) = s^2 \left(\frac{\sqrt{3}}{4}\right) = (2x)^2 \left(\frac{\sqrt{3}}{4}\right) = (2\sqrt{y})^2 \left(\frac{\sqrt{3}}{4}\right) = y\sqrt{3}$. Therefore, $V = \int_0^1 A(y) dy = \int_0^1 y\sqrt{3} dy = \sqrt{3} \left[\frac{1}{2}y^2\right]_0^1 = \frac{\sqrt{3}}{2}$.

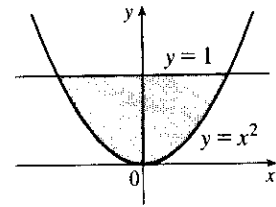

57. The cross-section of the base corresponding to the coordinate y has length $2x = 2\sqrt{y}$. The square has area $A(y) = (2\sqrt{y})^2 = 4y$, so $V = \int_0^1 A(y) dy = \int_0^1 4y dy = [2y^2]_0^1 = 2$.

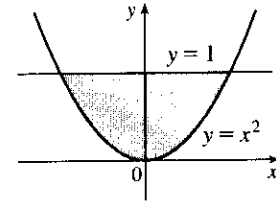

58. A typical cross-section perpendicular to the y -axis in the base has length $\ell(y) = 3 - \frac{3}{2}y$. This length is the diameter of a cross-sectional semicircle in S , so

$$\begin{aligned} V &= \int_0^2 A(y) dy = \int_0^2 \frac{\pi}{2} \left[\frac{\ell(y)}{2} \right]^2 dy = \frac{\pi}{8} \int_0^2 \left(3 - \frac{3}{2}y \right)^2 dy \\ &= \frac{\pi}{8} \int_3^0 u^2 \left(-\frac{2}{3} du \right) \quad \left[u = 3 - \frac{3}{2}y, du = -\frac{3}{2} dy \right] \\ &= -\frac{\pi}{12} \left[\frac{1}{3} u^3 \right]_3^0 = -\frac{\pi}{12} (-9) = \frac{3\pi}{4} \end{aligned}$$

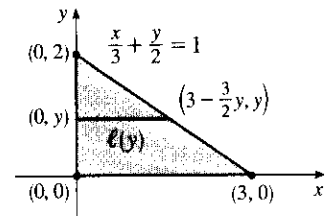

59. A typical cross-section perpendicular to the y -axis in the base has length $\ell(y) = 3 - \frac{3}{2}y$. This length is the leg of an isosceles right triangle, so

$$\begin{aligned} A(y) &= \frac{1}{2} [\ell(y)]^2 \quad \left[\frac{1}{2}bh \text{ with base} = \text{height} \right] \\ &= \frac{1}{2} \left[3 \left(1 - \frac{1}{2}y \right) \right]^2 = \frac{9}{2} \left(1 - \frac{1}{2}y \right)^2 \end{aligned}$$

Thus,

$$\begin{aligned} V &= \int_0^1 A(y) dy = \frac{9}{2} \int_1^0 u^2 (-2 du) \quad \left[u = 1 - \frac{1}{2}y, du = -\frac{1}{2} dy \right] \\ &= -9 \left[\frac{1}{3} u^3 \right]_1^0 = -9 \left(-\frac{1}{3} \right) = 3 \end{aligned}$$

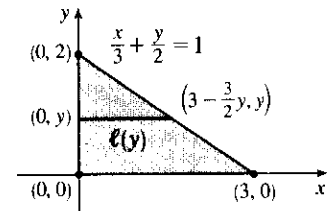

60. (a) $V = \int_{-r}^r A(x) dx = 2 \int_0^r A(x) dx = 2 \int_0^r \frac{1}{2} h(2\sqrt{r^2 - x^2}) dx = 2h \int_0^r \sqrt{r^2 - x^2} dx$

(b) Observe that the integral represents one quarter of the area of a circle of radius r , so $V = 2h \cdot \frac{1}{4} \pi r^2 = \frac{1}{2} \pi h r^2$.

61. (a) The torus is obtained by rotating the circle $(x - R)^2 + y^2 = r^2$ about the y -axis. Solving for x , we see that the right half of the circle is given by $x = R + \sqrt{r^2 - y^2} = f(y)$ and the left half by $x = R - \sqrt{r^2 - y^2} = g(y)$. So

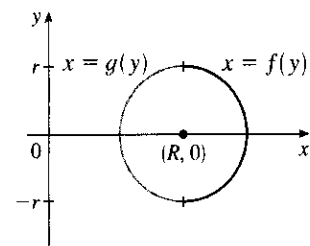

$$\begin{aligned} V &= \pi \int_{-r}^r \{ [f(y)]^2 - [g(y)]^2 \} dy \\ &= 2\pi \int_0^r \left[\left(R^2 + 2R\sqrt{r^2 - y^2} + r^2 - y^2 \right) - \left(R^2 - 2R\sqrt{r^2 - y^2} + r^2 - y^2 \right) \right] dy \\ &= 2\pi \int_0^r 4R\sqrt{r^2 - y^2} dy = 8\pi R \int_0^r \sqrt{r^2 - y^2} dy \end{aligned}$$

- (b) Observe that the integral represents a quarter of the area of a circle with radius r , so $8\pi R \int_0^r \sqrt{r^2 - y^2} dy = 8\pi R \cdot \frac{1}{4}\pi r^2 = 2\pi^2 r^2 R$.

62. The cross-sections perpendicular to the y -axis in Figure 17 are rectangles. The rectangle corresponding to the coordinate y has a base of length $2\sqrt{16 - y^2}$ in the xy -plane and a height of $\frac{1}{\sqrt{3}}y$, since $\angle BAC = 30^\circ$ and $|BC| = \frac{1}{\sqrt{3}}|AB|$. Thus, $A(y) = \frac{2}{\sqrt{3}}y\sqrt{16 - y^2}$ and

$$\begin{aligned} V &= \int_0^4 A(y) dy = \frac{2}{\sqrt{3}} \int_0^4 \sqrt{16 - y^2} y dy \\ &= \frac{2}{\sqrt{3}} \int_{16}^0 u^{1/2} \left(-\frac{1}{2} du\right) \quad [\text{Put } u = 16 - y^2, \text{ so } du = -2y dy] \\ &= \frac{1}{\sqrt{3}} \int_0^{16} u^{1/2} du = \frac{1}{\sqrt{3}} \frac{2}{3} \left[u^{3/2} \right]_0^{16} = \frac{2}{3\sqrt{3}} (64) = \frac{128}{3\sqrt{3}} \end{aligned}$$

63. (a) $\text{Volume}(S_1) = \int_0^h A(z) dz = \text{Volume}(S_2)$ since the cross-sectional area $A(z)$ at height z is the same for both solids.
 (b) By Cavalieri's Principle, the volume of the cylinder in the figure is the same as that of a right circular cylinder with radius r and height h , that is, $\pi r^2 h$.

64. Each cross-section of the solid S in a plane perpendicular to the x -axis is a square (since the edges of the cut lie on the cylinders, which are perpendicular). One-quarter of this square and one-eighth of S are shown. The area of this quarter-square is $|PQ|^2 = r^2 - x^2$. Therefore, $A(x) = 4(r^2 - x^2)$ and the volume of S is

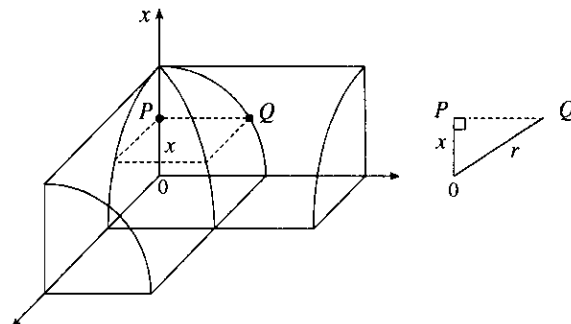

$$\begin{aligned} V &= \int_{-r}^r A(x) dx = 4 \int_{-r}^r (r^2 - x^2) dx \\ &= 8 \int_0^r (r^2 - x^2) dx = 8 \left[r^2 x - \frac{1}{3} x^3 \right]_0^r = \frac{16}{3} r^3 \end{aligned}$$

65. The volume is obtained by rotating the area common to two circles of radius r , as shown. The volume of the right half is

$$\begin{aligned} V_{\text{right}} &= \pi \int_0^{r/2} y^2 dx = \pi \int_0^{r/2} \left[r^2 - \left(\frac{1}{2}r + x \right)^2 \right] dx \\ &= \pi \left[r^2 x - \frac{1}{3} \left(\frac{1}{2}r + x \right)^3 \right]_0^{r/2} = \pi \left[\left(\frac{1}{2}r^3 - \frac{1}{3}r^3 \right) - \left(0 - \frac{1}{24}r^3 \right) \right] = \frac{5}{24}\pi r^3 \end{aligned}$$

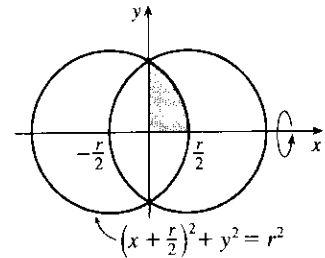

So by symmetry, the total volume is twice this, or $\frac{5}{12}\pi r^3$.

Another solution: We observe that the volume is the twice the volume of a cap of a sphere, so we can use the formula from Exercise 49 with $h = \frac{1}{2}r$: $V = 2 \cdot \frac{1}{3}\pi h^2(3r - h) = \frac{2}{3}\pi \left(\frac{1}{2}r\right)^2(3r - \frac{1}{2}r) = \frac{5}{12}\pi r^3$.

66. We consider two cases: one in which the ball is not completely submerged and the other in which it is.

Case 1: $0 \leq h \leq 10$ The ball will not be completely submerged, and so a cross-section of the water parallel to the surface will be the shaded area shown in the first diagram. We can find the area of the cross-section at height x above the bottom of the bowl by using the Pythagorean Theorem: $R^2 = 15^2 - (15 - x)^2$ and $r^2 = 5^2 - (x - 5)^2$, so $A(x) = \pi(R^2 - r^2) = 20\pi x$. The volume of water when it has depth h is then

$$V(h) = \int_0^h A(x) dx = \int_0^h 20\pi x dx = [10\pi x^2]_0^h = 10\pi h^2 \text{ cm}^3, 0 \leq h \leq 10.$$

Case 2: $10 < h \leq 15$ In this case we can find the volume by simply subtracting the volume displaced by the ball from the total volume inside the bowl underneath the surface of the water. The total volume underneath the surface is just the volume of a cap of the bowl,

so we use the formula from Exercise 49:

$$V_{\text{cap}}(h) = \frac{1}{3}\pi h^2(45 - h). \text{ The volume of}$$

$$\text{the small sphere is } V_{\text{ball}} = \frac{4}{3}\pi(5)^3 = \frac{500}{3}\pi,$$

so the total volume is

$$V_{\text{cap}} - V_{\text{ball}} = \frac{1}{3}\pi(45h^2 - h^3 - 500) \text{ cm}^3.$$

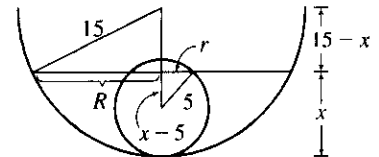
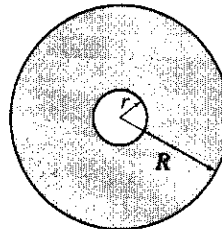

67. Take the x -axis to be the axis of the cylindrical hole of radius r .

A quarter of the cross-section through y , perpendicular to the y -axis, is the rectangle shown. Using the Pythagorean Theorem twice, we see that the dimensions of this rectangle are

$$x = \sqrt{R^2 - y^2} \text{ and } z = \sqrt{r^2 - y^2}, \text{ so}$$

$$\frac{1}{4}A(y) = xz = \sqrt{r^2 - y^2} \sqrt{R^2 - y^2}, \text{ and}$$

$$V = \int_{-r}^r A(y) dy = \int_{-r}^r 4 \sqrt{r^2 - y^2} \sqrt{R^2 - y^2} dy$$

$$= 8 \int_0^r \sqrt{r^2 - y^2} \sqrt{R^2 - y^2} dy$$

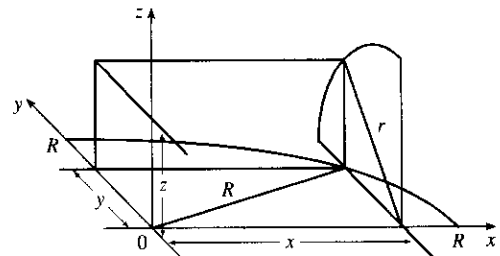

68. The line $y = r$ intersects the semicircle $y = \sqrt{R^2 - x^2}$ when $r = \sqrt{R^2 - x^2} \Rightarrow r^2 = R^2 - x^2 \Rightarrow x^2 = R^2 - r^2 \Rightarrow x = \pm\sqrt{R^2 - r^2}$. Rotating the shaded region about the x -axis gives us

$$\begin{aligned} V &= \int_{-\sqrt{R^2-r^2}}^{\sqrt{R^2-r^2}} \pi \left[\left(\sqrt{R^2-x^2} \right)^2 - r^2 \right] dx \\ &= 2\pi \int_0^{\sqrt{R^2-r^2}} (R^2 - x^2 - r^2) dx \quad [\text{by symmetry}] \\ &= 2\pi \int_0^{\sqrt{R^2-r^2}} [(R^2 - r^2) - x^2] dx = 2\pi \left[(R^2 - r^2)x - \frac{1}{3}x^3 \right]_0^{\sqrt{R^2-r^2}} \\ &= 2\pi \left[(R^2 - r^2)^{3/2} - \frac{1}{3}(R^2 - r^2)^{3/2} \right] \\ &= 2\pi \cdot \frac{2}{3}(R^2 - r^2)^{3/2} = \frac{4\pi}{3}(R^2 - r^2)^{3/2} \end{aligned}$$

Our answer makes sense in limiting cases. As $r \rightarrow 0$,

$V \rightarrow \frac{4}{3}\pi R^3$, which is the

volume of the full sphere. As

$r \rightarrow R$, $V \rightarrow 0$, which makes

sense because the hole's radius is approaching that of the sphere.

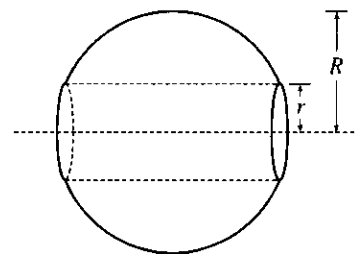
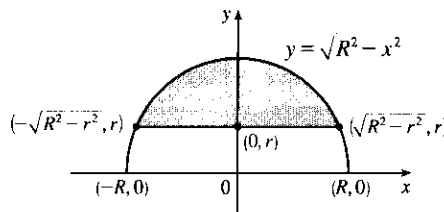

69. (a) The radius of the barrel is the same at each end by symmetry, since the function $y = R - cx^2$ is even. Since the barrel is obtained by rotating the graph of the function y about the x -axis, this radius is equal to the value of y at $x = \frac{1}{2}h$, which is $R - c(\frac{1}{2}h)^2 = R - d = r$.

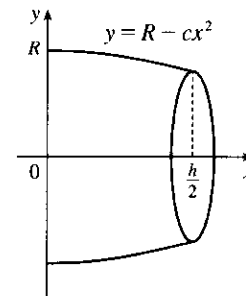

- (b) The barrel is symmetric about the y -axis, so its volume is twice the volume of that part of the barrel for $x > 0$.

Also, the barrel is a volume of rotation, so

$$\begin{aligned} V &= 2 \int_0^{h/2} \pi y^2 dx = 2\pi \int_0^{h/2} (R - cx^2)^2 dx = 2\pi \left[R^2x - \frac{2}{3}Rcx^3 + \frac{1}{5}c^2x^5 \right]_0^{h/2} \\ &= 2\pi \left(\frac{1}{2}R^2h - \frac{1}{12}Rch^3 + \frac{1}{160}c^2h^5 \right) \end{aligned}$$

Trying to make this look more like the expression we want, we rewrite it as

$$V = \frac{1}{3}\pi h \left[2R^2 + \left(R^2 - \frac{1}{2}Rch^2 + \frac{3}{80}c^2h^4 \right) \right]. \text{ But}$$

$$R^2 - \frac{1}{2}Rch^2 + \frac{3}{80}c^2h^4 = \left(R - \frac{1}{4}ch^2 \right)^2 - \frac{1}{40}c^2h^4 = (R - d)^2 - \frac{2}{5} \left(\frac{1}{4}ch^2 \right)^2 = r^2 - \frac{2}{5}d^2.$$

Substituting this back into V , we see that $V = \frac{1}{3}\pi h \left(2R^2 + r^2 - \frac{2}{5}d^2 \right)$, as required.

70. It suffices to consider the case where \mathcal{R} is bounded by the curves $y = f(x)$ and $y = g(x)$ for $a \leq x \leq b$, where $g(x) \leq f(x)$ for all x in $[a, b]$, since other regions can be decomposed into subregions of this type. We are concerned with the volume obtained when \mathcal{R} is rotated about the line $y = -k$, which is equal to

$$\begin{aligned} V_2 &= \pi \int_a^b ([f(x) + k]^2 - [g(x) + k]^2) dx = \pi \int_a^b ([f(x)]^2 - [g(x)]^2) dx + 2\pi k \int_a^b [f(x) - g(x)] dx \\ &= V_1 + 2\pi k A \end{aligned}$$

6.3 Volumes by Cylindrical Shells

1.

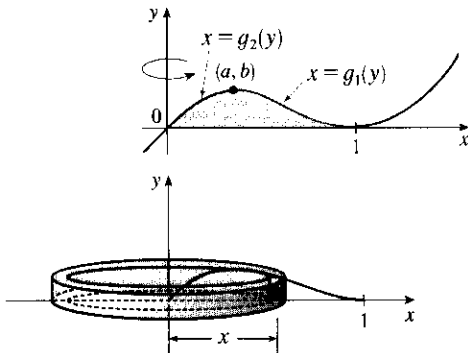

If we were to use the “washer” method, we would first have to locate the local maximum point (a, b) of $y = x(x - 1)^2$ using the methods of Chapter 4. Then we would have to solve the equation $y = x(x - 1)^2$ for x in terms of y to obtain the functions $x = g_1(y)$ and $x = g_2(y)$ shown in the first figure. This step would be difficult because it involves the cubic formula. Finally we would find the volume using

$$V = \pi \int_0^b \{ [g_1(y)]^2 - [g_2(y)]^2 \} dy.$$

Using shells, we find that a typical approximating shell has radius x , so its circumference is $2\pi x$. Its height is y , that is, $x(x - 1)^2$. So the total volume is

$$V = \int_0^1 2\pi x [x(x - 1)^2] dx = 2\pi \int_0^1 (x^4 - 2x^3 + x^2) dx = 2\pi \left[\frac{x^5}{5} - 2\frac{x^4}{4} + \frac{x^3}{3} \right]_0^1 = \frac{\pi}{15}$$

2.

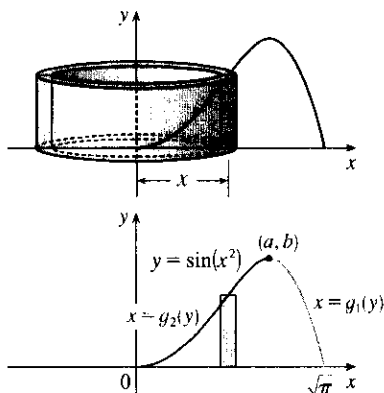

A typical cylindrical shell has circumference $2\pi x$ and height $\sin(x^2)$. $V = \int_0^{\sqrt{\pi}} 2\pi x \sin(x^2) dx$. Let $u = x^2$. Then $du = 2x dx$, so $V = \pi \int_0^{\pi} \sin u du = \pi [-\cos u]_0^{\pi} = \pi[1 - (-1)] = 2\pi$.

For slicing, we would first have to locate the local maximum point (a, b) of $y = \sin(x^2)$ using the methods of Chapter 4. Then we would have to solve the equation $y = \sin(x^2)$ for x in terms of y to obtain the functions $x = g_1(y)$ and $x = g_2(y)$ shown in the second figure. Finally we would find the volume using

$V = \pi \int_0^b \{ [g_1(y)]^2 - [g_2(y)]^2 \} dy$. Using shells is definitely preferable to slicing.

$$\begin{aligned} 3. V &= \int_1^2 2\pi x \cdot \frac{1}{x} dx = 2\pi \int_1^2 1 dx \\ &= 2\pi [x]_1^2 = 2\pi(2 - 1) = 2\pi \end{aligned}$$

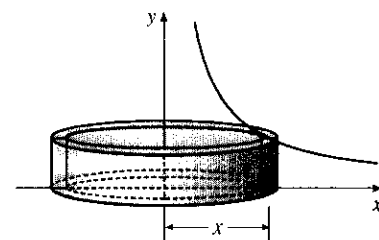
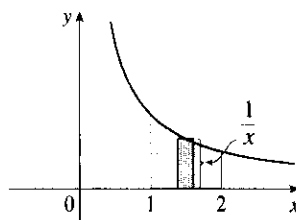

$$4. V = \int_0^1 2\pi x \cdot x^2 dx = 2\pi \int_0^1 x^3 dx$$

$$= 2\pi \left[\frac{1}{4} x^4 \right]_0^1 = 2\pi \cdot \frac{1}{4} = \frac{\pi}{2}$$

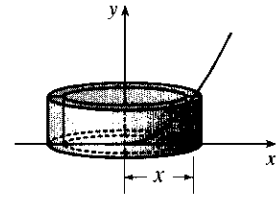
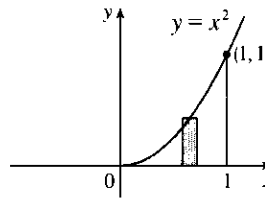

$$5. V = \int_0^2 2\pi x (4 - x^2) dx = 2\pi \int_0^2 (4x - x^3) dx$$

$$= 2\pi \left[2x^2 - \frac{1}{4} x^4 \right]_0^2 = 2\pi (8 - 4)$$

$$= 8\pi$$

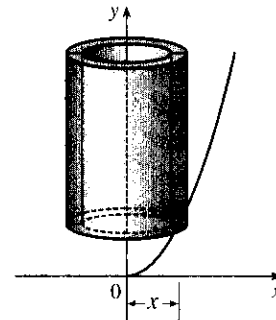
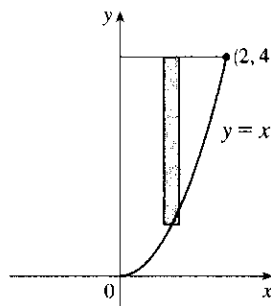

$$6. V = 2\pi \int_0^3 \{x[(3 + 2x - x^2) - (3 - x)]\} dx = 2\pi \int_0^3 [x(3x - x^2)] dx$$

$$= 2\pi \int_0^3 (3x^2 - x^3) dx = 2\pi \left[x^3 - \frac{1}{4} x^4 \right]_0^3 = 2\pi \left(27 - \frac{81}{4} \right) = 2\pi \left(\frac{27}{4} \right) = \frac{27\pi}{2}$$

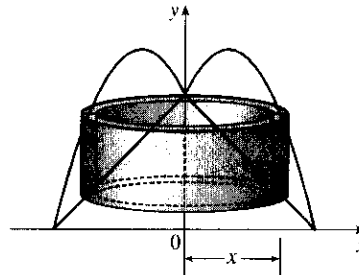
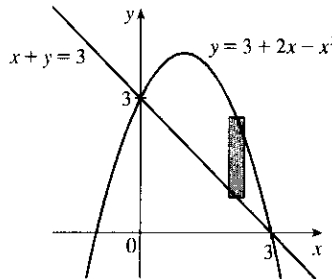

7. The curves intersect when $4(x - 2)^2 = x^2 - 4x + 7 \Leftrightarrow 4x^2 - 16x + 16 = x^2 - 4x + 7 \Leftrightarrow 3x^2 - 12x + 9 = 0 \Leftrightarrow 3(x^2 - 4x + 3) = 0 \Leftrightarrow 3(x - 1)(x - 3) = 0$, so $x = 1$ or 3 .

$$V = 2\pi \int_1^3 \{x[(x^2 - 4x + 7) - 4(x - 2)^2]\} dx = 2\pi \int_1^3 [x(x^2 - 4x + 7 - 4x^2 + 16x - 16)] dx$$

$$= 2\pi \int_1^3 [x(-3x^2 + 12x - 9)] dx = 2\pi(-3) \int_1^3 (x^3 - 4x^2 + 3x) dx = -6\pi \left[\frac{1}{4} x^4 - \frac{4}{3} x^3 + \frac{3}{2} x^2 \right]_1^3$$

$$= -6\pi \left[\left(\frac{81}{4} - 36 + \frac{27}{2} \right) - \left(\frac{1}{4} - \frac{4}{3} + \frac{3}{2} \right) \right] = -6\pi \left(20 - 36 + 12 + \frac{4}{3} \right) = -6\pi \left(-\frac{8}{3} \right) = 16\pi$$

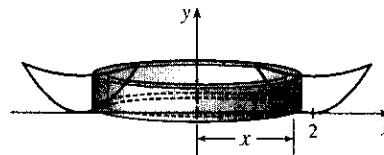
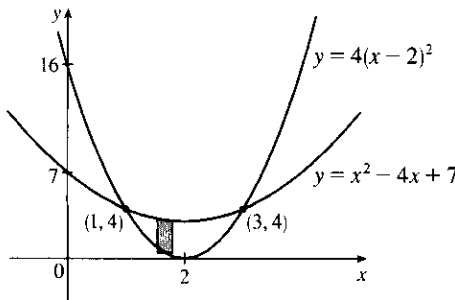

8. By slicing:

$$V = \int_0^1 \pi [(\sqrt{y})^2 - (y^2)^2] dy = \pi \int_0^1 (y - y^4) dy = \pi \left[\frac{1}{2}y^2 - \frac{1}{5}y^5 \right]_0^1 = \pi \left(\frac{1}{2} - \frac{1}{5} \right) = \frac{3\pi}{10}$$

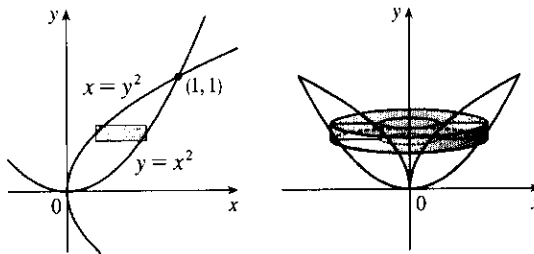

By cylindrical shells:

$$\begin{aligned} V &= \int_0^1 2\pi x(\sqrt{x} - x^2) dx = 2\pi \int_0^1 (x^{3/2} - x^3) dx \\ &= 2\pi \left[\frac{2}{5}x^{5/2} - \frac{1}{4}x^4 \right]_0^1 = 2\pi \left(\frac{2}{5} - \frac{1}{4} \right) \\ &= 2\pi \left(\frac{3}{20} \right) = \frac{3\pi}{10} \end{aligned}$$

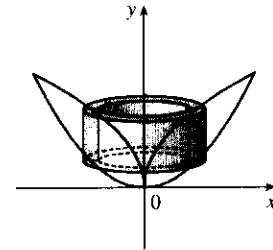

$$\begin{aligned} 9. V &= \int_1^2 2\pi y(1 + y^2) dy = 2\pi \int_1^2 (y + y^3) dy = 2\pi \left[\frac{1}{2}y^2 + \frac{1}{4}y^4 \right]_1^2 \\ &= 2\pi \left[(2 + 4) - \left(\frac{1}{2} + \frac{1}{4} \right) \right] = 2\pi \left(\frac{21}{4} \right) = \frac{21\pi}{2} \end{aligned}$$

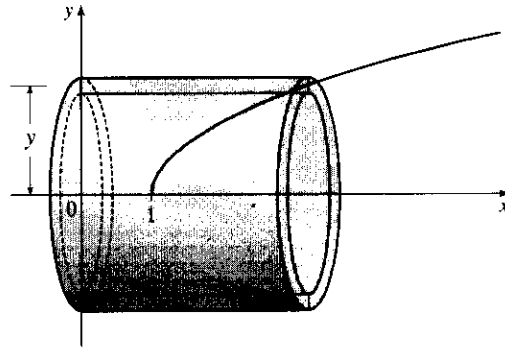
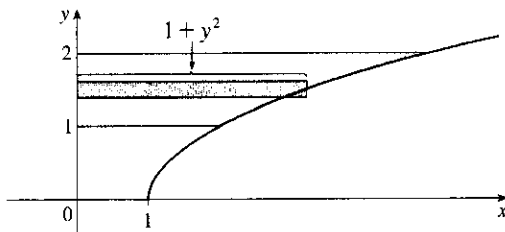

$$\begin{aligned} 10. V &= \int_0^1 2\pi y \sqrt{y} dy = 2\pi \int_0^1 y^{3/2} dy \\ &= 2\pi \left[\frac{2}{5}y^{5/2} \right]_0^1 = \frac{4\pi}{5} \end{aligned}$$

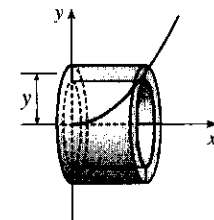
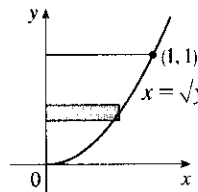

$$\begin{aligned}
 11. V &= 2\pi \int_0^8 [y(\sqrt[3]{y} - 0)] dy \\
 &= 2\pi \int_0^8 y^{4/3} dy = 2\pi \left[\frac{3}{7} y^{7/3} \right]_0^8 \\
 &= \frac{6\pi}{7} (8^{7/3}) = \frac{6\pi}{7} (2^7) = \frac{768\pi}{7}
 \end{aligned}$$

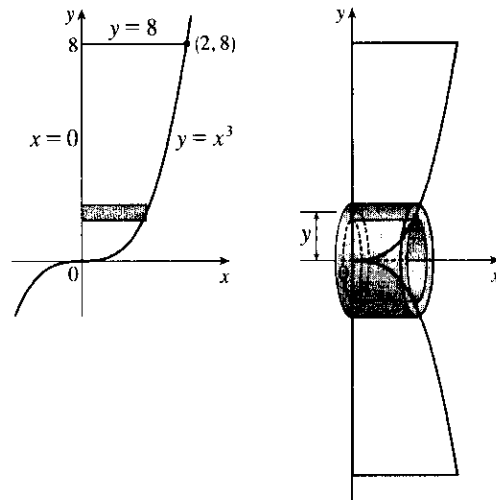

$$\begin{aligned}
 12. V &= 2\pi \int_0^4 [y(4y^2 - y^3)] dy \\
 &= 2\pi \int_0^4 (4y^3 - y^4) dy \\
 &= 2\pi \left[y^4 - \frac{1}{5} y^5 \right]_0^4 = 2\pi \left(256 - \frac{1024}{5} \right) \\
 &= 2\pi \left(\frac{256}{5} \right) = \frac{512\pi}{5}
 \end{aligned}$$

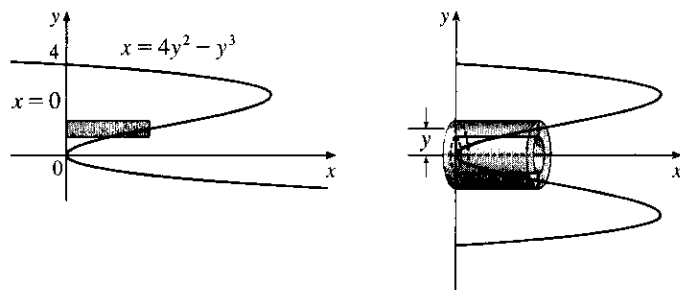

13. The curves intersect when $4x^2 = 6 - 2x \Leftrightarrow 2x^2 + x - 3 = 0 \Leftrightarrow (2x+3)(x-1) = 0 \Leftrightarrow x = -\frac{3}{2}$ or 1.

Solving the equations for x gives us $y = 4x^2 \Rightarrow x = \pm \frac{1}{2}\sqrt{y}$ and $2x + y = 6 \Rightarrow x = -\frac{1}{2}y + 3$.

$$\begin{aligned}
 V &= 2\pi \int_0^4 \left\{ y \left[\left(\frac{1}{2}\sqrt{y} \right) - \left(-\frac{1}{2}\sqrt{y} \right) \right] \right\} dy + 2\pi \int_4^9 \left\{ y \left[\left(-\frac{1}{2}y + 3 \right) - \left(-\frac{1}{2}\sqrt{y} \right) \right] \right\} dy \\
 &= 2\pi \int_0^4 (y\sqrt{y}) dy + 2\pi \int_4^9 \left(-\frac{1}{2}y^2 + 3y + \frac{1}{2}y^{3/2} \right) dy = 2\pi \left[\frac{2}{5}y^{5/2} \right]_0^4 + 2\pi \left[-\frac{1}{6}y^3 + \frac{3}{2}y^2 + \frac{1}{5}y^{5/2} \right]_4^9 \\
 &= 2\pi \left(\frac{2}{5} \cdot 32 \right) + 2\pi \left[\left(-\frac{243}{2} + \frac{243}{2} + \frac{243}{5} \right) - \left(-\frac{32}{3} + 24 + \frac{32}{5} \right) \right] \\
 &= \frac{128}{5}\pi + 2\pi \left(\frac{433}{15} \right) = \frac{1250}{15}\pi = \frac{250}{3}\pi
 \end{aligned}$$

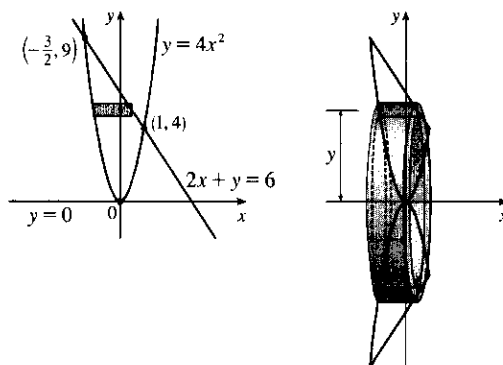

$$\begin{aligned}
 14. \quad V &= \int_0^3 2\pi y [4 - (y-1)^2 - (3-y)] dy \\
 &= 2\pi \int_0^3 y(-y^2 + 3y) dy \\
 &= 2\pi \int_0^3 (-y^3 + 3y^2) dy = 2\pi \left[-\frac{1}{4}y^4 + y^3 \right]_0^3 \\
 &= 2\pi \left(-\frac{81}{4} + 27 \right) = 2\pi \left(\frac{27}{4} \right) = \frac{27\pi}{2}
 \end{aligned}$$

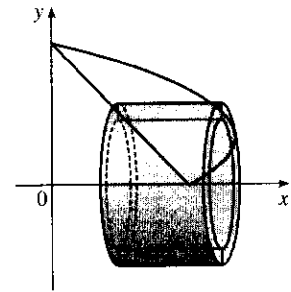
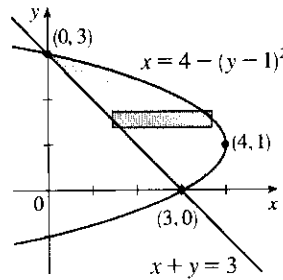

$$\begin{aligned}
 15. \quad V &= \int_1^2 2\pi(x-1)x^2 dx = 2\pi \left[\frac{1}{4}x^4 - \frac{1}{3}x^3 \right]_1^2 \\
 &= 2\pi \left[\left(4 - \frac{8}{3} \right) - \left(\frac{1}{4} - \frac{1}{3} \right) \right] = \frac{17\pi}{6}
 \end{aligned}$$

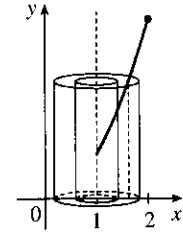
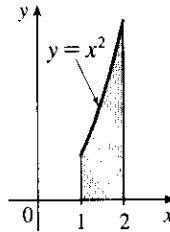

$$\begin{aligned}
 16. \quad V &= \int_{-2}^{-1} 2\pi(-x) \cdot x^2 dx = 2\pi \left[-\frac{1}{4}x^4 \right]_{-2}^{-1} \\
 &= 2\pi \left[\left(-\frac{1}{4} \right) - (-4) \right] = \frac{15\pi}{2}
 \end{aligned}$$

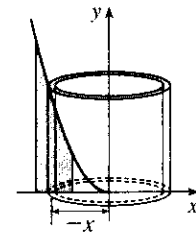
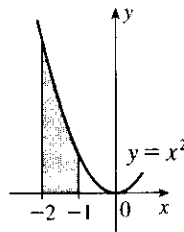

$$\begin{aligned}
 17. \quad V &= \int_1^2 2\pi(4-x)x^2 dx = 2\pi \left[\frac{4}{3}x^3 - \frac{1}{4}x^4 \right]_1^2 \\
 &= 2\pi \left[\left(\frac{32}{3} - 4 \right) - \left(\frac{4}{3} - \frac{1}{4} \right) \right] = \frac{67\pi}{6}
 \end{aligned}$$

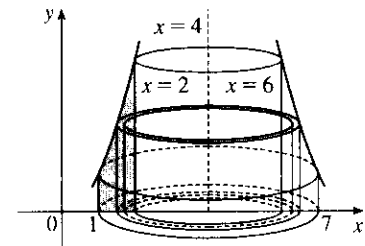
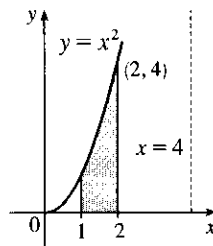

$$\begin{aligned}
 18. \quad V &= \int_0^4 2\pi[x - (-2)][(8x - 2x^2) - (4x - x^2)] dx \\
 &= \int_0^4 2\pi(2+x)(4x - x^2) dx \\
 &= 2\pi \int_0^4 (8x + 2x^2 - x^3) dx \\
 &= 2\pi \left[4x^2 + \frac{2}{3}x^3 - \frac{1}{4}x^4 \right]_0^4 \\
 &= 2\pi \left(64 + \frac{128}{3} - 64 \right) = \frac{256\pi}{3}
 \end{aligned}$$

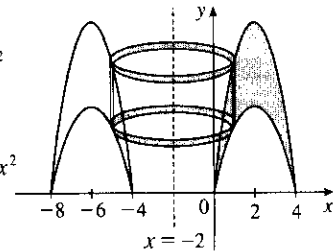
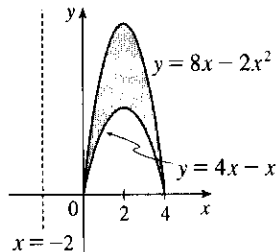

$$\begin{aligned}
 19. V &= \int_0^2 2\pi(3-y)(5-x)dy \\
 &= \int_0^2 2\pi(3-y)(5-y^2-1)dy \\
 &= \int_0^2 2\pi(12-4y-3y^2+y^3)dy \\
 &= 2\pi\left[12y-2y^2-y^3+\frac{1}{4}y^4\right]_0^2 \\
 &= 2\pi(24-8-8+4) = 24\pi
 \end{aligned}$$

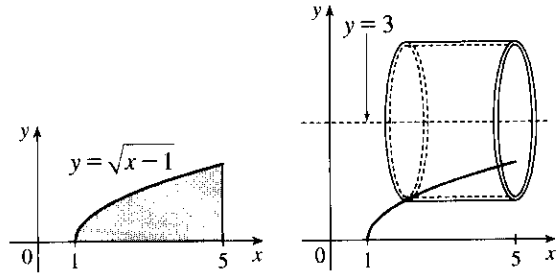

$$\begin{aligned}
 20. V &= \int_0^1 2\pi(y+1)(\sqrt{y}-y^2)dy = 2\pi \int_0^1 (y^{3/2} + y^{1/2} - y^3 - y^2)dy \\
 &= 2\pi\left[\frac{2}{5}y^{5/2} + \frac{2}{3}y^{3/2} - \frac{1}{4}y^4 - \frac{1}{3}y^3\right]_0^1 = 2\pi\left(\frac{2}{5} + \frac{2}{3} - \frac{1}{4} - \frac{1}{3}\right) = 2\pi\left(\frac{29}{60}\right) = \frac{29\pi}{30}
 \end{aligned}$$

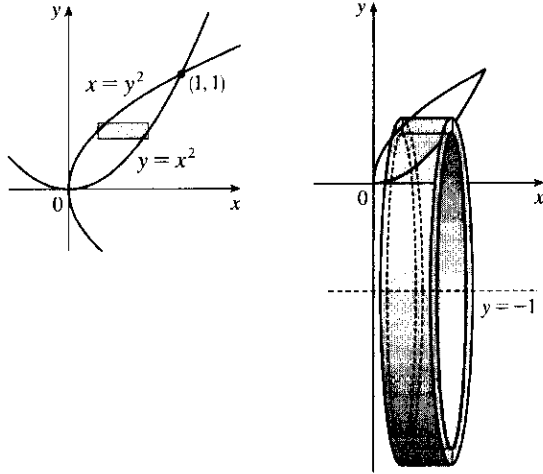

$$21. V = \int_{2\pi}^{3\pi} 2\pi x \sin x dx$$

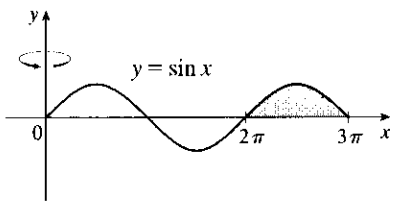

$$22. V = \int_0^3 2\pi(7-x)[(4x-x^2)-x]dx$$

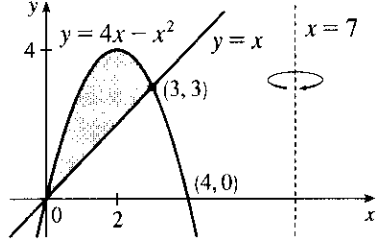

$$23. V = \int_0^1 2\pi[x - (-1)](\sin \frac{\pi}{2}x - x^4)dx$$

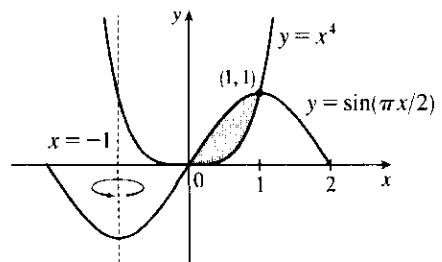

$$24. V = \int_0^2 2\pi(2-x)\left(\frac{1}{1+x^2}\right)dx$$

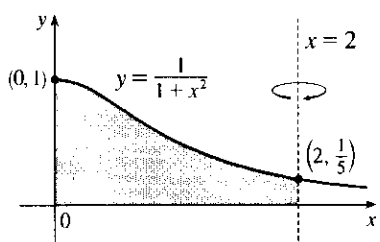

25. $V = \int_0^\pi 2\pi(4 - y) \sqrt{\sin y} dy$

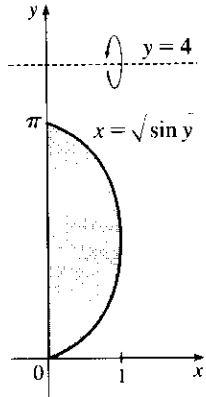

26. $V = \int_{-3}^3 2\pi(5 - y) (4 - \sqrt{y^2 + 7}) dy$

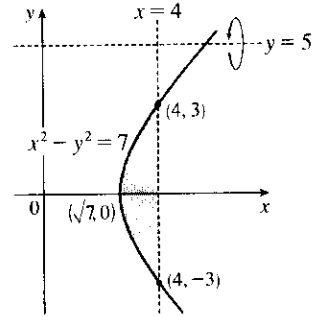

27. $\Delta x = \frac{\pi/4 - 0}{4} = \frac{\pi}{16}$

$V = \int_0^{\pi/4} 2\pi x \tan x dx \approx 2\pi \cdot \frac{\pi}{16} \left(\frac{\pi}{32} \tan \frac{\pi}{32} + \frac{3\pi}{32} \tan \frac{3\pi}{32} + \frac{5\pi}{32} \tan \frac{5\pi}{32} + \frac{7\pi}{32} \tan \frac{7\pi}{32} \right) \approx 1.142$

28. $\Delta x = \frac{12-2}{5} = 2, n = 5$ and $x_i^* = 2 + (2i + 1)$, where $i = 0, 1, 2, 3, 4$. The values of $f(x)$ are taken directly from the diagram.

$V = \int_2^{12} 2\pi x f(x) dx \approx 2\pi[3f(3) + 5f(5) + 7f(7) + 9f(9) + 11f(11)] \cdot 2$
 $\approx 2\pi[3(2) + 5(4) + 7(4) + 9(2) + 11(1)]2 = 332\pi$

29. $\int_0^3 2\pi x^5 dx = 2\pi \int_0^3 x(x^4) dx$. The solid is obtained by rotating the region $0 \leq y \leq x^4, 0 \leq x \leq 3$ about the y -axis using cylindrical shells.

30. $2\pi \int_0^2 \frac{y}{1+y^2} dy = 2\pi \int_0^2 y \left(\frac{1}{1+y^2} \right) dy$. The solid is obtained by rotating the region $0 \leq x \leq \frac{1}{1+y^2}, 0 \leq y \leq 2$ about the x -axis using cylindrical shells.

31. $\int_0^1 2\pi(3 - y)(1 - y^2) dy$. The solid is obtained by rotating the region bounded by (i) $x = 1 - y^2, x = 0$, and $y = 0$ or (ii) $x = y^2, x = 1$, and $y = 0$ about the line $y = 3$ using cylindrical shells.

32. $\int_0^{\pi/4} 2\pi(\pi - x)(\cos x - \sin x) dx$. The solid is obtained by rotating the region bounded by (i) $0 \leq y \leq \cos x - \sin x, 0 \leq x \leq \frac{\pi}{4}$ or (ii) $\sin x \leq y \leq \cos x, 0 \leq x \leq \frac{\pi}{4}$ about the line $x = \pi$ using cylindrical shells.

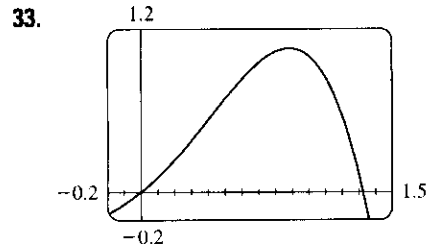

From the graph, the curves intersect at $x = 0$ and at $x = a \approx 1.32$, with $x + x^2 - x^4 > 0$ on the interval $(0, a)$. So the volume of the solid obtained by rotating the region about the y -axis is

$V = 2\pi \int_0^a [x(x + x^2 - x^4)] dx = 2\pi \int_0^a (x^2 + x^3 - x^5) dx$
 $= 2\pi \left[\frac{1}{3}x^3 + \frac{1}{4}x^4 - \frac{1}{6}x^6 \right]_0^a \approx 4.05$

34.

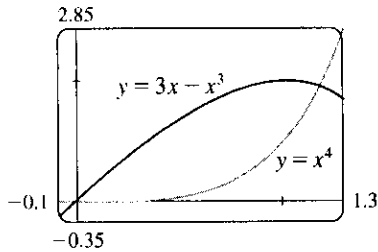

From the graph, the curves intersect at $x = 0$ and at $x = a \approx 1.17$, with $3x - x^3 > x^4$ on the interval $(0, a)$. So the volume of the solid obtained by rotating the region about the y -axis is

$$\begin{aligned} V &= 2\pi \int_0^a \{x[(3x - x^3) - x^4]\} dx = 2\pi \int_0^a (3x^2 - x^4 - x^5) dx \\ &= 2\pi \left[x^3 - \frac{1}{5}x^5 - \frac{1}{6}x^6 \right]_0^a \approx 4.62 \end{aligned}$$

$$35. V = 2\pi \int_0^{\pi/2} \left[\left(\frac{\pi}{2} - x \right) (\sin^2 x - \sin^4 x) \right] dx$$

$$\stackrel{\text{CAS}}{=} \frac{1}{32} \pi^3$$

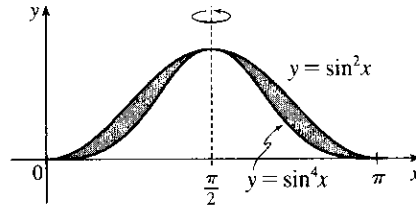

$$36. V = 2\pi \int_0^{\pi} \{ [x - (-1)] (x^3 \sin x) \} dx \stackrel{\text{CAS}}{=} 2\pi (\pi^4 + \pi^3 - 12\pi^2 - 6\pi + 48)$$

$$= 2\pi^5 + 2\pi^4 - 24\pi^3 - 12\pi^2 + 96\pi$$

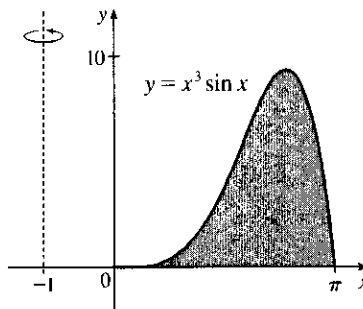

37. Use disks:

$$\begin{aligned} V &= \int_{-2}^1 \pi (x^2 + x - 2)^2 dx = \pi \int_{-2}^1 (x^4 + 2x^3 - 3x^2 - 4x + 4) dx \\ &= \pi \left[\frac{1}{5}x^5 + \frac{1}{2}x^4 - x^3 - 2x^2 + 4x \right]_{-2}^1 = \pi \left[\left(\frac{1}{5} + \frac{1}{2} - 1 - 2 + 4 \right) - \left(-\frac{32}{5} + 8 + 8 - 8 - 8 \right) \right] \\ &= \pi \left(\frac{33}{5} + \frac{3}{2} \right) = \frac{81}{10} \pi \end{aligned}$$

38. Use shells:

$$\begin{aligned} V &= \int_1^2 2\pi x (-x^2 + 3x - 2) dx = 2\pi \int_1^2 (-x^3 + 3x^2 - 2x) dx \\ &= 2\pi \left[-\frac{1}{4}x^4 + x^3 - x^2 \right]_1^2 = 2\pi \left[(-4 + 8 - 4) - \left(-\frac{1}{4} + 1 - 1 \right) \right] = \frac{\pi}{2} \end{aligned}$$

39. Use shells:

$$\begin{aligned}
 V &= \int_1^4 2\pi [x - (-1)] [5 - (x^2 - 5x + 9)] dx \\
 &= 2\pi \int_1^4 (x + 1) (-x^2 + 5x - 4) dx \\
 &= 2\pi \int_1^4 (-x^3 + 4x^2 + x - 4) dx = 2\pi \left[-\frac{1}{4}x^4 + \frac{4}{3}x^3 + \frac{1}{2}x^2 - 4x\right]_1^4 \\
 &= 2\pi \left[(-64 + \frac{256}{3} + 8 - 16) - (-\frac{1}{4} + \frac{4}{3} + \frac{1}{2} - 4)\right] \\
 &= 2\pi \left(\frac{63}{4}\right) = \frac{63\pi}{2}
 \end{aligned}$$

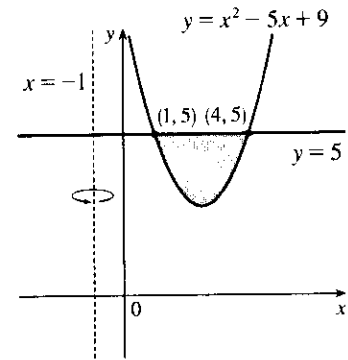

40. Use washers:

$$\begin{aligned}
 V &= \int_{-1}^1 \pi \left\{ [2 - 0]^2 - [2 - (1 - y^4)]^2 \right\} dy \\
 &= 2\pi \int_0^1 [4 - (1 + y^4)^2] dy \quad [\text{by symmetry}] \\
 &= 2\pi \int_0^1 [4 - (1 + 2y^4 + y^8)] dy = 2\pi \int_0^1 (3 - 2y^4 - y^8) dy \\
 &= 2\pi \left[3y - \frac{2}{5}y^5 - \frac{1}{9}y^9\right]_0^1 = 2\pi \left(3 - \frac{2}{5} - \frac{1}{9}\right) = 2\pi \left(\frac{112}{45}\right) = \frac{224\pi}{45}
 \end{aligned}$$

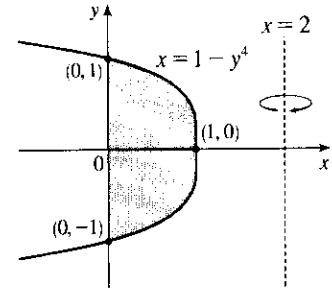

$$41. \text{ Use disks: } V = \pi \int_0^2 \left[\sqrt{1 - (y-1)^2} \right]^2 dy = \pi \int_0^2 (2y - y^2) dy = \pi \left[y^2 - \frac{1}{3}y^3 \right]_0^2 = \pi \left(4 - \frac{8}{3} \right) = \frac{4}{3}\pi$$

42. Using shells, we have

$$\begin{aligned}
 V &= \int_0^2 2\pi y \left[\sqrt{1 - (y-1)^2} - \left(-\sqrt{1 - (y-1)^2} \right) \right] dy \\
 &= 2\pi \int_0^2 y \cdot 2\sqrt{1 - (y-1)^2} dy = 4\pi \int_{-1}^1 (u+1)\sqrt{1-u^2} du \quad [\text{let } u = y-1] \\
 &= 4\pi \int_{-1}^1 u\sqrt{1-u^2} du + 4\pi \int_{-1}^1 \sqrt{1-u^2} du
 \end{aligned}$$

The first definite integral equals zero because its integrand is an odd function. The second is the area of a semicircle of radius 1, that is, $\frac{\pi}{2}$. Thus, $V = 4\pi \cdot 0 + 4\pi \cdot \frac{\pi}{2} = 2\pi^2$.

$$\begin{aligned}
 43. \quad V &= 2 \int_0^r 2\pi x \sqrt{r^2 - x^2} dx = -2\pi \int_0^r (r^2 - x^2)^{1/2} (-2x) dx = \left[-2\pi \cdot \frac{2}{3} (r^2 - x^2)^{3/2} \right]_0^r \\
 &= -\frac{4}{3}\pi(0 - r^3) = \frac{4}{3}\pi r^3
 \end{aligned}$$

$$\begin{aligned}
 44. \quad V &= \int_{R-r}^{R+r} 2\pi x \cdot 2\sqrt{r^2 - (x-R)^2} dx \\
 &= \int_{-r}^r 4\pi(u+R)\sqrt{r^2 - u^2} du \quad [\text{let } u = x - R] \\
 &= 4\pi R \int_{-r}^r \sqrt{r^2 - u^2} du + 4\pi \int_{-r}^r u\sqrt{r^2 - u^2} du
 \end{aligned}$$

The first integral is the area of a semicircle of radius r , that is, $\frac{1}{2}\pi r^2$, and the second is zero since the integrand is an odd function. Thus,

$$V = 4\pi R \left(\frac{1}{2}\pi r^2\right) + 4\pi \cdot 0 = 2\pi R r^2.$$

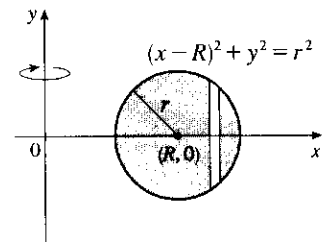

$$45. V = 2\pi \int_0^r x \left(-\frac{h}{r}x + h \right) dx = 2\pi h \int_0^r \left(-\frac{x^2}{r} + x \right) dx = 2\pi h \left[-\frac{x^3}{3r} + \frac{x^2}{2} \right]_0^r = 2\pi h \frac{r^2}{6} = \frac{\pi r^2 h}{3}$$

46. By symmetry, the volume of a napkin ring obtained by drilling a hole of radius r through a sphere with radius R is twice the volume obtained by rotating the area above the x -axis and below the curve $y = \sqrt{R^2 - x^2}$ (the equation of the top half of the cross-section of the sphere), between $x = r$ and $x = R$, about the y -axis.

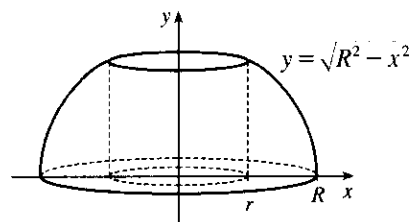

This volume is equal to

$$2 \int_{\text{inner radius}}^{\text{outer radius}} 2\pi r h dx = 2 \cdot 2\pi \int_r^R x \sqrt{R^2 - x^2} dx = 4\pi \left[-\frac{1}{3} (R^2 - x^2)^{3/2} \right]_r^R = \frac{4}{3}\pi (R^2 - r^2)^{3/2}$$

But by the Pythagorean Theorem, $R^2 - r^2 = (\frac{1}{2}h)^2$, so the volume of the napkin ring is $\frac{4}{3}\pi (\frac{1}{2}h)^3 = \frac{1}{6}\pi h^3$, which is independent of both R and r ; that is, the amount of wood in a napkin ring of height h is the same regardless of the size of the sphere used. Note that most of this calculation has been done already, but with more difficulty, in Exercise 6.2.68.

Another solution: The height of the missing cap is the radius of the sphere minus half the height of the cut-out cylinder, that is, $R - \frac{1}{2}h$. Using Exercise 6.2.49,

$$V_{\text{napkin ring}} = V_{\text{sphere}} - V_{\text{cylinder}} - 2V_{\text{cap}} = \frac{4}{3}\pi R^3 - \pi r^2 h - 2 \cdot \frac{\pi}{3} (R - \frac{1}{2}h)^2 [3R - (R - \frac{1}{2}h)] = \frac{1}{6}\pi h^3$$

6.4 Work

1. By Equation 2, $W = Fd = (900)(8) = 7200$ J.

2. $F = mg = (60)(9.8) = 588$ N; $W = Fd = 588 \cdot 2 = 1176$ J

$$3. W = \int_a^b f(x) dx = \int_0^9 \frac{10}{(1+x)^2} dx = 10 \int_1^{10} \frac{1}{u^2} du \quad [u = 1+x, du = dx]$$

$$= 10 \left[-\frac{1}{u} \right]_1^{10} = 10 \left(-\frac{1}{10} + 1 \right) = 9 \text{ ft}\cdot\text{lb}$$

4. $W = \int_1^2 \cos\left(\frac{1}{3}\pi x\right) dx = \frac{3}{\pi} \left[\sin\left(\frac{1}{3}\pi x\right) \right]_1^2 = \frac{3}{\pi} \left(\frac{\sqrt{3}}{2} - \frac{\sqrt{3}}{2} \right) = 0$ N·m = 0 J.

Interpretation: From $x = 1$ to $x = \frac{3}{2}$, the force does work equal to $\int_1^{3/2} \cos\left(\frac{1}{3}\pi x\right) dx = \frac{3}{\pi} \left(1 - \frac{\sqrt{3}}{2} \right)$ J in accelerating the particle and increasing its kinetic energy. From $x = \frac{3}{2}$ to $x = 2$, the force opposes the motion of the particle, decreasing its kinetic energy. This is negative work, equal in magnitude but opposite in sign to the work done from $x = 1$ to $x = \frac{3}{2}$.

5. The force function is given by $F(x)$ (in newtons) and the work (in joules) is the area under the curve, given by $\int_0^8 F(x) dx = \int_0^4 F(x) dx + \int_4^8 F(x) dx = \frac{1}{2}(4)(30) + (4)(30) = 180$ J.

6. $W = \int_4^{20} f(x) dx \approx M_4 = \Delta x [f(6) + f(10) + f(14) + f(18)] = \frac{20-4}{4} [5.8 + 8.8 + 8.2 + 5.2] = 4(28) = 112$ J

7. $10 = f(x) = kx = \frac{1}{3}k$ [4 inches = $\frac{1}{3}$ foot], so $k = 30$ lb/ft and $f(x) = 30x$. Now 6 inches = $\frac{1}{2}$ foot, so $W = \int_0^{1/2} 30x dx = [15x^2]_0^{1/2} = \frac{15}{4}$ ft·lb.

8. $25 = f(x) = kx = k(0.1)$ [10 cm = 0.1 m], so $k = 250$ N/m and $f(x) = 250x$. Now 5 cm = 0.05 m, so

$$W = \int_0^{0.05} 250x \, dx = [125x^2]_0^{0.05} = 125(0.0025) = 0.3125 \approx 0.31 \text{ J.}$$

9. If $\int_0^{0.12} kx \, dx = 2$ J, then $2 = [\frac{1}{2}kx^2]_0^{0.12} = \frac{1}{2}k(0.0144) = 0.0072k$ and $k = \frac{2}{0.0072} = \frac{2500}{9} \approx 277.78$ N/m.

Thus, the work needed to stretch the spring from 35 cm to 40 cm is

$$\int_{0.05}^{0.10} \frac{2500}{9} x \, dx = [\frac{1250}{9} x^2]_{1/20}^{1/10} = \frac{1250}{9} (\frac{1}{100} - \frac{1}{400}) = \frac{25}{24} \approx 1.04 \text{ J.}$$

10. If $12 = \int_0^1 kx \, dx = [\frac{1}{2}kx^2]_0^1 = \frac{1}{2}k$, then $k = 24$ lb/ft and the work required is

$$\int_0^{3/4} 24x \, dx = [12x^2]_0^{3/4} = 12 \cdot \frac{9}{16} = \frac{27}{4} = 6.75 \text{ ft}\cdot\text{lb.}$$

11. $f(x) = kx$, so $30 = \frac{2500}{9}x$ and $x = \frac{270}{2500}$ m = 10.8 cm

12. Let L be the natural length of the spring in meters. Then

$$6 = \int_{0.10-L}^{0.12-L} kx \, dx = [\frac{1}{2}kx^2]_{0.10-L}^{0.12-L} = \frac{1}{2}k[(0.12-L)^2 - (0.10-L)^2] \text{ and}$$

$$10 = \int_{0.12-L}^{0.14-L} kx \, dx = [\frac{1}{2}kx^2]_{0.12-L}^{0.14-L} = \frac{1}{2}k[(0.14-L)^2 - (0.12-L)^2]. \text{ Simplifying gives us}$$

$$12 = k(0.0044 - 0.04L) \text{ and } 20 = k(0.0052 - 0.04L). \text{ Subtracting the first equation from the second gives}$$

$$8 = 0.0008k, \text{ so } k = 10,000. \text{ Now the second equation becomes } 20 = 52 - 400L, \text{ so } L = \frac{32}{400} \text{ m} = 8 \text{ cm.}$$

In Exercises 13–20, n is the number of subintervals of length Δx , and x_i^* is a sample point in the i th subinterval $[x_{i-1}, x_i]$.

13. (a) The portion of the rope from x ft to $(x + \Delta x)$ ft below the top of the building weighs $\frac{1}{2} \Delta x$ lb and must be lifted x_i^* ft, so its contribution to the total work is $\frac{1}{2} x_i^* \Delta x$ ft·lb. The total work is

$$W = \lim_{n \rightarrow \infty} \sum_{i=1}^n \frac{1}{2} x_i^* \Delta x = \int_0^{50} \frac{1}{2} x \, dx = [\frac{1}{4} x^2]_0^{50} = \frac{2500}{4} = 625 \text{ ft}\cdot\text{lb}$$

Notice that the exact height of the building does not matter (as long as it is more than 50 ft).

(b) When half the rope is pulled to the top of the building, the work to lift the top half of the rope is

$$W_1 = \int_0^{25} \frac{1}{2} x \, dx = [\frac{1}{4} x^2]_0^{25} = \frac{625}{4} \text{ ft}\cdot\text{lb.} \text{ The bottom half of the rope is lifted 25 ft and the work needed to accomplish that is } W_2 = \int_{25}^{50} \frac{1}{2} \cdot 25 \, dx = \frac{25}{2} [x]_{25}^{50} = \frac{625}{2} \text{ ft}\cdot\text{lb.} \text{ The total work done in pulling half the rope to the top of the building is } W = W_1 + W_2 = \frac{625}{2} + \frac{625}{4} = \frac{3}{4} \cdot 625 = \frac{1875}{4} \text{ ft}\cdot\text{lb.}$$

14. *Assumptions:* 1. After lifting, the chain is L-shaped, with 4 m of the chain lying along the ground.

2. The chain slides effortlessly and without friction along the ground while its end is lifted.

3. The weight density of the chain is constant throughout its length and therefore equals

$$(8 \text{ kg/m})(9.8 \text{ m/s}^2) = 78.4 \text{ N/m.}$$

The part of the chain x m from the lifted end is raised $6 - x$ m if $0 \leq x \leq 6$ m, and it is lifted 0 m if $x > 6$ m.

Thus, the work needed is

$$W = \lim_{n \rightarrow \infty} \sum_{i=1}^n (6 - x_i^*) \cdot 78.4 \Delta x = \int_0^6 (6 - x) 78.4 \, dx = 78.4 [6x - \frac{1}{2} x^2]_0^6 = (78.4)(18) = 1411.2 \text{ J.}$$

15. The work needed to lift the cable is $\lim_{n \rightarrow \infty} \sum_{i=1}^n 2x_i^* \Delta x = \int_0^{500} 2x \, dx = [x^2]_0^{500} = 250,000$ ft·lb. The work needed to lift the coal is $800 \text{ lb} \cdot 500 \text{ ft} = 400,000$ ft·lb. Thus, the total work required is $250,000 + 400,000 = 650,000$ ft·lb.

16. The work needed to lift the bucket itself is $4 \text{ lb} \cdot 80 \text{ ft} = 320 \text{ ft}\cdot\text{lb}$. At time t (in seconds) the bucket is $x_i^* = 2t$ ft above its original 80 ft depth, but it now holds only $(40 - 0.2t)$ lb of water. In terms of distance, the bucket holds $[40 - 0.2(\frac{1}{2}x_i^*)]$ lb of water when it is x_i^* ft above its original 80 ft depth. Moving this amount of water a distance Δx requires $(40 - \frac{1}{10}x_i^*) \Delta x$ ft·lb of work. Thus, the work needed to lift the water is

$$W = \lim_{n \rightarrow \infty} \sum_{i=1}^n (40 - \frac{1}{10}x_i^*) \Delta x = \int_0^{80} (40 - \frac{1}{10}x) dx = [40x - \frac{1}{20}x^2]_0^{80} = (3200 - 320) \text{ ft}\cdot\text{lb}$$

Adding the work of lifting the bucket gives a total of 3200 ft·lb of work.

17. At a height of x meters ($0 \leq x \leq 12$), the mass of the rope is $(0.8 \text{ kg/m})(12 - x \text{ m}) = (9.6 - 0.8x)$ kg and the mass of the water is $(\frac{36}{12} \text{ kg/m})(12 - x \text{ m}) = (36 - 3x)$ kg. The mass of the bucket is 10 kg, so the total mass is $(9.6 - 0.8x) + (36 - 3x) + 10 = (55.6 - 3.8x)$ kg, and hence, the total force is $9.8(55.6 - 3.8x)$ N.

The work needed to lift the bucket Δx m through the i th subinterval of $[0, 12]$ is $9.8(55.6 - 3.8x_i^*)\Delta x$, so the total work is

$$\begin{aligned} W &= \lim_{n \rightarrow \infty} \sum_{i=1}^n 9.8(55.6 - 3.8x_i^*) \Delta x = \int_0^{12} (9.8)(55.6 - 3.8x) dx = 9.8 [55.6x - 1.9x^2]_0^{12} \\ &= 9.8(393.6) \approx 3857 \text{ J} \end{aligned}$$

18. The chain's weight density is $\frac{25 \text{ lb}}{10 \text{ ft}} = 2.5 \text{ lb/ft}$. The part of the chain x ft below the ceiling (for $5 \leq x \leq 10$) has to be lifted $2(x - 5)$ ft, so the work needed to lift the i th subinterval of the chain is $2(x_i^* - 5)(2.5 \Delta x)$. The total work needed is

$$\begin{aligned} W &= \lim_{n \rightarrow \infty} \sum_{i=1}^n 2(x_i^* - 5)(2.5) \Delta x = \int_5^{10} [2(x - 5)(2.5)] dx = 5 \int_5^{10} (x - 5) dx \\ &= 5 [\frac{1}{2}x^2 - 5x]_5^{10} = 5 [(50 - 50) - (\frac{25}{2} - 25)] = 5(\frac{25}{2}) = 62.5 \text{ ft}\cdot\text{lb} \end{aligned}$$

19. A "slice" of water Δx m thick and lying at a depth of x_i^* m (where $0 \leq x_i^* \leq \frac{1}{2}$) has volume $(2 \times 1 \times \Delta x) \text{ m}^3$, a mass of $2000 \Delta x$ kg, weighs about $(9.8)(2000 \Delta x) = 19,600 \Delta x$ N, and thus requires about $19,600x_i^* \Delta x$ J of work for its removal. So $W = \lim_{n \rightarrow \infty} \sum_{i=1}^n 19,600x_i^* \Delta x = \int_0^{1/2} 19,600x dx = [9800x^2]_0^{1/2} = 2450 \text{ J}$.

20. A horizontal cylindrical slice of water Δx ft thick has a volume of $\pi r^2 h = \pi \cdot 12^2 \cdot \Delta x \text{ ft}^3$ and weighs about $(62.5 \text{ lb/ft}^3)(144\pi \Delta x \text{ ft}^3) = 9000\pi \Delta x$ lb. If the slice lies x_i^* ft below the edge of the pool (where $1 \leq x_i^* \leq 5$), then the work needed to pump it out is about $9000\pi x_i^* \Delta x$. Thus,

$$W = \lim_{n \rightarrow \infty} \sum_{i=1}^n 9000\pi x_i^* \Delta x = \int_1^5 9000\pi x dx = [4500\pi x^2]_1^5 = 4500\pi(25 - 1) = 108,000\pi \text{ ft}\cdot\text{lb}$$

21. A rectangular "slice" of water Δx m thick and lying x ft above the bottom has width x ft and volume $8x \Delta x \text{ m}^3$. It weighs about $(9.8 \times 1000)(8x \Delta x)$ N, and must be lifted $(5 - x)$ m by the pump, so the work needed is about $(9.8 \times 10^3)(5 - x)(8x \Delta x)$ J. The total work required is

$$\begin{aligned} W &\approx \int_0^3 (9.8 \times 10^3)(5 - x)8x dx = (9.8 \times 10^3) \int_0^3 (40x - 8x^2) dx = (9.8 \times 10^3) [20x^2 - \frac{8}{3}x^3]_0^3 \\ &= (9.8 \times 10^3)(180 - 72) = (9.8 \times 10^3)(108) = 1058.4 \times 10^3 \approx 1.06 \times 10^6 \text{ J} \end{aligned}$$

22. For convenience, measure depth x from the middle of the tank, so that $-1.5 \leq x \leq 1.5$ m.

Lifting a slice of water of thickness Δx at depth x requires a work contribution of

$$\Delta W \approx (9.8 \times 10^3) \left(2\sqrt{(1.5)^2 - x^2} \right) (6 \Delta x)(2.5 + x), \text{ so}$$

$$\begin{aligned} W &\approx \int_{-1.5}^{1.5} (9.8 \times 10^3) 12 \sqrt{2.25 - x^2} (2.5 + x) dx \\ &= (9.8 \times 10^3) \left[60 \int_0^{3/2} \sqrt{\frac{9}{4} - x^2} dx + 12 \int_{-3/2}^{3/2} x \sqrt{\frac{9}{4} - x^2} dx \right] \end{aligned}$$

The second integral is 0 because its integrand is an odd function, and the first integral represents the area of a quarter-circle of radius $\frac{3}{2}$. Therefore,

$$W \approx (9.8 \times 10^3) 60 \int_0^{3/2} \sqrt{\frac{9}{4} - x^2} dx = (9.8 \times 10^3) (60) \left(\frac{1}{4} \pi \right) \left(\frac{3}{2} \right)^2 = 330,750\pi \approx 1.04 \times 10^6 \text{ J}$$

23. Measure depth x downward from the flat top of the tank, so that $0 \leq x \leq 2$ ft. Then

$$\Delta W = (62.5)(2\sqrt{4 - x^2})(8 \Delta x)(x + 1) \text{ ft-lb, so}$$

$$\begin{aligned} W &\approx (62.5)(16) \int_0^2 (x + 1) \sqrt{4 - x^2} dx = 1000 \left(\int_0^2 x \sqrt{4 - x^2} dx + \int_0^2 \sqrt{4 - x^2} dx \right) \\ &= 1000 \left[\int_0^4 u^{1/2} \left(\frac{1}{2} du \right) + \frac{1}{4} \pi (2^2) \right] \quad [\text{Put } u = 4 - x^2, \text{ so } du = -2x dx] \\ &= 1000 \left(\left[\frac{1}{2} \cdot \frac{2}{3} u^{3/2} \right]_0^4 + \pi \right) = 1000 \left(\frac{8}{3} + \pi \right) \approx 5.8 \times 10^3 \text{ ft-lb} \end{aligned}$$

Note: The second integral represents the area of a quarter-circle of radius 2.

24. Let x be depth in feet, so that $0 \leq x \leq 5$. Then $\Delta W = (62.5)\pi(\sqrt{5^2 - x^2})^2 \Delta x \cdot x$ ft-lb and

$$\begin{aligned} W &\approx 62.5\pi \int_0^5 x(25 - x^2) dx = 62.5\pi \left[\frac{25}{2} x^2 - \frac{1}{4} x^4 \right]_0^5 = 62.5\pi \left(\frac{625}{2} - \frac{625}{4} \right) = 62.5\pi \left(\frac{625}{4} \right) \\ &\approx 3.07 \times 10^4 \text{ ft-lb} \end{aligned}$$

25. If only 4.7×10^5 J of work is done, then only the water above a certain level (call it h) will be pumped out. So we use the same formula as in Exercise 21, except that the work is fixed, and we are trying to find the lower limit of

$$\text{integration: } 4.7 \times 10^5 \approx \int_h^3 (9.8 \times 10^3)(5 - x)8x dx = (9.8 \times 10^3) \left[20x^2 - \frac{8}{3}x^3 \right]_h^3 \Leftrightarrow$$

$$\frac{4.7}{9.8} \times 10^2 \approx 48 = \left(20 \cdot 3^2 - \frac{8}{3} \cdot 3^3 \right) - \left(20h^2 - \frac{8}{3}h^3 \right) \Leftrightarrow$$

$2h^3 - 15h^2 + 45 = 0$. To find the solution of this equation, we plot

$2h^3 - 15h^2 + 45$ between $h = 0$ and $h = 3$. We see that the equation

is satisfied for $h \approx 2.0$. So the depth of water remaining in the tank is

about 2.0 m.

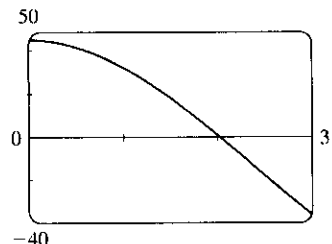

$$26. W \approx (9.8 \times 920) \int_0^{3/2} 12 \sqrt{\frac{9}{4} - x^2} \left(\frac{5}{2} + x\right) dx = 9016 \left[30 \int_0^{3/2} \sqrt{\frac{9}{4} - x^2} dx + 12 \int_0^{3/2} x \sqrt{\frac{9}{4} - x^2} dx \right].$$

$$\text{Here } \int_0^{3/2} \sqrt{\frac{9}{4} - x^2} dx = \frac{1}{4} \pi \left(\frac{3}{2}\right)^2 = \frac{9\pi}{16} \text{ and } \int_0^{3/2} x \sqrt{\frac{9}{4} - x^2} dx = \int_0^{9/4} \frac{1}{2} u^{1/2} du$$

$$[\text{where } u = \frac{9}{4} - x^2, \text{ so } du = -2x dx] = \left[\frac{1}{3} u^{3/2} \right]_0^{9/4} = \frac{1}{3} \left(\frac{27}{8}\right) = \frac{9}{8}, \text{ so}$$

$$W \approx 9016 \left[30 \cdot \frac{9\pi}{16} + 12 \cdot \frac{9}{8} \right] = 9016 \left(\frac{135}{8} \pi + \frac{27}{2} \right) \approx 6.00 \times 10^5 \text{ J.}$$

27. $V = \pi r^2 x$, so V is a function of x and P can also be regarded as a function of x . If $V_1 = \pi r^2 x_1$ and $V_2 = \pi r^2 x_2$, then

$$\begin{aligned} W &= \int_{x_1}^{x_2} F(x) dx = \int_{x_1}^{x_2} \pi r^2 P(V(x)) dx \\ &= \int_{x_1}^{x_2} P(V(x)) dV(x) \quad [\text{Let } V(x) = \pi r^2 x, \text{ so } dV(x) = \pi r^2 dx.] \\ &= \int_{V_1}^{V_2} P(V) dV \quad \text{by the Substitution Rule.} \end{aligned}$$

$$28. 160 \text{ lb/in}^2 = 160 \cdot 144 \text{ lb/ft}^2, 100 \text{ in}^3 = \frac{100}{1728} \text{ ft}^3, \text{ and } 800 \text{ in}^3 = \frac{800}{1728} \text{ ft}^3.$$

$$k = PV^{1.4} = (160 \cdot 144) \left(\frac{100}{1728}\right)^{1.4} = 23,040 \left(\frac{25}{432}\right)^{1.4} \approx 426.5. \text{ Therefore, } P \approx 426.5V^{-1.4} \text{ and}$$

$$\begin{aligned} W &= \int_{100/1728}^{800/1728} 426.5V^{-1.4} dV = 426.5 \left[\frac{-1}{-0.4} V^{-0.4} \right]_{25/432}^{25/54} \\ &= (426.5)(2.5) \left[\left(\frac{432}{25}\right)^{0.4} - \left(\frac{54}{25}\right)^{0.4} \right] \\ &\approx 1.88 \times 10^3 \text{ ft}\cdot\text{lb} \end{aligned}$$

$$29. W = \int_a^b F(r) dr = \int_a^b G \frac{m_1 m_2}{r^2} dr = G m_1 m_2 \left[\frac{-1}{r} \right]_a^b = G m_1 m_2 \left(\frac{1}{a} - \frac{1}{b} \right)$$

30. By Exercise 29, $W = GMm \left(\frac{1}{R} - \frac{1}{R + 1,000,000} \right)$ where M = mass of Earth in kg, R = radius of Earth in m, and m = mass of satellite in kg. (Note that 1000 km = 1,000,000 m.) Thus,

$$W = (6.67 \times 10^{-11})(5.98 \times 10^{24})(1000) \times \left(\frac{1}{6.37 \times 10^6} - \frac{1}{7.37 \times 10^6} \right) \approx 8.50 \times 10^9 \text{ J}$$

6.5 Average Value of a Function

$$1. f_{\text{ave}} = \frac{1}{b-a} \int_a^b f(x) dx = \frac{1}{1-(-1)} \int_{-1}^1 x^2 dx = \frac{1}{2} \cdot 2 \int_0^1 x^2 dx = \left[\frac{1}{3} x^3 \right]_0^1 = \frac{1}{3}$$

$$2. f_{\text{ave}} = \frac{1}{2-0} \int_0^2 (x-x^2) dx = \frac{1}{2} \left[\frac{1}{2} x^2 - \frac{1}{3} x^3 \right]_0^2 = \frac{1}{2} \left(2 - \frac{8}{3} \right) = -\frac{1}{3}$$

$$3. g_{\text{ave}} = \frac{1}{\frac{\pi}{2} - 0} \int_0^{\pi/2} \cos x \, dx = \frac{2}{\pi} [\sin x]_0^{\pi/2} = \frac{2}{\pi} (1 - 0) = \frac{2}{\pi}$$

$$4. g_{\text{ave}} = \frac{1}{2-0} \int_0^2 x^2 \sqrt{1+x^3} \, dx = \frac{1}{2} \int_1^9 \sqrt{u} \cdot \frac{1}{3} du \quad [u = 1+x^3, du = 3x^2 dx]$$

$$= \frac{1}{6} \left[\frac{2}{3} u^{3/2} \right]_1^9 = \frac{1}{9} (27 - 1) = \frac{26}{9}$$

$$5. f_{\text{ave}} = \frac{1}{5-0} \int_0^5 t \sqrt{1+t^2} \, dt = \frac{1}{5} \int_1^{26} \sqrt{u} \left(\frac{1}{2} du \right) \quad [u = 1+t^2, du = 2t dt]$$

$$= \frac{1}{10} \int_1^{26} u^{1/2} \, du = \frac{1}{10} \cdot \frac{2}{3} \left[u^{3/2} \right]_1^{26} = \frac{1}{15} (26^{3/2} - 1)$$

$$6. f_{\text{ave}} = \frac{1}{\frac{\pi}{4} - 0} \int_0^{\pi/4} \sec \theta \tan \theta \, d\theta = \frac{4}{\pi} [\sec \theta]_0^{\pi/4} = \frac{4}{\pi} (\sqrt{2} - 1)$$

$$7. h_{\text{ave}} = \frac{1}{\pi - 0} \int_0^{\pi} \cos^4 x \sin x \, dx = \frac{1}{\pi} \int_1^{-1} u^4 (-du) \quad [u = \cos x, du = -\sin x dx]$$

$$= \frac{1}{\pi} \int_{-1}^1 u^4 \, du = \frac{1}{\pi} \cdot 2 \int_0^1 u^4 \, du = \frac{2}{\pi} \left[\frac{1}{5} u^5 \right]_0^1 = \frac{2}{5\pi}$$

$$8. h_{\text{ave}} = \frac{1}{6-1} \int_1^6 \frac{3}{(1+r)^2} \, dr = \frac{1}{5} \int_2^7 3u^{-2} \, du \quad [u = 1+r, du = dr]$$

$$= -\frac{3}{5} [u^{-1}]_2^7 = -\frac{3}{5} \left(\frac{1}{7} - \frac{1}{2} \right) = \frac{3}{5} \left(\frac{1}{2} - \frac{1}{7} \right) = \frac{3}{5} \cdot \frac{5}{14} = \frac{3}{14}$$

$$9. (a) f_{\text{ave}} = \frac{1}{5-2} \int_2^5 (x-3)^2 \, dx = \frac{1}{3} \left[\frac{1}{3} (x-3)^3 \right]_2^5$$

$$= \frac{1}{9} [2^3 - (-1)^3] = \frac{1}{9} (8+1) = 1$$

$$(b) f(c) = f_{\text{ave}} \Leftrightarrow (c-3)^2 = 1 \Leftrightarrow c-3 = \pm 1$$

$$\Leftrightarrow c = 2 \text{ or } 4$$

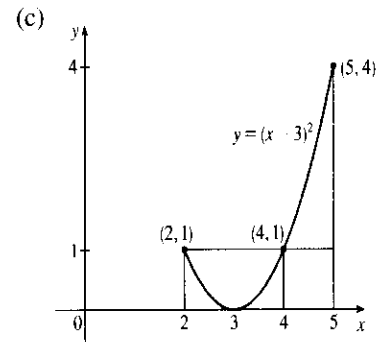

$$10. (a) f_{\text{ave}} = \frac{1}{4-0} \int_0^4 \sqrt{x} \, dx = \frac{1}{4} \left[\frac{2}{3} x^{3/2} \right]_0^4$$

$$= \frac{1}{6} [x^{3/2}]_0^4 = \frac{1}{6} [8 - 0] = \frac{4}{3}$$

$$(b) f(c) = f_{\text{ave}} \Leftrightarrow \sqrt{c} = \frac{4}{3} \Leftrightarrow c = \frac{16}{9}$$

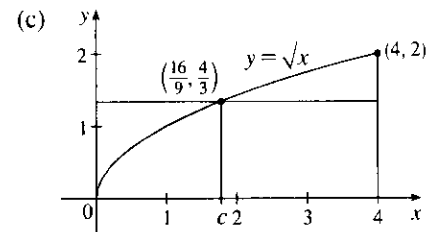

$$11. (a) f_{\text{ave}} = \frac{1}{\pi - 0} \int_0^{\pi} (2 \sin x - \sin 2x) \, dx$$

$$= \frac{1}{\pi} \left[-2 \cos x + \frac{1}{2} \cos 2x \right]_0^{\pi}$$

$$= \frac{1}{\pi} \left[\left(2 + \frac{1}{2} \right) - \left(-2 + \frac{1}{2} \right) \right] = \frac{4}{\pi}$$

$$(b) f(c) = f_{\text{ave}} \Leftrightarrow 2 \sin c - \sin 2c = \frac{4}{\pi} \Leftrightarrow$$

$$c_1 \approx 1.238 \text{ or } c_2 \approx 2.808$$

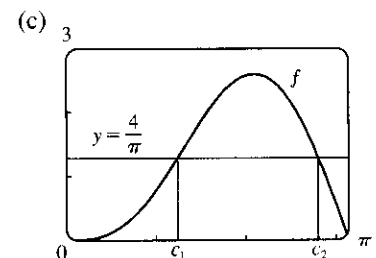

$$\begin{aligned}
 12. (a) f_{\text{ave}} &= \frac{1}{2-0} \int_0^2 \frac{2x}{(1+x^2)^2} dx \\
 &= \frac{1}{2} \int_1^5 \frac{1}{u^2} du \quad [u = 1+x^2, du = 2x dx] \\
 &= \frac{1}{2} \left[-\frac{1}{u} \right]_1^5 = -\frac{1}{2} \left(\frac{1}{5} - 1 \right) = \frac{2}{5}
 \end{aligned}$$

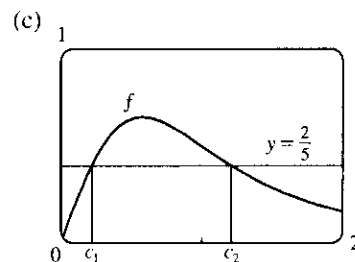

$$\begin{aligned}
 (b) f(c) = f_{\text{ave}} &\Leftrightarrow \frac{2c}{(1+c^2)^2} = \frac{2}{5} \Leftrightarrow 5c = (1+c^2)^2 \\
 &\Leftrightarrow c_1 \approx 0.220 \text{ or } c_2 \approx 1.207
 \end{aligned}$$

13. f is continuous on $[1, 3]$, so by the Mean Value Theorem for Integrals there exists a number c in $[1, 3]$ such that $\int_1^3 f(x) dx = f(c)(3-1) \Rightarrow 8 = 2f(c)$; that is, there is a number c such that $f(c) = \frac{8}{2} = 4$.

14. The requirement is that $\frac{1}{b-0} \int_0^b f(x) dx = 3$. The LHS of this equation is equal to

$$\begin{aligned}
 \frac{1}{b} \int_0^b (2+6x-3x^2) dx &= \frac{1}{b} [2x+3x^2-x^3]_0^b = 2+3b-b^2, \text{ so we solve the equation } 2+3b-b^2=3 \Leftrightarrow \\
 b^2-3b+1=0 &\Leftrightarrow b = \frac{3 \pm \sqrt{(-3)^2-4 \cdot 1 \cdot 1}}{2 \cdot 1} = \frac{3 \pm \sqrt{5}}{2}. \text{ Both roots are valid since they are positive.}
 \end{aligned}$$

$$\begin{aligned}
 15. f_{\text{ave}} &= \frac{1}{50-20} \int_{20}^{50} f(x) dx \approx \frac{1}{30} M_3 = \frac{1}{30} \cdot \frac{50-20}{3} [f(25) + f(35) + f(45)] \\
 &= \frac{1}{3} (38 + 29 + 48) = \frac{115}{3} = 38\frac{1}{3}
 \end{aligned}$$

16. (a) $v_{\text{ave}} = \frac{1}{12-0} \int_0^{12} v(t) dt = \frac{1}{12} I$. Use the Midpoint Rule with $n = 3$ and $\Delta t = \frac{12-0}{3} = 4$ to estimate I .

$$I \approx M_3 = 4[v(2) + v(6) + v(10)] = 4[21 + 50 + 66] = 4(137) = 548. \text{ Thus, } v_{\text{ave}} \approx \frac{1}{12}(548) = 45\frac{2}{3} \text{ km/h.}$$

(b) Estimating from the graph, $v(t) = 45\frac{2}{3}$ when $t \approx 5.2$ s.

17. Let $t = 0$ and $t = 12$ correspond to 9 A.M. and 9 P.M., respectively.

$$\begin{aligned}
 T_{\text{ave}} &= \frac{1}{12-0} \int_0^{12} \left[50 + 14 \sin \frac{1}{12} \pi t \right] dt = \frac{1}{12} \left[50t - 14 \cdot \frac{12}{\pi} \cos \frac{1}{12} \pi t \right]_0^{12} \\
 &= \frac{1}{12} \left[50 \cdot 12 + 14 \cdot \frac{12}{\pi} + 14 \cdot \frac{12}{\pi} \right] = \left(50 + \frac{28}{\pi} \right) ^\circ\text{F} \approx 59^\circ\text{F}
 \end{aligned}$$

$$18. T_{\text{ave}} = \frac{1}{5} \int_0^5 4x dx = \frac{1}{5} [2x^2]_0^5 = 10^\circ\text{C}$$

$$19. \rho_{\text{ave}} = \frac{1}{8} \int_0^8 \frac{12}{\sqrt{x+1}} dx = \frac{3}{2} \int_0^8 (x+1)^{-1/2} dx = [3\sqrt{x+1}]_0^8 = 9 - 3 = 6 \text{ kg/m}$$

$$20. s = \frac{1}{2}gt^2 \Rightarrow t = \sqrt{2s/g} \quad [\text{since } t \geq 0]. \text{ Now } v = \frac{ds}{dt} = gt = g\sqrt{2s/g} = \sqrt{2gs} \Rightarrow v^2 = 2gs \Rightarrow$$

$s = \frac{v^2}{2g}$. We see that v can be regarded as a function of t or of s : $v = F(t) = gt$ and $v = G(s) = \sqrt{2gs}$. Note that

$$v_T = F(T) = gT. \text{ Displacement can be viewed as a function of } t: s = s(t) = \frac{1}{2}gt^2; \text{ also } s(t) = \frac{v^2}{2g} = \frac{[F(t)]^2}{2g}.$$

When $t = T$, these two formulas for $s(t)$ imply that

$$\sqrt{2gs(T)} = F(T) = v_T = gT = 2(\frac{1}{2}gT^2)/T = 2s(T)/T \quad (*)$$

The average of the velocities with respect to time t during the interval $[0, T]$ is

$$\begin{aligned} v_{t\text{-ave}} = F_{\text{ave}} &= \frac{1}{T-0} \int_0^T F(t) dt = \frac{1}{T} [s(T) - s(0)] \quad [\text{by FTC}] \\ &= \frac{s(T)}{T} \quad [\text{since } s(0) = 0] = \frac{1}{2} v_T \quad [\text{by } (*)] \end{aligned}$$

But the average of the velocities with respect to displacement s during the corresponding displacement interval $[s(0), s(T)] = [0, s(T)]$ is

$$\begin{aligned} v_{s\text{-ave}} = G_{\text{ave}} &= \frac{1}{s(T) - 0} \int_0^{s(T)} G(s) ds = \frac{1}{s(T)} \int_0^{s(T)} \sqrt{2gs} ds = \frac{\sqrt{2g}}{s(T)} \int_0^{s(T)} s^{1/2} ds \\ &= \frac{\sqrt{2g}}{s(T)} \cdot \frac{2}{3} [s^{3/2}]_0^{s(T)} = \frac{2}{3} \cdot \frac{\sqrt{2g}}{s(T)} \cdot [s(T)]^{3/2} = \frac{2}{3} \sqrt{2gs(T)} = \frac{2}{3} v_T \quad [\text{by } (*)] \end{aligned}$$

$$\begin{aligned} 21. V_{\text{ave}} &= \frac{1}{5} \int_0^5 V(t) dt = \frac{1}{5} \int_0^5 \frac{5}{4\pi} [1 - \cos(\frac{2}{5}\pi t)] dt = \frac{1}{4\pi} \int_0^5 [1 - \cos(\frac{2}{5}\pi t)] dt \\ &= \frac{1}{4\pi} [t - \frac{5}{2\pi} \sin(\frac{2}{5}\pi t)]_0^5 = \frac{1}{4\pi} [(5 - 0) - 0] = \frac{5}{4\pi} \approx 0.4 \text{ L} \end{aligned}$$

$$22. v_{\text{ave}} = \frac{1}{R-0} \int_0^R v(r) dr = \frac{1}{R} \int_0^R \frac{P}{4\eta l} (R^2 - r^2) dr = \frac{P}{4\eta l R} [R^2 r - \frac{1}{3} r^3]_0^R = \frac{P}{4\eta l R} (\frac{2}{3}) R^3 = \frac{PR^2}{6\eta l}$$

Since $v(r)$ is decreasing on $(0, R)$, $v_{\text{max}} = v(0) = \frac{PR^2}{4\eta l}$. Thus, $v_{\text{ave}} = \frac{2}{3} v_{\text{max}}$.

23. Let $F(x) = \int_a^x f(t) dt$ for x in $[a, b]$. Then F is continuous on $[a, b]$ and differentiable on (a, b) , so by the Mean Value Theorem there is a number c in (a, b) such that $F(b) - F(a) = F'(c)(b - a)$. But $F'(x) = f(x)$ by the Fundamental Theorem of Calculus. Therefore, $\int_a^b f(t) dt - 0 = f(c)(b - a)$.

$$\begin{aligned} 24. f_{\text{ave}} [a, b] &= \frac{1}{b-a} \int_a^b f(x) dx = \frac{1}{b-a} \int_a^c f(x) dx + \frac{1}{b-a} \int_c^b f(x) dx \\ &= \frac{c-a}{b-a} \left[\frac{1}{c-a} \int_a^c f(x) dx \right] + \frac{b-c}{b-a} \left[\frac{1}{b-c} \int_c^b f(x) dx \right] = \frac{c-a}{b-a} f_{\text{ave}} [a, c] + \frac{b-c}{b-a} f_{\text{ave}} [c, b] \end{aligned}$$

6 Review

CONCEPT CHECK

- (a) See Section 6.1, Figure 2 and Equations 6.1.1 and 6.1.2.
(b) Instead of using “top minus bottom” and integrating from left to right, we use “right minus left” and integrate from bottom to top. See Figures 11 and 12 in Section 6.1.
- The numerical value of the area represents the number of meters by which Sue is ahead of Kathy after 1 minute.

3. (a) See the discussion in Section 6.2, near Figures 2 and 3, ending in the Definition of Volume.
- (b) See the discussion between Examples 5 and 6 in Section 6.2. If the cross-section is a disk, find the radius in terms of x or y and use $A = \pi(\text{radius})^2$. If the cross-section is a washer, find the inner radius r_{in} and outer radius r_{out} and use $A = \pi(r_{\text{out}}^2) - \pi(r_{\text{in}}^2)$.
4. (a) $V = 2\pi r h \Delta r = (\text{circumference}) (\text{height}) (\text{thickness})$
- (b) For a typical shell, find the circumference and height in terms of x or y and calculate $V = \int_a^b (\text{circumference}) (\text{height}) (dx \text{ or } dy)$, where a and b are the limits on x or y .
- (c) Sometimes slicing produces washers or disks whose radii are difficult (or impossible) to find explicitly. On other occasions, the cylindrical shell method leads to an easier integral than slicing does.
5. $\int_0^6 f(x) dx$ represents the amount of work done. Its units are newton-meters, or joules.
6. (a) The average value of a function f on an interval $[a, b]$ is $f_{\text{ave}} = \frac{1}{b-a} \int_a^b f(x) dx$.
- (b) The Mean Value Theorem for Integrals says that there is a number c at which the value of f is exactly equal to the average value of the function, that is, $f(c) = f_{\text{ave}}$. For a geometric interpretation of the Mean Value Theorem for Integrals, see Figure 2 in Section 6.5 and the discussion that accompanies it.

EXERCISES

1. $0 = x^2 - x - 6 = (x - 3)(x + 2) \Leftrightarrow x = 3 \text{ or } -2$. So

$$\begin{aligned} A &= \int_{-2}^3 [0 - (x^2 - x - 6)] dx = \int_{-2}^3 (-x^2 + x + 6) dx \\ &= \left[-\frac{1}{3}x^3 + \frac{1}{2}x^2 + 6x\right]_{-2}^3 \\ &= \left(-9 + \frac{9}{2} + 18\right) - \left(\frac{8}{3} + 2 - 12\right) \\ &= \frac{125}{6} \end{aligned}$$

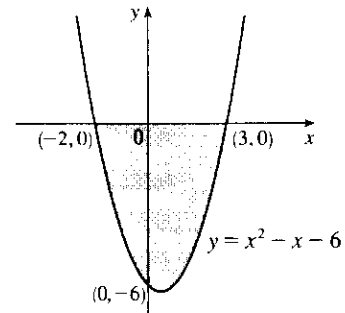

2. $20 - x^2 = x^2 - 12 \Leftrightarrow 32 = 2x^2 \Leftrightarrow x^2 = 16 \Leftrightarrow x = \pm 4$.
So

$$\begin{aligned} A &= \int_{-4}^4 [(20 - x^2) - (x^2 - 12)] dx = \int_{-4}^4 (32 - 2x^2) dx \\ &= 2 \int_0^4 (32 - 2x^2) dx \quad [\text{even function}] \\ &= 2 \left[32x - \frac{2}{3}x^3\right]_0^4 \\ &= 2 \left(128 - \frac{128}{3}\right) = \frac{512}{3} \end{aligned}$$

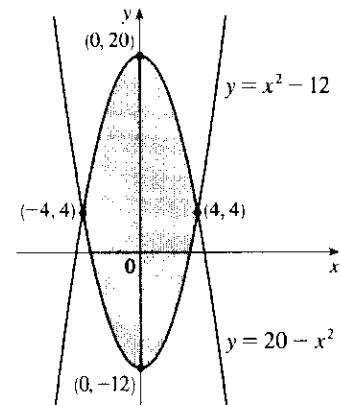

3. $1 - x^2 = 1 - \sqrt{x} \Leftrightarrow -x^2 = -\sqrt{x} \Leftrightarrow x^2 = \sqrt{x} \Rightarrow x^4 = x$
 $\Rightarrow x^4 - x = 0 \Rightarrow x(x^3 - 1) = 0 \Rightarrow$
 $x(x - 1)(x^2 + x + 1) = 0 \Rightarrow x = 0 \text{ or } 1.$ So

$$A = \int_0^1 [(1 - x^2) - (1 - \sqrt{x})] dx = \int_0^1 (\sqrt{x} - x^2) dx$$

$$= \left[\frac{2}{3}x^{3/2} - \frac{1}{3}x^3 \right]_0^1 = \frac{2}{3} - \frac{1}{3} = \frac{1}{3}$$

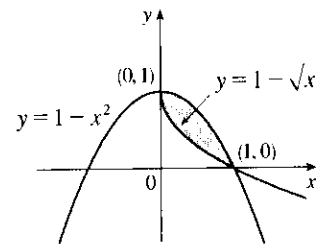

4. $y^2 + 3y = -y \Leftrightarrow y^2 + 4y = 0 \Leftrightarrow y(y + 4) = 0 \Leftrightarrow$
 $y = 0 \text{ or } -4.$

$$A = \int_{-4}^0 [-y - (y^2 + 3y)] dy = \int_{-4}^0 (-y^2 - 4y) dy$$

$$= \left[-\frac{1}{3}y^3 - 2y^2 \right]_{-4}^0 = 0 - \left(\frac{64}{3} - 32 \right) = \frac{32}{3}$$

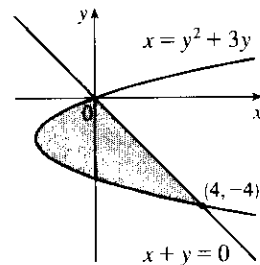

5. $A = \int_0^2 \left[\sin\left(\frac{\pi x}{2}\right) - (x^2 - 2x) \right] dx$
 $= \left[-\frac{2}{\pi} \cos\left(\frac{\pi x}{2}\right) - \frac{1}{3}x^3 + x^2 \right]_0^2$
 $= \left(\frac{2}{\pi} - \frac{8}{3} + 4 \right) - \left(-\frac{2}{\pi} - 0 + 0 \right) = \frac{4}{3} + \frac{4}{\pi}$

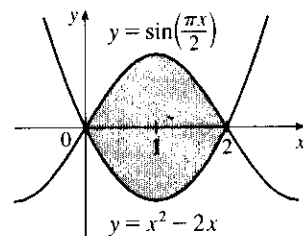

6. $A = \int_0^1 (\sqrt{x} - x^2) dx + \int_1^2 (x^2 - \sqrt{x}) dx$
 $= \left[\frac{2}{3}x^{3/2} - \frac{1}{3}x^3 \right]_0^1 + \left[\frac{1}{3}x^3 - \frac{2}{3}x^{3/2} \right]_1^2$
 $= \left[\left(\frac{2}{3} - \frac{1}{3} \right) - 0 \right] + \left[\left(\frac{8}{3} - \frac{4}{3}\sqrt{2} \right) - \left(\frac{1}{3} - \frac{2}{3} \right) \right]$
 $= \frac{10}{3} - \frac{4}{3}\sqrt{2}$

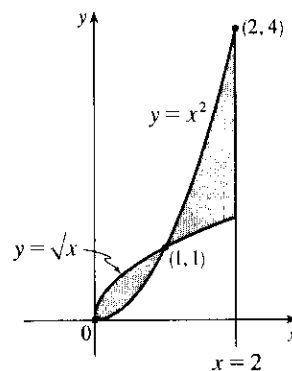

7. Using washers with inner radius x^2 and outer radius $2x$, we have

$$V = \pi \int_0^2 [(2x)^2 - (x^2)^2] dx = \pi \int_0^2 (4x^2 - x^4) dx$$

$$= \pi \left[\frac{4}{3}x^3 - \frac{1}{5}x^5 \right]_0^2 = \pi \left(\frac{32}{3} - \frac{32}{5} \right) = 32\pi \cdot \frac{2}{15}$$

$$= \frac{64\pi}{15}$$

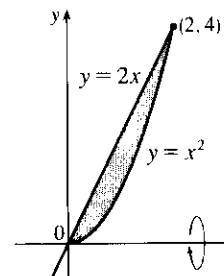

$$8. \quad 1 + y^2 = y + 3 \Leftrightarrow y^2 - y - 2 = 0 \Leftrightarrow (y - 2)(y + 1) = 0 \Leftrightarrow y = 2 \text{ or } -1.$$

$$\begin{aligned} V &= \pi \int_{-1}^2 [(y + 3)^2 - (1 + y^2)^2] dy \\ &= \pi \int_{-1}^2 (y^2 + 6y + 9 - 1 - 2y^2 - y^4) dy \\ &= \pi \int_{-1}^2 (8 + 6y - y^2 - y^4) dy = \pi \left[8y + 3y^2 - \frac{1}{3}y^3 - \frac{1}{5}y^5 \right]_{-1}^2 \\ &= \pi \left[\left(16 + 12 - \frac{8}{3} - \frac{32}{5} \right) - \left(-8 + 3 + \frac{1}{3} + \frac{1}{5} \right) \right] \\ &= \pi \left(33 - \frac{9}{3} - \frac{33}{5} \right) = \frac{117\pi}{5} \end{aligned}$$

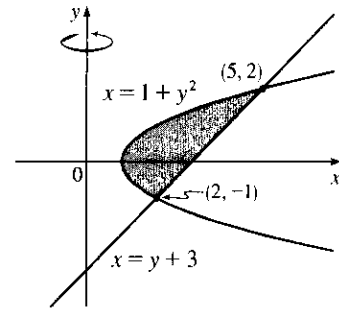

$$\begin{aligned} 9. \quad V &= \pi \int_{-3}^3 \left\{ [(9 - y^2) - (-1)]^2 - [0 - (-1)]^2 \right\} dy \\ &= 2\pi \int_0^3 [(10 - y^2)^2 - 1] dy \\ &= 2\pi \int_0^3 (100 - 20y^2 + y^4 - 1) dy \\ &= 2\pi \int_0^3 (99 - 20y^2 + y^4) dy = 2\pi \left[99y - \frac{20}{3}y^3 + \frac{1}{5}y^5 \right]_0^3 \\ &= 2\pi \left(297 - 180 + \frac{243}{5} \right) = \frac{1656\pi}{5} \end{aligned}$$

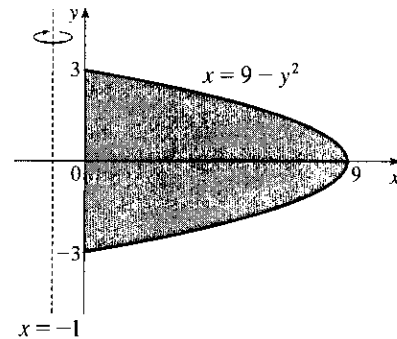

$$\begin{aligned} 10. \quad V &= \pi \int_{-2}^2 \left\{ [(9 - x^2) - (-1)]^2 - [(x^2 + 1) - (-1)]^2 \right\} dx \\ &= \pi \int_{-2}^2 [(10 - x^2)^2 - (x^2 + 2)^2] dx \\ &= 2\pi \int_0^2 (96 - 24x^2) dx = 48\pi \int_0^2 (4 - x^2) dx \\ &= 48\pi \left[4x - \frac{1}{3}x^3 \right]_0^2 = 48\pi \left(8 - \frac{8}{3} \right) = 256\pi \end{aligned}$$

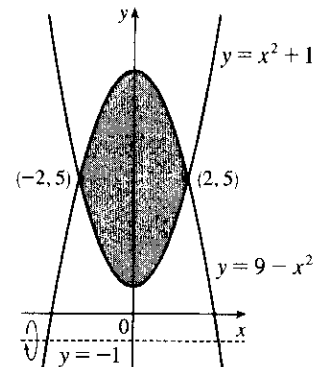

11. The graph of $x^2 - y^2 = a^2$ is a hyperbola with right and left branches. Solving for y gives us $y^2 = x^2 - a^2 \Rightarrow y = \pm\sqrt{x^2 - a^2}$. We'll use shells and the height of each shell is $\sqrt{x^2 - a^2} - (-\sqrt{x^2 - a^2}) = 2\sqrt{x^2 - a^2}$.

The volume is $V = \int_a^{a+h} 2\pi x \cdot 2\sqrt{x^2 - a^2} dx$. To evaluate, let $u = x^2 - a^2$, so $du = 2x dx$ and $x dx = \frac{1}{2} du$.

When $x = a$, $u = 0$, and when $x = a + h$,

$$u = (a + h)^2 - a^2 = a^2 + 2ah + h^2 - a^2 = 2ah + h^2.$$

$$\text{Thus, } V = 4\pi \int_0^{2ah+h^2} \sqrt{u} \left(\frac{1}{2} du \right) = 2\pi \left[\frac{2}{3} u^{3/2} \right]_0^{2ah+h^2} = \frac{4}{3}\pi (2ah + h^2)^{3/2}.$$

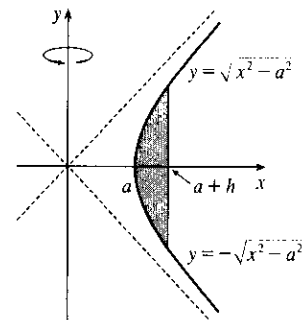

12. $V = \int_{3\pi/2}^{5\pi/2} 2\pi x \cos x \, dx$ [by the method of cylindrical shells]

13. $V = \int_0^1 \pi \left[(1-x^3)^2 - (1-x^2)^2 \right] dx$

14. $V = \int_0^2 2\pi(8-x^3)(2-x) \, dx$

15. (a) A cross-section is a washer with inner radius x^2 and outer radius x .

$$V = \int_0^1 \pi \left[(x)^2 - (x^2)^2 \right] dx = \int_0^1 \pi (x^2 - x^4) \, dx = \pi \left[\frac{1}{3}x^3 - \frac{1}{5}x^5 \right]_0^1 = \pi \left[\frac{1}{3} - \frac{1}{5} \right] = \frac{2\pi}{15}$$

(b) A cross-section is a washer with inner radius y and outer radius \sqrt{y} .

$$V = \int_0^1 \pi \left[(\sqrt{y})^2 - y^2 \right] dy = \int_0^1 \pi (y - y^2) \, dy = \pi \left[\frac{1}{2}y^2 - \frac{1}{3}y^3 \right]_0^1 = \pi \left[\frac{1}{2} - \frac{1}{3} \right] = \frac{\pi}{6}$$

(c) A cross-section is a washer with inner radius $2-x$ and outer radius $2-x^2$.

$$\begin{aligned} V &= \int_0^1 \pi \left[(2-x^2)^2 - (2-x)^2 \right] dx = \int_0^1 \pi (x^4 - 5x^2 + 4x) \, dx = \pi \left[\frac{1}{5}x^5 - \frac{5}{3}x^3 + 2x^2 \right]_0^1 \\ &= \pi \left[\frac{1}{5} - \frac{5}{3} + 2 \right] = \frac{8\pi}{15} \end{aligned}$$

16. (a) $A = \int_0^1 (2x - x^2 - x^3) \, dx = \left[x^2 - \frac{1}{3}x^3 - \frac{1}{4}x^4 \right]_0^1 = 1 - \frac{1}{3} - \frac{1}{4} = \frac{5}{12}$

(b) A cross-section is a washer with inner radius x^3 and outer radius $2x - x^2$, so its area is $\pi(2x - x^2)^2 - \pi(x^3)^2$.

$$\begin{aligned} V &= \int_0^1 A(x) \, dx = \int_0^1 \pi \left[(2x - x^2)^2 - (x^3)^2 \right] dx = \int_0^1 \pi (4x^2 - 4x^3 + x^4 - x^6) \, dx \\ &= \pi \left[\frac{4}{3}x^3 - x^4 + \frac{1}{5}x^5 - \frac{1}{7}x^7 \right]_0^1 = \pi \left(\frac{4}{3} - 1 + \frac{1}{5} - \frac{1}{7} \right) = \frac{41\pi}{105} \end{aligned}$$

(c) Using the method of cylindrical shells,

$$\begin{aligned} V &= \int_0^1 2\pi x(2x - x^2 - x^3) \, dx = \int_0^1 2\pi(2x^2 - x^3 - x^4) \, dx = 2\pi \left[\frac{2}{3}x^3 - \frac{1}{4}x^4 - \frac{1}{5}x^5 \right]_0^1 \\ &= 2\pi \left(\frac{2}{3} - \frac{1}{4} - \frac{1}{5} \right) = \frac{13\pi}{30}. \end{aligned}$$

17. (a) Using the Midpoint Rule on $[0, 1]$ with $f(x) = \tan(x^2)$ and $n = 4$, we estimate

$$A = \int_0^1 \tan(x^2) \, dx \approx \frac{1}{4} \left[\tan\left(\left(\frac{1}{8}\right)^2\right) + \tan\left(\left(\frac{3}{8}\right)^2\right) + \tan\left(\left(\frac{5}{8}\right)^2\right) + \tan\left(\left(\frac{7}{8}\right)^2\right) \right] \approx \frac{1}{4}(1.53) \approx 0.38$$

(b) Using the Midpoint Rule on $[0, 1]$ with $f(x) = \pi \tan^2(x^2)$ (for disks) and $n = 4$, we estimate

$$V = \int_0^1 f(x) \, dx \approx \frac{1}{4} \pi \left[\tan^2\left(\left(\frac{1}{8}\right)^2\right) + \tan^2\left(\left(\frac{3}{8}\right)^2\right) + \tan^2\left(\left(\frac{5}{8}\right)^2\right) + \tan^2\left(\left(\frac{7}{8}\right)^2\right) \right] \approx \frac{\pi}{4}(1.114) \approx 0.87$$

18. (a)

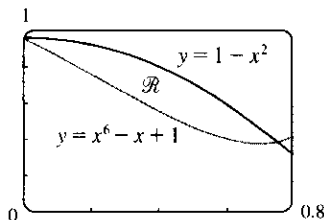

From the graph, we see that the curves intersect at $x = 0$ and at $x = a \approx 0.75$, with $1 - x^2 > x^6 - x + 1$ on $(0, a)$.

(b) The area of \mathcal{R} is

$$A = \int_0^a \left[(1-x^2) - (x^6 - x + 1) \right] dx = \left[-\frac{1}{3}x^3 - \frac{1}{7}x^7 + \frac{1}{2}x^2 \right]_0^a \approx 0.12$$

(c) Using washers, the volume generated when \mathcal{R} is rotated about the x -axis is

$$\begin{aligned} V &= \pi \int_0^a \left[(1-x^2)^2 - (x^6 - x + 1)^2 \right] dx = \pi \int_0^a (-x^{12} + 2x^7 - 2x^6 + x^4 - 3x^2 + 2x) \, dx \\ &= \pi \left[-\frac{1}{13}x^{13} + \frac{1}{4}x^8 - \frac{2}{7}x^7 + \frac{1}{5}x^5 - x^3 + x^2 \right]_0^a \approx 0.54 \end{aligned}$$

(d) Using shells, the volume generated when \mathcal{R} is rotated about the y -axis is

$$\begin{aligned} V &= \int_0^a 2\pi x [(1-x^2) - (x^6 - x + 1)] dx = 2\pi \int_0^a (-x^3 - x^7 + x^2) dx \\ &= 2\pi \left[-\frac{1}{4}x^4 - \frac{1}{8}x^8 + \frac{1}{3}x^3 \right]_0^a \approx 0.31 \end{aligned}$$

19. The solid is obtained by rotating the region $\mathcal{R} = \{(x, y) \mid 0 \leq x \leq \frac{\pi}{2}, 0 \leq y \leq \cos x\}$ about the y -axis.

20. The solid is obtained by rotating the region $\mathcal{R} = \{(x, y) \mid 0 \leq x \leq \frac{\pi}{2}, 0 \leq y \leq \sqrt{2} \cos x\}$ about the x -axis.

21. The solid is obtained by rotating the region $\mathcal{R} = \{(x, y) \mid 0 \leq y \leq 2, 0 \leq x \leq 4 - y^2\}$ about the x -axis.

22. The solid is obtained by rotating the region $\mathcal{R} = \{(x, y) \mid 0 \leq x \leq 1, 2 - \sqrt{x} \leq y \leq 2 - x^2\}$ about the x -axis.

Or: The solid is obtained by rotating the region $\mathcal{R} = \{(x, y) \mid 0 \leq x \leq 1, x^2 \leq y \leq \sqrt{x}\}$ about the line $y = 2$.

23. Take the base to be the disk $x^2 + y^2 \leq 9$. Then $V = \int_{-3}^3 A(x) dx$, where $A(x_0)$ is the area of the isosceles right

triangle whose hypotenuse lies along the line $x = x_0$ in the xy -plane. The length of the hypotenuse is $2\sqrt{9 - x^2}$

and the length of each leg is $\sqrt{2}\sqrt{9 - x^2}$. $A(x) = \frac{1}{2}(\sqrt{2}\sqrt{9 - x^2})^2 = 9 - x^2$, so

$$V = 2 \int_0^3 A(x) dx = 2 \int_0^3 (9 - x^2) dx = 2 \left[9x - \frac{1}{3}x^3 \right]_0^3 = 2(27 - 9) = 36.$$

24. $V = \int_{-1}^1 A(x) dx = 2 \int_0^1 A(x) dx = 2 \int_0^1 [(2 - x^2) - x^2]^2 dx = 2 \int_0^1 [2(1 - x^2)]^2 dx$

$$= 8 \int_0^1 (1 - 2x^2 + x^4) dx = 8 \left[x - \frac{2}{3}x^3 + \frac{1}{5}x^5 \right]_0^1 = 8 \left(1 - \frac{2}{3} + \frac{1}{5} \right) = \frac{64}{15}$$

25. Equilateral triangles with sides measuring $\frac{1}{4}x$ meters have height $\frac{1}{4}x \sin 60^\circ = \frac{\sqrt{3}}{8}x$. Therefore,

$$A(x) = \frac{1}{2} \cdot \frac{1}{4}x \cdot \frac{\sqrt{3}}{8}x = \frac{\sqrt{3}}{64}x^2. \quad V = \int_0^{20} A(x) dx = \frac{\sqrt{3}}{64} \int_0^{20} x^2 dx = \frac{\sqrt{3}}{64} \left[\frac{1}{3}x^3 \right]_0^{20} = \frac{8000\sqrt{3}}{64 \cdot 3} = \frac{125\sqrt{3}}{3} \text{ m}^3.$$

26. (a) By the symmetry of the problem, we consider only the solid to the right of the origin. The semicircular

cross-sections perpendicular to the x -axis have radius $1 - x$, so $A(x) = \frac{1}{2}\pi(1 - x)^2$. Now we can calculate

$$V = 2 \int_0^1 A(x) dx = 2 \int_0^1 \frac{1}{2}\pi(1 - x)^2 dx = \int_0^1 \pi(1 - x)^2 dx = -\frac{\pi}{3}[(1 - x)^3]_0^1 = \frac{\pi}{3}.$$

(b) Cut the solid with a plane perpendicular to the x -axis and passing through the y -axis. Fold the half of the solid in

the region $x \leq 0$ under the xy -plane so that the point $(-1, 0)$ comes around and touches the point $(1, 0)$. The

resulting solid is a right circular cone of radius 1 with vertex at $(x, y, z) = (1, 0, 0)$ and with its base in the

yz -plane, centered at the origin. The volume of this cone is $\frac{1}{3}\pi r^2 h = \frac{1}{3}\pi \cdot 1^2 \cdot 1 = \frac{\pi}{3}$.

27. $f(x) = kx \Rightarrow 30 \text{ N} = k(15 - 12) \text{ cm} \Rightarrow k = 10 \text{ N/cm} = 1000 \text{ N/m}$. $20 \text{ cm} - 12 \text{ cm} = 0.08 \text{ m} \Rightarrow$

$$W = \int_0^{0.08} kx dx = 1000 \int_0^{0.08} x dx = 500 [x^2]_0^{0.08} = 500(0.08)^2 = 3.2 \text{ N}\cdot\text{m} = 3.2 \text{ J}.$$

28. The work needed to raise the elevator alone is $1600 \text{ lb} \times 30 \text{ ft} = 48,000 \text{ ft}\cdot\text{lb}$. The work needed to raise the bottom 170 ft of cable is $170 \text{ ft} \times 10 \text{ lb/ft} \times 30 \text{ ft} = 51,000 \text{ ft}\cdot\text{lb}$. The work needed to raise the top 30 ft of cable is

$$\int_0^{30} 10x \, dx = [5x^2]_0^{30} = 5 \cdot 900 = 4500 \text{ ft}\cdot\text{lb}.$$

Adding these, we see that the total work needed is $48,000 + 51,000 + 4,500 = 103,500 \text{ ft}\cdot\text{lb}$.

29. (a) The parabola has equation $y = ax^2$ with vertex at the origin and passing through $(4, 4)$. $4 = a \cdot 4^2 \Rightarrow a = \frac{1}{4} \Rightarrow y = \frac{1}{4}x^2 \Rightarrow x^2 = 4y \Rightarrow x = 2\sqrt{y}$. Each circular disk has radius $2\sqrt{y}$ and is moved $4 - y$ ft.

$$\begin{aligned} W &= \int_0^4 \pi (2\sqrt{y})^2 62.5 (4 - y) \, dy = 250\pi \int_0^4 y(4 - y) \, dy \\ &= 250\pi \left[2y^2 - \frac{1}{3}y^3 \right]_0^4 = 250\pi \left(32 - \frac{64}{3} \right) = \frac{8000\pi}{3} \approx 8378 \text{ ft}\cdot\text{lb} \end{aligned}$$

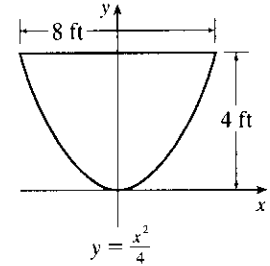

- (b) In part (a) we knew the final water level (0) but not the amount of work done. Here we use the same equation, except with the work fixed, and the lower limit of integration (that is, the final water level — call it h)

$$\begin{aligned} \text{unknown: } W &= 4000 \Leftrightarrow 250\pi \left[2y^2 - \frac{1}{3}y^3 \right]_h^4 = 4000 \Leftrightarrow \\ \frac{16}{\pi} &= \left[\left(32 - \frac{64}{3} \right) - \left(2h^2 - \frac{1}{3}h^3 \right) \right] \Leftrightarrow h^3 - 6h^2 + 32 - \frac{48}{\pi} = 0. \end{aligned}$$

We graph the function $f(h) = h^3 - 6h^2 + 32 - \frac{48}{\pi}$ on the interval $[0, 4]$ to see where it is 0. From the graph, $f(h) = 0$ for $h \approx 2.1$. So the depth of water remaining is about 2.1 ft.

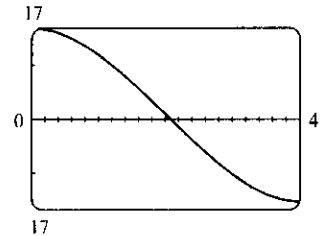

30. $f_{\text{ave}} = \frac{1}{10-0} \int_0^{10} t \sin(t^2) \, dt = \frac{1}{10} \int_0^{100} \sin u \left(\frac{1}{2} du \right) \quad [u = t^2, du = 2t \, dt]$

$$= \frac{1}{20} \left[-\cos u \right]_0^{100} = \frac{1}{20} (-\cos 100 + \cos 0) = \frac{1}{20} (1 - \cos 100) \approx 0.007$$

31. $\lim_{h \rightarrow 0} f_{\text{ave}} = \lim_{h \rightarrow 0} \frac{1}{(x+h) - x} \int_x^{x+h} f(t) \, dt = \lim_{h \rightarrow 0} \frac{F(x+h) - F(x)}{h}$, where $F(x) = \int_a^x f(t) \, dt$. But we recognize this limit as being $F'(x)$ by the definition of a derivative. Therefore, $\lim_{h \rightarrow 0} f_{\text{ave}} = F'(x) = f(x)$ by FTC1.

32. (a) \mathcal{R}_1 is the region below the graph of $y = x^2$ and above the x -axis between $x = 0$ and $x = b$, and \mathcal{R}_2 is the region to the left of the graph of $x = \sqrt{y}$ and to the right of the y -axis between $y = 0$ and $y = b^2$. So the area of \mathcal{R}_1 is $A_1 = \int_0^b x^2 \, dx = \left[\frac{1}{3}x^3 \right]_0^b = \frac{1}{3}b^3$, and the area of \mathcal{R}_2 is $A_2 = \int_0^{b^2} \sqrt{y} \, dy = \left[\frac{2}{3}y^{3/2} \right]_0^{b^2} = \frac{2}{3}b^3$. So there is no solution to $A_1 = A_2$ for $b \neq 0$.

(b) Using disks, we calculate the volume of rotation of \mathcal{R}_1 about the x -axis to be $V_{1,x} = \pi \int_0^b (x^2)^2 dx = \frac{1}{5} \pi b^5$.

Using cylindrical shells, we calculate the volume of rotation of \mathcal{R}_1 about the y -axis to be

$$V_{1,y} = 2\pi \int_0^b x(x^2) dx = 2\pi \left[\frac{1}{4} x^4 \right]_0^b = \frac{1}{2} \pi b^4. \text{ So } V_{1,x} = V_{1,y} \Leftrightarrow \frac{1}{5} \pi b^5 = \frac{1}{2} \pi b^4 \Leftrightarrow 2b = 5 \Leftrightarrow$$

$b = \frac{5}{2}$. So the volumes of rotation about the x - and y -axes are the same for $b = \frac{5}{2}$.

(c) We use cylindrical shells to calculate the volume of rotation of \mathcal{R}_2 about the x -axis:

$$\mathcal{R}_{2,x} = 2\pi \int_0^{b^2} y(\sqrt{y}) dy = 2\pi \left[\frac{2}{5} y^{5/2} \right]_0^{b^2} = \frac{4}{5} \pi b^5. \text{ We already know the volume of rotation of } \mathcal{R}_1 \text{ about the}$$

x -axis from part (b), and $\mathcal{R}_{1,x} = \mathcal{R}_{2,x} \Leftrightarrow \frac{1}{5} \pi b^5 = \frac{4}{5} \pi b^5$, which has no solution for $b \neq 0$.

(d) We use disks to calculate the volume of rotation of \mathcal{R}_2 about the y -axis:

$$\mathcal{R}_{2,y} = \pi \int_0^{b^2} (\sqrt{y})^2 dy = \pi \left[\frac{1}{2} y^2 \right]_0^{b^2} = \frac{1}{2} \pi b^4. \text{ We know the volume of rotation of } \mathcal{R}_1 \text{ about the } y\text{-axis from}$$

part (b), and $\mathcal{R}_{1,y} = \mathcal{R}_{2,y} \Leftrightarrow \frac{1}{2} \pi b^4 = \frac{1}{2} \pi b^4$. But this equation is true for all b , so the volumes of rotation about the y -axis are equal for all values of b .

□ PROBLEMS PLUS

1. (a) The area under the graph of f from 0 to t is equal to $\int_0^t f(x) dx$, so the requirement is that $\int_0^t f(x) dx = t^3$ for all t . We differentiate both sides of this equation with respect to t (with the help of FTC1) to get $f(t) = 3t^2$.

This function is positive and continuous, as required.

- (b) The volume generated from $x = 0$ to $x = b$ is $\int_0^b \pi[f(x)]^2 dx$. Hence, we are given that $b^2 = \int_0^b \pi[f(x)]^2 dx$ for all $b > 0$. Differentiating both sides of this equation with respect to b using the Fundamental Theorem of Calculus gives $2b = \pi[f(b)]^2 \Rightarrow f(b) = \sqrt{2b/\pi}$, since f is positive. Therefore, $f(x) = \sqrt{2x/\pi}$.

2. The total area of the region bounded by the parabola

$y = x - x^2 = x(1 - x)$ and the x -axis is

$$\int_0^1 (x - x^2) dx = \left[\frac{1}{2}x^2 - \frac{1}{3}x^3 \right]_0^1 = \frac{1}{6}.$$

Let the slope of the line we are looking for be m . Then the area above this

line but below the parabola is $\int_0^a [(x - x^2) - mx] dx$, where a is the

x -coordinate of the point of intersection of the line and the parabola. We

find the point of intersection by solving the equation $x - x^2 = mx \Leftrightarrow$

$1 - x = m \Leftrightarrow x = 1 - m$. So the value of a is $1 - m$, and

$$\begin{aligned} \int_0^{1-m} [(x - x^2) - mx] dx &= \int_0^{1-m} [(1 - m)x - x^2] dx = \left[\frac{1}{2}(1 - m)x^2 - \frac{1}{3}x^3 \right]_0^{1-m} \\ &= \frac{1}{2}(1 - m)(1 - m)^2 - \frac{1}{3}(1 - m)^3 = \frac{1}{6}(1 - m)^3 \end{aligned}$$

We want this to be half of $\frac{1}{6}$, so $\frac{1}{6}(1 - m)^3 = \frac{1}{12} \Leftrightarrow (1 - m)^3 = \frac{6}{12} \Leftrightarrow$

$1 - m = \sqrt[3]{\frac{1}{2}} \Leftrightarrow m = 1 - \frac{1}{\sqrt[3]{2}}$. So the slope of the required line is $1 - \frac{1}{\sqrt[3]{2}} \approx 0.206$.

3. Let a and b be the x -coordinates of the points where the line intersects the

curve. From the figure, $R_1 = R_2 \Rightarrow$

$$\int_0^a [c - (8x - 27x^3)] dx = \int_a^b [(8x - 27x^3) - c] dx$$

$$[cx - 4x^2 + \frac{27}{4}x^4]_0^a = [4x^2 - \frac{27}{4}x^4 - cx]_a^b$$

$$ac - 4a^2 + \frac{27}{4}a^4 = (4b^2 - \frac{27}{4}b^4 - bc) - (4a^2 - \frac{27}{4}a^4 - ac)$$

$$0 = 4b^2 - \frac{27}{4}b^4 - bc = 4b^2 - \frac{27}{4}b^4 - b(8b - 27b^3)$$

$$= 4b^2 - \frac{27}{4}b^4 - 8b^2 + 27b^4 = \frac{81}{4}b^4 - 4b^2$$

$$= b^2 \left(\frac{81}{4}b^2 - 4 \right)$$

So for $b > 0$, $b^2 = \frac{16}{81} \Rightarrow b = \frac{4}{9}$. Thus, $c = 8b - 27b^3 = 8\left(\frac{4}{9}\right) - 27\left(\frac{64}{729}\right) = \frac{32}{9} - \frac{64}{27} = \frac{32}{27}$.

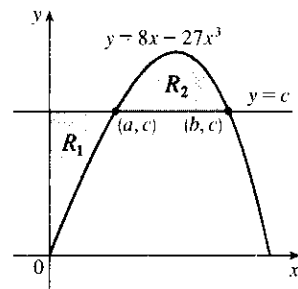
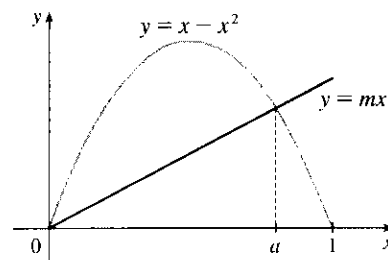

4. (a) Take slices perpendicular to the line through the center C of the bottom of the glass and the point P where the top surface of the water meets the bottom of the glass.

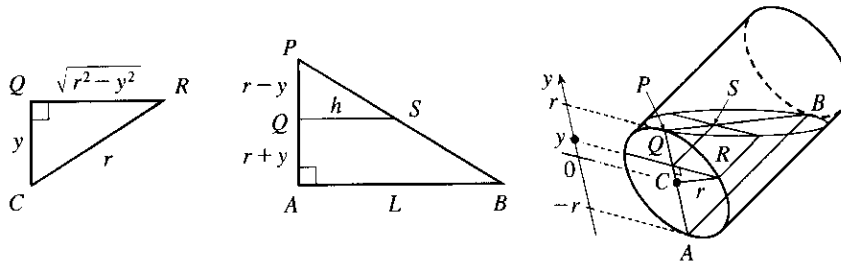

A typical rectangular cross-section y units above the axis of the glass has width $2|QR| = 2\sqrt{r^2 - y^2}$ and length $h = |QS| = \frac{L}{2r}(r - y)$. [Triangles PQS and PAB are similar, so $\frac{h}{L} = \frac{|PQ|}{|PA|} = \frac{r - y}{2r}$.] Thus,

$$\begin{aligned} V &= \int_{-r}^r 2\sqrt{r^2 - y^2} \cdot \frac{L}{2r}(r - y) dy = L \int_{-r}^r \left(1 - \frac{y}{r}\right) \sqrt{r^2 - y^2} dy \\ &= L \int_{-r}^r \sqrt{r^2 - y^2} dy - \frac{L}{r} \int_{-r}^r y\sqrt{r^2 - y^2} dy \\ &= L \cdot \frac{\pi r^2}{2} - \frac{L}{r} \cdot 0 \quad \left[\begin{array}{l} \text{the first integral is the area of a semicircle of radius } r, \\ \text{and the second has an odd integrand} \end{array} \right] = \frac{\pi r^2 L}{2} \end{aligned}$$

- (b) Slice parallel to the plane through the axis of the glass and the point of contact P . (This is the plane determined by P , B , and C in the figure.) $STUV$ is a typical trapezoidal slice. With respect to an x -axis with origin at C as shown, if S and V have x -coordinate x , then $|SV| = 2\sqrt{r^2 - x^2}$. Projecting the trapezoid $STUV$ onto the plane of the triangle PAB (call the projection $S'T'U'V'$), we see that $|AP| = 2r$, $|SV| = 2\sqrt{r^2 - x^2}$, and $|S'P| = |V'A| = \frac{1}{2}(|AP| - |SV|) = r - \sqrt{r^2 - x^2}$.

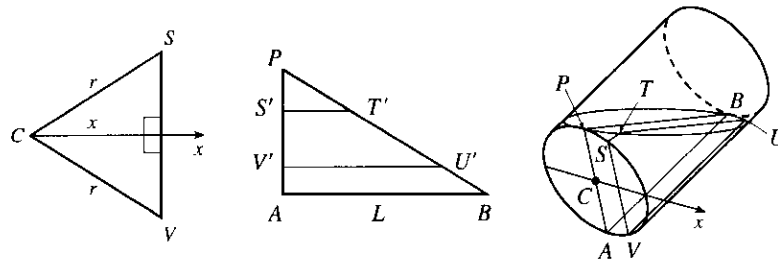

By similar triangles, $\frac{|ST|}{|S'P|} = \frac{|AB|}{|AP|}$, so $|ST| = (r - \sqrt{r^2 - x^2}) \cdot \frac{L}{2r}$. In the same way, we find that

$$\frac{|VU|}{|V'P|} = \frac{|AB|}{|AP|}, \text{ so } |VU| = |V'P| \cdot \frac{L}{2r} = (|AP| - |V'A|) \cdot \frac{L}{2r} = (r + \sqrt{r^2 - x^2}) \cdot \frac{L}{2r}.$$

The area $A(x)$ of the trapezoid $STUV$ is $\frac{1}{2}|SV| \cdot (|ST| + |VU|)$; that is,

$$A(x) = \frac{1}{2} \cdot 2\sqrt{r^2 - x^2} \cdot \left[(r - \sqrt{r^2 - x^2}) \cdot \frac{L}{2r} + (r + \sqrt{r^2 - x^2}) \cdot \frac{L}{2r} \right] = L\sqrt{r^2 - x^2}. \text{ Thus,}$$

$$V = \int_{-r}^r A(x) dx = L \int_{-r}^r \sqrt{r^2 - x^2} dx = L \cdot \frac{\pi r^2}{2} = \frac{\pi r^2 L}{2}.$$

- (c) See the computation of V in part (a) or part (b).

(d) The volume of the water is exactly half the volume of the cylindrical glass, so $V = \frac{1}{2}\pi r^2 L$.

(e)

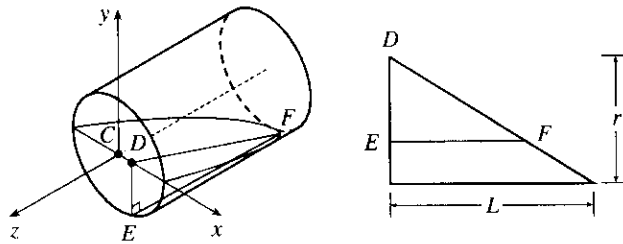

Choose x -, y -, and z -axes as shown in the figure. Then slices perpendicular to the x -axis are triangular, slices perpendicular to the y -axis are rectangular, and slices perpendicular to the z -axis are segments of circles. Using triangular slices, we find that the area $A(x)$ of a typical slice DEF , where D has x -coordinate x , is given by

$$A(x) = \frac{1}{2}|DE| \cdot |EF| = \frac{1}{2}|DE| \cdot \left(\frac{L}{r}|DE|\right) = \frac{L}{2r}|DE|^2 = \frac{L}{2r}(r^2 - x^2). \text{ Thus,}$$

$$\begin{aligned} V &= \int_{-r}^r A(x) dx = \frac{L}{2r} \int_{-r}^r (r^2 - x^2) dx = \frac{L}{r} \int_0^r (r^2 - x^2) dx = \frac{L}{r} \left[r^2 x - \frac{x^3}{3} \right]_0^r \\ &= \frac{L}{r} \left(r^3 - \frac{r^3}{3} \right) = \frac{L}{r} \cdot \frac{2}{3} r^3 = \frac{2}{3} r^2 L \text{ [This is } 2/(3\pi) \approx 0.21 \text{ of the volume of the glass.]} \end{aligned}$$

5. (a) $V = \pi h^2(r - h/3) = \frac{1}{3}\pi h^2(3r - h)$. See the solution to Exercise 6.2.49.

(b) The smaller segment has height $h = 1 - x$ and so by part (a) its volume is

$$\begin{aligned} V &= \frac{1}{3}\pi(1-x)^2 [3(1) - (1-x)] = \frac{1}{3}\pi(x-1)^2(x+2). \text{ This volume must be } \frac{1}{3} \text{ of the total volume of the} \\ &\text{sphere, which is } \frac{4}{3}\pi(1)^3. \text{ So } \frac{1}{3}\pi(x-1)^2(x+2) = \frac{1}{3}\left(\frac{4}{3}\pi\right) \Rightarrow (x^2 - 2x + 1)(x+2) = \frac{4}{3} \Rightarrow \\ &x^3 - 3x + 2 = \frac{4}{3} \Rightarrow 3x^3 - 9x + 2 = 0. \text{ Using Newton's method with } f(x) = 3x^3 - 9x + 2, \\ &f'(x) = 9x^2 - 9, \text{ we get } x_{n+1} = x_n - \frac{3x_n^3 - 9x_n + 2}{9x_n^2 - 9}. \text{ Taking } x_1 = 0, \text{ we get } x_2 \approx 0.2222, \text{ and} \\ &x_3 \approx 0.2261 \approx x_4, \text{ so, correct to four decimal places, } x \approx 0.2261. \end{aligned}$$

(c) With $r = 0.5$ and $s = 0.75$, the equation $x^3 - 3rx^2 + 4r^3s = 0$ becomes $x^3 - 3(0.5)x^2 + 4(0.5)^3(0.75) = 0$
 $\Rightarrow x^3 - \frac{3}{2}x^2 + 4\left(\frac{1}{8}\right)\frac{3}{4} = 0 \Rightarrow 8x^3 - 12x^2 + 3 = 0$. We use Newton's method with

$$f(x) = 8x^3 - 12x^2 + 3, f'(x) = 24x^2 - 24x, \text{ so } x_{n+1} = x_n - \frac{8x_n^3 - 12x_n^2 + 3}{24x_n^2 - 24x_n}. \text{ Take } x_1 = 0.5. \text{ Then}$$

$$x_2 \approx 0.6667, \text{ and } x_3 \approx 0.6736 \approx x_4. \text{ So to four decimal places the depth is } 0.6736 \text{ m.}$$

(d) (i) From part (a) with $r = 5$ in., the volume of water in the bowl is

$$\begin{aligned} V &= \frac{1}{3}\pi h^2(3r - h) = \frac{1}{3}\pi h^2(15 - h) = 5\pi h^2 - \frac{1}{3}\pi h^3. \text{ We are given that } \frac{dV}{dt} = 0.2 \text{ m}^3/\text{s} \text{ and we want to} \\ &\text{find } \frac{dh}{dt} \text{ when } h = 3. \text{ Now } \frac{dV}{dt} = 10\pi h \frac{dh}{dt} - \pi h^2 \frac{dh}{dt}, \text{ so } \frac{dh}{dt} = \frac{0.2}{\pi(10h - h^2)}. \text{ When } h = 3, \text{ we have} \\ &\frac{dh}{dt} = \frac{0.2}{\pi(10 \cdot 3 - 3^2)} = \frac{1}{105\pi} \approx 0.003 \text{ in/s.} \end{aligned}$$

(ii) From part (a), the volume of water required to fill the bowl from the instant that the water is 4 in. deep is

$$V = \frac{1}{2} \cdot \frac{4}{3} \pi (5)^3 - \frac{1}{3} \pi (4)^2 (15 - 4) = \frac{2}{3} \cdot 125\pi - \frac{16}{3} \cdot 11\pi = \frac{74}{3} \pi.$$

To find the time required to fill the bowl we divide this volume by the rate: Time = $\frac{74\pi/3}{0.2} = \frac{370\pi}{3} \approx 387 \text{ s} \approx 6.5 \text{ min}$

6. (a) The volume above the surface is $\int_0^{L-h} A(y) dy = \int_{-h}^{L-h} A(y) dy - \int_{-h}^0 A(y) dy$. So the proportion of volume

above the surface is $\frac{\int_0^{L-h} A(y) dy}{\int_{-h}^{L-h} A(y) dy} = \frac{\int_{-h}^{L-h} A(y) dy - \int_{-h}^0 A(y) dy}{\int_{-h}^{L-h} A(y) dy}$. Now by Archimedes' Principle, we

have $F = W \Rightarrow \rho_f g \int_{-h}^0 A(y) dy = \rho_0 g \int_{-h}^{L-h} A(y) dy$, so $\int_{-h}^0 A(y) dy = (\rho_0/\rho_f) \int_{-h}^{L-h} A(y) dy$.

Therefore, $\frac{\int_0^{L-h} A(y) dy}{\int_{-h}^{L-h} A(y) dy} = \frac{\int_{-h}^{L-h} A(y) dy - (\rho_0/\rho_f) \int_{-h}^{L-h} A(y) dy}{\int_{-h}^{L-h} A(y) dy} = \frac{\rho_f - \rho_0}{\rho_f}$, so the percentage of

volume above the surface is $100 \left(\frac{\rho_f - \rho_0}{\rho_f} \right) \%$.

(b) For an iceberg, the percentage of volume above the surface is $100 \left(\frac{1030 - 917}{1030} \right) \% \approx 11\%$.

(c) No, the water does not overflow. Let V_i be the volume of the ice cube, and let V_w be the volume of the water which results from the melting. Then by the formula derived in part (a), the volume of ice above the surface of the water is $[(\rho_f - \rho_0)/\rho_f] V_i$, so the volume below the surface is $V_i - [(\rho_f - \rho_0)/\rho_f] V_i = (\rho_0/\rho_f) V_i$.

Now the mass of the ice cube is the same as the mass of the water which is created when it melts, namely

$m = \rho_0 V_i = \rho_f V_w \Rightarrow V_w = (\rho_0/\rho_f) V_i$. So when the ice cube melts, the volume of the resulting water is the same as the underwater volume of the ice cube, and so the water does not overflow.

(d)

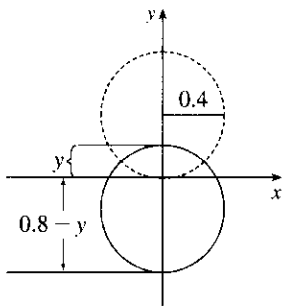

The figure shows the instant when the height of the exposed part of the ball is y . Using the formula in Problem 5(a) with $r = 0.4$ and

$h = 0.8 - y$, we see that the volume of the submerged part of the

sphere is $\frac{1}{3} \pi (0.8 - y)^2 [1.2 - (0.8 - y)]$, so its weight is

$1000g \cdot \frac{1}{3} \pi s^2 (1.2 - s)$, where $s = 0.8 - y$. Then the work done to submerge the sphere is

$$\begin{aligned} W &= \int_0^{0.8} g \frac{1000}{3} \pi s^2 (1.2 - s) ds = g \frac{1000}{3} \pi \int_0^{0.8} (1.2s^2 - s^3) ds \\ &= g \frac{1000}{3} \pi \left[0.4s^3 - \frac{1}{4}s^4 \right]_0^{0.8} = g \frac{1000}{3} \pi (0.2048 - 0.1024) \\ &= 9.8 \frac{1000}{3} \pi (0.1024) \approx 1.05 \times 10^3 \text{ joules} \end{aligned}$$

7. We are given that the rate of change of the volume of water is $\frac{dV}{dt} = -kA(x)$, where k is some positive constant and $A(x)$ is the area of the surface when the water has depth x . Now we are concerned with the rate of change of

the depth of the water with respect to time, that is, $\frac{dx}{dt}$. But by the Chain Rule, $\frac{dV}{dt} = \frac{dV}{dx} \frac{dx}{dt}$, so the first equation

can be written $\frac{dV}{dx} \frac{dx}{dt} = -kA(x)$ (*). Also, we know that the total volume of water up to a depth x is

$V(x) = \int_0^x A(s) ds$, where $A(s)$ is the area of a cross-section of the water at a depth s . Differentiating this equation with respect to x , we get $dV/dx = A(x)$. Substituting this into equation \star , we get $A(x)(dx/dt) = -kA(x) \Rightarrow dx/dt = -k$, a constant.

8. A typical sphere of radius r is shown in the figure. We wish to maximize the shaded volume V , which can be thought of as the volume of a hemisphere of radius r minus the volume of the spherical cap with height $h = 1 - \sqrt{1 - r^2}$ and radius 1.

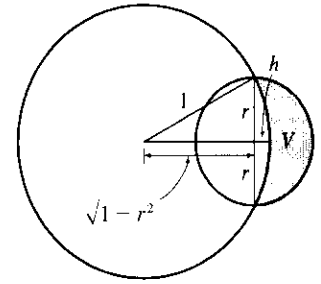

$$V = \frac{1}{2} \cdot \frac{4}{3} \pi r^3 - \frac{1}{3} \pi (1 - \sqrt{1 - r^2})^2 [3(1) - (1 - \sqrt{1 - r^2})] \quad [\text{by Problem 5(a)}]$$

$$= \frac{1}{3} \pi [2r^3 - (2 - 2\sqrt{1 - r^2} - r^2)(2 + \sqrt{1 - r^2})]$$

$$= \frac{1}{3} \pi [2r^3 - 2 + (r^2 + 2)\sqrt{1 - r^2}]$$

$$V' = \frac{1}{3} \pi \left[6r^2 + \frac{(r^2 + 2)(-r)}{\sqrt{1 - r^2}} + \sqrt{1 - r^2}(2r) \right] = \frac{1}{3} \pi \left[\frac{6r^2\sqrt{1 - r^2} - r(r^2 + 2) + 2r(1 - r^2)}{\sqrt{1 - r^2}} \right]$$

$$= \frac{1}{3} \pi \left(\frac{6r^2\sqrt{1 - r^2} - 3r^3}{\sqrt{1 - r^2}} \right) = \frac{\pi r^2(2\sqrt{1 - r^2} - r)}{\sqrt{1 - r^2}}$$

$V'(r) = 0 \Leftrightarrow 2\sqrt{1 - r^2} = r \Leftrightarrow 4 - 4r^2 = r^2 \Leftrightarrow r^2 = \frac{4}{5} \Leftrightarrow r = \frac{2}{\sqrt{5}} \approx 0.89$. Since $V'(r) > 0$ for $0 < r < \frac{2}{\sqrt{5}}$ and $V'(r) < 0$ for $\frac{2}{\sqrt{5}} < r < 1$, we know that V attains a maximum at $r = \frac{2}{\sqrt{5}}$.

9. We must find expressions for the areas A and B , and then set them equal and see what this says about the curve C . If $P = (a, 2a^2)$, then area A is just $\int_0^a (2x^2 - x^2) dx = \int_0^a x^2 dx = \frac{1}{3}a^3$. To find area B , we use y as the variable of integration. So we find the equation of the middle curve as a function of y : $y = 2x^2 \Leftrightarrow x = \sqrt{y/2}$,

since we are concerned with the first quadrant only. We can express area B as

$$\int_0^{2a^2} [\sqrt{y/2} - C(y)] dy = \left[\frac{4}{3}(y/2)^{3/2} \right]_0^{2a^2} - \int_0^{2a^2} C(y) dy = \frac{4}{3}a^3 - \int_0^{2a^2} C(y) dy$$

where $C(y)$ is the function with graph C . Setting $A = B$, we get $\frac{1}{3}a^3 = \frac{4}{3}a^3 - \int_0^{2a^2} C(y) dy \Leftrightarrow \int_0^{2a^2} C(y) dy = a^3$. Now we differentiate this equation with respect to a using the Chain Rule and the Fundamental Theorem:

$$C(2a^2)(4a) = 3a^2 \Rightarrow C(y) = \frac{3}{4} \sqrt{y/2}, \text{ where } y = 2a^2. \text{ Now we can solve for } y: x = \frac{3}{4} \sqrt{y/2} \Rightarrow$$

$$x^2 = \frac{9}{16}(y/2) \Rightarrow y = \frac{32}{9}x^2.$$

10. We want to find the volume of that part of the sphere which is below the surface of the water. As we can see from the diagram, this region is a cap of a sphere with radius r and height $r + d$. If we can find an expression for d in terms of h , r and θ , then we can determine the volume of the region [see Problem 5(a)], and then differentiate with respect to r to find the maximum. We see that

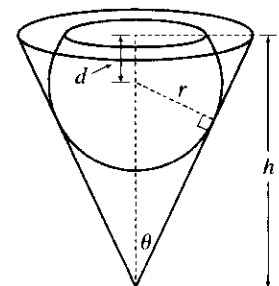

$$\sin \theta = \frac{r}{h - d} \Leftrightarrow h - d = \frac{r}{\sin \theta} \Leftrightarrow d = h - r \csc \theta.$$

Now we can use the formula from Problem 5(a) to find the volume of water displaced:

$$\begin{aligned} V &= \frac{1}{3}\pi h^2(3r - h) = \frac{1}{3}\pi(r + d)^2 [3r - (r + d)] = \frac{1}{3}\pi(r + h - r \csc \theta)^2(2r - h + r \csc \theta) \\ &= \frac{\pi}{3}[r(1 - \csc \theta) + h]^2[r(2 + \csc \theta) - h] \end{aligned}$$

Now we differentiate with respect to r :

$$\begin{aligned} dV/dr &= \frac{\pi}{3} \{ [r(1 - \csc \theta) + h]^2(2 + \csc \theta) + 2[r(1 - \csc \theta) + h](1 - \csc \theta)[r(2 + \csc \theta) - h] \} \\ &= \frac{\pi}{3} [r(1 - \csc \theta) + h] \{ [r(1 - \csc \theta) + h](2 + \csc \theta) + 2(1 - \csc \theta)[r(2 + \csc \theta) - h] \} \\ &= \frac{\pi}{3} [r(1 - \csc \theta) + h] \{ 3(2 + \csc \theta)(1 - \csc \theta)r + [(2 + \csc \theta) - 2(1 - \csc \theta)]h \} \\ &= \frac{\pi}{3} [r(1 - \csc \theta) + h] \{ 3(2 + \csc \theta)(1 - \csc \theta)r + 3h \csc \theta \} \end{aligned}$$

This is 0 when $r = \frac{h}{\csc \theta - 1}$ and when $r = \frac{h \csc \theta}{(\csc \theta + 2)(\csc \theta - 1)}$. Now since $V\left(\frac{h}{\csc \theta - 1}\right) = 0$

(the first factor vanishes; this corresponds to $d = -r$), the maximum volume of water is displaced when

$r = \frac{h \csc \theta}{(\csc \theta - 1)(\csc \theta + 2)}$. (Our intuition tells us that a maximum value does exist, and it must occur at a critical

number.) Multiplying numerator and denominator by $\sin^2 \theta$, we get an alternative form of the answer:

$$r = \frac{h \sin \theta}{\sin \theta + \cos 2\theta}.$$

11. (a) Stacking disks along the y -axis gives us $V = \int_0^h \pi [f(y)]^2 dy$.

(b) Using the Chain Rule, $\frac{dV}{dt} = \frac{dV}{dh} \cdot \frac{dh}{dt} = \pi [f(h)]^2 \frac{dh}{dt}$.

(c) $kA \sqrt{h} = \pi [f(h)]^2 \frac{dh}{dt}$. Set $\frac{dh}{dt} = C$: $\pi [f(h)]^2 C = kA \sqrt{h} \Rightarrow [f(h)]^2 = \frac{kA}{\pi C} \sqrt{h} \Rightarrow$

$f(h) = \sqrt{\frac{kA}{\pi C}} h^{1/4}$; that is, $f(y) = \sqrt{\frac{kA}{\pi C}} y^{1/4}$. The advantage of having $\frac{dh}{dt} = C$ is that the markings on the container are equally spaced.

12. (a) We first use the cylindrical shell method to express the volume V in terms of h , r , and ω :

$$\begin{aligned} V &= \int_0^r 2\pi xy dx = \int_0^r 2\pi x \left[h + \frac{\omega^2 x^2}{2g} \right] dx = 2\pi \int_0^r \left(hx + \frac{\omega^2 x^3}{2g} \right) dx \\ &= 2\pi \left[\frac{hx^2}{2} + \frac{\omega^2 x^4}{8g} \right]_0^r = 2\pi \left[\frac{hr^2}{2} + \frac{\omega^2 r^4}{8g} \right] = \pi hr^2 + \frac{\pi \omega^2 r^4}{4g} \Rightarrow \end{aligned}$$

$$h = \frac{V - (\pi \omega^2 r^4)/(4g)}{\pi r^2} = \frac{4gV - \pi \omega^2 r^4}{4\pi g r^2}.$$

(b) The surface touches the bottom when $h = 0 \Rightarrow 4gV - \pi\omega^2 r^4 = 0 \Rightarrow \omega^2 = \frac{4gV}{\pi r^4} \Rightarrow \omega = \frac{2\sqrt{gV}}{\sqrt{\pi r^2}}$.

To spill over the top, $y(r) > L \Leftrightarrow$

$$L < h + \frac{\omega^2 r^2}{2g} = \frac{4gV - \pi\omega^2 r^4}{4\pi g r^2} + \frac{\omega^2 r^2}{2g} = \frac{4gV}{4\pi g r^2} - \frac{\pi\omega^2 r^2}{4\pi g r^2} + \frac{\omega^2 r^2}{2g}$$

$$= \frac{V}{\pi r^2} - \frac{\omega^2 r^2}{4g} + \frac{\omega^2 r^2}{2g} = \frac{V}{\pi r^2} + \frac{\omega^2 r^2}{4g} \Leftrightarrow$$

$\frac{\omega^2 r^2}{4g} > L - \frac{V}{\pi r^2} = \frac{\pi r^2 L - V}{\pi r^2} \Leftrightarrow \omega^2 > \frac{4g(\pi r^2 L - V)}{\pi r^4}$. So for spillage, the angular speed should

be $\omega > \frac{2\sqrt{g(\pi r^2 L - V)}}{r^2 \sqrt{\pi}}$.

(c) (i) Here we have $r = 2, L = 7, h = 7 - 5 = 2$. When $x = 1, y = 7 - 4 = 3$. Therefore, $3 = 2 + \frac{\omega^2 \cdot 1^2}{2 \cdot 32}$
 $\Rightarrow 1 = \frac{\omega^2}{2 \cdot 32} \Rightarrow \omega^2 = 64 \Rightarrow \omega = 8 \text{ rad/s}$. $V = \pi(2)(2)^2 + \frac{\pi \cdot 8^2 \cdot 2^4}{4g} = 8\pi + 8\pi = 16\pi \text{ ft}^3$.

(ii) At the wall, $x = 2$, so $y = 2 + \frac{8^2 \cdot 2^2}{2 \cdot 32} = 6$ and the surface is $7 - 6 = 1 \text{ ft}$ below the top of the tank.

13. We assume that P lies in the region of positive x . Since $y = x^3$ is an odd

function, this assumption will not affect the result of the calculation. Let

$P = (a, a^3)$. The slope of the tangent to the curve $y = x^3$ at P is $3a^2$, and so

the equation of the tangent is $y - a^3 = 3a^2(x - a) \Leftrightarrow y = 3a^2x - 2a^3$.

We solve this simultaneously with $y = x^3$ to find the other point of intersection:

$x^3 = 3a^2x - 2a^3 \Leftrightarrow (x - a)^2(x + 2a) = 0$. So $Q = (-2a, -8a^3)$ is

the other point of intersection. The equation of the tangent at Q is

$y - (-8a^3) = 12a^2[x - (-2a)] \Leftrightarrow y = 12a^2x + 16a^3$. By symmetry,

this tangent will intersect the curve again at $x = -2(-2a) = 4a$. The curve lies above the first tangent, and below

the second, so we are looking for a relationship between $A = \int_{-2a}^a [x^3 - (3a^2x - 2a^3)] dx$ and

$B = \int_{-2a}^{4a} [(12a^2x + 16a^3) - x^3] dx$. We calculate $A = [\frac{1}{4}x^4 - \frac{3}{2}a^2x^2 + 2a^3x]_{-2a}^a = \frac{3}{4}a^4 - (-6a^4) = \frac{27}{4}a^4$,

and $B = [6a^2x^2 + 16a^3x - \frac{1}{4}x^4]_{-2a}^{4a} = 96a^4 - (-12a^4) = 108a^4$. We see that $B = 16A = 2^4A$. This is

because our calculation of area B was essentially the same as that of area A , with a replaced by $-2a$, so if we

replace a with $-2a$ in our expression for A , we get $\frac{27}{4}(-2a)^4 = 108a^4 = B$.

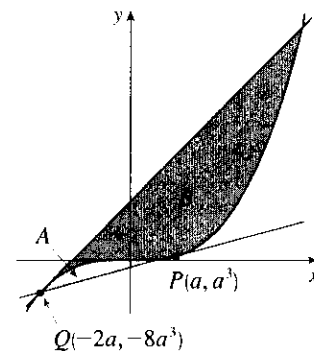

14. (a) Place the round flat tortilla on an xy -coordinate system as

shown in the first figure. An equation of the circle is

$x^2 + y^2 = 4^2$ and the height of a cross-section is

$2\sqrt{16 - x^2}$.

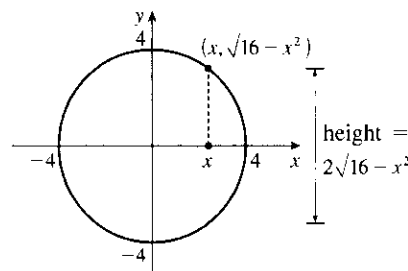

Now look at a cross-section with central angle θ_x as shown in the second figure (r is the radius of the circular cylinder).

The filled area $A(x)$ is equal to the area $A_1(x)$ of the sector minus the area $A_2(x)$ of the triangle.

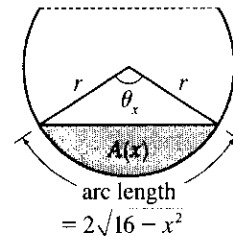

$$\begin{aligned}
 A(x) &= A_1(x) - A_2(x) \\
 &= \frac{1}{2}r^2\theta_x - \frac{1}{2}r^2 \sin \theta_x \quad [\text{area formulas from trigonometry}] \\
 &= \frac{1}{2}r(r\theta_x) - \frac{1}{2}r^2 \sin\left(\frac{s}{r}\right) \quad [\text{arc length } s = r\theta_x \Rightarrow \theta_x = s/r] \\
 &= \frac{1}{2}r \cdot 2\sqrt{16-x^2} - \frac{1}{2}r^2 \sin\left(\frac{2\sqrt{16-x^2}}{r}\right) \quad [s = 2\sqrt{16-x^2}] \\
 &= r\sqrt{16-x^2} - \frac{1}{2}r^2 \sin\left(\frac{2}{r}\sqrt{16-x^2}\right) \quad (*)
 \end{aligned}$$

Note that the central angle θ_x will be small near the ends of the tortilla; that is, when $|x| \approx 4$. But near the center of the tortilla (when $|x| \approx 0$), the central angle θ_x may exceed 180° . Thus, the sine of θ_x will be negative and the second term in (*) will be positive (actually adding area to the area of the sector). The volume of the taco can be found by integrating the cross-sectional areas from $x = -4$ to $x = 4$. Thus,

$$V(x) = \int_{-4}^4 A(x) dx = \int_{-4}^4 \left[r\sqrt{16-x^2} - \frac{1}{2}r^2 \sin\left(\frac{2}{r}\sqrt{16-x^2}\right) \right] dx$$

(b) To find the value of r that maximizes the volume of the taco, we can define the function

$$V(r) = \int_{-4}^4 \left[r\sqrt{16-x^2} - \frac{1}{2}r^2 \sin\left(\frac{2}{r}\sqrt{16-x^2}\right) \right] dx$$

The third figure shows a graph of $y = V(r)$ and $y = V'(r)$. The maximum volume of about 52.94 occurs when $r \approx 2.2912$.

