

# Chapter 11

*Adapted from the*  
**Complete Solutions Manual**

*for*  
**James Stewart's**  
**Calculus – 5<sup>th</sup> Edition**

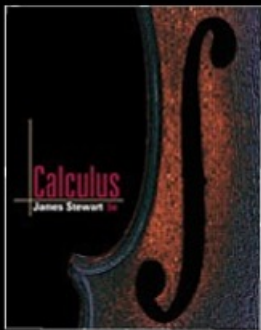

Calculus 5e  
James Stewart  
ISBN 0-534-39339-X

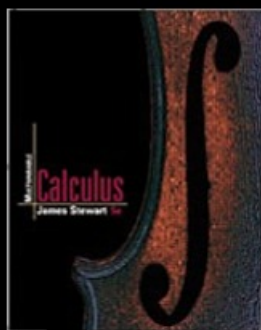

Calculus 5e - Multivariable  
James Stewart  
ISBN 0-534-39357-8

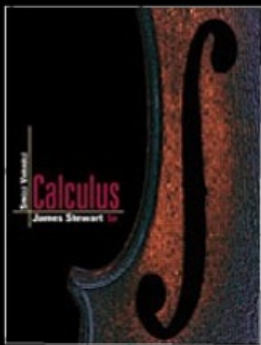

Calculus 5e - Single Variable  
James Stewart  
ISBN 0-534-39366-7

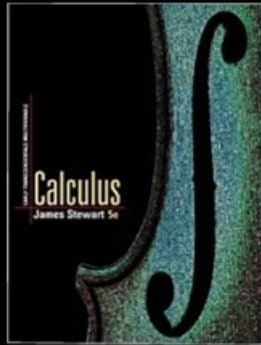

Calculus 5e - Multivariable  
Early Transcendentals  
James Stewart  
ISBN 0-534-41778-7

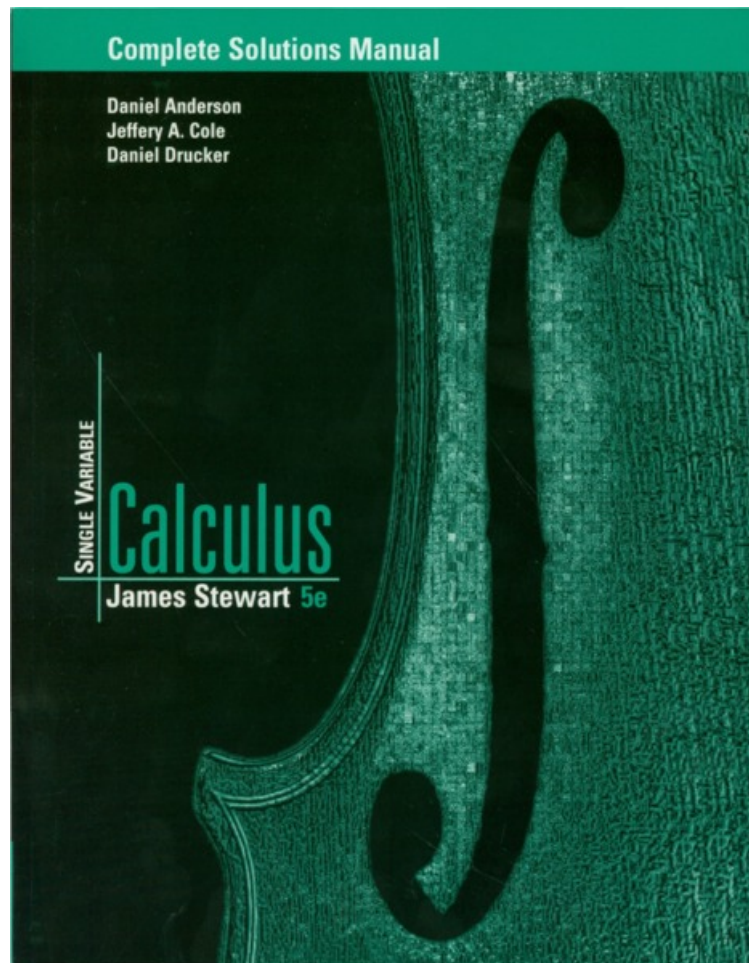

# 11 □ PARAMETRIC EQUATIONS AND POLAR COORDINATES

## 11.1 Curves Defined by Parametric Equations

1.  $x = 1 + \sqrt{t}$ ,  $y = t^2 - 4t$ ,  $0 \leq t \leq 5$

$t$	0	1	2	3	4	5
$x$	1	2	$1 + \sqrt{2}$	$1 + \sqrt{3}$	3	$1 + \sqrt{5}$
			2.41	2.73		3.24
$y$	0	-3	-4	-3	0	5

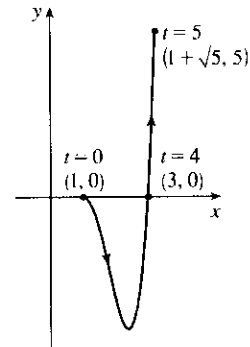

2.  $x = 2 \cos t$ ,  $y = t - \cos t$ ,  $0 \leq t \leq 2\pi$

$t$	0	$\pi/2$	$\pi$	$3\pi/2$	$2\pi$
$x$	2	0	-2	0	2
$y$	-1	$\pi/2$	$\pi + 1$	$3\pi/2$	$2\pi - 1$
		1.57	4.14	4.71	5.28

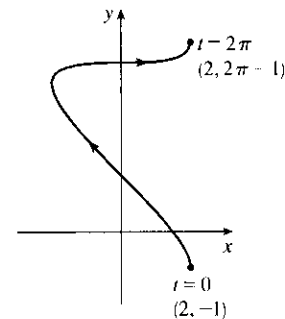

3.  $x = 5 \sin t$ ,  $y = t^2$ ,  $-\pi \leq t \leq \pi$

$t$	$-\pi$	$-\pi/2$	0	$\pi/2$	$\pi$
$x$	0	-5	0	5	0
$y$	$\pi^2$	$\pi^2/4$	0	$\pi^2/4$	$\pi^2$
	9.87	2.47		2.47	9.87

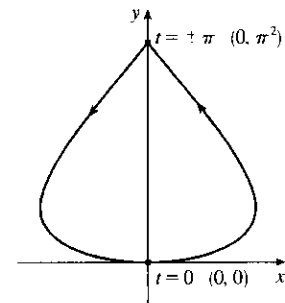

4.  $x = e^{-t} + t$ ,  $y = e^t - t$ ,  $-2 \leq t \leq 2$

$t$	-2	-1	0	1	2
$x$	$e^2 - 2$	$e - 1$	1	$e^{-1} + 1$	$e^{-2} + 2$
	5.39	1.72		1.37	2.14
$y$	$e^{-2} + 2$	$e^{-1} + 1$	1	$e - 1$	$e^2 - 2$
	2.14	1.37		1.72	5.39

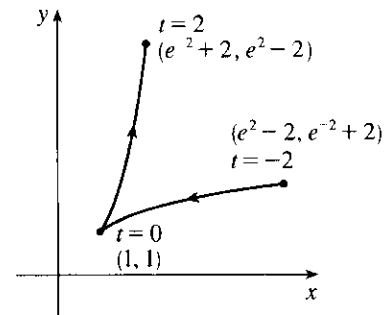

5.  $x = 3t - 5, y = 2t + 1$

(a)	$t$	-2	-1	0	1	2	3	4
	$x$	-11	-8	-5	-2	1	4	7
	$y$	-3	-1	1	3	5	7	9

(b)  $x = 3t - 5 \Rightarrow 3t = x + 5 \Rightarrow t = \frac{1}{3}(x + 5) \Rightarrow$   
 $y = 2 \cdot \frac{1}{3}(x + 5) + 1, \text{ so } y = \frac{2}{3}x + \frac{13}{3}.$

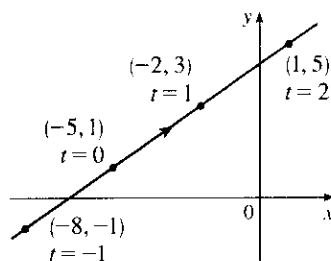

6.  $x = 1 + t, y = 5 - 2t, -2 \leq t \leq 3$

(a)	$t$	-2	-1	0	1	2	3
	$x$	-1	0	1	2	3	4
	$y$	9	7	5	3	1	-1

(b)  $x = 1 + t \Rightarrow t = x - 1 \Rightarrow y = 5 - 2(x - 1),$   
 so  $y = -2x + 7, -1 \leq x \leq 4.$

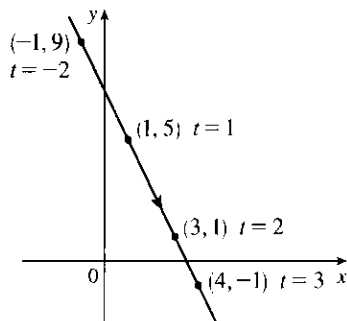

7.  $x = t^2 - 2, y = 5 - 2t, -3 \leq t \leq 4$

(a)	$t$	-3	-2	-1	0	1	2	3	4
	$x$	7	2	-1	-2	-1	2	7	14
	$y$	11	9	7	5	3	1	-1	-3

(b)  $y = 5 - 2t \Rightarrow 2t = 5 - y \Rightarrow t = \frac{1}{2}(5 - y) \Rightarrow$   
 $x = \left[\frac{1}{2}(5 - y)\right]^2 - 2, \text{ so } x = \frac{1}{4}(5 - y)^2 - 2,$   
 $-3 \leq y \leq 11.$

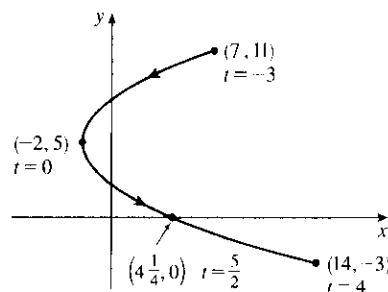

8.  $x = 1 + 3t, y = 2 - t^2$

(a)	$t$	-3	-2	-1	0	1	2	3
	$x$	-8	-5	-2	1	4	7	10
	$y$	-7	-2	1	2	1	-2	-7

(b)  $x = 1 + 3t \Rightarrow t = \frac{1}{3}(x - 1) \Rightarrow$   
 $y = 2 - \left[\frac{1}{3}(x - 1)\right]^2, \text{ so } y = -\frac{1}{9}(x - 1)^2 + 2.$

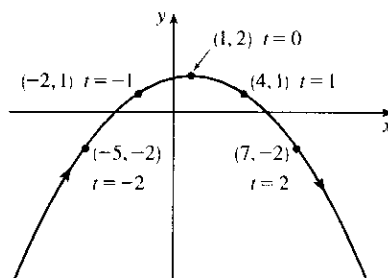

9. (a)  $x = \sqrt{t}, y = 1 - t$

$t$	0	1	2	3	4
$x$	0	1	1.414	1.732	2
$y$	1	0	-1	-2	-3

(b)  $x = \sqrt{t} \Rightarrow t = x^2 \Rightarrow y = 1 - t = 1 - x^2.$   
 Since  $t \geq 0, x \geq 0.$

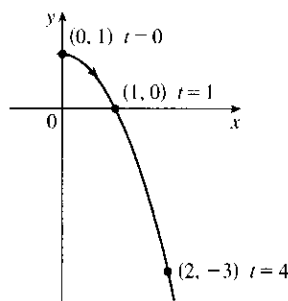

10. (a)  $x = t^2, y = t^3$

$t$	-2	-1	0	1	2
$x$	4	1	0	1	4
$y$	-8	-1	0	1	8

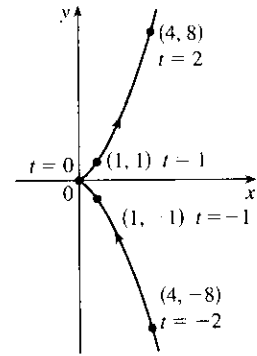

(b)  $y = t^3 \Rightarrow t = \sqrt[3]{y} \Rightarrow x = t^2 = (\sqrt[3]{y})^2 = y^{2/3}$ .  
 $t \in \mathbb{R}, y \in \mathbb{R}, x \geq 0$ .

11. (a)  $x = \sin \theta, y = \cos \theta, 0 \leq \theta \leq \pi$ .

$x^2 + y^2 = \sin^2 \theta + \cos^2 \theta = 1$ . Since  
 $0 \leq \theta \leq \pi$ , we have  $\sin \theta \geq 0$ , so  $x \geq 0$ .

12. (a)  $x = 4 \cos \theta, y = 5 \sin \theta, -\pi/2 \leq \theta \leq \pi/2$ .

$(\frac{x}{4})^2 + (\frac{y}{5})^2 = \cos^2 \theta + \sin^2 \theta = 1$ , which is an ellipse with  $x$ -intercepts  $(\pm 4, 0)$  and  $y$ -intercepts  $(0, \pm 5)$ . We obtain the portion of the ellipse with  $x \geq 0$  since  $4 \cos \theta \geq 0$  for  $-\pi/2 \leq \theta \leq \pi/2$ .

(b)

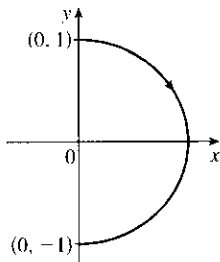

(b)

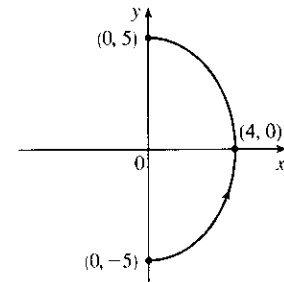

13. (a)  $x = \sin^2 \theta, y = \cos^2 \theta$ .

$x + y = \sin^2 \theta + \cos^2 \theta = 1, 0 \leq x \leq 1$ .

Note that the curve is at  $(0, 1)$  whenever  $\theta = \pi n$  and is at  $(1, 0)$  whenever  $\theta = \frac{\pi}{2}n$  for every integer  $n$ .

14. (a)  $x = \sec \theta, y = \tan \theta, -\frac{\pi}{2} < \theta < \frac{\pi}{2}$ .

$x^2 - y^2 = \sec^2 \theta - \tan^2 \theta = 1, x \geq 1$ ,  
 or  $x = \sqrt{y^2 + 1}$ .

(b)

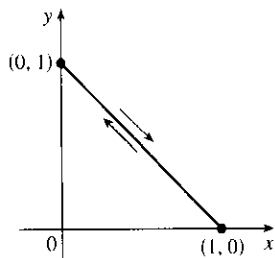

(b)

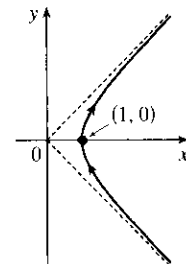

15. (a)  $x = e^t, y = e^{-t}$   
 $y = 1/e^t = 1/x, x > 0$

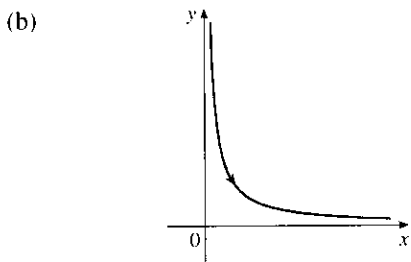

16. (a)  $x = \ln t, y = \sqrt{t}, t \geq 1$   
 $x = \ln t \Rightarrow t = e^x \Rightarrow$   
 $y = \sqrt{t} = e^{x/2}, x \geq 0$

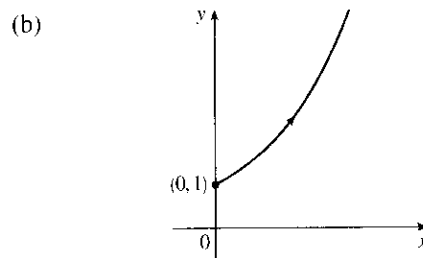

17. (a)  $x = \cosh t, y = \sinh t$   
 $x^2 - y^2 = \cosh^2 t - \sinh^2 t = 1, x \geq 1$

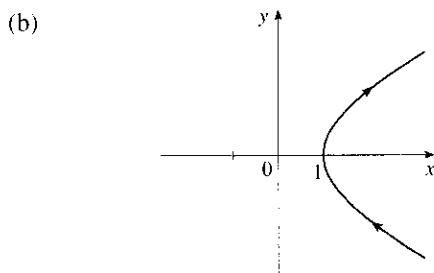

18. (a)  $x = 1 + \cos \theta \Rightarrow \cos \theta = x - 1$   
 $y = 2 \cos \theta - 1 = 2(x - 1) - 1 = 2x - 3,$   
 $0 \leq x \leq 2.$

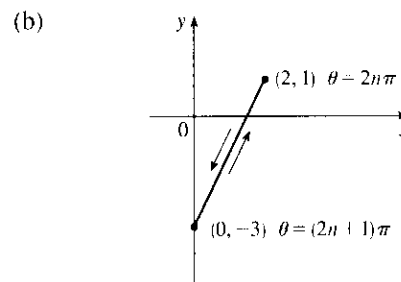

19.  $x^2 + y^2 = \cos^2 \pi t + \sin^2 \pi t = 1, 1 \leq t \leq 2$ , so the particle moves counterclockwise along the circle  $x^2 + y^2 = 1$  from  $(-1, 0)$  to  $(1, 0)$ , along the lower half of the circle.

20.  $(x - 2)^2 + (y - 3)^2 = \cos^2 t + \sin^2 t = 1$ , so the motion takes place on a unit circle centered at  $(2, 3)$ . As  $t$  goes from  $0$  to  $2\pi$ , the particle makes one complete counterclockwise rotation around the circle, starting and ending at  $(3, 3)$ .

21.  $(\frac{1}{2}x)^2 + (\frac{1}{3}y)^2 = \sin^2 t + \cos^2 t = 1$ , so the particle moves once clockwise along the ellipse  $\frac{1}{4}x^2 + \frac{1}{9}y^2 = 1$ , starting and ending at  $(0, 3)$ .

22.  $x = \cos^2 t = y^2$ , so the particle moves along the parabola  $x = y^2$ . As  $t$  goes from  $0$  to  $4\pi$ , the particle moves from  $(1, 1)$  down to  $(1, -1)$  (at  $t = \pi$ ), back up to  $(1, 1)$  again (at  $t = 2\pi$ ), and then repeats this entire cycle between  $t = 2\pi$  and  $t = 4\pi$ .

23. We must have  $1 \leq x \leq 4$  and  $2 \leq y \leq 3$ . So the graph of the curve must be contained in the rectangle  $[1, 4]$  by  $[2, 3]$ .

24. (a) From the first graph, we have  $1 \leq x \leq 2$ . From the second graph, we have  $-1 \leq y \leq 1$ . The only choice that satisfies either of those conditions is III.

(b) From the first graph, the values of  $x$  cycle through the values from  $-2$  to  $2$  four times. From the second graph, the values of  $y$  cycle through the values from  $-2$  to  $2$  six times. Choice I satisfies these conditions.

(c) From the first graph, the values of  $x$  cycle through the values from  $-2$  to  $2$  three times. From the second graph, we have  $0 \leq y \leq 2$ . Choice IV satisfies these conditions.

(d) From the first graph, the values of  $x$  cycle through the values from  $-2$  to  $2$  two times. From the second graph, the values of  $y$  do the same thing. Choice II satisfies these conditions.

25. When  $t = -1$ ,  $(x, y) = (0, -1)$ . As  $t$  increases to 0,  $x$  decreases to  $-1$  and  $y$  increases to 0. As  $t$  increases from 0 to 1,  $x$  increases to 0 and  $y$  increases to 1. As  $t$  increases beyond 1, both  $x$  and  $y$  increase. For  $t < -1$ ,  $x$  is positive and decreasing and  $y$  is negative and increasing. We could achieve greater accuracy by estimating  $x$ - and  $y$ -values for selected values of  $t$  from the given graphs and plotting the corresponding points.

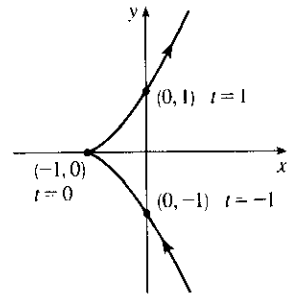

26. For  $t < -1$ ,  $x$  is positive and decreasing, while  $y$  is negative and increasing (these points are in Quadrant IV). When  $t = -1$ ,  $(x, y) = (0, 0)$  and, as  $t$  increases from  $-1$  to 0,  $x$  becomes negative and  $y$  increases from 0 to 1. At  $t = 0$ ,  $(x, y) = (0, 1)$  and, as  $t$  increases from 0 to 1,  $y$  decreases from 1 to 0 and  $x$  is positive. At  $t = 1$ ,  $(x, y) = (0, 0)$  again, so the loop is completed. For  $t > 1$ ,  $x$  and  $y$  both become large negative. This enables us to draw a rough sketch. We could achieve greater accuracy by estimating  $x$ - and  $y$ -values for selected values of  $t$  from the given graphs and plotting the corresponding points.

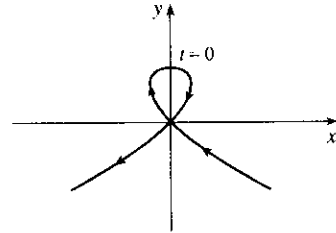

27. When  $t = 0$  we see that  $x = 0$  and  $y = 0$ , so the curve starts at the origin. As  $t$  increases from 0 to  $\frac{1}{2}$ , the graphs show that  $y$  increases from 0 to 1 while  $x$  increases from 0 to 1, decreases to 0 and to  $-1$ , then increases back to 0, so we arrive at the point  $(0, 1)$ . Similarly, as  $t$  increases from  $\frac{1}{2}$  to 1,  $y$  decreases from 1 to 0 while  $x$  repeats its pattern, and we arrive back at the origin. We could achieve greater accuracy by estimating  $x$ - and  $y$ -values for selected values of  $t$  from the given graphs and plotting the corresponding points.

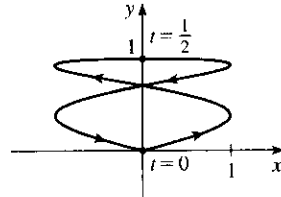

28. (a) Note that as  $t \rightarrow -\infty$ , we have  $x \rightarrow -\infty$  and  $y \rightarrow \infty$ , whereas when  $t \rightarrow \infty$ , both  $x$  and  $y \rightarrow \infty$ . This description fits only IV. [But also note that  $x(t)$  increases, then decreases, then increases again.]
- (b) Note that as  $t \rightarrow \pm\infty$ ,  $y \rightarrow -\infty$ . This is only the case with VI.
- (c) If  $t = 0$ , then  $(x, y) = (\sin 0, \sin 0) = (0, 0)$ . Also,  $|x| = |\sin 3t| \leq 1$  for all  $t$ , and  $|y| = |\sin 4t| \leq 1$  for all  $t$ . The only graph which includes the point  $(0, 0)$  and which has  $|x| \leq 1$  and  $|y| \leq 1$ , is V.
- (d) Note that as  $t \rightarrow -\infty$ , both  $x$  and  $y \rightarrow -\infty$ , and as  $t \rightarrow \infty$ , both  $x$  and  $y \rightarrow \infty$ . This description fits only III. (Also note that, since  $\sin 2t$  and  $\sin 3t$  lie between  $-1$  and  $1$ , the curve never strays very far from the line  $y = x$ .)
- (e) Note that both  $x(t)$  and  $y(t)$  are periodic with period  $2\pi$  and satisfy  $|x| \leq 1$  and  $|y| \leq 1$ . Now the only  $y$ -intercepts occur when  $x = \sin(t + \sin t) = 0 \Leftrightarrow t = 0$  or  $\pi$ . So there should be two  $y$ -intercepts:  $y(0) = \cos 1 \approx 0.54$  and  $y(\pi) = \cos(\pi - 1) \approx -0.54$ . Similarly, there should be two  $x$ -intercepts:  $x(\frac{\pi}{2}) = \sin(\frac{\pi}{2} + 1) \approx 0.54$  and  $x(\frac{3\pi}{2}) = \sin(\frac{3\pi}{2} - 1) \approx -0.54$ . The only curve with these  $x$ - and  $y$ -intercepts is I.
- (f) Note that  $x(t)$  is periodic with period  $2\pi$ , so the only  $y$ -intercepts occur when  $x = \cos t = 0 \Leftrightarrow t = \frac{\pi}{2}$  or  $\frac{3\pi}{2}$ . Also, the graph is symmetric about the  $x$ -axis, since  $y(-t) = \sin(-t + \sin 5(-t)) = \sin(-t - \sin 5t) = -\sin(t + \sin 5t) = -y(t)$ , and  $x(-t) = \cos(-t) = \cos t = x(t)$ . The only graph which has only two  $y$ -intercepts, and is symmetric about the  $x$ -axis, is II.

29. As in Example 5, we let  $y = t$  and  $x = t - 3t^3 + t^5$  and use a  $t$ -interval of  $[-2\pi, 2\pi]$ .

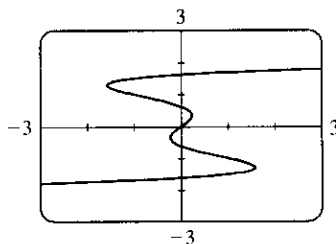

30. We use  $x_1 = t, y_1 = t^5$  and  $x_2 = t(t-1)^2, y_2 = t$  with  $-2\pi \leq t \leq 2\pi$ . There are 3 points of intersection;  $(0, 0)$  is fairly obvious. The point in quadrant III is approximately  $(-0.8, -0.4)$  and the point in quadrant I is approximately  $(1.1, 1.8)$ .

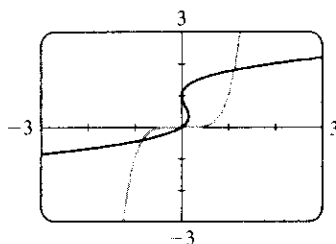

31. (a)  $x = x_1 + (x_2 - x_1)t, y = y_1 + (y_2 - y_1)t, 0 \leq t \leq 1$ . Clearly the curve passes through  $P_1(x_1, y_1)$  when  $t = 0$  and through  $P_2(x_2, y_2)$  when  $t = 1$ . For  $0 < t < 1$ ,  $x$  is strictly between  $x_1$  and  $x_2$  and  $y$  is strictly between  $y_1$  and  $y_2$ . For every value of  $t$ ,  $x$  and  $y$  satisfy the relation  $y - y_1 = \frac{y_2 - y_1}{x_2 - x_1}(x - x_1)$ , which is the equation of the line through  $P_1(x_1, y_1)$  and  $P_2(x_2, y_2)$ .

Finally, any point  $(x, y)$  on that line satisfies  $\frac{y - y_1}{y_2 - y_1} = \frac{x - x_1}{x_2 - x_1}$ ; if we call that common value  $t$ , then the given parametric equations yield the point  $(x, y)$ ; and any  $(x, y)$  on the line between  $P_1(x_1, y_1)$  and  $P_2(x_2, y_2)$  yields a value of  $t$  in  $[0, 1]$ . So the given parametric equations exactly specify the line segment from  $P_1(x_1, y_1)$  to  $P_2(x_2, y_2)$ .

(b)  $x = -2 + [3 - (-2)]t = -2 + 5t$  and  $y = 7 + (-1 - 7)t = 7 - 8t$  for  $0 \leq t \leq 1$ .

32. For the side of the triangle from  $A$  to  $B$ , use  $(x_1, y_1) = (1, 1)$  and  $(x_2, y_2) = (4, 2)$ . Hence, the equations are  $x = x_1 + (x_2 - x_1)t = 1 + (4 - 1)t = 1 + 3t, y = y_1 + (y_2 - y_1)t = 1 + (2 - 1)t = 1 + t$ . Graphing  $x = 1 + 3t$  and  $y = 1 + t$  with  $0 \leq t \leq 1$  gives us the side of the triangle from  $A$  to  $B$ . Similarly, for the side  $BC$  we use  $x = 4 - 3t$  and  $y = 2 + 3t$ , and for the side  $AC$  we use  $x = 1$  and  $y = 1 + 4t$ .

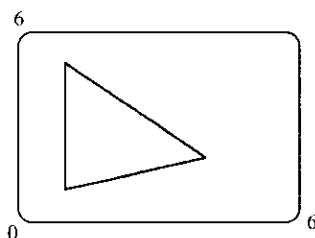

33. The circle  $x^2 + y^2 = 4$  can be represented parametrically by  $x = 2 \cos t, y = 2 \sin t; 0 \leq t \leq 2\pi$ . The circle  $x^2 + (y - 1)^2 = 4$  can be represented by  $x = 2 \cos t, y = 1 + 2 \sin t; 0 \leq t \leq 2\pi$ . This representation gives us the circle with a counterclockwise orientation starting at  $(2, 1)$ .

(a) To get a clockwise orientation, we could change the equations to  $x = 2 \cos t, y = 1 - 2 \sin t, 0 \leq t \leq 2\pi$ .

(b) To get three times around in the counterclockwise direction, we use the original equations  $x = 2 \cos t, y = 1 + 2 \sin t$  with the domain expanded to  $0 \leq t \leq 6\pi$ .

(c) To start at  $(0, 3)$  using the original equations, we must have  $x_1 = 0$ ; that is,  $2 \cos t = 0$ . Hence,  $t = \frac{\pi}{2}$ . So we use  $x = 2 \cos t, y = 1 + 2 \sin t; \frac{\pi}{2} \leq t \leq \frac{3\pi}{2}$ .

Alternatively, if we want  $t$  to start at 0, we could change the equations of the curve. For example, we could use  $x = -2 \sin t, y = 1 + 2 \cos t, 0 \leq t \leq \pi$ .

34.

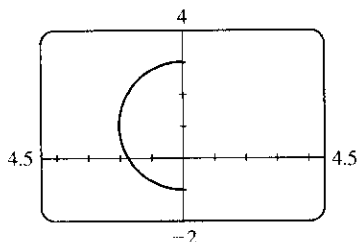

35. (a) Let  $x^2/a^2 = \sin^2 t$  and  $y^2/b^2 = \cos^2 t$  to obtain  $x = a \sin t$  and  $y = b \cos t$  with  $0 \leq t \leq 2\pi$  as possible parametric equations for the ellipse  $x^2/a^2 + y^2/b^2 = 1$ .

(b) The equations are  $x = 3 \sin t$  and  $y = b \cos t$  for  $b \in \{1, 2, 4, 8\}$ .

(c) As  $b$  increases, the ellipse stretches vertically.

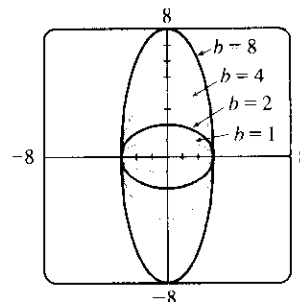

36. The possible parametrizations of the curve  $y = x^3$  include

- (1)  $x = t, y = t^3, t \in \mathbb{R}$
- (2)  $x = -t, y = -t^3, t \in \mathbb{R}$
- (3)  $x = t + 1, y = (t + 1)^3, t \in \mathbb{R}$

37. The case  $\frac{\pi}{2} < \theta < \pi$  is illustrated.  $C$  has coordinates  $(r\theta, r)$  as in Example 6, and  $Q$  has coordinates  $(r\theta, r + r \cos(\pi - \theta)) = (r\theta, r(1 - \cos \theta))$  [since  $\cos(\pi - \alpha) = \cos \pi \cos \alpha + \sin \pi \sin \alpha = -\cos \alpha$ ], so  $P$  has coordinates  $(r\theta - r \sin(\pi - \theta), r(1 - \cos \theta)) = (r(\theta - \sin \theta), r(1 - \cos \theta))$  [since  $\sin(\pi - \alpha) = \sin \pi \cos \alpha - \cos \pi \sin \alpha = \sin \alpha$ ]. Again we have the parametric equations  $x = r(\theta - \sin \theta), y = r(1 - \cos \theta)$ .

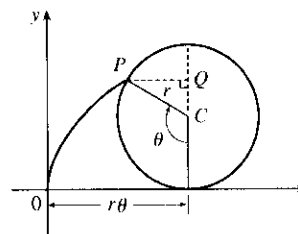



38. The first two diagrams depict the case  $\pi < \theta < \frac{3\pi}{2}$ ,  $d < r$ . As in Example 6,  $C$  has coordinates  $(r\theta, r)$ .

Now  $Q$  (in the second diagram) has coordinates  $(r\theta, r + d \cos(\theta - \pi)) = (r\theta, r - d \cos \theta)$ , so a typical point  $P$  of the trochoid has coordinates  $(r\theta + d \sin(\theta - \pi), r - d \cos \theta)$ . That is,  $P$  has coordinates  $(x, y)$ , where  $x = r\theta - d \sin \theta$  and  $y = r - d \cos \theta$ . When  $d = r$ , these equations agree with those of the cycloid.

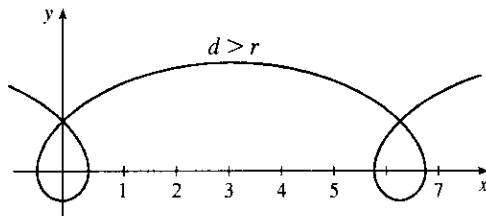
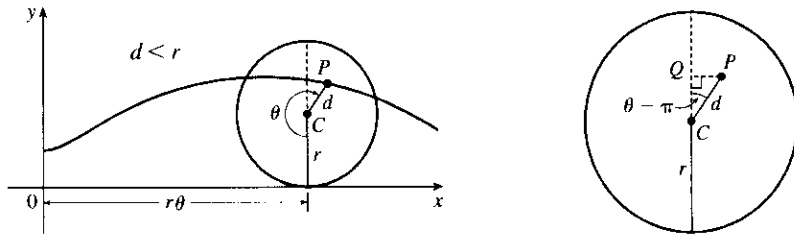

39. It is apparent that  $x = |OQ|$  and  $y = |QP| = |ST|$ . From the diagram,  $x = |OQ| = a \cos \theta$  and  $y = |ST| = b \sin \theta$ . Thus, the parametric equations are  $x = a \cos \theta$  and  $y = b \sin \theta$ . To eliminate  $\theta$  we rearrange:  $\sin \theta = y/b \Rightarrow \sin^2 \theta = (y/b)^2$  and  $\cos \theta = x/a \Rightarrow \cos^2 \theta = (x/a)^2$ . Adding the two equations:  $\sin^2 \theta + \cos^2 \theta = 1 = x^2/a^2 + y^2/b^2$ . Thus, we have an ellipse.

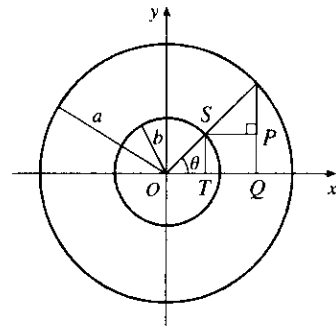

40.  $A$  has coordinates  $(a \cos \theta, a \sin \theta)$ . Since  $OA$  is perpendicular to  $AB$ ,  $\triangle OAB$  is a right triangle and  $B$  has coordinates  $(a \sec \theta, 0)$ . It follows that  $P$  has coordinates  $(a \sec \theta, b \sin \theta)$ . Thus, the parametric equations are  $x = a \sec \theta, y = b \sin \theta$ .

41.  $C = (2a \cot \theta, 2a)$ , so the  $x$ -coordinate of  $P$  is  $x = 2a \cot \theta$ . Let  $B = (0, 2a)$ . Then  $\angle OAB$  is a right angle and  $\angle OBA = \theta$ , so  $|OA| = 2a \sin \theta$  and  $A = ((2a \sin \theta) \cos \theta, (2a \sin \theta) \sin \theta)$ . Thus, the  $y$ -coordinate of  $P$  is  $y = 2a \sin^2 \theta$ .

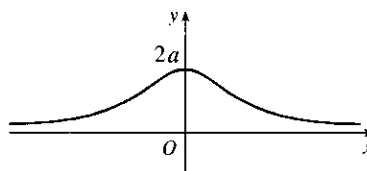

42. Let  $\theta$  be the angle of inclination of segment  $OP$ . Then

$$|OB| = \frac{2a}{\cos \theta}. \text{ Let } C = (2a, 0). \text{ Then by use of right triangle}$$

$OAC$  we see that  $|OA| = 2a \cos \theta$ . Now

$$\begin{aligned} |OP| &= |AB| = |OB| - |OA| = 2a \left( \frac{1}{\cos \theta} - \cos \theta \right) \\ &= 2a \frac{1 - \cos^2 \theta}{\cos \theta} = 2a \frac{\sin^2 \theta}{\cos \theta} = 2a \sin \theta \tan \theta \end{aligned}$$

So  $P$  has coordinates  $x = 2a \sin \theta \tan \theta \cdot \cos \theta = 2a \sin^2 \theta$  and

$$y = 2a \sin \theta \tan \theta \cdot \sin \theta = 2a \sin^2 \theta \tan \theta.$$

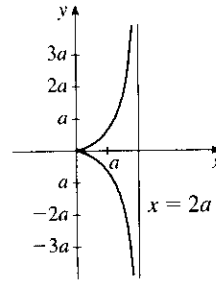

43. (a)

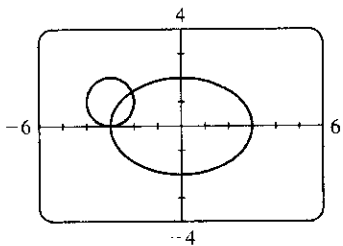

There are 2 points of intersection:

$(-3, 0)$  and approximately  $(-2.1, 1.4)$ .

(b) A collision point occurs when  $x_1 = x_2$  and  $y_1 = y_2$  for the same  $t$ . So solve the equations:

$$3 \sin t = -3 + \cos t \quad (1)$$

$$2 \cos t = 1 + \sin t \quad (2)$$

From (2),  $\sin t = 2 \cos t - 1$ . Substituting into (1), we get  $3(2 \cos t - 1) = -3 + \cos t \Rightarrow$

$5 \cos t = 0$  (\*)  $\Rightarrow \cos t = 0 \Rightarrow t = \frac{\pi}{2}$  or  $\frac{3\pi}{2}$ . We check that  $t = \frac{3\pi}{2}$  satisfies (1) and (2) but  $t = \frac{\pi}{2}$  does

not. So the only collision point occurs when  $t = \frac{3\pi}{2}$ , and this gives the point  $(-3, 0)$ . [We could check our work

by graphing  $x_1$  and  $x_2$  together as functions of  $t$  and, on another plot,  $y_1$  and  $y_2$  as functions of  $t$ . If we do so,

we see that the only value of  $t$  for which *both* pairs of graphs intersect is  $t = \frac{3\pi}{2}$ .]

(c) The circle is centered at  $(3, 1)$  instead of  $(-3, 1)$ . There are still 2 intersection points:  $(3, 0)$  and  $(2.1, 1.4)$ , but

there are no collision points, since (\*) in part (b) becomes  $5 \cos t = 6 \Rightarrow \cos t = \frac{6}{5} > 1$ .

44. (a) If  $\alpha = 30^\circ$  and  $v_0 = 500$  m/s, then the equations become  $x = (500 \cos 30^\circ)t = 250\sqrt{3}t$  and

$$y = (500 \sin 30^\circ)t - \frac{1}{2}(9.8)t^2 = 250t - 4.9t^2. \text{ } y = 0 \text{ when } t = 0 \text{ (when the gun is fired) and again when}$$

$$t = \frac{250}{4.9} \approx 51 \text{ s. Then } x = (250\sqrt{3})\left(\frac{250}{4.9}\right) \approx 22,092 \text{ m, so the bullet hits the ground about 22 km from}$$

the gun.

The formula for  $y$  is quadratic in  $t$ . To find the maximum  $y$ -value, we will complete the square:

$$y = -4.9\left(t^2 - \frac{250}{4.9}t\right) = -4.9\left[t^2 - \frac{250}{4.9}t + \left(\frac{125}{4.9}\right)^2\right] + \frac{125^2}{4.9} = -4.9\left(t - \frac{125}{4.9}\right)^2 + \frac{125^2}{4.9} \leq \frac{125^2}{4.9}$$

with equality when  $t = \frac{125}{4.9}$  s, so the maximum height attained is  $\frac{125^2}{4.9} \approx 3189$  m.

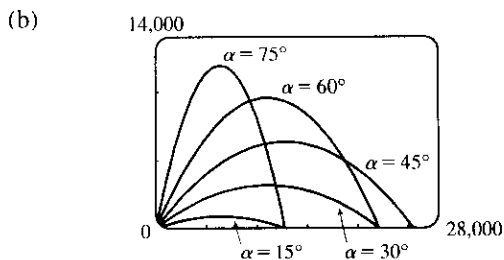

As  $\alpha$  ( $0^\circ < \alpha < 90^\circ$ ) increases up to  $45^\circ$ , the projectile attains a greater height and a greater range. As  $\alpha$  increases past  $45^\circ$ , the projectile attains a greater height, but its range decreases.

(c)  $x = (v_0 \cos \alpha)t \Rightarrow t = \frac{x}{v_0 \cos \alpha}$ .

$$y = (v_0 \sin \alpha)t - \frac{1}{2}gt^2 \Rightarrow y = (v_0 \sin \alpha) \frac{x}{v_0 \cos \alpha} - \frac{g}{2} \left( \frac{x}{v_0 \cos \alpha} \right)^2 = (\tan \alpha)x - \left( \frac{g}{2v_0^2 \cos^2 \alpha} \right) x^2,$$

which is the equation of a parabola (quadratic in  $x$ ).

45.  $x = t^2, y = t^3 - ct$ . We use a graphing device to produce the graphs for various values of  $c$  with  $-\pi \leq t \leq \pi$ .

Note that all the members of the family are symmetric about the  $x$ -axis. For  $c < 0$ , the graph does not cross itself, but for  $c = 0$  it has a cusp at  $(0, 0)$  and for  $c > 0$  the graph crosses itself at  $x = c$ , so the loop grows larger as  $c$  increases.

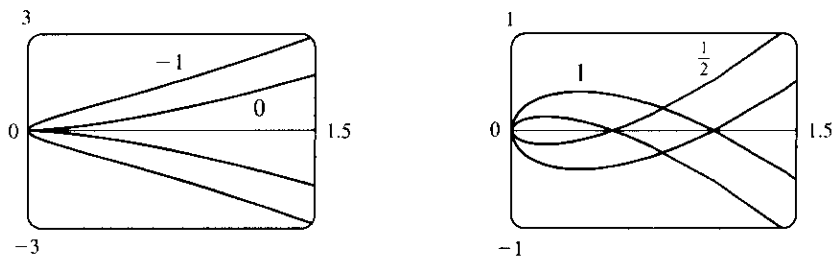

46.  $x = 2ct - 4t^3, y = -ct^2 + 3t^4$ . We use a graphing device to produce the graphs for various values of  $c$  with

$-\pi \leq t \leq \pi$ . Note that all the members of the family are symmetric about the  $y$ -axis. When  $c < 0$ , the graph resembles that of a polynomial of even degree, but when  $c = 0$  there is a corner at the origin, and when  $c > 0$ , the graph crosses itself at the origin, and has two cusps below the  $x$ -axis. The size of the “swallowtail” increases as  $c$  increases.

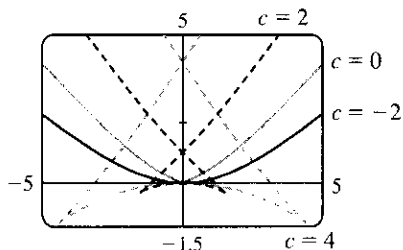

47. Note that all the Lissajous figures are symmetric about the  $x$ -axis. The parameters  $a$  and  $b$  simply stretch the graph in the  $x$ - and  $y$ -directions respectively. For  $a = b = n = 1$  the graph is simply a circle with radius 1. For  $n = 2$  the graph crosses itself at the origin and there are loops above and below the  $x$ -axis. In general, the figures have  $n - 1$  points of intersection, all of which are on the  $y$ -axis, and a total of  $n$  closed loops.

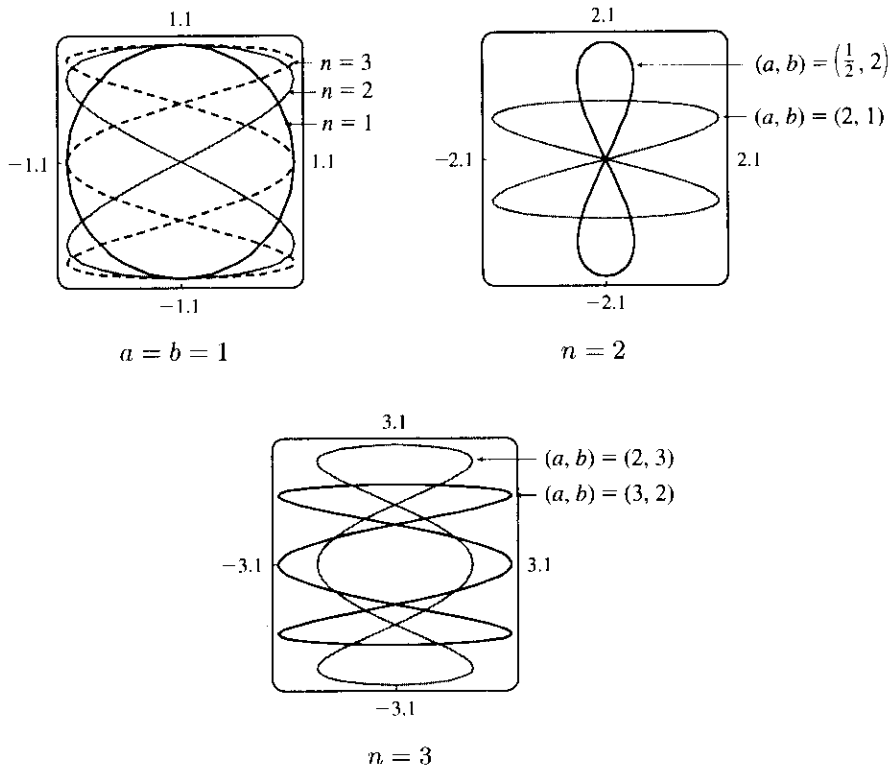

48. We use  $-\pi \leq t \leq \pi$  in the viewing rectangle  $[-4, 2] \times [-3, 3]$ . We first observe that for  $c = 0$ , we obtain a circle with center  $(-\frac{1}{2}, 0)$  and radius  $\frac{1}{2}$ . As the value of  $c$  increases, there is a larger outer loop and a smaller inner loop until  $c = 1$ , when we obtain a curve with a dent (called a **cardioid**). As  $c$  increases, we get a curve with a dimple (called a **limaçon**) until  $c = 2$ . For  $c > 2$ , we have convex limaçons. For negative values of  $c$ , we obtain the same graphs as for positive  $c$ , but with different values of  $t$  corresponding to the points on the curve.

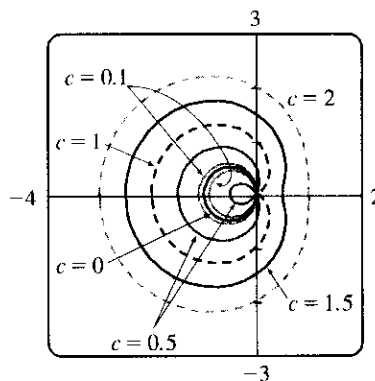

### LABORATORY PROJECT Running Circles Around Circles

1. The center  $Q$  of the smaller circle has coordinates

$((a - b)\cos \theta, (a - b)\sin \theta)$ . Arc  $PS$  on circle  $C$  has length  $a\theta$  since it is equal in length to arc  $AS$  (the smaller circle rolls without slipping against the larger.) Thus,  $\angle PQS = \frac{a}{b}\theta$  and  $\angle PQT = \frac{a}{b}\theta - \theta$ , so  $P$  has coordinates

$$x = (a - b)\cos \theta + b\cos(\angle PQT) = (a - b)\cos \theta + b\cos\left(\frac{a - b}{b}\theta\right)$$

and

$$y = (a - b)\sin \theta - b\sin(\angle PQT) = (a - b)\sin \theta - b\sin\left(\frac{a - b}{b}\theta\right)$$

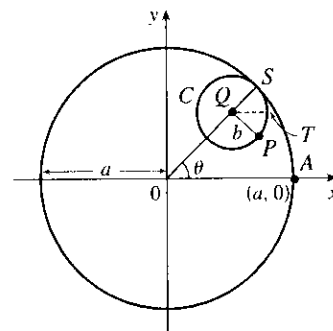

2. With  $b = 1$  and  $a$  a positive integer greater than 2, we obtain a hypocycloid of  $a$  cusps. Shown in the figure is the graph for  $a = 4$ . Let  $a = 4$  and  $b = 1$ . Using the sum identities to expand  $\cos 3\theta$  and  $\sin 3\theta$ , we obtain

$$x = 3\cos \theta + \cos 3\theta = 3\cos \theta + (4\cos^3 \theta - 3\cos \theta) = 4\cos^3 \theta$$

and

$$y = 3\sin \theta - \sin 3\theta = 3\sin \theta - (3\sin \theta - 4\sin^3 \theta) = 4\sin^3 \theta$$

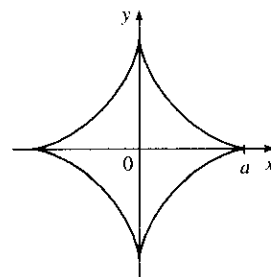

3. The following graphs are obtained with  $b = 1$  and  $a = \frac{1}{2}, \frac{1}{3}, \frac{1}{4},$  and  $\frac{1}{10}$  with  $-2\pi \leq \theta \leq 2\pi$ . We conclude that as the denominator  $d$  increases, the graph gets smaller, but maintains the basic shape shown.

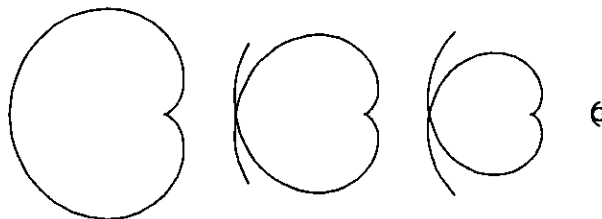

Letting  $d = 2$  and  $n = 3, 5,$  and  $7$  with  $-2\pi \leq \theta \leq 2\pi$  gives us the following:

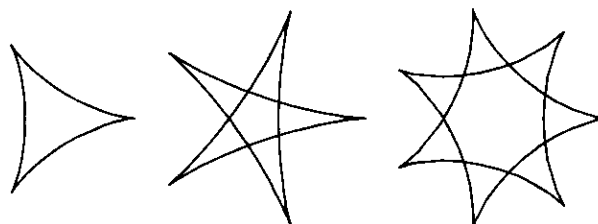

So if  $d$  is held constant and  $n$  varies, we get a graph with  $n$  cusps (assuming  $n/d$  is in lowest form). When  $n = d + 1$ , we obtain a hypocycloid of  $n$  cusps. As  $n$  increases, we must expand the range of  $\theta$  in order to get a closed curve. The following graphs have  $a = \frac{3}{2}$ ,  $\frac{5}{4}$ , and  $\frac{11}{10}$ .

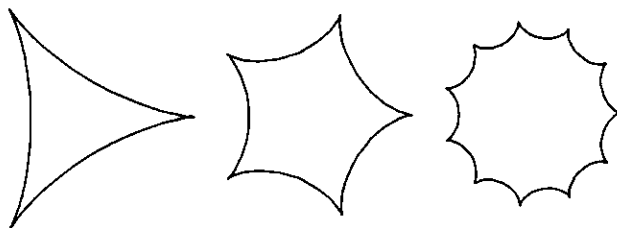

4. If  $b = 1$ , the equations for the hypocycloid are

$$x = (a - 1) \cos \theta + \cos((a - 1) \theta) \quad y = (a - 1) \sin \theta - \sin((a - 1) \theta)$$

which is a hypocycloid of  $a$  cusps (from Problem 2). In general, if  $a > 1$ , we get a figure with cusps on the “outside ring” and if  $a < 1$ , the cusps are on the “inside ring”. In any case, as the values of  $\theta$  get larger, we get a figure that looks more and more like a washer. If we were to graph the hypocycloid for all values of  $\theta$ , every point on the washer would eventually be arbitrarily close to a point on the curve.

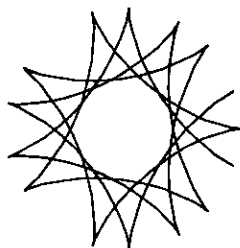

$$a = \sqrt{2} \\ -10\pi \leq \theta \leq 10\pi$$

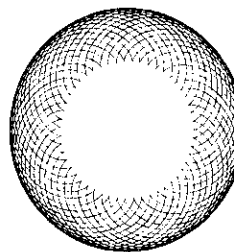

$$a = e - 2 \\ 0 \leq \theta \leq 446$$

5. The center  $Q$  of the smaller circle has coordinates  $((a + b) \cos \theta, (a + b) \sin \theta)$ . Arc

$PS$  has length  $a\theta$  (as in Problem 1), so that  $\angle PQS = \frac{a\theta}{b}$ ,  $\angle PQR = \pi - \frac{a\theta}{b}$ , and

$\angle PQT = \pi - \frac{a\theta}{b} - \theta = \pi - \left(\frac{a+b}{b}\right)\theta$  since  $\angle RQT = \theta$ .

Thus, the coordinates of  $P$  are

$$x = (a + b) \cos \theta + b \cos\left(\pi - \frac{a+b}{b}\theta\right) = (a + b) \cos \theta - b \cos\left(\frac{a+b}{b}\theta\right)$$

and

$$y = (a + b) \sin \theta - b \sin\left(\pi - \frac{a+b}{b}\theta\right) = (a + b) \sin \theta - b \sin\left(\frac{a+b}{b}\theta\right).$$

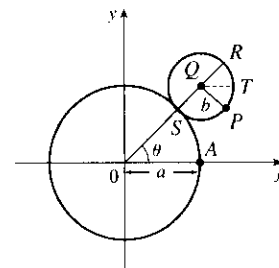

6. Let  $b = 1$  and the equations become

$$x = (a + 1) \cos \theta - \cos((a + 1)\theta)$$

$$y = (a + 1) \sin \theta - \sin((a + 1)\theta)$$

If  $a = 1$ , we have a cardioid. If  $a$  is a positive integer greater than 1, we get the graph of an “ $a$ -leafed clover”, with cusps that are  $a$  units from the origin. (Some of the pairs of figures are not to scale.)

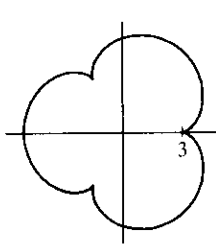

$$a = 3, -2\pi \leq \theta \leq 2\pi$$

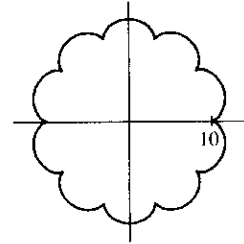

$$a = 10, -2\pi \leq \theta \leq 2\pi$$

If  $a = n/d$  with  $n = 1$ , we obtain a figure that does not increase in size and requires  $-d\pi \leq \theta \leq d\pi$  to be a closed curve traced exactly once.

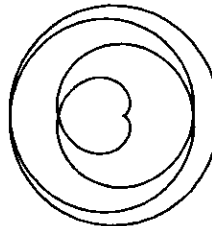

$$a = \frac{1}{4}, -4\pi \leq \theta \leq 4\pi$$

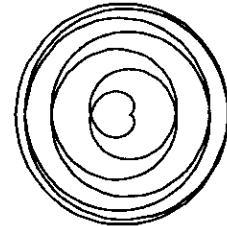

$$a = \frac{1}{7}, -7\pi \leq \theta \leq 7\pi$$

Next, we keep  $d$  constant and let  $n$  vary. As  $n$  increases, so does the size of the figure. There is an  $n$ -pointed star in the middle.

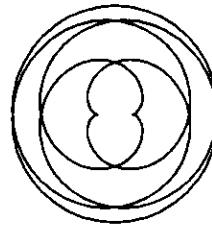

$$a = \frac{2}{5}, -5\pi \leq \theta \leq 5\pi$$

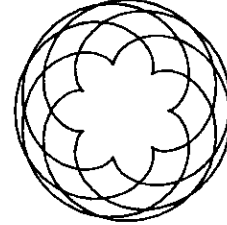

$$a = \frac{7}{5}, -5\pi \leq \theta \leq 5\pi$$

Now if  $n = d + 1$  we obtain figures similar to the previous ones, but the size of the figure does not increase.

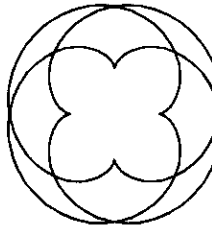

$$a = \frac{4}{3}, -3\pi \leq \theta \leq 3\pi$$

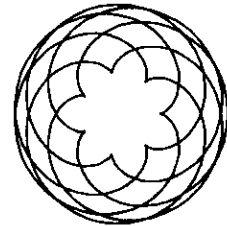

$$a = \frac{7}{6}, -6\pi \leq \theta \leq 6\pi$$

If  $a$  is irrational, we get washers that increase in size as  $a$  increases.

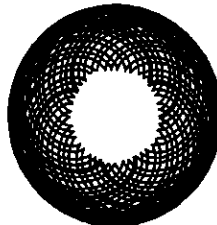

$$a = \sqrt{2}, 0 \leq \theta \leq 200$$

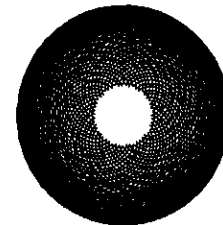

$$a = c - 2, 0 \leq \theta \leq 446$$

## 11.2 Calculus with Parametric Curves

$$1. x = t - t^3, y = 2 - 5t \Rightarrow \frac{dy}{dt} = -5, \frac{dx}{dt} = 1 - 3t^2, \text{ and } \frac{dy}{dx} = \frac{dy/dt}{dx/dt} = \frac{-5}{1 - 3t^2} \text{ or } \frac{5}{3t^2 - 1}.$$

$$2. x = te^t, y = t + e^t \Rightarrow \frac{dy}{dt} = 1 + e^t, \frac{dx}{dt} = te^t + e^t, \text{ and } \frac{dy}{dx} = \frac{dy/dt}{dx/dt} = \frac{1 + e^t}{te^t + e^t}.$$

$$3. x = t^4 + 1, y = t^3 + t; t = -1. \quad \frac{dy}{dt} = 3t^2 + 1, \frac{dx}{dt} = 4t^3, \text{ and } \frac{dy}{dx} = \frac{dy/dt}{dx/dt} = \frac{3t^2 + 1}{4t^3}.$$

When  $t = -1$ ,  $(x, y) = (2, -2)$  and  $dy/dx = \frac{4}{-4} = -1$ , so an equation of the tangent to the curve at the point corresponding to  $t = -1$  is  $y - (-2) = (-1)(x - 2)$ , or  $y = -x$ .

$$4. x = 2t^2 + 1, y = \frac{1}{3}t^3 - t; t = 3. \quad \frac{dy}{dt} = t^2 - 1, \frac{dx}{dt} = 4t, \text{ and } \frac{dy}{dx} = \frac{dy/dt}{dx/dt} = \frac{t^2 - 1}{4t}.$$
 When  $t = 3$ ,

$(x, y) = (19, 6)$  and  $dy/dx = \frac{8}{12} = \frac{2}{3}$ , so an equation of the tangent line is  $y - 6 = \frac{2}{3}(x - 19)$ , or  $y = \frac{2}{3}x - \frac{20}{3}$ .

$$5. x = e^{\sqrt{t}}, y = t - \ln t^2; t = 1. \quad \frac{dy}{dt} = 1 - \frac{2t}{t^2} = 1 - \frac{2}{t}, \frac{dx}{dt} = \frac{e^{\sqrt{t}}}{2\sqrt{t}}, \text{ and}$$

$\frac{dy}{dx} = \frac{dy/dt}{dx/dt} = \frac{1 - 2/t}{e^{\sqrt{t}}/(2\sqrt{t})} \cdot \frac{2t}{2t} = \frac{2t - 4}{\sqrt{t}e^{\sqrt{t}}}$ . When  $t = 1$ ,  $(x, y) = (e, 1)$  and  $\frac{dy}{dx} = -\frac{2}{e}$ , so an equation of the

tangent line is  $y - 1 = -\frac{2}{e}(x - e)$ , or  $y = -\frac{2}{e}x + 3$ .

$$6. x = \cos \theta + \sin 2\theta, y = \sin \theta + \cos 2\theta; \theta = 0. \quad \frac{dy}{dx} = \frac{dy/d\theta}{dx/d\theta} = \frac{\cos \theta - 2 \sin 2\theta}{-\sin \theta + 2 \cos 2\theta}.$$
 When  $\theta = 0$ ,

$(x, y) = (1, 1)$  and  $dy/dx = \frac{1}{2}$ , so an equation of the tangent to the curve is  $y - 1 = \frac{1}{2}(x - 1)$ , or  $y = \frac{1}{2}x + \frac{1}{2}$ .

$$7. (a) x = e^t, y = (t - 1)^2; (1, 1). \quad \frac{dy}{dt} = 2(t - 1), \frac{dx}{dt} = e^t, \text{ and } \frac{dy}{dx} = \frac{dy/dt}{dx/dt} = \frac{2(t - 1)}{e^t}.$$

At  $(1, 1)$ ,  $t = 0$  and  $\frac{dy}{dx} = -2$ , so an equation of the tangent is  $y - 1 = -2(x - 1)$ , or  $y = -2x + 3$ .

$$(b) x = e^t \Rightarrow t = \ln x, \text{ so } y = (t - 1)^2 = (\ln x - 1)^2 \text{ and } \frac{dy}{dx} = 2(\ln x - 1) \left( \frac{1}{x} \right).$$
 When  $x = 1$ ,

$\frac{dy}{dx} = 2(-1)(1) = -2$ , so an equation of the tangent is  $y = -2x + 3$ , as in part (a).

$$8. (a) x = \tan \theta, y = \sec \theta; (1, \sqrt{2}). \quad \frac{dy}{dx} = \frac{dy/d\theta}{dx/d\theta} = \frac{\sec \theta \tan \theta}{\sec^2 \theta} = \frac{\tan \theta}{\sec \theta} = \sin \theta.$$

When  $(x, y) = (1, \sqrt{2})$ ,  $\theta = \frac{\pi}{4}$  (or  $\frac{\pi}{4} + 2\pi n$  for some integer  $n$ ), so  $dy/dx = \sin \frac{\pi}{4} = \frac{\sqrt{2}}{2}$ . Thus, an equation of the tangent to the curve is  $y - \sqrt{2} = (\frac{\sqrt{2}}{2})(x - 1)$ , or  $y = (\frac{\sqrt{2}}{2})x + (\frac{\sqrt{2}}{2})$ .

$$(b) \tan^2 \theta + 1 = \sec^2 \theta \Rightarrow x^2 + 1 = y^2, \text{ so } \frac{d}{dx}(x^2 + 1) = \frac{d}{dx}(y^2) \Rightarrow 2x = 2y \frac{dy}{dx}.$$

When  $(x, y) = (1, \sqrt{2})$ ,  $\frac{dy}{dx} = \frac{x}{y} = \frac{1}{\sqrt{2}} = \frac{\sqrt{2}}{2}$ , so an equation of the tangent is  $y - \sqrt{2} = (\frac{\sqrt{2}}{2})(x - 1)$ ,

as in part (a).



9.  $x = 2 \sin 2t, y = 2 \sin t; (\sqrt{3}, 1)$ .

$$\frac{dy}{dx} = \frac{dy/dt}{dx/dt} = \frac{2 \cos t}{2 \cdot 2 \cos 2t} = \frac{\cos t}{2 \cos 2t}. \text{ The point } (\sqrt{3}, 1) \text{ corresponds}$$

to  $t = \frac{\pi}{6}$ , so the slope of the tangent at that point is

$$\frac{\cos \frac{\pi}{6}}{2 \cos \frac{\pi}{3}} = \frac{\frac{\sqrt{3}}{2}}{2 \cdot \frac{1}{2}} = \frac{\sqrt{3}}{2}. \text{ An equation of the tangent is therefore}$$

$$(y - 1) = \frac{\sqrt{3}}{2}(x - \sqrt{3}), \text{ or } y = \frac{\sqrt{3}}{2}x - \frac{1}{2}.$$

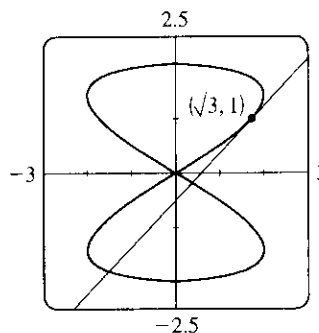

10.  $x = \sin t, y = \sin(t + \sin t); (0, 0)$ .

$$\frac{dy}{dx} = \frac{dy/dt}{dx/dt} = \frac{\cos(t + \sin t)(1 + \cos t)}{\cos t} = (\sec t + 1) \cos(t + \sin t)$$

Note that there are two tangents at the point  $(0, 0)$ , since both  $t = 0$  and  $t = \pi$  correspond to the origin. The tangent corresponding to  $t = 0$  has

slope  $(\sec 0 + 1) \cos(0 + \sin 0) = 2 \cos 0 = 2$ , and its equation is

$y = 2x$ . The tangent corresponding to  $t = \pi$  has slope

$(\sec \pi + 1) \cos(\pi + \sin \pi) = 0$ , so it is the  $x$ -axis.

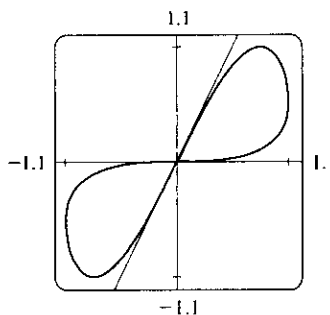

11.  $x = 4 + t^2, y = t^2 + t^3 \Rightarrow \frac{dy}{dx} = \frac{dy/dt}{dx/dt} = \frac{2t + 3t^2}{2t} = 1 + \frac{3}{2}t \Rightarrow$

$$\frac{d^2y}{dx^2} = \frac{d}{dx} \left( \frac{dy}{dx} \right) = \frac{d(dy/dx)/dt}{dx/dt} = \frac{(d/dt)(1 + \frac{3}{2}t)}{2t} = \frac{3/2}{2t} = \frac{3}{4t}. \text{ The curve is CU when } \frac{d^2y}{dx^2} > 0, \text{ that is,}$$

when  $t > 0$ .

12.  $x = t^3 - 12t, y = t^2 - 1 \Rightarrow \frac{dy}{dx} = \frac{dy/dt}{dx/dt} = \frac{2t}{3t^2 - 12} \Rightarrow$

$$\frac{d^2y}{dx^2} = \frac{d}{dx} \left( \frac{dy}{dx} \right) = \frac{(3t^2 - 12) \cdot 2 - 2t(6t)}{(3t^2 - 12)^2} = \frac{-6t^2 - 24}{(3t^2 - 12)^2} = \frac{-6(t^2 + 4)}{(3t^2 - 12)^3} = \frac{-2(t^2 + 4)}{9(t^2 - 4)^3}. \text{ Thus, the curve is}$$

CU when  $t^2 - 4 < 0 \Rightarrow |t| < 2 \Rightarrow -2 < t < 2$ .

13.  $x = t - e^t, y = t + e^{-t} \Rightarrow$

$$\frac{dy}{dx} = \frac{dy/dt}{dx/dt} = \frac{1 - e^{-t}}{1 - e^t} = \frac{1 - \frac{1}{e^t}}{1 - e^t} = \frac{\frac{e^t - 1}{e^t}}{1 - e^t} = -e^{-t} \Rightarrow \frac{d^2y}{dx^2} = \frac{d}{dx} \left( \frac{dy}{dx} \right) = \frac{d}{dt} (-e^{-t}) = \frac{e^{-t}}{1 - e^t}.$$

The curve is CU when  $e^t < 1$  [since  $e^{-t} > 0$ ]  $\Rightarrow t < 0$ .

14.  $x = t + \ln t, y = t - \ln t \Rightarrow \frac{dy}{dx} = \frac{dy/dt}{dx/dt} = \frac{1 - 1/t}{1 + 1/t} = \frac{t - 1}{t + 1} = 1 - \frac{2}{t + 1} \Rightarrow$

$$\frac{d^2y}{dx^2} = \frac{d}{dx} \left( \frac{dy}{dx} \right) = \frac{d}{dt} \left( 1 - \frac{2}{t + 1} \right) = \frac{2/(t + 1)^2}{1 + 1/t} = \frac{2t}{(t + 1)^3}, \text{ so the curve is CU for all } t \text{ in its domain, that}$$

is,  $t > 0$  [ $t < -1$  not in domain].

15.  $x = 2 \sin t$ ,  $y = 3 \cos t$ ,  $0 < t < 2\pi$ .

$$\frac{dy}{dx} = \frac{dy/dt}{dx/dt} = \frac{-3 \sin t}{2 \cos t} = -\frac{3}{2} \tan t, \text{ so } \frac{d^2y}{dx^2} = \frac{d}{dt} \left( \frac{dy}{dx} \right) = \frac{-\frac{3}{2} \sec^2 t}{2 \cos t} = -\frac{3}{4} \sec^3 t.$$

The curve is CU when  $\sec^3 t < 0 \Rightarrow \sec t < 0 \Rightarrow \cos t < 0 \Rightarrow \frac{\pi}{2} < t < \frac{3\pi}{2}$ .

16.  $x = \cos 2t$ ,  $y = \cos t$ ,  $0 < t < \pi$ .  $\frac{dy}{dx} = \frac{dy/dt}{dx/dt} = \frac{-\sin t}{-2 \sin 2t} = \frac{\sin t}{2 \cdot 2 \sin t \cos t} = \frac{1}{4 \cos t} = \frac{1}{4} \sec t$ , so

$$\frac{d^2y}{dx^2} = \frac{d}{dt} \left( \frac{dy}{dx} \right) = \frac{\frac{1}{4} \sec t \tan t}{-4 \sin t \cos t} = -\frac{1}{16} \sec^3 t. \text{ The curve is CU when } \sec^3 t < 0 \Rightarrow \sec t < 0 \Rightarrow$$

$$\cos t < 0 \Rightarrow \frac{\pi}{2} < t < \pi.$$

17.  $x = 10 - t^2$ ,  $y = t^3 - 12t$ .

$$dy/dt = 3t^2 - 12 = 3(t+2)(t-2), \text{ so}$$

$$dy/dt = 0 \Leftrightarrow t = \pm 2 \Leftrightarrow$$

$$(x, y) = (6, \mp 16). \quad dx/dt = -2t, \text{ so } dx/dt = 0$$

$$\Leftrightarrow t = 0 \Leftrightarrow (x, y) = (10, 0). \text{ The curve has}$$

horizontal tangents at  $(6, \pm 16)$  and a vertical

tangent at  $(10, 0)$ .

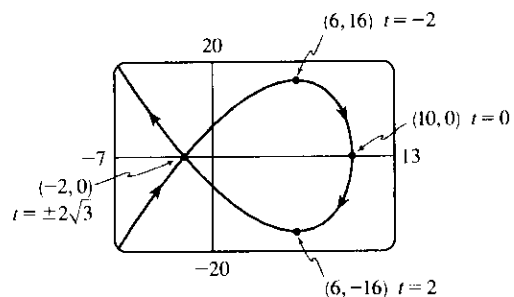

18.  $x = 2t^3 + 3t^2 - 12t$ ,  $y = 2t^3 + 3t^2 + 1$ .

$$dy/dt = 6t^2 + 6t = 6t(t+1), \text{ so } dy/dt = 0 \Leftrightarrow$$

$$t = 0 \text{ or } -1 \Leftrightarrow (x, y) = (0, 1) \text{ or } (13, 2).$$

$$dx/dt = 6t^2 + 6t - 12 = 6(t+2)(t-1), \text{ so}$$

$$dx/dt = 0 \Leftrightarrow t = -2 \text{ or } 1 \Leftrightarrow$$

$(x, y) = (20, -3)$  or  $(-7, 6)$ . The curve has horizontal tangents at  $(0, 1)$  and  $(13, 2)$ , and vertical tangents at  $(20, -3)$  and  $(-7, 6)$ .

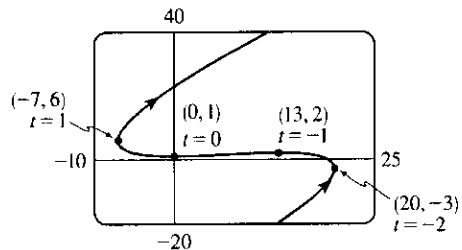

19.  $x = 2 \cos \theta$ ,  $y = \sin 2\theta$ .

$$dy/d\theta = 2 \cos 2\theta, \text{ so } dy/d\theta = 0 \Leftrightarrow$$

$$2\theta = \frac{\pi}{2} + n\pi \quad (n \text{ an integer}) \Leftrightarrow \theta = \frac{\pi}{4} + \frac{\pi}{2}n$$

$$\Leftrightarrow (x, y) = (\pm\sqrt{2}, \pm 1). \text{ Also,}$$

$$dx/d\theta = -2 \sin \theta, \text{ so } dx/d\theta = 0 \Leftrightarrow \theta = n\pi$$

$$\Leftrightarrow (x, y) = (\pm 2, 0). \text{ The curve has horizontal}$$

tangents at  $(\pm\sqrt{2}, \pm 1)$  (four points), and vertical

tangents at  $(\pm 2, 0)$ .

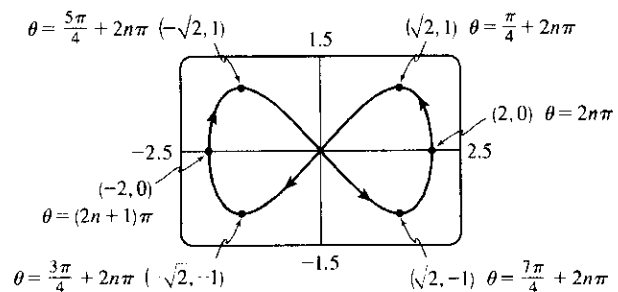

20.  $x = \cos 3\theta$ ,  $y = 2 \sin \theta$ .  $dy/d\theta = 2 \cos \theta$ , so  $dy/d\theta = 0 \Leftrightarrow \theta = \frac{\pi}{2} + n\pi$  ( $n$  an integer)  $\Leftrightarrow (x, y) = (0, \pm 2)$ . Also,  $dx/d\theta = -3 \sin 3\theta$ , so  $dx/d\theta = 0 \Leftrightarrow 3\theta = n\pi \Leftrightarrow \theta = \frac{\pi}{3}n \Leftrightarrow (x, y) = (\pm 1, 0)$  or  $(\pm 1, \pm\sqrt{3})$ . The curve has horizontal tangents at  $(0, \pm 2)$ , and vertical tangents at  $(\pm 1, 0)$ ,  $(\pm 1, -\sqrt{3})$  and  $(\pm 1, \sqrt{3})$ .

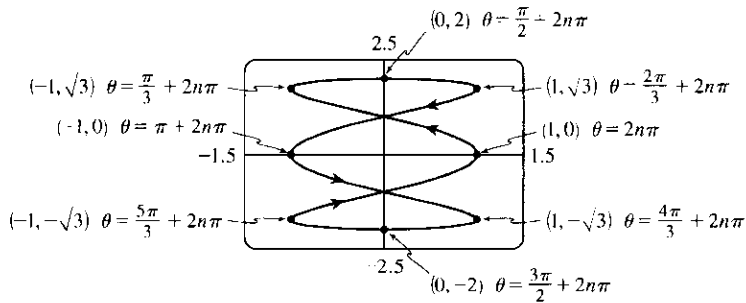

21. From the graph, it appears that the leftmost point on the curve  $x = t^4 - t^2$ ,  $y = t + \ln t$  is about  $(-0.25, 0.36)$ . To find the exact coordinates, we find the value of  $t$  for which the graph has a vertical tangent, that is,

$$0 = dx/dt = 4t^3 - 2t \Leftrightarrow 2t(2t^2 - 1) = 0 \Leftrightarrow 2t(\sqrt{2}t + 1)(\sqrt{2}t - 1) = 0 \Leftrightarrow t = 0 \text{ or } \pm \frac{1}{\sqrt{2}}.$$

The negative and

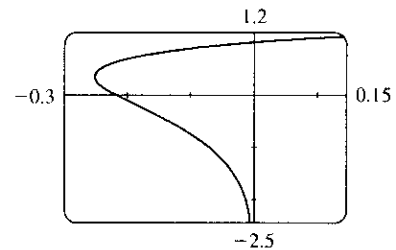

0 roots are inadmissible since  $y(t)$  is only defined for  $t > 0$ , so the leftmost point must be

$$\left(x\left(\frac{1}{\sqrt{2}}\right), y\left(\frac{1}{\sqrt{2}}\right)\right) = \left(\left(\frac{1}{\sqrt{2}}\right)^4 - \left(\frac{1}{\sqrt{2}}\right)^2, \frac{1}{\sqrt{2}} + \ln \frac{1}{\sqrt{2}}\right) = \left(-\frac{1}{4}, \frac{1}{\sqrt{2}} - \frac{1}{2} \ln 2\right)$$

22. The curve is symmetric about the line  $y = -x$  since replacing  $t$  with  $-t$  has the effect of replacing  $(x, y)$  with  $(-y, -x)$ , so if we can find the highest point  $(x_h, y_h)$ , then the leftmost point is  $(x_l, y_l) = (-y_h, -x_h)$ . After carefully zooming in, we estimate that the highest point on the curve  $x = te^t$ ,  $y = te^{-t}$  is about  $(2.7, 0.37)$ .

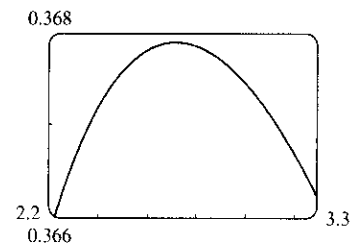
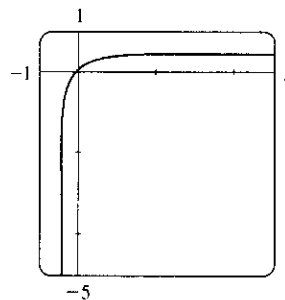

To find the exact coordinates of the highest point, we find the value of  $t$  for which the curve has a horizontal tangent, that is,  $dy/dt = 0 \Leftrightarrow t(-e^{-t}) + e^{-t} = 0 \Leftrightarrow (1 - t)e^{-t} = 0 \Leftrightarrow t = 1$ . This corresponds to the point  $(x(1), y(1)) = (e, 1/e)$ . To find the leftmost point, we find the value of  $t$  for which  $0 = dx/dt = te^t + e^t \Leftrightarrow (1 + t)e^t = 0 \Leftrightarrow t = -1$ . This corresponds to the point  $(x(-1), y(-1)) = (-1/e, -e)$ . As  $t \rightarrow -\infty$ ,  $x(t) = te^t \rightarrow 0^-$  by l'Hospital's Rule and  $y(t) = te^{-t} \rightarrow -\infty$ , so the  $y$ -axis is an asymptote. As  $t \rightarrow \infty$ ,  $x(t) \rightarrow \infty$  and  $y(t) \rightarrow 0^+$ , so the  $x$ -axis is the other asymptote. The asymptotes can also be determined from the graph, if we use a larger  $t$ -interval.

23. We graph the curve  $x = t^4 - 2t^3 - 2t^2$ ,  
 $y = t^3 - t$  in the viewing rectangle  
 $[-2, 1.1]$  by  $[-0.5, 0.5]$ . This rectangle  
 corresponds approximately to  
 $t \in [-1, 0.8]$ . We estimate that the curve  
 has horizontal tangents at about

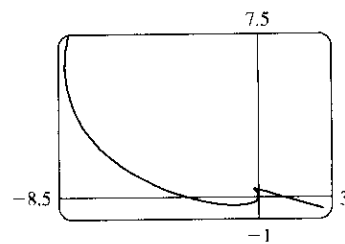
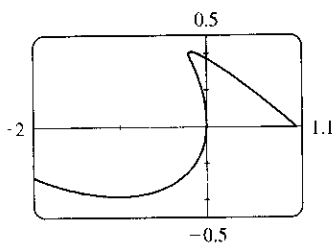

$(-1, -0.4)$  and  $(-0.17, 0.39)$  and vertical tangents at about  $(0, 0)$  and  $(-0.19, 0.37)$ . We calculate

$$\frac{dy}{dx} = \frac{dy/dt}{dx/dt} = \frac{3t^2 - 1}{4t^3 - 6t^2 - 4t}. \text{ The horizontal tangents occur when } dy/dt = 3t^2 - 1 = 0 \Leftrightarrow t = \pm \frac{1}{\sqrt{3}}, \text{ so}$$

both horizontal tangents are shown in our graph. The vertical tangents occur when  $dx/dt = 2t(2t^2 - 3t - 2) = 0$   
 $\Leftrightarrow 2t(2t + 1)(t - 2) = 0 \Leftrightarrow t = 0, -\frac{1}{2}$  or  $2$ . It seems that we have missed one vertical tangent, and indeed if  
 we plot the curve on the  $t$ -interval  $[-1.2, 2.2]$  we see that there is another vertical tangent at  $(-8, 6)$ .

24. We graph the curve  $x = t^4 + 4t^3 - 8t^2$ ,  
 $y = 2t^2 - t$  in the viewing rectangle  
 $[-3.7, 0.2]$  by  $[-0.2, 1.4]$ . It appears  
 that there is a horizontal tangent at about  
 $(-0.4, -0.1)$ , and vertical tangents at  
 about  $(-3, 1)$  and  $(0, 0)$ .

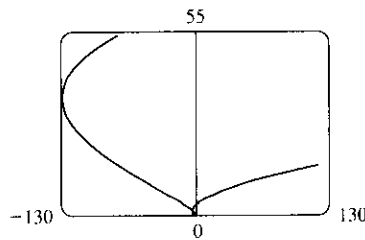
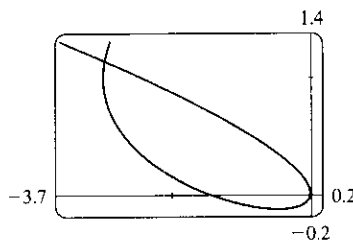

We calculate  $\frac{dy}{dx} = \frac{dy/dt}{dx/dt} = \frac{4t - 1}{4t^3 + 12t^2 - 16t}$ , so there is a horizontal tangent where  $dy/dt = 4t - 1 = 0 \Leftrightarrow$

$t = \frac{1}{4}$ . This point (the lowest point) is shown in the first graph. There are vertical tangents where  
 $dx/dt = 4t^3 + 12t^2 - 16t = 0 \Leftrightarrow 4t(t^2 + 3t - 4) = 0 \Leftrightarrow 4t(t + 4)(t - 1) = 0$ . We have missed one  
 vertical tangent corresponding to  $t = -4$ , and if we plot the graph for  $t \in [-5, 3]$ , we see that the curve has another  
 vertical tangent line at approximately  $(-128, 36)$ .

25.  $x = \cos t$ ,  $y = \sin t \cos t$ .  $\frac{dx}{dt} = -\sin t$ ,  
 $\frac{dy}{dt} = -\sin^2 t + \cos^2 t = \cos 2t$ .  $(x, y) = (0, 0) \Leftrightarrow \cos t = 0 \Leftrightarrow$   
 $t$  is an odd multiple of  $\frac{\pi}{2}$ . When  $t = \frac{\pi}{2}$ ,  $\frac{dx}{dt} = -1$  and  $\frac{dy}{dt} = -1$ , so  
 $\frac{dy}{dx} = 1$ . When  $t = \frac{3\pi}{2}$ ,  $\frac{dx}{dt} = 1$  and  $\frac{dy}{dt} = -1$ . So  $\frac{dy}{dx} = -1$ . Thus,  
 $y = x$  and  $y = -x$  are both tangent to the curve at  $(0, 0)$ .

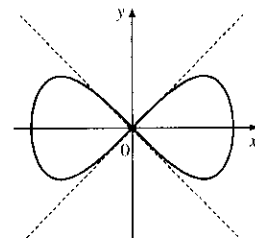

26.  $x = 1 - 2 \cos^2 t = -\cos 2t$ ,  $y = (\tan t)(1 - 2 \cos^2 t) = -(\tan t) \cos 2t$ . To find a point where the curve crosses  
 itself, we look for two values of  $t$  that give the same point  $(x, y)$ . Call these values  $t_1$  and  $t_2$ . Then  
 $\cos^2 t_1 = \cos^2 t_2$  (from the equation for  $x$ ) and either  $\tan t_1 = \tan t_2$  or  $\cos^2 t_1 = \cos^2 t_2 = \frac{1}{2}$  (from the equation  
 for  $y$ ). We can satisfy  $\cos^2 t_1 = \cos^2 t_2$  and  $\tan t_1 = \tan t_2$  by choosing  $t_1$  arbitrarily and taking  $t_2 = t_1 + \pi$ , so  
 evidently the whole curve is retraced every time  $t$  traverses an interval of length  $\pi$ . Thus, we can restrict our  
 attention to the interval  $(-\frac{\pi}{2}, \frac{\pi}{2})$ . If  $t_2 = -t_1$ , then  $\cos^2 t_2 = \cos^2 t_1$ , but  $\tan t_2 = -\tan t_1$ . This suggests that

we try to satisfy the condition  $\cos^2 t_1 = \cos^2 t_2 = \frac{1}{2}$ . Taking  $t_1 = \frac{\pi}{4}$  and  $t_2 = -\frac{\pi}{4}$  gives  $(x, y) = (0, 0)$  for both values of  $t$ .  $\frac{dx}{dt} = 2 \sin 2t$ , and  $\frac{dy}{dt} = 2 \sin 2t \tan t - \cos 2t \sec^2 t$ . When  $t = \frac{\pi}{4}$ ,  $\frac{dx}{dt} = 2$  and  $\frac{dy}{dt} = 2$ , so  $\frac{dy}{dx} = 1$ . When  $t = -\frac{\pi}{4}$ ,  $\frac{dx}{dt} = -2$  and  $\frac{dy}{dt} = 2$ , so  $\frac{dy}{dx} = -1$ . Thus, the equations of the two tangents at  $(0, 0)$  are  $y = x$  and  $y = -x$ .

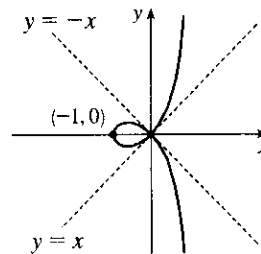

27. (a)  $x = r\theta - d \sin \theta$ ,  $y = r - d \cos \theta$ ;  $\frac{dx}{d\theta} = r - d \cos \theta$ ,  $\frac{dy}{d\theta} = d \sin \theta$ . So  $\frac{dy}{dx} = \frac{d \sin \theta}{r - d \cos \theta}$ .

(b) If  $0 < d < r$ , then  $|d \cos \theta| \leq d < r$ , so  $r - d \cos \theta \geq r - d > 0$ . This shows that  $dx/d\theta$  never vanishes, so the trochoid can have no vertical tangent if  $d < r$ .

28.  $x = a \cos^3 \theta$ ,  $y = a \sin^3 \theta$ .

(a)  $\frac{dx}{d\theta} = -3a \cos^2 \theta \sin \theta$ ,  $\frac{dy}{d\theta} = 3a \sin^2 \theta \cos \theta$ , so  $\frac{dy}{dx} = -\frac{\sin \theta}{\cos \theta} = -\tan \theta$ .

(b) The tangent is horizontal  $\Leftrightarrow dy/dx = 0 \Leftrightarrow \tan \theta = 0 \Leftrightarrow \theta = n\pi \Leftrightarrow (x, y) = (\pm a, 0)$ . The tangent is vertical  $\Leftrightarrow \cos \theta = 0 \Leftrightarrow \theta$  is an odd multiple of  $\frac{\pi}{2} \Leftrightarrow (x, y) = (0, \pm a)$ .

(c)  $dy/dx = \pm 1 \Leftrightarrow \tan \theta = \pm 1 \Leftrightarrow \theta$  is an odd multiple of  $\frac{\pi}{4} \Leftrightarrow (x, y) = \left(\pm \frac{\sqrt{2}}{4}a, \pm \frac{\sqrt{2}}{4}a\right)$  (All sign choices are valid.)

29. The line with parametric equations  $x = -7t$ ,  $y = 12t - 5$  is  $y = 12\left(-\frac{1}{7}x\right) - 5$ , which has slope  $-\frac{12}{7}$ . The curve  $x = t^3 + 4t$ ,  $y = 6t^2$  has slope  $\frac{dy}{dx} = \frac{dy/dt}{dx/dt} = \frac{12t}{3t^2 + 4}$ . This equals  $-\frac{12}{7} \Leftrightarrow 3t^2 + 4 = -7t \Leftrightarrow (3t + 4)(t + 1) = 0 \Leftrightarrow t = -1$  or  $t = -\frac{4}{3} \Leftrightarrow (x, y) = (-5, 6)$  or  $\left(-\frac{208}{27}, \frac{32}{3}\right)$ .

30.  $x = 3t^2 + 1$ ,  $y = 2t^3 + 1$ ,  $\frac{dx}{dt} = 6t$ ,  $\frac{dy}{dt} = 6t^2$ , so  $\frac{dy}{dx} = \frac{6t^2}{6t} = t$  (even where  $t = 0$ ).

So at the point corresponding to parameter value  $t$ , an equation of the tangent line is

$y - (2t^3 + 1) = t[x - (3t^2 + 1)]$ . If this line is to pass through  $(4, 3)$ , we must have

$$3 - (2t^3 + 1) = t[4 - (3t^2 + 1)] \Leftrightarrow 2t^3 - 2 = 3t^3 - 3t \Leftrightarrow t^3 - 3t + 2 = 0 \Leftrightarrow (t - 1)^2(t + 2) = 0$$

$\Leftrightarrow t = 1$  or  $-2$ . Hence, the desired equations are  $y - 3 = x - 4$ , or  $y = x - 1$ , tangent to the curve at  $(4, 3)$ , and  $y - (-15) = -2(x - 13)$ , or  $y = -2x + 11$ , tangent to the curve at  $(13, -15)$ .

31. By symmetry of the ellipse about the  $x$ - and  $y$ -axes,

$$\begin{aligned} A &= 4 \int_0^a y \, dx = 4 \int_{\pi/2}^0 b \sin \theta (-a \sin \theta) \, d\theta = 4ab \int_0^{\pi/2} \sin^2 \theta \, d\theta = 4ab \int_0^{\pi/2} \frac{1}{2}(1 - \cos 2\theta) \, d\theta \\ &= 2ab \left[ \theta - \frac{1}{2} \sin 2\theta \right]_0^{\pi/2} = 2ab \left( \frac{\pi}{2} \right) = \pi ab \end{aligned}$$

32.  $t + 1/t = 2.5 \Leftrightarrow t = \frac{1}{2}$  or  $2$ , and for  $\frac{1}{2} < t < 2$ , we have  $t + 1/t < 2.5$ .  $x = -\frac{3}{2}$  when  $t = \frac{1}{2}$  and  $x = \frac{3}{2}$  when  $t = 2$ .

$$\begin{aligned} A &= \int_{-3/2}^{3/2} (2.5 - y) \, dx = \int_{1/2}^2 \left( \frac{5}{2} - t - 1/t \right) (1 + 1/t^2) \, dt \quad [x = t - 1/t, dx = (1 + 1/t^2) dt] \\ &= \int_{1/2}^2 \left( -t + \frac{5}{2} - 2t^{-1} + \frac{5}{2}t^{-2} - t^{-3} \right) \, dt = \left[ -\frac{t^2}{2} + \frac{5t}{2} - 2 \ln |t| - \frac{5}{2t} + \frac{1}{2t^2} \right]_{1/2}^2 \\ &= \left( -2 + 5 - 2 \ln 2 - \frac{5}{4} + \frac{1}{8} \right) - \left( -\frac{1}{8} + \frac{5}{4} + 2 \ln 2 - 5 + 2 \right) = \frac{15}{4} - 4 \ln 2 \end{aligned}$$

$$33. A = \int_0^1 (y-1) dx = \int_{\pi/2}^0 (e^t - 1)(-\sin t) dt = \int_0^{\pi/2} (e^t \sin t - \sin t) dt \stackrel{98}{=} \left[ \frac{1}{2} e^t (\sin t - \cos t) + \cos t \right]_0^{\pi/2} \\ = \frac{1}{2} (e^{\pi/2} - 1)$$

$$34. \text{ By symmetry, } A = 4 \int_0^a y dx = 4 \int_{\pi/2}^0 a \sin^3 \theta (-3a \cos^2 \theta \sin \theta) d\theta = 12a^2 \int_0^{\pi/2} \sin^4 \theta \cos^2 \theta d\theta. \text{ Now}$$

$$\int \sin^4 \theta \cos^2 \theta d\theta = \int \sin^2 \theta \left( \frac{1}{4} \sin^2 2\theta \right) d\theta = \frac{1}{8} \int (1 - \cos 2\theta) \sin^2 2\theta d\theta \\ = \frac{1}{8} \int \left[ \frac{1}{2} (1 - \cos 4\theta) - \sin^2 2\theta \cos 2\theta \right] d\theta = \frac{1}{16} \theta - \frac{1}{64} \sin 4\theta - \frac{1}{48} \sin^3 2\theta + C$$

$$\text{so } \int_0^{\pi/2} \sin^4 \theta \cos^2 \theta d\theta = \left[ \frac{1}{16} \theta - \frac{1}{64} \sin 4\theta - \frac{1}{48} \sin^3 2\theta \right]_0^{\pi/2} = \frac{\pi}{32}. \text{ Thus, } A = 12a^2 \left( \frac{\pi}{32} \right) = \frac{3}{8} \pi a^2.$$

$$35. A = \int_0^{2\pi r} y dx = \int_0^{2\pi} (r - d \cos \theta)(r - d \cos \theta) d\theta = \int_0^{2\pi} (r^2 - 2dr \cos \theta + d^2 \cos^2 \theta) d\theta \\ = \left[ r^2 \theta - 2dr \sin \theta + \frac{1}{2} d^2 \left( \theta + \frac{1}{2} \sin 2\theta \right) \right]_0^{2\pi} = 2\pi r^2 + \pi d^2$$

36. (a) By symmetry, the area of  $\mathcal{R}$  is twice the area inside  $\mathcal{R}$  above the  $x$ -axis. The top half of the loop is described by  $x = t^2$ ,  $y = t^3 - 3t$ ,  $-\sqrt{3} \leq t \leq 0$ , so, using the Substitution Rule with  $y = t^3 - 3t$  and  $dx = 2t dt$ , we find that

$$\text{area} = 2 \int_0^3 y dx = 2 \int_0^{-\sqrt{3}} (t^3 - 3t) 2t dt = 2 \int_0^{-\sqrt{3}} (2t^4 - 6t^2) dt = 2 \left[ \frac{2}{5} t^5 - 2t^3 \right]_0^{-\sqrt{3}} \\ = 2 \left[ \frac{2}{5} (-3^{1/2})^5 - 2(-3^{1/2})^3 \right] = 2 \left[ \frac{2}{5} (-9\sqrt{3}) - 2(-3\sqrt{3}) \right] = \frac{24}{5} \sqrt{3}$$

(b) Here we use the formula for disks and use the Substitution Rule as in part (a):

$$\text{volume} = \pi \int_0^3 y^2 dx = \pi \int_0^{-\sqrt{3}} (t^3 - 3t)^2 2t dt = 2\pi \int_0^{-\sqrt{3}} (t^6 - 6t^4 + 9t^2) t dt \\ = 2\pi \left[ \frac{1}{8} t^8 - t^6 + \frac{9}{4} t^4 \right]_0^{-\sqrt{3}} = 2\pi \left[ \frac{1}{8} (-3^{1/2})^8 - (-3^{1/2})^6 + \frac{9}{4} (-3^{1/2})^4 \right] \\ = 2\pi \left[ \frac{81}{8} - 27 + \frac{81}{4} \right] = \frac{27}{4} \pi$$

(c) By symmetry, the  $y$ -coordinate of the centroid is 0. To find the  $x$ -coordinate, we note that it is the same as the  $x$ -coordinate of the centroid of the top half of  $\mathcal{R}$ , the area of which is  $\frac{1}{2} \cdot \frac{24}{5} \sqrt{3} = \frac{12}{5} \sqrt{3}$ . So, using

Formula 9.3.8 with  $A = \frac{12}{5} \sqrt{3}$ , we get

$$\bar{x} = \frac{5}{12\sqrt{3}} \int_0^3 xy dx = \frac{5}{12\sqrt{3}} \int_0^{-\sqrt{3}} t^2 (t^3 - 3t) 2t dt = \frac{5}{6\sqrt{3}} \left[ \frac{1}{7} t^7 - \frac{3}{5} t^5 \right]_0^{-\sqrt{3}} \\ = \frac{5}{6\sqrt{3}} \left[ \frac{1}{7} (-3^{1/2})^7 - \frac{3}{5} (-3^{1/2})^5 \right] = \frac{5}{6\sqrt{3}} \left[ -\frac{27}{7} \sqrt{3} + \frac{27}{5} \sqrt{3} \right] = \frac{9}{7}$$

So the coordinates of the centroid of  $\mathcal{R}$  are  $(x, y) = \left( \frac{9}{7}, 0 \right)$ .

$$37. x = t - t^2, y = \frac{4}{3} t^{3/2}, 1 \leq t \leq 2. dx/dt = 1 - 2t \text{ and } dy/dt = 2t^{1/2}, \text{ so}$$

$$(dx/dt)^2 + (dy/dt)^2 = (1 - 2t)^2 + (2t^{1/2})^2 = 1 - 4t + 4t^2 + 4t = 1 + 4t^2. \text{ Thus,}$$

$$L = \int_a^b \sqrt{(dx/dt)^2 + (dy/dt)^2} dt = \int_1^2 \sqrt{1 + 4t^2} dt.$$

$$38. x = 1 + e^t, y = t^2, -3 \leq t \leq 3. dx/dt = e^t \text{ and } dy/dt = 2t, \text{ so } (dx/dt)^2 + (dy/dt)^2 = e^{2t} + 4t^2. \text{ Thus,}$$

$$L = \int_a^b \sqrt{(dx/dt)^2 + (dy/dt)^2} dt = \int_{-3}^3 \sqrt{e^{2t} + 4t^2} dt.$$

$$39. x = t + \cos t, y = t - \sin t, 0 \leq t \leq 2\pi. dx/dt = 1 - \sin t \text{ and } dy/dt = 1 - \cos t, \text{ so}$$

$$(dx/dt)^2 + (dy/dt)^2 = (1 - \sin t)^2 + (1 - \cos t)^2 = (1 - 2\sin t + \sin^2 t) + (1 - 2\cos t + \cos^2 t)$$

$$= 3 - 2\sin t - 2\cos t$$

$$\text{Thus, } L = \int_a^b \sqrt{(dx/dt)^2 + (dy/dt)^2} dt = \int_0^{2\pi} \sqrt{3 - 2\sin t - 2\cos t} dt.$$

40.  $x = \ln t, y = \sqrt{t+1}, 1 \leq t \leq 5. \frac{dx}{dt} = \frac{1}{t}$  and  $\frac{dy}{dt} = \frac{1}{2\sqrt{t+1}}$ , so

$$\left(\frac{dx}{dt}\right)^2 + \left(\frac{dy}{dt}\right)^2 = \frac{1}{t^2} + \frac{1}{4(t+1)} = \frac{t^2 + 4t + 4}{4t^2(t+1)}. \text{ Thus,}$$

$$L = \int_a^b \sqrt{\left(\frac{dx}{dt}\right)^2 + \left(\frac{dy}{dt}\right)^2} dt = \int_1^5 \sqrt{\frac{t^2 + 4t + 4}{4t^2(t+1)}} dt = \int_1^5 \sqrt{\frac{(t+2)^2}{(2t)^2(t+1)}} dt = \int_1^5 \frac{t+2}{2t\sqrt{t+1}} dt.$$

41.  $x = 1 + 3t^2, y = 4 + 2t^3, 0 \leq t \leq 1. dx/dt = 6t$  and  $dy/dt = 6t^2$ , so  $(dx/dt)^2 + (dy/dt)^2 = 36t^2 + 36t^4$ .

$$\text{Thus, } L = \int_0^1 \sqrt{36t^2 + 36t^4} dt = \int_0^1 6t \sqrt{1+t^2} dt = 6 \int_1^2 \sqrt{u} \left(\frac{1}{2} du\right) \quad [u = 1+t^2, du = 2t dt]$$

$$= 3 \left[ \frac{2}{3} u^{3/2} \right]_1^2 = 2(2^{3/2} - 1) = 2(2\sqrt{2} - 1)$$

42.  $x = a(\cos \theta + \theta \sin \theta), y = a(\sin \theta - \theta \cos \theta), 0 \leq \theta \leq \pi.$

$$\begin{aligned} (dx/d\theta)^2 + (dy/d\theta)^2 &= a^2 [(-\sin \theta + \theta \cos \theta + \sin \theta)^2 + (\cos \theta + \theta \sin \theta - \cos \theta)^2] \\ &= a^2 \theta^2 (\cos^2 \theta + \sin^2 \theta) = (a\theta)^2 \end{aligned}$$

$$\text{Thus, } L = \int_0^\pi a\theta d\theta = a \left[ \frac{1}{2} \theta^2 \right]_0^\pi = \frac{1}{2} \pi^2 a.$$

43.  $x = \frac{t}{1+t}, y = \ln(1+t), 0 \leq t \leq 2. \frac{dx}{dt} = \frac{(1+t) \cdot 1 - t \cdot 1}{(1+t)^2} = \frac{1}{(1+t)^2}$  and  $\frac{dy}{dt} = \frac{1}{1+t}$ , so

$$\left(\frac{dx}{dt}\right)^2 + \left(\frac{dy}{dt}\right)^2 = \frac{1}{(1+t)^4} + \frac{1}{(1+t)^2} = \frac{1}{(1+t)^4} [1 + (1+t)^2] = \frac{t^2 + 2t + 2}{(1+t)^4}. \text{ Thus,}$$

$$\begin{aligned} L &= \int_0^2 \frac{\sqrt{t^2 + 2t + 2}}{(1+t)^2} dt = \int_1^3 \frac{\sqrt{u^2 + 1}}{u^2} du \quad [u = t+1, du = dt] \stackrel{24}{=} \left[ -\frac{\sqrt{u^2 + 1}}{u} + \ln(u + \sqrt{u^2 + 1}) \right]_1^3 \\ &= -\frac{\sqrt{10}}{3} + \ln(3 + \sqrt{10}) + \sqrt{2} - \ln(1 + \sqrt{2}) \end{aligned}$$

44.  $x = e^t + e^{-t}, y = 5 - 2t, 0 \leq t \leq 3. dx/dt = e^t - e^{-t}$  and  $dy/dt = -2$ , so

$$(dx/dt)^2 + (dy/dt)^2 = e^{2t} - 2 + e^{-2t} + 4 = e^{2t} + 2 + e^{-2t} = (e^t + e^{-t})^2. \text{ Thus,}$$

$$L = \int_0^3 (e^t + e^{-t}) dt = [e^t - e^{-t}]_0^3 = e^3 - e^{-3} - (1 - 1) = e^3 - e^{-3}.$$

45.  $x = e^t \cos t, y = e^t \sin t, 0 \leq t \leq \pi.$

$$\begin{aligned} \left(\frac{dx}{dt}\right)^2 + \left(\frac{dy}{dt}\right)^2 &= [e^t(\cos t - \sin t)]^2 + [e^t(\sin t + \cos t)]^2 \\ &= (e^t)^2 (\cos^2 t - 2 \cos t \sin t + \sin^2 t) \\ &\quad + (e^t)^2 (\sin^2 t + 2 \sin t \cos t + \cos^2 t) \\ &= e^{2t} (2 \cos^2 t + 2 \sin^2 t) = 2e^{2t} \end{aligned}$$

$$\text{Thus, } L = \int_0^\pi \sqrt{2e^{2t}} dt = \int_0^\pi \sqrt{2} e^t dt = \sqrt{2} [e^t]_0^\pi = \sqrt{2}(e^\pi - 1).$$

46.  $x = \cos t + \ln(\tan \frac{1}{2}t), y = \sin t, \pi/4 \leq t \leq 3\pi/4.$

$$\frac{dx}{dt} = -\sin t + \frac{1}{2} \frac{\sec^2(t/2)}{\tan(t/2)} = -\sin t + \frac{1}{2 \sin(t/2) \cos(t/2)} = -\sin t + \frac{1}{\sin t}$$

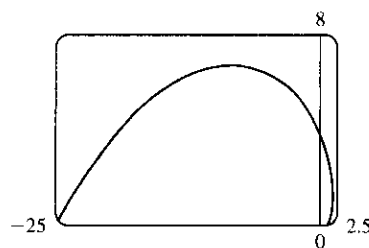

and  $\frac{dy}{dt} = \cos t$ , so  $\left(\frac{dx}{dt}\right)^2 + \left(\frac{dy}{dt}\right)^2 = \sin^2 t - 2 + \frac{1}{\sin^2 t} + \cos^2 t = 1 - 2 + \csc^2 t = \cot^2 t$ . Thus,

$$L = \int_{\pi/4}^{3\pi/4} |\cot t| dt = 2 \int_{\pi/4}^{\pi/2} \cot t dt = 2[\ln|\sin t|]_{\pi/4}^{\pi/2} = 2\left(\ln 1 - \ln \frac{1}{\sqrt{2}}\right) = 2\left(0 + \ln \sqrt{2}\right) = 2\left(\frac{1}{2} \ln 2\right) = \ln 2.$$

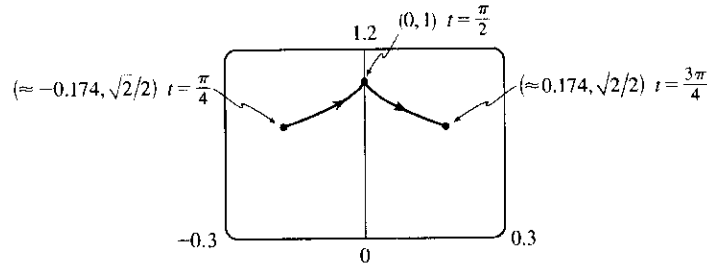

47.  $x = e^t - t, y = 4e^{t/2}, -8 \leq t \leq 3$ .

$$\begin{aligned} \left(\frac{dx}{dt}\right)^2 + \left(\frac{dy}{dt}\right)^2 &= (e^t - 1)^2 + (2e^{t/2})^2 = e^{2t} - 2e^t + 1 + 4e^t \\ &= e^{2t} + 2e^t + 1 = (e^t + 1)^2 \end{aligned}$$

Thus,

$$\begin{aligned} L &= \int_{-8}^3 \sqrt{(e^t + 1)^2} dt = \int_{-8}^3 (e^t + 1) dt = [e^t + t]_{-8}^3 \\ &= (e^3 + 3) - (e^{-8} - 8) = e^3 - e^{-8} + 11. \end{aligned}$$

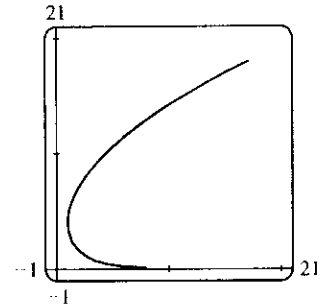

48.  $x = 3t - t^3, y = 3t^2, dx/dt = 3 - 3t^2$  and  $dy/dt = 6t$ , so

$$\left(\frac{dx}{dt}\right)^2 + \left(\frac{dy}{dt}\right)^2 = (3 - 3t^2)^2 + (6t)^2 = (3 + 3t^2)^2$$

and the length of the loop is given by

$$\begin{aligned} L &= \int_{-\sqrt{3}}^{\sqrt{3}} (3 + 3t^2) dt = 2 \int_0^{\sqrt{3}} (3 + 3t^2) dt = 2[3t + t^3]_0^{\sqrt{3}} \\ &= 2(3\sqrt{3} + 3\sqrt{3}) = 12\sqrt{3}. \end{aligned}$$

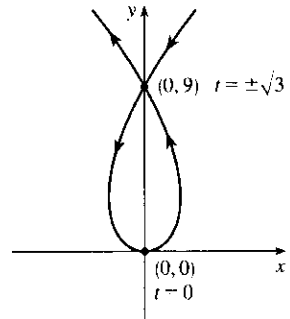

49.  $x = t - e^t, y = t + e^t, -6 \leq t \leq 6$ .

$$\left(\frac{dx}{dt}\right)^2 + \left(\frac{dy}{dt}\right)^2 = (1 - e^t)^2 + (1 + e^t)^2 = (1 - 2e^t + e^{2t}) + (1 + 2e^t + e^{2t}) = 2 + 2e^{2t},$$

so  $L = \int_{-6}^6 \sqrt{2 + 2e^{2t}} dt$ . Set  $f(t) = \sqrt{2 + 2e^{2t}}$ . Then by Simpson's Rule with  $n = 6$  and  $\Delta t = \frac{6 - (-6)}{6} = 2$ , we get  $L \approx \frac{2}{3}[f(-6) + 4f(-4) + 2f(-2) + 4f(0) + 2f(2) + 4f(4) + f(6)] \approx 612.3053$ .

50.  $x = 2a \cot \theta \Rightarrow dx/dt = -2a \csc^2 \theta$  and  $y = 2a \sin^2 \theta \Rightarrow dy/dt = 4a \sin \theta \cos \theta = 2a \sin 2\theta$ .

So  $L = \int_{\pi/4}^{\pi/2} \sqrt{4a^2 \csc^4 \theta + 4a^2 \sin^2 2\theta} d\theta = 2a \int_{\pi/4}^{\pi/2} \sqrt{\csc^4 \theta + \sin^2 2\theta} d\theta$ . Using Simpson's

Rule with  $n = 4, \Delta\theta = \frac{\pi/2 - \pi/4}{4} = \frac{\pi}{16}$ , and  $f(\theta) = \sqrt{\csc^4 \theta + \sin^2 2\theta}$ , we get

$$L \approx 2a \cdot S_4 = (2a) \frac{\pi}{16 \cdot 3} [f(\frac{\pi}{4}) + 4f(\frac{5\pi}{16}) + 2f(\frac{3\pi}{8}) + 4f(\frac{7\pi}{16}) + f(\frac{\pi}{2})] \approx 2.2605a.$$



51.  $x = \sin^2 t, y = \cos^2 t, 0 \leq t \leq 3\pi.$

$$(dx/dt)^2 + (dy/dt)^2 = (2 \sin t \cos t)^2 + (-2 \cos t \sin t)^2 = 8 \sin^2 t \cos^2 t = 2 \sin^2 2t \Rightarrow$$

$$\begin{aligned} \text{Distance} &= \int_0^{3\pi} \sqrt{2} |\sin 2t| dt = 6 \sqrt{2} \int_0^{\pi/2} \sin 2t dt \text{ [by symmetry]} = -3 \sqrt{2} [\cos 2t]_0^{\pi/2} \\ &= -3 \sqrt{2} (-1 - 1) = 6 \sqrt{2} \end{aligned}$$

The full curve is traversed as  $t$  goes from 0 to  $\frac{\pi}{2}$ , because the curve is the segment of  $x + y = 1$  that lies in the first quadrant (since  $x, y \geq 0$ ), and this segment is completely traversed as  $t$  goes from 0 to  $\frac{\pi}{2}$ .

Thus,  $L = \int_0^{\pi/2} \sin 2t dt = \sqrt{2}$ , as above.

52.  $x = \cos^2 t, y = \cos t, 0 \leq t \leq 4\pi. \left(\frac{dx}{dt}\right)^2 + \left(\frac{dy}{dt}\right)^2 = (-2 \cos t \sin t)^2 + (-\sin t)^2 = \sin^2 t(4 \cos^2 t + 1)$

$$\begin{aligned} \text{Distance} &= \int_0^{4\pi} |\sin t| \sqrt{4 \cos^2 t + 1} dt = 4 \int_0^{\pi} \sin t \sqrt{4 \cos^2 t + 1} dt \\ &= -4 \int_1^{-1} \sqrt{4u^2 + 1} du \text{ [} u = \cos t, du = -\sin t dt \text{]} = 4 \int_{-1}^1 \sqrt{4u^2 + 1} du = 8 \int_0^1 \sqrt{4u^2 + 1} du \\ &= 8 \int_0^{\tan^{-1} 2} \sec \theta \cdot \frac{1}{2} \sec^2 \theta d\theta \text{ [} 2u = \tan \theta, 2 du = \sec^2 \theta d\theta \text{]} \\ &= 4 \int_0^{\tan^{-1} 2} \sec^3 \theta d\theta \stackrel{71}{=} [2 \sec \theta \tan \theta + 2 \ln |\sec \theta + \tan \theta|]_0^{\tan^{-1} 2} = 4 \sqrt{5} + 2 \ln(\sqrt{5} + 2) \end{aligned}$$

Thus,  $L = \int_0^{\pi} |\sin t| \sqrt{4 \cos^2 t + 1} dt = \sqrt{5} + \frac{1}{2} \ln(\sqrt{5} + 2).$

53.  $x = a \sin \theta, y = b \cos \theta, 0 \leq \theta \leq 2\pi.$

$$\begin{aligned} \left(\frac{dx}{d\theta}\right)^2 + \left(\frac{dy}{d\theta}\right)^2 &= (a \cos \theta)^2 + (-b \sin \theta)^2 = a^2 \cos^2 \theta + b^2 \sin^2 \theta = a^2(1 - \sin^2 \theta) + b^2 \sin^2 \theta \\ &= a^2 - (a^2 - b^2) \sin^2 \theta = a^2 - c^2 \sin^2 \theta = a^2 \left(1 - \frac{c^2}{a^2} \sin^2 \theta\right) = a^2(1 - e^2 \sin^2 \theta) \end{aligned}$$

So  $L = 4 \int_0^{\pi/2} \sqrt{a^2(1 - e^2 \sin^2 \theta)} d\theta$  [by symmetry]  $= 4a \int_0^{\pi/2} \sqrt{1 - e^2 \sin^2 \theta} d\theta.$

54.  $x = a \cos^3 \theta, y = a \sin^3 \theta.$

$$\begin{aligned} (dx/d\theta)^2 + (dy/d\theta)^2 &= (-3a \cos^2 \theta \sin \theta)^2 + (3a \sin^2 \theta \cos \theta)^2 \\ &= 9a^2 \cos^4 \theta \sin^2 \theta + 9a^2 \sin^4 \theta \cos^2 \theta \\ &= 9a^2 \sin^2 \theta \cos^2 \theta (\cos^2 \theta + \sin^2 \theta) = 9a^2 \sin^2 \theta \cos^2 \theta. \end{aligned}$$

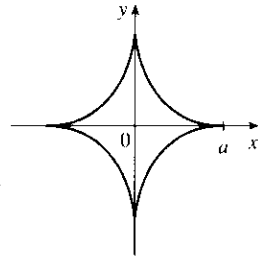

The graph has four-fold symmetry and the curve in the first quadrant corresponds to  $0 \leq \theta \leq \pi/2$ . Thus,

$$\begin{aligned} L &= 4 \int_0^{\pi/2} 3a \sin \theta \cos \theta d\theta \text{ [since } a > 0 \text{ and } \sin \theta \text{ and } \cos \theta \text{ are positive for } 0 \leq \theta \leq \pi/2 \text{]} \\ &= 12a \left[\frac{1}{2} \sin^2 \theta\right]_0^{\pi/2} = 12a \left(\frac{1}{2} - 0\right) = 6a. \end{aligned}$$

55. (a) Notice that  $0 \leq t \leq 2\pi$  does not give the complete curve

because  $x(0) \neq x(2\pi)$ . In fact, we must take  $t \in [0, 4\pi]$  in order to obtain the complete curve, since the first term in each of the parametric equations has period  $2\pi$  and the second has period  $\frac{2\pi}{11/2} = \frac{4\pi}{11}$ , and the least common integer multiple of these two numbers is  $4\pi$ .

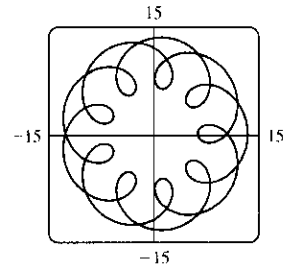

(b) We use the CAS to find the derivatives  $dx/dt$  and  $dy/dt$ , and then use Formula 1 to find the arc length. Recent versions of Maple express the integral  $\int_0^{4\pi} \sqrt{(dx/dt)^2 + (dy/dt)^2} dt$  as  $88E(2\sqrt{2}i)$ , where  $E(x)$  is the elliptic integral  $\int_0^1 \frac{\sqrt{1-x^2t^2}}{\sqrt{1-t^2}} dt$  and  $i$  is the imaginary number  $\sqrt{-1}$ . Some earlier versions of Maple (as well as Mathematica) cannot do the integral exactly, so we use the command `evalf(Int(sqrt(diff(x,t)^2+diff(y,t)^2),t=0..4*Pi))`; to estimate the length, and find that the arc length is approximately 294.03. Derive's `Para_arc_length` function in the utility file `Int_apps` simplifies the integral to  $11 \int_0^{4\pi} \sqrt{-4 \cos t \cos(\frac{11t}{2}) - 4 \sin t \sin(\frac{11t}{2}) + 5} dt$ .

56. (a) It appears that as  $t \rightarrow \infty$ ,  $(x, y) \rightarrow (\frac{1}{2}, \frac{1}{2})$ , and

as  $t \rightarrow -\infty$ ,  $(x, y) \rightarrow (-\frac{1}{2}, -\frac{1}{2})$ .

(b) By the Fundamental Theorem of Calculus,

$dx/dt = \cos(\frac{\pi}{2}t^2)$  and  $dy/dt = \sin(\frac{\pi}{2}t^2)$ , so

by Formula 6, the length of the curve from the origin to the point with parameter value  $t$  is

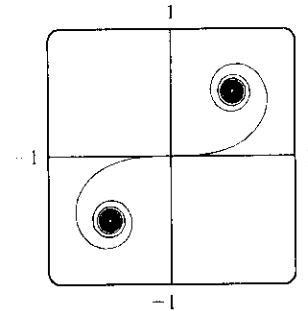

$$\begin{aligned} L &= \int_0^t \sqrt{(dx/du)^2 + (dy/du)^2} du = \int_0^t \sqrt{\cos^2(\frac{\pi}{2}u^2) + \sin^2(\frac{\pi}{2}u^2)} du \\ &= \int_0^t 1 du = t \quad [\text{or } -t \text{ if } t < 0] \end{aligned}$$

We have used  $u$  as the dummy variable so as not to confuse it with the upper limit of integration.

57.  $x = t - t^2$ ,  $y = \frac{4}{3}t^{3/2}$ ,  $1 \leq t \leq 2$ .  $\left(\frac{dx}{dt}\right)^2 + \left(\frac{dy}{dt}\right)^2 = (1 - 2t)^2 + (2t^{1/2})^2 = 1 - 4t + 4t^2 + 4t = 1 + 4t^2$ ,

so  $S = \int_1^2 2\pi y ds = \int_1^2 2\pi \cdot \frac{4}{3}t^{3/2} \sqrt{1 + 4t^2} dt = \int_1^2 \frac{8\pi}{3}t^{3/2} \sqrt{1 + 4t^2} dt$ .

58.  $x = \sin^2 t$ ,  $y = \sin 3t$ ,  $0 \leq t \leq \frac{\pi}{3}$ .  $dx/dt = 2 \sin t \cos t = \sin 2t$  and  $dy/dt = 3 \cos 3t$ , so

$(dx/dt)^2 + (dy/dt)^2 = \sin^2 2t + 9 \cos^2 3t$  and  $S = \int 2\pi y ds = \int_0^{\pi/3} 2\pi \sin 3t \sqrt{\sin^2 2t + 9 \cos^2 3t} dt$ .

59.  $x = t^3$ ,  $y = t^2$ ,  $0 \leq t \leq 1$ .  $\left(\frac{dx}{dt}\right)^2 + \left(\frac{dy}{dt}\right)^2 = (3t^2)^2 + (2t)^2 = 9t^4 + 4t^2$ .

$$\begin{aligned} S &= \int_0^1 2\pi y \sqrt{\left(\frac{dx}{dt}\right)^2 + \left(\frac{dy}{dt}\right)^2} dt = \int_0^1 2\pi t^2 \sqrt{9t^4 + 4t^2} dt = 2\pi \int_0^1 t^2 \sqrt{t^2(9t^2 + 4)} dt \\ &= 2\pi \int_4^{13} \left(\frac{u-4}{9}\right) \sqrt{u} \left(\frac{1}{18} du\right) \quad \left[ \begin{array}{l} u = 9t^2 + 4, t^2 = (u-4)/9 \\ du = 18t dt, \text{ so } t dt = \frac{1}{18} du \end{array} \right] = \frac{2\pi}{9 \cdot 18} \int_4^{13} (u^{3/2} - 4u^{1/2}) du \\ &= \frac{\pi}{81} \left[ \frac{2}{5} u^{5/2} - \frac{8}{3} u^{3/2} \right]_4^{13} = \frac{\pi}{81} \cdot \frac{2}{15} [3u^{5/2} - 20u^{3/2}]_4^{13} \\ &= \frac{2\pi}{1215} \left[ (3 \cdot 13^2 \sqrt{13} - 20 \cdot 13 \sqrt{13}) - (3 \cdot 32 - 20 \cdot 8) \right] \\ &= \frac{2\pi}{1215} (247 \sqrt{13} + 64) \end{aligned}$$

60.  $x = 3t - t^3$ ,  $y = 3t^2$ ,  $0 \leq t \leq 1$ .  $\left(\frac{dx}{dt}\right)^2 + \left(\frac{dy}{dt}\right)^2 = (3 - 3t^2)^2 + (6t)^2 = 9(1 + 2t^2 + t^4) = [3(1 + t^2)]^2$ .

$S = \int_0^1 2\pi \cdot 3t^2 \cdot 3(1 + t^2) dt = 18\pi \int_0^1 (t^2 + t^4) dt = 18\pi \left[ \frac{1}{3}t^3 + \frac{1}{5}t^5 \right]_0^1 = \frac{48}{5}\pi$

$$61. x = a \cos^3 \theta, y = a \sin^3 \theta, 0 \leq \theta \leq \frac{\pi}{2}.$$

$$\left(\frac{dx}{d\theta}\right)^2 + \left(\frac{dy}{d\theta}\right)^2 = (-3a \cos^2 \theta \sin \theta)^2 + (3a \sin^2 \theta \cos \theta)^2 = 9a^2 \sin^2 \theta \cos^2 \theta.$$

$$S = \int_0^{\pi/2} 2\pi \cdot a \sin^3 \theta \cdot 3a \sin \theta \cos \theta d\theta = 6\pi a^2 \int_0^{\pi/2} \sin^4 \theta \cos \theta d\theta = \frac{6}{5}\pi a^2 [\sin^5 \theta]_0^{\pi/2} = \frac{6}{5}\pi a^2$$

$$62. \left(\frac{dx}{d\theta}\right)^2 + \left(\frac{dy}{d\theta}\right)^2 = (-2 \sin \theta + 2 \sin 2\theta)^2 + (2 \cos \theta - 2 \cos 2\theta)^2$$

$$= 4[(\sin^2 \theta - 2 \sin \theta \sin 2\theta + \sin^2 2\theta) + (\cos^2 \theta - 2 \cos \theta \cos 2\theta + \cos^2 2\theta)]$$

$$= 4[1 + 1 - 2(\cos 2\theta \cos \theta + \sin 2\theta \sin \theta)] = 8[1 - \cos(2\theta - \theta)] = 8(1 - \cos \theta)$$

We plot the graph with parameter interval  $[0, 2\pi]$ , and see that we should only integrate between 0 and  $\pi$ . (If the interval  $[0, 2\pi]$  were taken, the surface of revolution would be generated twice.) Also note that  $y = 2 \sin \theta - \sin 2\theta = 2 \sin \theta(1 - \cos \theta)$ . So

$$S = \int_0^{\pi} 2\pi \cdot 2 \sin \theta(1 - \cos \theta) 2\sqrt{2}\sqrt{1 - \cos \theta} d\theta$$

$$= 8\sqrt{2}\pi \int_0^{\pi} (1 - \cos \theta)^{3/2} \sin \theta d\theta$$

$$= 8\sqrt{2}\pi \int_0^2 \sqrt{u^3} du \quad [\text{where } u = 1 - \cos \theta, du = \sin \theta d\theta]$$

$$= 8\sqrt{2}\pi \left[\frac{2}{5}u^{5/2}\right]_0^2 = \frac{16}{5}\sqrt{2}\pi(2^{5/2}) = \frac{128}{5}\pi$$

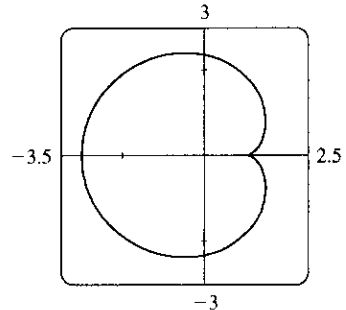

$$63. x = t + t^3, y = t - \frac{1}{t^2}, 1 \leq t \leq 2. \frac{dx}{dt} = 1 + 3t^2 \text{ and } \frac{dy}{dt} = 1 + \frac{2}{t^3}, \text{ so}$$

$$\left(\frac{dx}{dt}\right)^2 + \left(\frac{dy}{dt}\right)^2 = (1 + 3t^2)^2 + \left(1 + \frac{2}{t^3}\right)^2 \text{ and}$$

$$S = \int 2\pi y ds = \int_1^2 2\pi \left(t - \frac{1}{t^2}\right) \sqrt{(1 + 3t^2)^2 + \left(1 + \frac{2}{t^3}\right)^2} dt \approx 59.101.$$

$$64. S = \int_{\pi/4}^{\pi/2} 2\pi \cdot 2a \sin^2 \theta \sqrt{\csc^4 \theta + \sin^2 2\theta} d\theta = 4\pi a \int_{\pi/4}^{\pi/2} \sin^2 \theta \sqrt{\csc^4 \theta + \sin^2 2\theta} d\theta.$$

Using Simpson's Rule with  $n = 4$ ,  $\Delta\theta = \frac{\pi/2 - \pi/4}{4} = \frac{\pi}{16}$ , and  $f(\theta) = \sin^2 \theta \sqrt{\csc^4 \theta + \sin^2 2\theta}$ , we get

$$S \approx (4\pi a) \frac{\pi}{16 \cdot 3} \left[ f\left(\frac{\pi}{4}\right) + 4f\left(\frac{5\pi}{16}\right) + 2f\left(\frac{3\pi}{8}\right) + 4f\left(\frac{7\pi}{16}\right) + f\left(\frac{\pi}{2}\right) \right] \approx 11.0893a.$$

$$65. x = 3t^2, y = 2t^3, 0 \leq t \leq 5 \Rightarrow \left(\frac{dx}{dt}\right)^2 + \left(\frac{dy}{dt}\right)^2 = (6t)^2 + (6t^2)^2 = 36t^2(1 + t^2) \Rightarrow$$

$$S = \int_0^5 2\pi x \sqrt{(dx/dt)^2 + (dy/dt)^2} dt = \int_0^5 2\pi(3t^2)6t \sqrt{1 + t^2} dt = 18\pi \int_0^5 t^2 \sqrt{1 + t^2} 2t dt$$

$$= 18\pi \int_1^{26} (u - 1) \sqrt{u} du \quad [\text{where } u = 1 + t^2, du = 2t dt] = 18\pi \int_1^{26} (u^{3/2} - u^{1/2}) du$$

$$= 18\pi \left[ \frac{2}{5}u^{5/2} - \frac{2}{3}u^{3/2} \right]_1^{26} = 18\pi \left[ \left( \frac{2}{5} \cdot 676 \sqrt{26} - \frac{2}{3} \cdot 26 \sqrt{26} \right) - \left( \frac{2}{5} - \frac{2}{3} \right) \right]$$

$$= \frac{24}{5}\pi (949 \sqrt{26} + 1)$$

$$66. x = e^t - t, y = 4e^{t/2}, 0 \leq t \leq 1. \left(\frac{dx}{dt}\right)^2 + \left(\frac{dy}{dt}\right)^2 = (e^t - 1)^2 + (2e^{t/2})^2 = e^{2t} + 2e^t + 1 = (e^t + 1)^2.$$

$$S = \int_0^1 2\pi(e^t - t) \sqrt{(e^t - 1)^2 + (2e^{t/2})^2} dt = \int_0^1 2\pi(e^t - t)(e^t + 1) dt$$

$$= 2\pi \left[ \frac{1}{2}e^{2t} + e^t - (t-1)e^t - \frac{1}{2}t^2 \right]_0^1 = \pi(e^2 + 2e - 6)$$

67. If  $f'$  is continuous and  $f'(t) \neq 0$  for  $a \leq t \leq b$ , then either  $f'(t) > 0$  for all  $t$  in  $[a, b]$  or  $f'(t) < 0$  for all  $t$  in  $[a, b]$ . Thus,  $f$  is monotonic (in fact, strictly increasing or strictly decreasing) on  $[a, b]$ . It follows that  $f$  has an inverse. Set  $F = g \circ f^{-1}$ , that is, define  $F$  by  $F(x) = g(f^{-1}(x))$ . Then  $x = f(t) \Rightarrow f^{-1}(x) = t$ , so  $y = g(t) = g(f^{-1}(x)) = F(x)$ .

68. By Formula 9.2.5 with  $y = F(x)$ ,  $S = \int_a^b 2\pi F(x) \sqrt{1 + [F'(x)]^2} dx$ . But by Formula 11.2.2,

$$1 + [F'(x)]^2 = 1 + \left(\frac{dy}{dx}\right)^2 = 1 + \left(\frac{dy/dt}{dx/dt}\right)^2 = \frac{(dx/dt)^2 + (dy/dt)^2}{(dx/dt)^2}.$$

Using the Substitution Rule with  $x = x(t)$ , where  $a = x(\alpha)$  and  $b = x(\beta)$ , we have (since  $dx = \frac{dx}{dt} dt$ )

$$S = \int_{\alpha}^{\beta} 2\pi F(x(t)) \sqrt{\frac{(dx/dt)^2 + (dy/dt)^2}{(dx/dt)^2}} \frac{dx}{dt} dt = \int_{\alpha}^{\beta} 2\pi y \sqrt{\left(\frac{dx}{dt}\right)^2 + \left(\frac{dy}{dt}\right)^2} dt$$

which is Formula 11.2.7.

$$69. (a) \phi = \tan^{-1}\left(\frac{dy}{dx}\right) \Rightarrow \frac{d\phi}{dt} = \frac{d}{dt} \tan^{-1}\left(\frac{dy}{dx}\right) = \frac{1}{1 + (dy/dx)^2} \left[ \frac{d}{dt} \left(\frac{dy}{dx}\right) \right]. \text{ But } \frac{dy}{dx} = \frac{dy/dt}{dx/dt} = \frac{\dot{y}}{\dot{x}} \Rightarrow$$

$$\frac{d}{dt} \left(\frac{dy}{dx}\right) = \frac{d}{dt} \left(\frac{\dot{y}}{\dot{x}}\right) = \frac{\ddot{y}\dot{x} - \dot{y}\ddot{x}}{\dot{x}^2} \Rightarrow \frac{d\phi}{dt} = \frac{1}{1 + (\dot{y}/\dot{x})^2} \left(\frac{\ddot{y}\dot{x} - \dot{y}\ddot{x}}{\dot{x}^2}\right) = \frac{\dot{x}\ddot{y} - \dot{y}\ddot{x}}{\dot{x}^2 + \dot{y}^2}.$$

Using the Chain Rule, and the fact that  $s = \int_0^t \sqrt{\left(\frac{dx}{dt}\right)^2 + \left(\frac{dy}{dt}\right)^2} dt \Rightarrow$

$$\frac{ds}{dt} = \sqrt{\left(\frac{dx}{dt}\right)^2 + \left(\frac{dy}{dt}\right)^2} = (\dot{x}^2 + \dot{y}^2)^{1/2}, \text{ we have that}$$

$$\frac{d\phi}{ds} = \frac{d\phi/dt}{ds/dt} = \frac{(\dot{x}\ddot{y} - \dot{y}\ddot{x})}{(\dot{x}^2 + \dot{y}^2)^{1/2}} \cdot \frac{1}{(\dot{x}^2 + \dot{y}^2)^{1/2}} = \frac{\dot{x}\ddot{y} - \dot{y}\ddot{x}}{(\dot{x}^2 + \dot{y}^2)^{3/2}}. \text{ So}$$

$$\kappa = \left| \frac{d\phi}{ds} \right| = \left| \frac{\dot{x}\ddot{y} - \dot{y}\ddot{x}}{(\dot{x}^2 + \dot{y}^2)^{3/2}} \right| = \frac{|\dot{x}\ddot{y} - \dot{y}\ddot{x}|}{(\dot{x}^2 + \dot{y}^2)^{3/2}}.$$

$$(b) x = x \text{ and } y = f(x) \Rightarrow \dot{x} = 1, \ddot{x} = 0 \text{ and } \dot{y} = \frac{dy}{dx}, \ddot{y} = \frac{d^2y}{dx^2}.$$

$$\text{So } \kappa = \frac{|1 \cdot (d^2y/dx^2) - 0 \cdot (dy/dx)|}{[1 + (dy/dx)^2]^{3/2}} = \frac{|d^2y/dx^2|}{[1 + (dy/dx)^2]^{3/2}}.$$

$$70. (a) y = x^2 \Rightarrow \frac{dy}{dx} = 2x \Rightarrow \frac{d^2y}{dx^2} = 2. \text{ So } \kappa = \frac{|d^2y/dx^2|}{[1 + (dy/dx)^2]^{3/2}} = \frac{2}{(1 + 4x^2)^{3/2}}, \text{ and at } (1, 1),$$

$$\kappa = \frac{2}{5^{3/2}} = \frac{2}{5\sqrt{5}}.$$

(b)  $\kappa' = \frac{d\kappa}{dx} = -3(1 + 4x^2)^{-5/2}(8x) = 0 \Leftrightarrow x = 0 \Rightarrow y = 0$ . This is a maximum since  $\kappa' > 0$  for  $x < 0$  and  $\kappa' < 0$  for  $x > 0$ . So the parabola  $y = x^2$  has maximum curvature at the origin.

71.  $x = \theta - \sin \theta \Rightarrow \dot{x} = 1 - \cos \theta \Rightarrow \ddot{x} = \sin \theta$ , and  $y = 1 - \cos \theta \Rightarrow \dot{y} = \sin \theta \Rightarrow \ddot{y} = \cos \theta$ .

Therefore,  $\kappa = \frac{|\cos \theta - \cos^2 \theta - \sin^2 \theta|}{[(1 - \cos \theta)^2 + \sin^2 \theta]^{3/2}} = \frac{|\cos \theta - (\cos^2 \theta + \sin^2 \theta)|}{(1 - 2 \cos \theta + \cos^2 \theta + \sin^2 \theta)^{3/2}} = \frac{|\cos \theta - 1|}{(2 - 2 \cos \theta)^{3/2}}$ . The top of the arch is characterized by a horizontal tangent, and from Example 2(b) in Section 11.2, the tangent is horizontal when  $\theta = (2n - 1)\pi$ , so take  $n = 1$  and substitute  $\theta = \pi$  into the expression for  $\kappa$ :

$$\kappa = \frac{|\cos \pi - 1|}{(2 - 2 \cos \pi)^{3/2}} = \frac{|-1 - 1|}{[2 - 2(-1)]^{3/2}} = \frac{1}{4}.$$

72. (a) Every straight line has parametrizations of the form  $x = a + vt$ ,  $y = b + wt$ , where  $a, b$  are arbitrary and  $v, w \neq 0$ . For example, a straight line passing through distinct points  $(a, b)$  and  $(c, d)$  can be described as the parametrized curve  $x = a + (c - a)t$ ,  $y = b + (d - b)t$ . Starting with  $x = a + vt$ ,  $y = b + wt$ , we compute  $\dot{x} = v$ ,  $\dot{y} = w$ ,  $\ddot{x} = \ddot{y} = 0$ , and  $\kappa = \frac{|v \cdot 0 - w \cdot 0|}{(v^2 + w^2)^{3/2}} = 0$ .

(b) Parametric equations for a circle of radius  $r$  are  $x = r \cos \theta$  and  $y = r \sin \theta$ . We can take the center to be the origin. So  $\dot{x} = -r \sin \theta \Rightarrow \ddot{x} = -r \cos \theta$  and  $\dot{y} = r \cos \theta \Rightarrow \ddot{y} = -r \sin \theta$ . Therefore,

$$\kappa = \frac{|r^2 \sin^2 \theta + r^2 \cos^2 \theta|}{(r^2 \sin^2 \theta + r^2 \cos^2 \theta)^{3/2}} = \frac{r^2}{r^3} = \frac{1}{r}. \text{ And so for any } \theta \text{ (and thus any point), } \kappa = \frac{1}{r}.$$

73. The coordinates of  $T$  are  $(r \cos \theta, r \sin \theta)$ . Since  $TP$  was unwound from arc  $TA$ ,  $TP$  has length  $r\theta$ . Also  $\angle PTQ = \angle PTR - \angle QTR = \frac{1}{2}\pi - \theta$ , so  $P$  has coordinates  $x = r \cos \theta + r\theta \cos(\frac{1}{2}\pi - \theta) = r(\cos \theta + \theta \sin \theta)$ ,  $y = r \sin \theta - r\theta \sin(\frac{1}{2}\pi - \theta) = r(\sin \theta - \theta \cos \theta)$ .

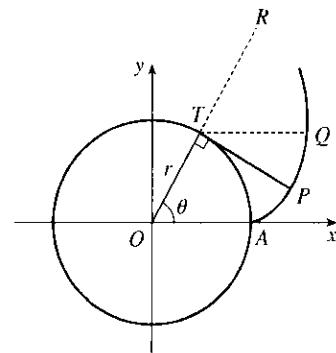

74. If the cow walks with the rope taut, it traces out the portion of the involute in Exercise 73 corresponding to the range  $0 \leq \theta \leq \pi$ , arriving at the point  $(-r, \pi r)$  when  $\theta = \pi$ . With the rope now fully extended, the cow walks in a semicircle of radius  $\pi r$ , arriving at  $(-r, -\pi r)$ . Finally, the cow traces out another portion of the involute, namely the reflection about the  $x$ -axis of the initial involute path. (This corresponds to the range  $-\pi \leq \theta \leq 0$ .)

Referring to the figure, we see that the total grazing area is  $2(A_1 + A_3)$ .  $A_3$  is one-quarter of the area of a circle of radius  $\pi r$ , so  $A_3 = \frac{1}{4}\pi(\pi r)^2 = \frac{1}{4}\pi^3 r^2$ . We will compute  $A_1 + A_2$  and then subtract  $A_2 = \frac{1}{2}\pi r^2$  to obtain  $A_1$ .

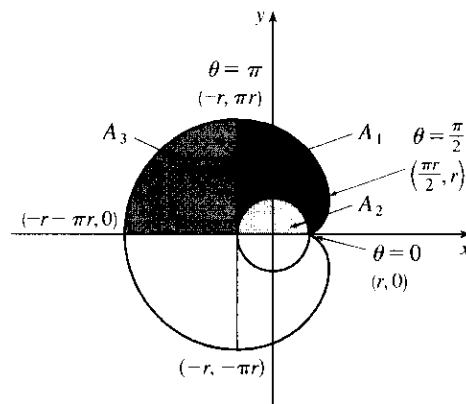

To find  $A_1 + A_2$ , first note that the rightmost point of the involute is  $(\frac{\pi}{2}r, r)$ . [To see this, note that  $dx/d\theta = 0$  when  $\theta = 0$  or  $\frac{\pi}{2}$ .  $\theta = 0$  corresponds to the cusp at  $(r, 0)$  and  $\theta = \frac{\pi}{2}$  corresponds to  $(\frac{\pi}{2}r, r)$ .] The leftmost point of the involute is  $(-r, \pi r)$ . Thus,  $A_1 + A_2 = \int_{\theta=-\pi}^{\pi/2} y dx - \int_{\theta=0}^{\pi/2} y dx = \int_{\theta=-\pi}^0 y dx$ . Now  $y dx = r(\sin \theta - \theta \cos \theta)r\theta \cos \theta d\theta = r^2(\theta \sin \theta \cos \theta - \theta^2 \cos^2 \theta)d\theta$ . Integrate:  $(1/r^2) \int y dx = -\theta \cos^2 \theta - \frac{1}{2}(\theta^2 - 1) \sin \theta \cos \theta - \frac{1}{6}\theta^3 + \frac{1}{2}\theta + C$ . This enables us to compute

$$A_1 + A_2 = r^2 \left[ -\theta \cos^2 \theta - \frac{1}{2}(\theta^2 - 1) \sin \theta \cos \theta - \frac{1}{6}\theta^3 + \frac{1}{2}\theta \right]_{\pi}^0 = r^2 \left[ 0 - \left( -\pi - \frac{\pi^3}{6} + \frac{\pi}{2} \right) \right] = r^2 \left( \frac{\pi}{2} + \frac{\pi^3}{6} \right)$$

Therefore,  $A_1 = (A_1 + A_2) - A_2 = \frac{1}{6}\pi^3 r^2$ , so the grazing area is  $2(A_1 + A_3) = 2(\frac{1}{6}\pi^3 r^2 + \frac{1}{4}\pi^3 r^2) = \frac{5}{6}\pi^3 r^2$ .

## LABORATORY PROJECT Bezier Curves

1. The parametric equations for a cubic Bézier curve are

$$x = x_0(1-t)^3 + 3x_1t(1-t)^2 + 3x_2t^2(1-t) + x_3t^3$$

$$y = y_0(1-t)^3 + 3y_1t(1-t)^2 + 3y_2t^2(1-t) + y_3t^3$$

where  $0 \leq t \leq 1$ . We are given the points  $P_0(x_0, y_0) = (4, 1)$ ,  $P_1(x_1, y_1) = (28, 48)$ ,  $P_2(x_2, y_2) = (50, 42)$ , and  $P_3(x_3, y_3) = (40, 5)$ . The curve is then given by

$$x(t) = 4(1-t)^3 + 3 \cdot 28t(1-t)^2 + 3 \cdot 50t^2(1-t) + 40t^3$$

$$y(t) = 1(1-t)^3 + 3 \cdot 48t(1-t)^2 + 3 \cdot 42t^2(1-t) + 5t^3$$

where  $0 \leq t \leq 1$ . The line segments are of the form  $x = x_0 + (x_1 - x_0)t$ ,  $y = y_0 + (y_1 - y_0)t$ :

$P_0P_1$	$x = 4 + 24t,$	$y = 1 + 47t$
$P_1P_2$	$x = 28 + 22t,$	$y = 48 - 6t$
$P_2P_3$	$x = 50 - 10t,$	$y = 42 - 37t$

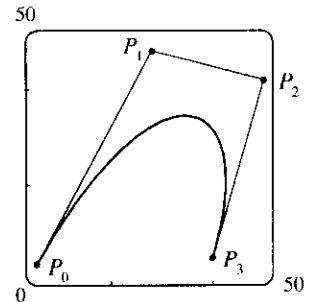

2. It suffices to show that the slope of the tangent at  $P_0$  is the same as that of line segment  $P_0P_1$ , namely  $\frac{y_1 - y_0}{x_1 - x_0}$ . We calculate the slope of the tangent to the Bézier curve:

$$\frac{dy/dt}{dx/dt} = \frac{-3y_0(1-t)^2 + 3y_1[-2t(1-t) + (1-t)^2] + 3y_2[-t^2 + (2t)(1-t)] + 3y_3t^2}{-3x_0^2(1-t) + 3x_1[-2t(1-t) + (1-t)^2] + 3x_2[-t^2 + (2t)(1-t)] + 3x_3t^2}$$

At point  $P_0$ ,  $t = 0$ , so the slope of the tangent is  $\frac{-3y_0 + 3y_1}{-3x_0 + 3x_1} = \frac{y_1 - y_0}{x_1 - x_0}$ . So the tangent to the curve at  $P_0$  passes through  $P_1$ . Similarly, the slope of the tangent at point  $P_3$  (where  $t = 1$ ) is  $\frac{-3y_2 + 3y_3}{-3x_2 + 3x_3} = \frac{y_3 - y_2}{x_3 - x_2}$ , which is also the slope of line  $P_2P_3$ .

3. It seems that if  $P_1$  were to the right of  $P_2$ , a loop would appear. We try setting  $P_1 = (110, 30)$ , and the resulting curve does indeed have a loop.

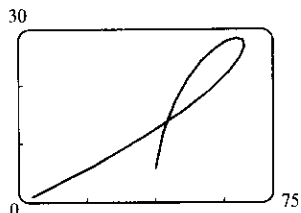

4. Based on the behavior of the Bézier curve in Problems 1–3, we suspect that the four control points should be in an exaggerated C shape. We try  $P_0(10, 12)$ ,  $P_1(4, 15)$ ,  $P_2(4, 5)$ , and  $P_3(10, 8)$ , and these produce a decent C. If you are using a CAS, it may be necessary to instruct it to make the  $x$ - and  $y$ -scales the same so as not to distort the figure (this is called a “constrained projection” in Maple.)

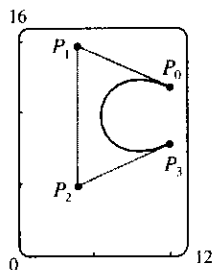

5. We use the same  $P_0$  and  $P_1$  as in Problem 4, and use part of our C as the top of an S. To prevent the center line from slanting up too much, we move  $P_2$  up to  $(4, 6)$  and  $P_3$  down and to the left, to  $(8, 7)$ . In order to have a smooth joint between the top and bottom halves of the S (and a symmetric S), we determine points  $P_4$ ,  $P_5$ , and  $P_6$  by rotating points  $P_2$ ,  $P_1$ , and  $P_0$  about the center of the letter (point  $P_3$ ). The points are therefore  $P_4(12, 8)$ ,  $P_5(12, -1)$ , and  $P_6(6, 2)$ .

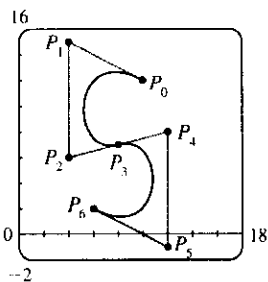

## 11.3 Polar Coordinates

1. (a) By adding
- $2\pi$
- to
- $\frac{\pi}{2}$
- , we obtain the (b)
- $(-2, \frac{\pi}{4})$

point  $(1, \frac{5\pi}{2})$ . The direction opposite  $\frac{\pi}{2}$  is  $\frac{3\pi}{2}$ , so  $(-1, \frac{3\pi}{2})$  is a point that satisfies the  $r < 0$  requirement.

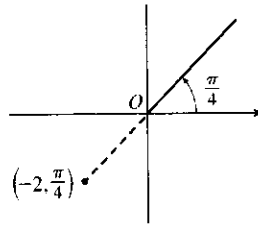
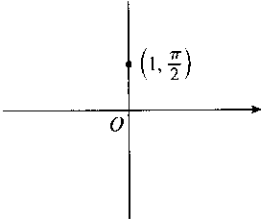

$$(2, \frac{5\pi}{4}), (-2, \frac{9\pi}{4})$$

- (c)
- $(3, 2)$

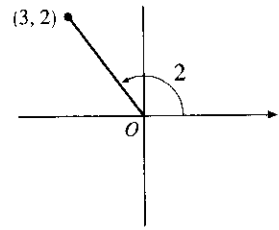

$$(3, 2 + 2\pi), (-3, 2 + \pi)$$

2. (a)
- $(3, 0)$

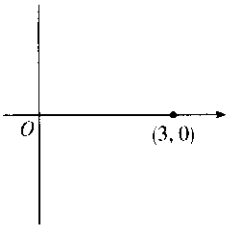

$$(3, 2\pi), (-3, \pi)$$

- (b)
- $(2, -\frac{\pi}{7})$

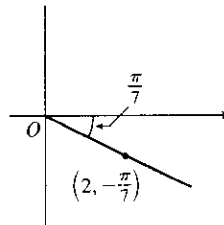

$$(2, \frac{13\pi}{7}), (-2, \frac{6\pi}{7})$$

- (c)
- $(-1, -\frac{\pi}{2})$

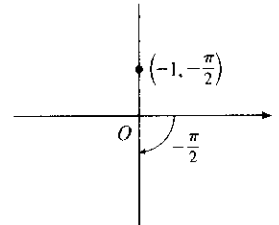

$$(1, \frac{\pi}{2}), (-1, \frac{3\pi}{2})$$

3. (a)

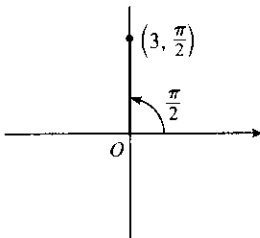

$x = 3 \cos \frac{\pi}{2} = 3(0) = 0$  and  
 $y = 3 \sin \frac{\pi}{2} = 3(1) = 3$  give us  
 the Cartesian coordinates  $(0, 3)$ .

- (b)

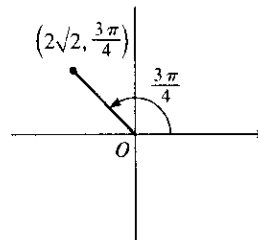

$$\begin{aligned} x &= 2\sqrt{2} \cos \frac{3\pi}{4} \\ &= 2\sqrt{2} \left(-\frac{1}{\sqrt{2}}\right) = -2 \text{ and} \\ y &= 2\sqrt{2} \sin \frac{3\pi}{4} = 2\sqrt{2} \left(\frac{1}{\sqrt{2}}\right) = 2 \\ &\text{give us } (-2, 2). \end{aligned}$$

- (c)

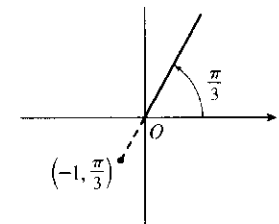

$$\begin{aligned} x &= -1 \cos \frac{\pi}{3} = -\frac{1}{2} \text{ and} \\ y &= -1 \sin \frac{\pi}{3} = -\frac{\sqrt{3}}{2} \text{ give} \\ &\text{us } \left(-\frac{1}{2}, -\frac{\sqrt{3}}{2}\right). \end{aligned}$$



4. (a)

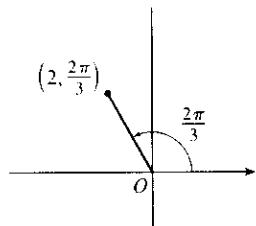

$$x = 2 \cos \frac{2\pi}{3} = -1 \text{ and}$$

$$y = 2 \sin \frac{2\pi}{3} = \sqrt{3} \text{ give}$$

us  $(-1, \sqrt{3})$ .

(b)

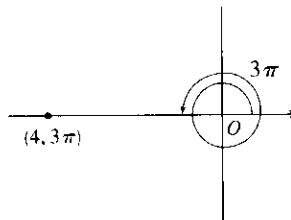

$$x = 4 \cos 3\pi = -4 \text{ and}$$

$$y = 4 \sin 3\pi = 0 \text{ give}$$

us  $(-4, 0)$ .

(c)

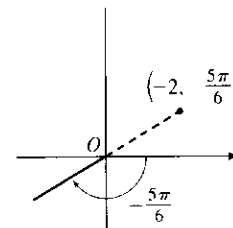

$$x = -2 \cos\left(-\frac{5\pi}{6}\right) = \sqrt{3}$$

$$\text{and } y = -2 \sin\left(-\frac{5\pi}{6}\right) = 1$$

give us  $(\sqrt{3}, 1)$ .

5. (a)  $x = 1$  and  $y = 1 \Rightarrow r = \sqrt{1^2 + 1^2} = \sqrt{2}$  and  $\theta = \tan^{-1}\left(\frac{1}{1}\right) = \frac{\pi}{4}$ . Since  $(1, 1)$  is in the first quadrant, the polar coordinates are (i)  $(\sqrt{2}, \frac{\pi}{4})$  and (ii)  $(-\sqrt{2}, \frac{5\pi}{4})$ .

(b)  $x = 2\sqrt{3}$  and  $y = -2 \Rightarrow r = \sqrt{(2\sqrt{3})^2 + (-2)^2} = \sqrt{12 + 4} = \sqrt{16} = 4$  and

$$\theta = \tan^{-1}\left(-\frac{2}{2\sqrt{3}}\right) = \tan^{-1}\left(-\frac{1}{\sqrt{3}}\right) = -\frac{\pi}{6}$$

Since  $(2\sqrt{3}, -2)$  is in the fourth quadrant and  $0 \leq \theta \leq 2\pi$ , the polar coordinates are (i)  $(4, \frac{11\pi}{6})$  and (ii)  $(-4, \frac{5\pi}{6})$ .

6. (a)  $(x, y) = (-1, -\sqrt{3})$ ,  $r = \sqrt{1 + 3} = 2$ ,  $\tan \theta = y/x = \sqrt{3}$  and  $(x, y)$  is in the third quadrant, so  $\theta = \frac{4\pi}{3}$ . The polar coordinates are (i)  $(2, \frac{4\pi}{3})$  and (ii)  $(-2, \frac{\pi}{3})$ .

(b)  $(x, y) = (-2, 3)$ ,  $r = \sqrt{4 + 9} = \sqrt{13}$ ,  $\tan \theta = y/x = -\frac{3}{2}$  and  $(x, y)$  is in the second quadrant, so

$$\theta = \tan^{-1}\left(-\frac{3}{2}\right) + \pi$$

The polar coordinates are (i)  $(\sqrt{13}, \theta)$  and (ii)  $(-\sqrt{13}, \theta + \pi)$ .

7. The curves  $r = 1$  and  $r = 2$  represent circles with center  $O$  and radii 1 and 2. The region in the plane satisfying  $1 \leq r \leq 2$  consists of both circles and the shaded region between them in the figure.

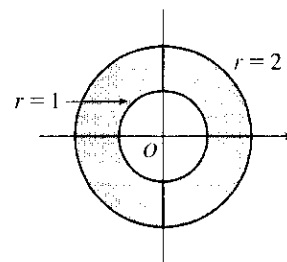

8.  $r \geq 0$ ,  $\pi/3 \leq \theta \leq 2\pi/3$

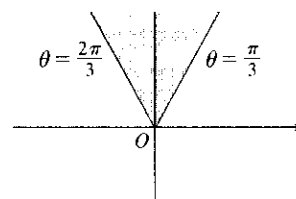

9. The region satisfying  $0 \leq r < 4$  and  $-\pi/2 \leq \theta < \pi/6$  does not include the circle  $r = 4$  nor the line  $\theta = \pi/6$ .

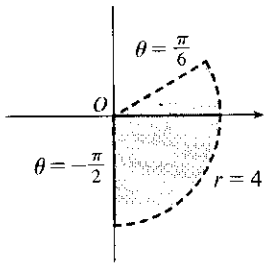

10.  $2 < r \leq 5$ ,  $3\pi/4 < \theta < 5\pi/4$

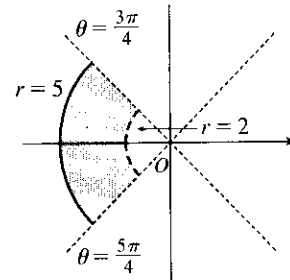

11.  $2 < r < 3$ ,  $\frac{5\pi}{3} \leq \theta \leq \frac{7\pi}{3}$

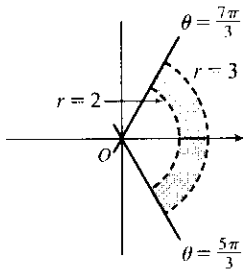

12.  $-1 \leq r \leq 1$ ,  $\frac{\pi}{4} \leq \theta \leq \frac{3\pi}{4}$

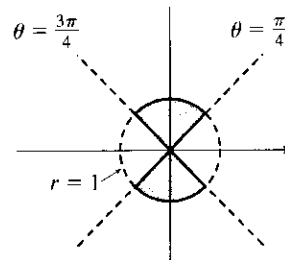

13.  $(r, \theta) = (1, \frac{\pi}{6}) \Rightarrow x = 1 \cos \frac{\pi}{6} = \frac{\sqrt{3}}{2}$  and  $y = 1 \sin \frac{\pi}{6} = \frac{1}{2}$ .

$(r, \theta) = (3, \frac{3\pi}{4}) \Rightarrow x = 3 \cos \frac{3\pi}{4} = -\frac{3\sqrt{2}}{2}$  and  $y = 3 \sin \frac{3\pi}{4} = \frac{3\sqrt{2}}{2}$ . The distance between them is

$$\begin{aligned} \sqrt{\left[\frac{\sqrt{3}}{2} - \left(-\frac{3\sqrt{2}}{2}\right)\right]^2 + \left(\frac{1}{2} - \frac{3\sqrt{2}}{2}\right)^2} &= \sqrt{\frac{1}{4}(\sqrt{3} + 3\sqrt{2})^2 + \frac{1}{4}(1 - 3\sqrt{2})^2} \\ &= \sqrt{\frac{1}{4}\sqrt{(3 + 6\sqrt{6} + 18) + (1 - 6\sqrt{2} + 18)}} = \frac{1}{2}\sqrt{40 + 6\sqrt{6} - 6\sqrt{2}} \end{aligned}$$

14. The points  $(r_1, \theta_1)$  and  $(r_2, \theta_2)$  in Cartesian coordinates are  $(r_1 \cos \theta_1, r_1 \sin \theta_1)$  and  $(r_2 \cos \theta_2, r_2 \sin \theta_2)$ , respectively. The square of the distance between them is

$$\begin{aligned} &(r_2 \cos \theta_2 - r_1 \cos \theta_1)^2 + (r_2 \sin \theta_2 - r_1 \sin \theta_1)^2 \\ &= (r_2^2 \cos^2 \theta_2 - 2r_1 r_2 \cos \theta_1 \cos \theta_2 + r_1^2 \cos^2 \theta_1) + (r_2^2 \sin^2 \theta_2 - 2r_1 r_2 \sin \theta_1 \sin \theta_2 + r_1^2 \sin^2 \theta_1) \\ &= r_1^2 (\sin^2 \theta_1 + \cos^2 \theta_1) + r_2^2 (\sin^2 \theta_2 + \cos^2 \theta_2) - 2r_1 r_2 (\cos \theta_1 \cos \theta_2 + \sin \theta_1 \sin \theta_2) \\ &= r_1^2 - 2r_1 r_2 \cos(\theta_1 - \theta_2) + r_2^2, \end{aligned}$$

so the distance between them is  $\sqrt{r_1^2 - 2r_1 r_2 \cos(\theta_1 - \theta_2) + r_2^2}$ .

15.  $r = 2 \Leftrightarrow \sqrt{x^2 + y^2} = 2 \Leftrightarrow x^2 + y^2 = 4$ , a circle of radius 2 centered at the origin.

16.  $r \cos \theta = 1 \Leftrightarrow x = 1$ , a vertical line.

17.  $r = 3 \sin \theta \Rightarrow r^2 = 3r \sin \theta \Leftrightarrow x^2 + y^2 = 3y \Leftrightarrow x^2 + (y - \frac{3}{2})^2 = (\frac{3}{2})^2$ , a circle of radius  $\frac{3}{2}$  centered at  $(0, \frac{3}{2})$ . The first two equations are actually equivalent since  $r^2 = 3r \sin \theta \Rightarrow r(r - 3 \sin \theta) = 0 \Rightarrow r = 0$  or  $r = 3 \sin \theta$ . But  $r = 3 \sin \theta$  gives the point  $r = 0$  (the pole) when  $\theta = 0$ . Thus, the single equation  $r = 3 \sin \theta$  is equivalent to the compound condition ( $r = 0$  or  $r = 3 \sin \theta$ ).

18.  $r = 2 \sin \theta + 2 \cos \theta \Rightarrow r^2 = 2r \sin \theta + 2r \cos \theta \Leftrightarrow x^2 + y^2 = 2y + 2x \Leftrightarrow (x^2 - 2x + 1) + (y^2 - 2y + 1) = 2 \Leftrightarrow (x - 1)^2 + (y - 1)^2 = 2$ . The first implication is reversible since  $r^2 = 2r \sin \theta + 2r \cos \theta \Rightarrow r = 0$  or  $r = 2 \sin \theta + 2 \cos \theta$ , but the curve  $r = 2 \sin \theta + 2 \cos \theta$  passes through the pole ( $r = 0$ ) when  $\theta = -\frac{\pi}{4}$ , so  $r = 2 \sin \theta + 2 \cos \theta$  includes the single point of  $r = 0$ . The curve is a circle of radius  $\sqrt{2}$ , centered at  $(1, 1)$ .
19.  $r = \csc \theta \Leftrightarrow r = \frac{1}{\sin \theta} \Leftrightarrow r \sin \theta = 1 \Leftrightarrow y = 1$ , a horizontal line 1 unit above the  $x$ -axis.
20.  $r = \tan \theta \sec \theta = \frac{\sin \theta}{\cos^2 \theta} \Rightarrow r \cos^2 \theta = \sin \theta \Leftrightarrow (r \cos \theta)^2 = r \sin \theta \Leftrightarrow x^2 = y$ , a parabola with vertex at the origin opening upward. The first implication is reversible since  $\cos \theta = 0$  would imply  $\sin \theta = r \cos^2 \theta = 0$ , contradicting the fact that  $\cos^2 \theta + \sin^2 \theta = 1$ .
21.  $x = 3 \Leftrightarrow r \cos \theta = 3 \Leftrightarrow r = 3/\cos \theta \Leftrightarrow r = 3 \sec \theta$ .
22.  $x^2 + y^2 = 9 \Leftrightarrow r^2 = 9 \Leftrightarrow r = 3$ . [ $r = -3$  gives the same curve.]
23.  $x = -y^2 \Leftrightarrow r \cos \theta = -r^2 \sin^2 \theta \Leftrightarrow \cos \theta = -r \sin^2 \theta \Leftrightarrow r = -\frac{\cos \theta}{\sin^2 \theta} = -\cot \theta \csc \theta$ .
24.  $x + y = 9 \Leftrightarrow r \cos \theta + r \sin \theta = 9 \Leftrightarrow r = 9/(\cos \theta + \sin \theta)$ .
25.  $x^2 + y^2 = 2cx \Leftrightarrow r^2 = 2cr \cos \theta \Leftrightarrow r^2 - 2cr \cos \theta = 0 \Leftrightarrow r(r - 2c \cos \theta) = 0 \Leftrightarrow r = 0$  or  $r = 2c \cos \theta$ .  $r = 0$  is included in  $r = 2c \cos \theta$  when  $\theta = \frac{\pi}{2} + n\pi$ , so the curve is represented by the single equation  $r = 2c \cos \theta$ .
26.  $x^2 - y^2 = 1 \Leftrightarrow (r \cos \theta)^2 - (r \sin \theta)^2 = 1 \Leftrightarrow r^2(\cos^2 \theta - \sin^2 \theta) = 1 \Leftrightarrow r^2 \cos 2\theta = 1 \Rightarrow r^2 = \sec 2\theta$
27. (a) The description leads immediately to the polar equation  $\theta = \frac{\pi}{6}$ , and the Cartesian equation  $\tan \theta = y/x \Rightarrow y = (\tan \frac{\pi}{6})x = \frac{1}{\sqrt{3}}x$  is slightly more difficult to derive.  
(b) The easier description here is the Cartesian equation  $x = 3$ .
28. (a) Because its center is not at the origin, it is more easily described by its Cartesian equation,  $(x - 2)^2 + (y - 3)^2 = 5^2$ .  
(b) This circle is more easily given in polar coordinates:  $r = 4$ . The Cartesian equation is also simple:  $x^2 + y^2 = 16$ .
29.  $\theta = -\pi/6$
30.  $r^2 - 3r + 2 = 0 \Leftrightarrow (r - 1)(r - 2) = 0 \Leftrightarrow r = 1$  or  $r = 2$

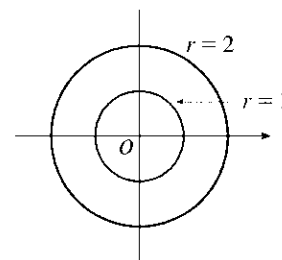
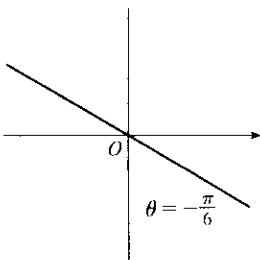



39.  $r = 2 \cos 4\theta$

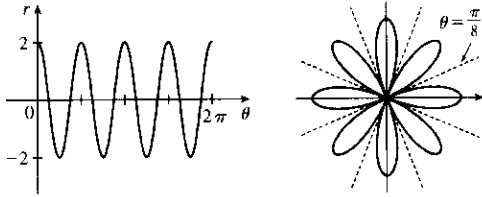

40.  $r = \sin 5\theta$

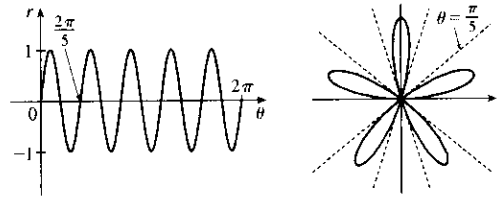

41.  $r^2 = 4 \cos 2\theta$

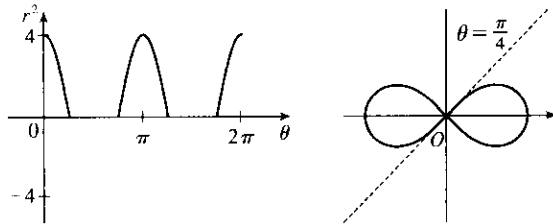

42.  $r^2 = \sin 2\theta$

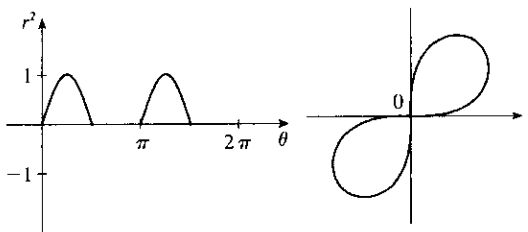

43.  $r = 2 \cos(\frac{3}{2}\theta)$

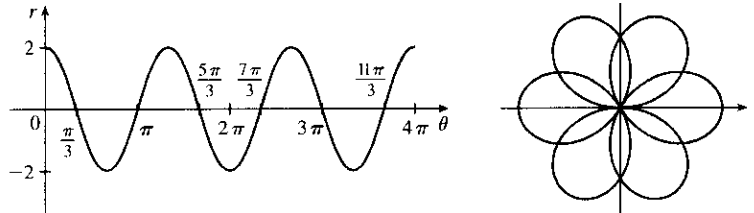

44.  $r^2\theta = 1 \Leftrightarrow r = \pm 1/\sqrt{\theta}$  for  $\theta > 0$

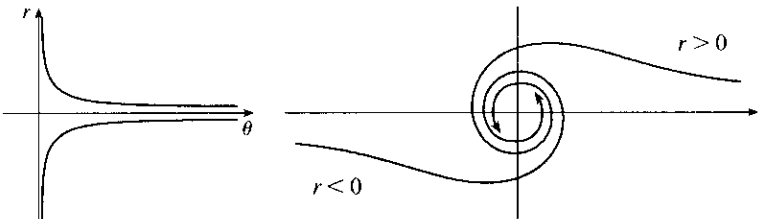

45.  $r = 1 + 2 \cos 2\theta$

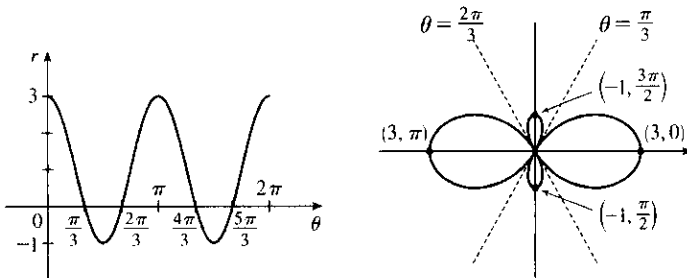

46.  $r = 1 + 2 \cos(\theta/2)$

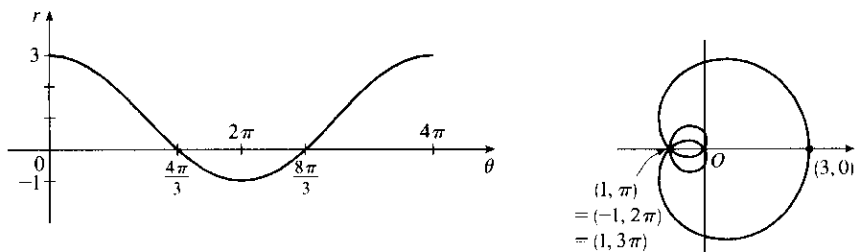

47. For  $\theta = 0, \pi,$  and  $2\pi,$   $r$  has its minimum value of about 0.5. For  $\theta = \frac{\pi}{2}$  and  $\frac{3\pi}{2},$   $r$  attains its maximum value of 2. We see that the graph has a similar shape for  $0 \leq \theta \leq \pi$  and  $\pi \leq \theta \leq 2\pi.$

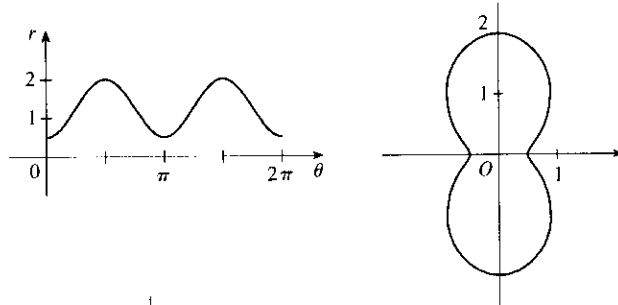

48.

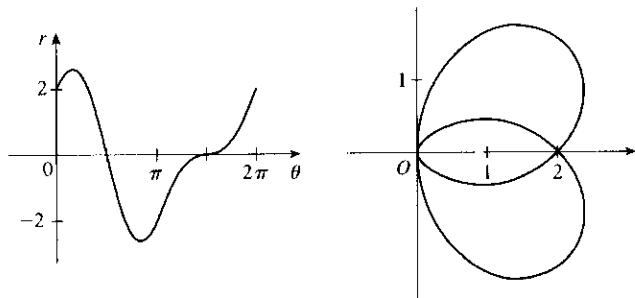

49.  $x = r \cos \theta = (4 + 2 \sec \theta) \cos \theta = 4 \cos \theta + 2.$  Now,  $r \rightarrow \infty \Rightarrow (4 + 2 \sec \theta) \rightarrow \infty \Rightarrow \theta \rightarrow (\frac{\pi}{2})^-$  or  $\theta \rightarrow (\frac{3\pi}{2})^+$  (since we need only consider  $0 \leq \theta < 2\pi,$  so  $\lim_{r \rightarrow \infty} x = \lim_{\theta \rightarrow \pi/2^-} (4 \cos \theta + 2) = 2.$  Also,  $r \rightarrow -\infty \Rightarrow (4 + 2 \sec \theta) \rightarrow -\infty \Rightarrow \theta \rightarrow (\frac{\pi}{2})^+$  or  $\theta \rightarrow (\frac{3\pi}{2})^-,$  so  $\lim_{r \rightarrow -\infty} x = \lim_{\theta \rightarrow \pi/2^+} (4 \cos \theta + 2) = 2.$  Therefore,  $\lim_{r \rightarrow \pm\infty} x = 2 \Rightarrow x = 2$  is a vertical asymptote.

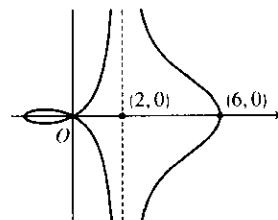

50.  $y = r \sin \theta = 2 \sin \theta - \csc \theta \sin \theta = 2 \sin \theta - 1.$   
 $r \rightarrow \infty \Rightarrow (2 - \csc \theta) \rightarrow \infty \Rightarrow \csc \theta \rightarrow -\infty \Rightarrow \theta \rightarrow \pi^+$  (since we need only consider  $0 \leq \theta < 2\pi$ ) and so  $\lim_{r \rightarrow \infty} y = \lim_{\theta \rightarrow \pi^+} 2 \sin \theta - 1 = -1.$  Also  $r \rightarrow -\infty \Rightarrow (2 - \csc \theta) \rightarrow -\infty \Rightarrow \csc \theta \rightarrow \infty \Rightarrow \theta \rightarrow \pi^-$  and so  $\lim_{r \rightarrow -\infty} y = \lim_{\theta \rightarrow \pi^-} 2 \sin \theta - 1 = -1.$  Therefore  $\lim_{r \rightarrow \pm\infty} y = -1 \Rightarrow y = -1$  is a horizontal asymptote.

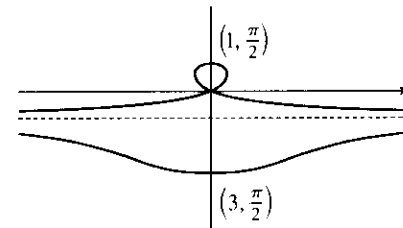
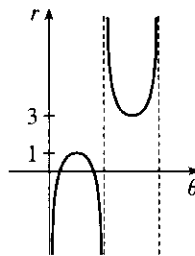

51. To show that  $x = 1$  is an asymptote we must prove  $\lim_{r \rightarrow \pm\infty} x = 1.$

$x = r \cos \theta = (\sin \theta \tan \theta) \cos \theta = \sin^2 \theta.$  Now,  $r \rightarrow \infty \Rightarrow \sin \theta \tan \theta \rightarrow \infty \Rightarrow \theta \rightarrow (\frac{\pi}{2})^-,$  so  $\lim_{r \rightarrow \infty} x = \lim_{\theta \rightarrow \pi/2^-} \sin^2 \theta = 1.$  Also,  $r \rightarrow -\infty \Rightarrow \sin \theta \tan \theta \rightarrow -\infty \Rightarrow \theta \rightarrow (\frac{\pi}{2})^+,$  so  $\lim_{r \rightarrow -\infty} x = \lim_{\theta \rightarrow \pi/2^+} \sin^2 \theta = 1.$

Therefore,  $\lim_{r \rightarrow \pm\infty} x = 1 \Rightarrow x = 1$  is a vertical asymptote. Also notice that  $x = \sin^2 \theta \geq 0$  for all  $\theta,$  and

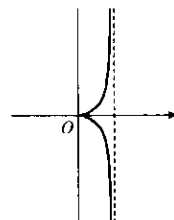

$x = \sin^2 \theta \leq 1$  for all  $\theta$ . And  $x \neq 1$ , since the curve is not defined at odd multiples of  $\frac{\pi}{2}$ . Therefore, the curve lies entirely within the vertical strip  $0 \leq x < 1$ .

52. The equation is  $(x^2 + y^2)^3 = 4x^2y^2$ , but using polar coordinates we know that

$x^2 + y^2 = r^2$  and  $x = r \cos \theta$  and  $y = r \sin \theta$ . Substituting into the given

$$\text{equation: } r^6 = 4r^2 \cos^2 \theta r^2 \sin^2 \theta \Rightarrow r^2 = 4 \cos^2 \theta \sin^2 \theta \Rightarrow$$

$$r = \pm 2 \cos \theta \sin \theta = \pm \sin 2\theta. \quad r = \pm \sin 2\theta \text{ is sketched at right.}$$

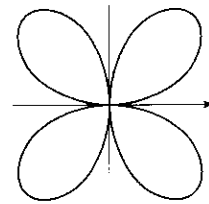

53. (a) We see that the curve crosses itself at the origin, where  $r = 0$  (in fact the inner loop corresponds to negative  $r$ -values), so we solve the equation of the limaçon for  $r = 0 \Leftrightarrow c \sin \theta = -1 \Leftrightarrow \sin \theta = -1/c$ . Now if  $|c| < 1$ , then this equation has no solution and hence there is no inner loop. But if  $c < -1$ , then on the interval  $(0, 2\pi)$  the equation has the two solutions  $\theta = \sin^{-1}(-1/c)$  and  $\theta = \pi - \sin^{-1}(-1/c)$ , and if  $c > 1$ , the solutions are  $\theta = \pi + \sin^{-1}(1/c)$  and  $\theta = 2\pi - \sin^{-1}(1/c)$ . In each case,  $r < 0$  for  $\theta$  between the two solutions, indicating a loop.
- (b) For  $0 < c < 1$ , the dimple (if it exists) is characterized by the fact that  $y$  has a local maximum at  $\theta = \frac{3\pi}{2}$ . So we determine for what  $c$ -values  $\frac{d^2y}{d\theta^2}$  is negative at  $\theta = \frac{3\pi}{2}$ , since by the Second Derivative Test this indicates a maximum:  $y = r \sin \theta = \sin \theta + c \sin^2 \theta \Rightarrow \frac{dy}{d\theta} = \cos \theta + 2c \sin \theta \cos \theta = \cos \theta + c \sin 2\theta \Rightarrow \frac{d^2y}{d\theta^2} = -\sin \theta + 2c \cos 2\theta$ . At  $\theta = \frac{3\pi}{2}$ , this is equal to  $-(-1) + 2c(-1) = 1 - 2c$ , which is negative only for  $c > \frac{1}{2}$ . A similar argument shows that for  $-1 < c < 0$ ,  $y$  only has a local minimum at  $\theta = \frac{\pi}{2}$  (indicating a dimple) for  $c < -\frac{1}{2}$ .
54. (a)  $r = \sin(\theta/2)$ . This equation must correspond to one of II, III or VI, since these are the only graphs which are bounded. In fact it must be VI, since this is the only graph which is completed after a rotation of exactly  $4\pi$ .
- (b)  $r = \sin(\theta/4)$ . This equation must correspond to III, since this is the only graph which is completed after a rotation of exactly  $8\pi$ .
- (c)  $r = \sec(3\theta)$ . This must correspond to IV, since the graph is unbounded at  $\theta = \frac{\pi}{6}, \frac{\pi}{2}, \frac{2\pi}{3}$ , and so on.
- (d)  $r = \theta \sin \theta$ . This must correspond to V. Note that  $r = 0$  whenever  $\theta$  is a multiple of  $\pi$ . This graph is unbounded, and each time  $\theta$  moves through an interval of  $2\pi$ , the same basic shape is repeated (because of the periodic  $\sin \theta$  factor) but it gets larger each time (since  $\theta$  increases each time we go around.)
- (e)  $r = 1 + 4 \cos 5\theta$ . This corresponds to II, since it is bounded, has fivefold rotational symmetry, and takes only one rotation through  $2\pi$  to be complete.
- (f)  $r = 1/\sqrt{\theta}$ . This corresponds to I, since it is unbounded at  $\theta = 0$ , and  $r$  decreases as  $\theta$  increases; in fact  $r \rightarrow 0$  as  $\theta \rightarrow \infty$ .

55.  $r = 2 \sin \theta \Rightarrow x = r \cos \theta = 2 \sin \theta \cos \theta = \sin 2\theta, y = r \sin \theta = 2 \sin^2 \theta \Rightarrow$

$$\frac{dy}{dx} = \frac{dy/d\theta}{dx/d\theta} = \frac{2 \cdot 2 \sin \theta \cos \theta}{\cos 2\theta \cdot 2} = \frac{\sin 2\theta}{\cos 2\theta} = \tan 2\theta$$

$$\text{When } \theta = \frac{\pi}{6}, \frac{dy}{dx} = \tan\left(2 \cdot \frac{\pi}{6}\right) = \tan \frac{\pi}{3} = \sqrt{3}.$$

$$56. r = 2 - \sin \theta \Rightarrow x = r \cos \theta = (2 - \sin \theta) \cos \theta, y = r \sin \theta = (2 - \sin \theta) \sin \theta \Rightarrow$$

$$\frac{dy}{dx} = \frac{dy/d\theta}{dx/d\theta} = \frac{(2 - \sin \theta) \cos \theta + \sin \theta(-\cos \theta)}{(2 - \sin \theta)(-\sin \theta) + \cos \theta(-\cos \theta)} = \frac{2 \cos \theta - 2 \sin \theta \cos \theta}{-2 \sin \theta + \sin^2 \theta - \cos^2 \theta} = \frac{2 \cos \theta - \sin 2\theta}{-2 \sin \theta - \cos 2\theta}$$

$$\text{When } \theta = \frac{\pi}{3}, \frac{dy}{dx} = \frac{2(1/2) - (\sqrt{3}/2)}{-2(\sqrt{3}/2) - (-1/2)} = \frac{1 - \sqrt{3}/2}{-\sqrt{3} + 1/2} \cdot \frac{2}{2} = \frac{2 - \sqrt{3}}{1 - 2\sqrt{3}}$$

$$57. r = 1/\theta \Rightarrow x = r \cos \theta = (\cos \theta)/\theta, y = r \sin \theta = (\sin \theta)/\theta \Rightarrow$$

$$\frac{dy}{dx} = \frac{dy/d\theta}{dx/d\theta} = \frac{\sin \theta(-1/\theta^2) + (1/\theta) \cos \theta}{\cos \theta(-1/\theta^2) - (1/\theta) \sin \theta} \cdot \frac{\theta^2}{\theta^2} = \frac{-\sin \theta + \theta \cos \theta}{-\cos \theta - \theta \sin \theta}$$

$$\text{When } \theta = \pi, \frac{dy}{dx} = \frac{-0 + \pi(-1)}{-(-1) - \pi(0)} = \frac{-\pi}{1} = -\pi.$$

$$58. r = \ln \theta \Rightarrow x = r \cos \theta = \ln \theta \cos \theta, y = r \sin \theta = \ln \theta \sin \theta \Rightarrow$$

$$\frac{dy}{dx} = \frac{dy/d\theta}{dx/d\theta} = \frac{\sin \theta(1/\theta) + \ln \theta \cos \theta}{\cos \theta(1/\theta) - \ln \theta \sin \theta} \cdot \frac{\theta}{\theta} = \frac{\sin \theta + \theta \ln \theta \cos \theta}{\cos \theta - \theta \ln \theta \sin \theta}$$

$$\text{When } \theta = e, \frac{dy}{dx} = \frac{\sin e + e \ln e \cos e}{\cos e - e \ln e \sin e} = \frac{\sin e + e \cos e}{\cos e - e \sin e}.$$

$$59. r = 1 + \cos \theta \Rightarrow x = r \cos \theta = \cos \theta + \cos^2 \theta, y = r \sin \theta = \sin \theta + \sin \theta \cos \theta \Rightarrow$$

$$\frac{dy}{dx} = \frac{dy/d\theta}{dx/d\theta} = \frac{\cos \theta + \cos^2 \theta - \sin^2 \theta}{-\sin \theta - 2 \cos \theta \sin \theta} = \frac{\cos \theta + \cos 2\theta}{-\sin \theta - \sin 2\theta}$$

$$\text{When } \theta = \frac{\pi}{6}, \frac{dy}{dx} = \frac{\frac{\sqrt{3}}{2} + \frac{1}{2}}{-\frac{1}{2} - \frac{\sqrt{3}}{2}} = \frac{\frac{\sqrt{3}}{2} + \frac{1}{2}}{-\left(\frac{1}{2} + \frac{\sqrt{3}}{2}\right)} = -1.$$

$$60. r = \sin 3\theta \Rightarrow x = r \cos \theta = \sin 3\theta \cos \theta, y = r \sin \theta = \sin 3\theta \sin \theta \Rightarrow$$

$$\frac{dy}{dx} = \frac{dy/d\theta}{dx/d\theta} = \frac{3 \cos 3\theta \sin \theta + \sin 3\theta \cos \theta}{3 \cos 3\theta \cos \theta - \sin 3\theta \sin \theta}$$

$$\text{When } \theta = \frac{\pi}{6}, \frac{dy}{dx} = \frac{3(0)(1/2) + 1(\sqrt{3}/2)}{3(0)(\sqrt{3}/2) - 1(1/2)} = \frac{\sqrt{3}/2}{-1/2} = -\sqrt{3}.$$

$$61. r = 3 \cos \theta \Rightarrow x = r \cos \theta = 3 \cos \theta \cos \theta, y = r \sin \theta = 3 \cos \theta \sin \theta \Rightarrow$$

$$dy/d\theta = -3 \sin^2 \theta + 3 \cos^2 \theta = 3 \cos 2\theta = 0 \Rightarrow 2\theta = \frac{\pi}{2} \text{ or } \frac{3\pi}{2} \Leftrightarrow \theta = \frac{\pi}{4} \text{ or } \frac{3\pi}{4}. \text{ So the tangent is}$$

$$\text{horizontal at } \left(\frac{3}{\sqrt{2}}, \frac{\pi}{4}\right) \text{ and } \left(-\frac{3}{\sqrt{2}}, \frac{3\pi}{4}\right) \left[\text{same as } \left(\frac{3}{\sqrt{2}}, -\frac{\pi}{4}\right)\right]. dx/d\theta = -6 \sin \theta \cos \theta = -3 \sin 2\theta = 0 \Rightarrow$$

$$2\theta = 0 \text{ or } \pi \Leftrightarrow \theta = 0 \text{ or } \frac{\pi}{2}. \text{ So the tangent is vertical at } (3, 0) \text{ and } (0, \frac{\pi}{2}).$$

$$62. y = r \sin \theta = \cos \theta \sin \theta + \sin^2 \theta = \frac{1}{2} \sin 2\theta + \sin^2 \theta \Rightarrow dy/d\theta = \cos 2\theta + \sin 2\theta = 0 \Rightarrow \tan 2\theta = -1$$

$$\Rightarrow 2\theta = \frac{3\pi}{4} \text{ or } \frac{7\pi}{4} \Leftrightarrow \theta = \frac{3\pi}{8} \text{ or } \frac{7\pi}{8} \Rightarrow \text{horizontal tangents at } \left(\cos \frac{3\pi}{8} + \sin \frac{3\pi}{8}, \frac{3\pi}{8}\right) \text{ and}$$

$$\left(\cos \frac{7\pi}{8} + \sin \frac{7\pi}{8}, \frac{7\pi}{8}\right). x = r \cos \theta = \cos^2 \theta + \cos \theta \sin \theta \Rightarrow dx/d\theta = -\sin 2\theta + \cos 2\theta = 0 \Rightarrow$$

$$\tan 2\theta = 1 \Rightarrow 2\theta = \frac{\pi}{4} \text{ or } \frac{5\pi}{4} \Leftrightarrow \theta = \frac{\pi}{8} \text{ or } \frac{5\pi}{8} \Rightarrow \text{vertical tangents at } \left(\cos \frac{\pi}{8} + \sin \frac{\pi}{8}, \frac{\pi}{8}\right) \text{ and}$$

$$\left(\cos \frac{5\pi}{8} + \sin \frac{5\pi}{8}, \frac{5\pi}{8}\right).$$

Note: These expressions can be simplified using trigonometric identities. For example,

$$\cos \frac{\pi}{8} + \sin \frac{\pi}{8} = \frac{1}{2} \sqrt{4 + 2\sqrt{2}}.$$



63.  $r = 1 + \cos \theta \Rightarrow x = r \cos \theta = \cos \theta(1 + \cos \theta), y = r \sin \theta = \sin \theta(1 + \cos \theta) \Rightarrow$   
 $dy/d\theta = (1 + \cos \theta) \cos \theta - \sin^2 \theta = 2 \cos^2 \theta + \cos \theta - 1 = (2 \cos \theta - 1)(\cos \theta + 1) = 0 \Rightarrow \cos \theta = \frac{1}{2}$  or  
 $-1 \Rightarrow \theta = \frac{\pi}{3}, \pi$ , or  $\frac{5\pi}{3} \Rightarrow$  horizontal tangent at  $(\frac{3}{2}, \frac{\pi}{3}), (0, \pi)$  [the pole], and  $(\frac{3}{2}, \frac{5\pi}{3})$ .  
 $dx/d\theta = -(1 + \cos \theta) \sin \theta - \cos \theta \sin \theta = -\sin \theta(1 + 2 \cos \theta) = 0 \Rightarrow \sin \theta = 0$  or  $\cos \theta = -\frac{1}{2} \Rightarrow$   
 $\theta = 0, \pi, \frac{2\pi}{3}$ , or  $\frac{4\pi}{3} \Rightarrow$  vertical tangent at  $(2, 0), (\frac{1}{2}, \frac{2\pi}{3}),$  and  $(\frac{1}{2}, \frac{4\pi}{3})$ . Note that the tangent is horizontal, not  
 vertical when  $\theta = \pi$ , since  $\lim_{\theta \rightarrow \pi} \frac{dy/d\theta}{dx/d\theta} = 0$ .

64.  $\frac{dy}{d\theta} = e^\theta \sin \theta + e^\theta \cos \theta = e^\theta(\sin \theta + \cos \theta) = 0 \Rightarrow \sin \theta = -\cos \theta \Rightarrow \tan \theta = -1 \Rightarrow$   
 $\theta = -\frac{1}{4}\pi + n\pi$  ( $n$  any integer)  $\Rightarrow$  horizontal tangents at  $(e^{\pi(n-1/4)}, \pi(n - \frac{1}{4}))$ .  
 $\frac{dx}{d\theta} = e^\theta \cos \theta - e^\theta \sin \theta = e^\theta(\cos \theta - \sin \theta) = 0 \Rightarrow \sin \theta = \cos \theta \Rightarrow \tan \theta = 1 \Rightarrow$   
 $\theta = \frac{1}{4}\pi + n\pi$  ( $n$  any integer)  $\Rightarrow$  vertical tangents at  $(e^{\pi(n+1/4)}, \pi(n + \frac{1}{4}))$ .

65.  $r = \cos 2\theta \Rightarrow x = r \cos \theta = \cos 2\theta \cos \theta, y = r \sin \theta = \cos 2\theta \sin \theta \Rightarrow$   
 $dy/d\theta = -2 \sin 2\theta \sin \theta + \cos 2\theta \cos \theta = -4 \sin^2 \theta \cos \theta + (\cos^3 \theta - \sin^2 \theta \cos \theta)$   
 $= \cos \theta(\cos^2 \theta - 5 \sin^2 \theta) = \cos \theta(1 - 6 \sin^2 \theta) = 0 \Rightarrow$   
 $\cos \theta = 0$  or  $\sin \theta = \pm \frac{1}{\sqrt{6}} \Rightarrow \theta = \frac{\pi}{2}, \frac{3\pi}{2}, \alpha, \pi - \alpha, \pi + \alpha,$  or  $2\pi - \alpha$  (where  $\alpha = \sin^{-1} \frac{1}{\sqrt{6}}$ ).  
 So the tangent is horizontal at  $(-1, \frac{\pi}{2}), (-1, \frac{3\pi}{2}), (\frac{2}{3}, \alpha), (\frac{2}{3}, \pi - \alpha), (\frac{2}{3}, \pi + \alpha),$  and  $(\frac{2}{3}, 2\pi - \alpha)$ .

$$\frac{dx}{d\theta} = -2 \sin 2\theta \cos \theta - \cos 2\theta \sin \theta = -4 \sin \theta \cos^2 \theta - (2 \cos^2 \theta - 1) \sin \theta$$

$$= \sin \theta(1 - 6 \cos^2 \theta) = 0 \Rightarrow$$

- $\sin \theta = 0$  or  $\cos \theta = \pm \frac{1}{\sqrt{6}} \Rightarrow \theta = 0, \pi, \beta, \pi - \beta, \pi + \beta,$  or  $2\pi - \beta$  (where  $\beta = \cos^{-1} \frac{1}{\sqrt{6}}$ ).  
 So the tangent is vertical at  $(1, 0), (1, \pi), (-\frac{2}{3}, \beta), (-\frac{2}{3}, \pi - \beta), (-\frac{2}{3}, \pi + \beta),$  and  $(-\frac{2}{3}, 2\pi - \beta)$ .

66. By differentiating implicitly,  $r^2 = \sin 2\theta \Rightarrow 2r(dr/d\theta) = 2 \cos 2\theta \Rightarrow$

$dr/d\theta = (1/r) \cos 2\theta$ , so

$$\frac{dy}{d\theta} = \frac{1}{r} \cos 2\theta \sin \theta + r \cos \theta = \frac{1}{r}(\cos 2\theta \sin \theta + r^2 \cos \theta)$$

$$= \frac{1}{r}(\cos 2\theta \sin \theta + \sin 2\theta \cos \theta) = \frac{1}{r} \sin 3\theta$$

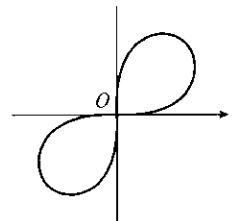

This is 0 when  $\sin 3\theta = 0 \Rightarrow \theta = 0, \frac{\pi}{3}$  or  $\frac{4\pi}{3}$  (restricting  $\theta$  to the domain of the lemniscate), so there are  
 horizontal tangents at  $(\sqrt[4]{\frac{3}{4}}, \frac{\pi}{3}), (\sqrt[4]{\frac{3}{4}}, \frac{4\pi}{3})$  and  $(0, 0)$ . Similarly,  $dx/d\theta = (1/r) \cos 3\theta = 0$  when  $\theta = \frac{\pi}{6}$  or  $\frac{7\pi}{6}$ ,  
 so there are vertical tangents at  $(\sqrt[4]{\frac{3}{4}}, \frac{\pi}{6})$  and  $(\sqrt[4]{\frac{3}{4}}, \frac{7\pi}{6})$  [and  $(0, 0)$ ].

67.  $r = a \sin \theta + b \cos \theta \Rightarrow r^2 = ar \sin \theta + br \cos \theta \Rightarrow x^2 + y^2 = ay + bx \Rightarrow$   
 $x^2 - bx + (\frac{1}{2}b)^2 + y^2 - ay + (\frac{1}{2}a)^2 = (\frac{1}{2}b)^2 + (\frac{1}{2}a)^2 \Rightarrow (x - \frac{1}{2}b)^2 + (y - \frac{1}{2}a)^2 = \frac{1}{4}(a^2 + b^2)$ , and this  
 is a circle with center  $(\frac{1}{2}b, \frac{1}{2}a)$  and radius  $\frac{1}{2}\sqrt{a^2 + b^2}$ .

68. These curves are circles which intersect at the origin and at  $(\frac{1}{\sqrt{2}}a, \frac{\pi}{4})$ . At the origin, the first circle has a horizontal tangent and the second a vertical one, so the tangents are perpendicular here. For the first circle ( $r = a \sin \theta$ ),  $dy/d\theta = a \cos \theta \sin \theta + a \sin \theta \cos \theta = a \sin 2\theta = a$  at  $\theta = \frac{\pi}{4}$  and  $dx/d\theta = a \cos^2 \theta - a \sin^2 \theta = a \cos 2\theta = 0$  at  $\theta = \frac{\pi}{4}$ , so the tangent here is vertical. Similarly, for the second circle ( $r = a \cos \theta$ ),  $dy/d\theta = a \cos 2\theta = 0$  and  $dx/d\theta = -a \sin 2\theta = -a$  at  $\theta = \frac{\pi}{4}$ , so the tangent is horizontal, and again the tangents are perpendicular.

Note for Exercises 69–74: Maple is able to plot polar curves using the `polarplot` command, or using the `coords=polar` option in a regular `plot` command. In Mathematica, use `PolarPlot`. In Derive, change to `Polar` under `Options State`. If your graphing device cannot plot polar equations, you must convert to parametric equations. For example, in Exercise 69,  $x = r \cos \theta = [1 + 2 \sin(\theta/2)] \cos \theta$ ,  $y = r \sin \theta = [1 + 2 \sin(\theta/2)] \sin \theta$ .

69.  $r = 1 + 2 \sin(\theta/2)$ . The parameter interval is  $[0, 4\pi]$ .

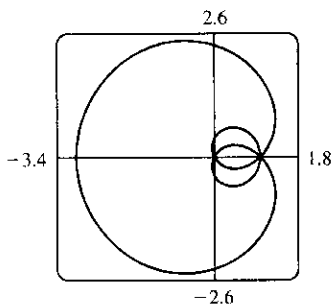

70.  $r = \sqrt{1 - 0.8 \sin^2 \theta}$ . The parameter interval is  $[0, 2\pi]$ .

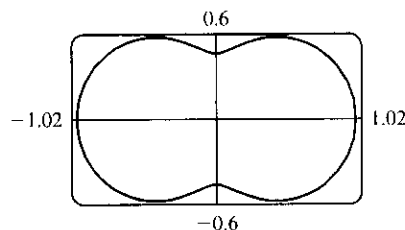

71.  $r = e^{\sin \theta} - 2 \cos(4\theta)$ . The parameter interval is  $[0, 2\pi]$ .

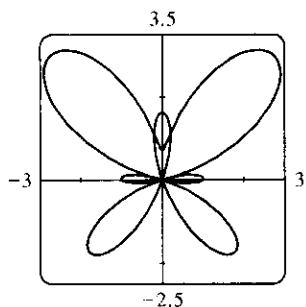

72.  $r = \sin^2(4\theta) + \cos(4\theta)$ . The parameter interval is  $[0, 2\pi]$ .

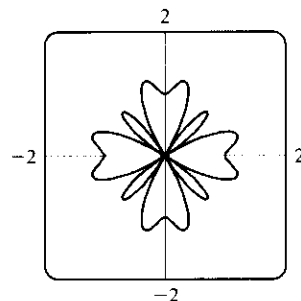

73.  $r = 2 - 5 \sin(\theta/6)$ . The parameter interval is  $[-6\pi, 6\pi]$ .

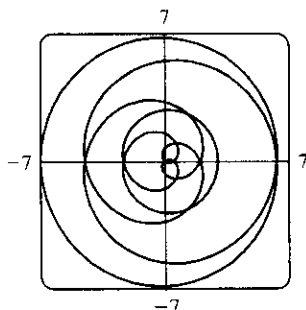

74.  $r = \cos(\theta/2) + \cos(\theta/3)$ . The parameter interval is  $[-6\pi, 6\pi]$ .

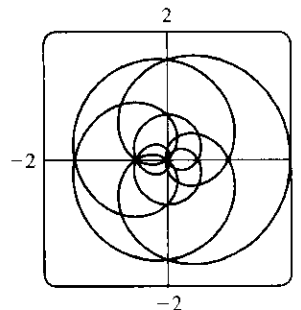

75.

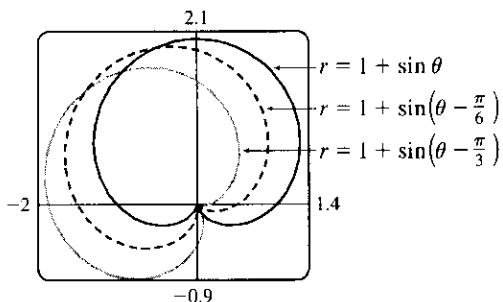

It appears that the graph of  $r = 1 + \sin(\theta - \frac{\pi}{6})$  is the same shape as the graph of  $r = 1 + \sin \theta$ , but rotated counterclockwise about the origin by  $\frac{\pi}{6}$ . Similarly, the graph of  $r = 1 + \sin(\theta - \frac{\pi}{3})$  is rotated by  $\frac{\pi}{3}$ . In general, the graph of  $r = f(\theta - \alpha)$  is the same shape as that of  $r = f(\theta)$ , but rotated counterclockwise through  $\alpha$  about the origin. That is, for any point  $(r_0, \theta_0)$  on the curve  $r = f(\theta)$ , the point  $(r_0, \theta_0 + \alpha)$  is on the curve  $r = f(\theta - \alpha)$ , since  $r_0 = f(\theta_0) = f((\theta_0 + \alpha) - \alpha)$ .

76.

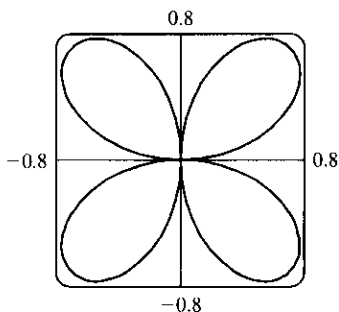

From the graph, the highest points seem to have  $y \approx 0.77$ . To find the exact value, we solve  $dy/d\theta = 0$ .  $y = r \sin \theta = \sin \theta \sin 2\theta \Rightarrow$

$$\begin{aligned} \frac{dy}{d\theta} &= 2 \sin \theta \cos 2\theta + \cos \theta \sin 2\theta \\ &= 2 \sin \theta (2 \cos^2 \theta - 1) + \cos \theta (2 \sin \theta \cos \theta) \\ &= 2 \sin \theta (3 \cos^2 \theta - 1) \end{aligned}$$

In the first quadrant, this is 0 when  $\cos \theta = \frac{1}{\sqrt{3}} \Leftrightarrow \sin \theta = \sqrt{\frac{2}{3}} \Leftrightarrow y = 2 \sin^2 \theta \cos \theta = 2 \cdot \frac{2}{3} \cdot \frac{1}{\sqrt{3}} = \frac{4\sqrt{3}}{9} \approx 0.77$ .

77. (a)  $r = \sin n\theta$ . From the graphs, it seems that when  $n$  is even, the number of loops in the curve (called a rose) is  $2n$ , and when  $n$  is odd, the number of loops is simply  $n$ .

This is because in the case of  $n$  odd, every point on the graph is traversed twice, due to the fact that

$$r(\theta + \pi) = \sin [n(\theta + \pi)] = \sin n\theta \cos n\pi + \cos n\theta \sin n\pi = \begin{cases} \sin n\theta & \text{if } n \text{ is even} \\ -\sin n\theta & \text{if } n \text{ is odd} \end{cases}$$

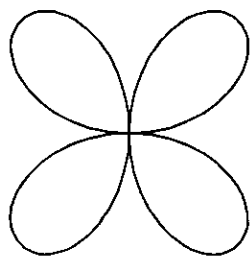

$n = 2$

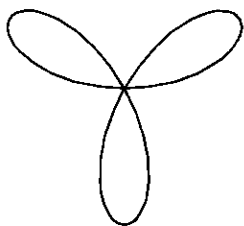

$n = 3$

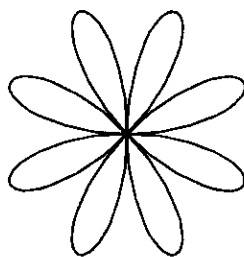

$n = 4$

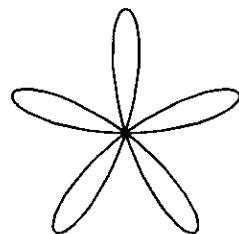

$n = 5$

(b) The graph of  $r = |\sin n\theta|$  has  $2n$  loops whether  $n$  is odd or even, since  $r(\theta + \pi) = r(\theta)$ .

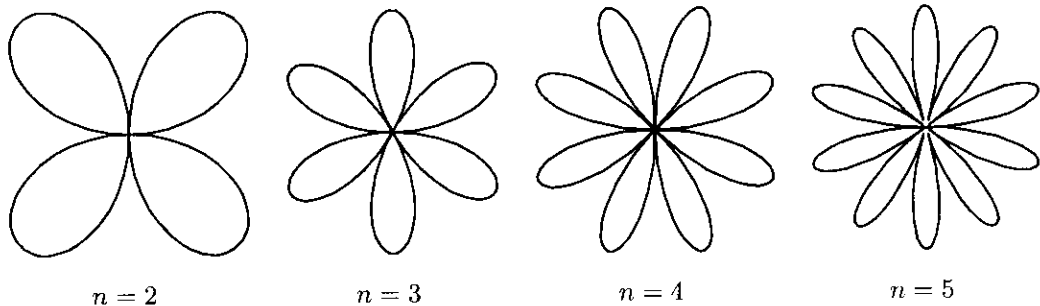

**78.**  $r = 1 + c \sin n\theta$ . We vary  $n$  while keeping  $c$  constant at 2. As  $n$  changes, the curves change in the same way as those in Exercise 77: the number of loops increases. Note that if  $n$  is even, the smaller loops are outside the larger ones; if  $n$  is odd, they are inside.

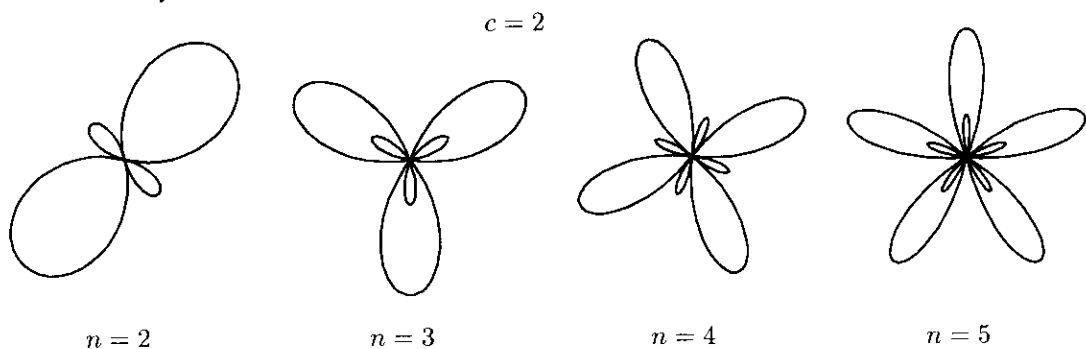

Now we vary  $c$  while keeping  $n = 3$ . As  $c$  increases toward 0, the entire graph gets smaller (the graphs below are not to scale) and the smaller loops shrink in relation to the large ones. At  $c = -1$ , the small loops disappear entirely, and for  $-1 < c < 1$ , the graph is a simple, closed curve (at  $c = 0$  it is a circle). As  $c$  continues to increase, the same changes are seen, but in reverse order, since  $1 + (-c) \sin n\theta = 1 + c \sin n(\theta + \pi)$ , so the graph for  $c = c_0$  is the same as that for  $c = -c_0$ , with a rotation through  $\pi$ . As  $c \rightarrow \infty$ , the smaller loops get relatively closer in size to the large ones. Note that the distance between the outermost points of corresponding inner and outer loops is always 2. Maple's `animate` command (or Mathematica's `Animate`) is very useful for seeing the changes that occur as  $c$  varies.

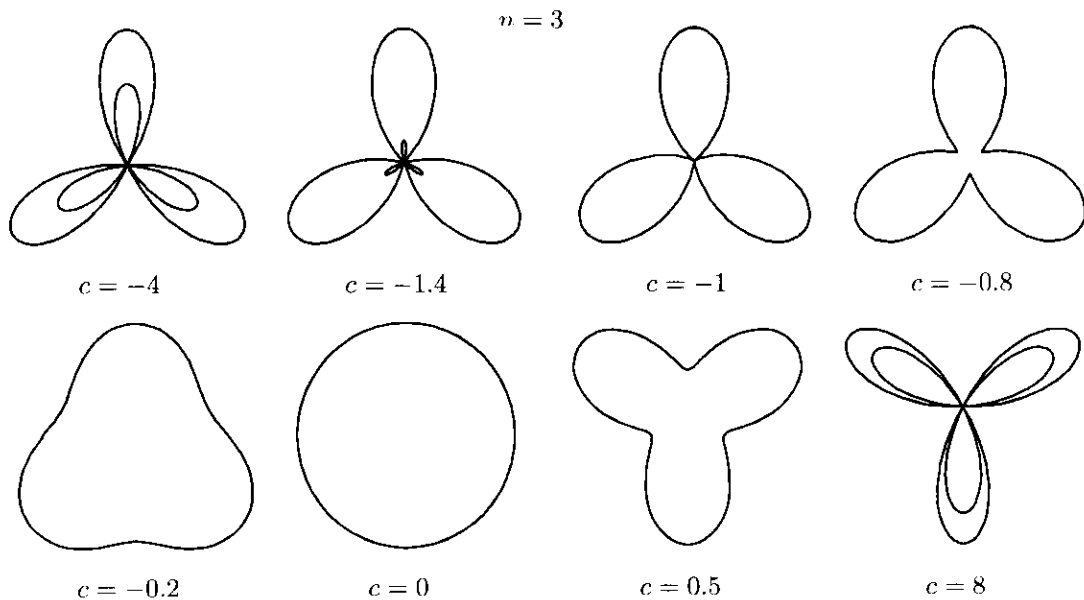

79.  $r = \frac{1 - a \cos \theta}{1 + a \cos \theta}$ . We start with  $a = 0$ , since in this case the curve is simply the circle  $r = 1$ .

As  $a$  increases, the graph moves to the left, and its right side becomes flattened. As  $a$  increases through about 0.4, the right side seems to grow a dimple, which upon closer investigation (with narrower  $\theta$ -ranges) seems to appear at  $a \approx 0.42$  (the actual value is  $\sqrt{2} - 1$ ). As  $a \rightarrow 1$ , this dimple becomes more pronounced, and the curve begins to stretch out horizontally, until at  $a = 1$  the denominator vanishes at  $\theta = \pi$ , and the dimple becomes an actual cusp. For  $a > 1$  we must choose our parameter interval carefully, since  $r \rightarrow \infty$  as  $1 + a \cos \theta \rightarrow 0 \Leftrightarrow \theta \rightarrow \pm \cos^{-1}(-1/a)$ . As  $a$  increases from 1, the curve splits into two parts. The left part has a loop, which grows larger as  $a$  increases, and the right part grows broader vertically, and its left tip develops a dimple when  $a \approx 2.42$  (actually,  $\sqrt{2} + 1$ ). As  $a$  increases, the dimple grows more and more pronounced. If  $a < 0$ , we get the same graph as we do for the corresponding positive  $a$ -value, but with a rotation through  $\pi$  about the pole, as happened when  $c$  was replaced with  $-c$  in Exercise 78.

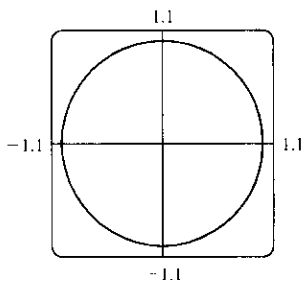

$a = 0$

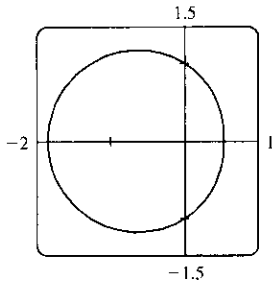

$a = 0.3$

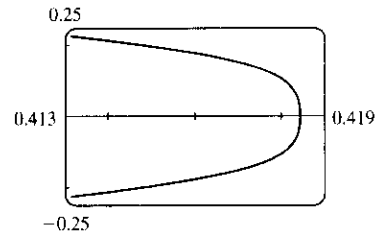

$a = 0.41, |\theta| \leq 0.5$

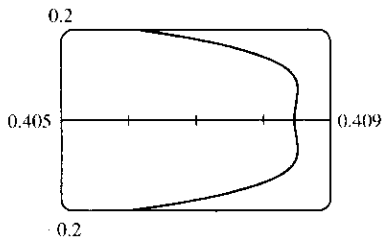

$a = 0.42, |\theta| \leq 0.5$

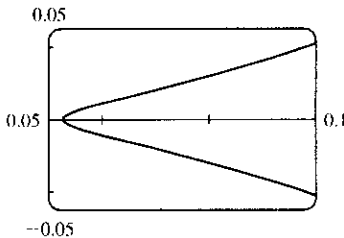

$a = 0.9, |\theta| \leq 0.5$

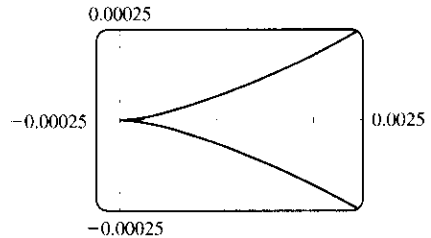

$a = 1, |\theta| \leq 0.1$

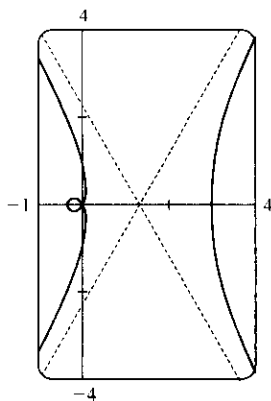

$a = 2$

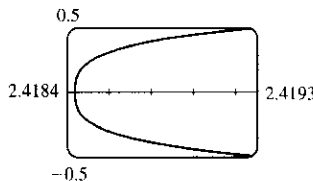

$a = 2.41, |\theta - \pi| \leq 0.2$

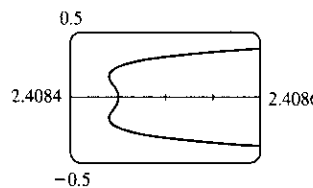

$a = 2.42, |\theta - \pi| \leq 0.2$

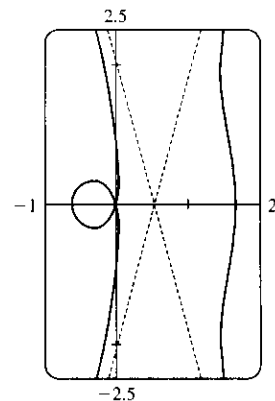

$a = 4$

80. Most graphing devices cannot plot implicit polar equations, so we must first find an explicit expression (or expressions) for  $r$  in terms of  $\theta$ ,  $a$ , and  $c$ . We note that the given equation is a quadratic in  $r^2$ , so we use the quadratic formula and find that

$$\begin{aligned} r^2 &= \frac{2c^2 \cos 2\theta \pm \sqrt{4c^4 \cos^2 2\theta - 4(c^4 - a^4)}}{2} \\ &= c^2 \cos 2\theta \pm \sqrt{a^4 - c^4 \sin^2 2\theta} \end{aligned}$$

so  $r = \pm \sqrt{c^2 \cos 2\theta \pm \sqrt{a^4 - c^4 \sin^2 2\theta}}$ . So for each graph, we must plot four curves to be sure of plotting all the points which satisfy the given equation. Note that all four functions have period  $\pi$ .

We start with the case  $a = c = 1$ , and the resulting curve resembles the symbol for infinity. If we let  $a$  decrease, the curve splits into two symmetric parts, and as  $a$  decreases further, the parts become smaller, further apart, and rounder. If instead we let  $a$  increase from 1, the two lobes of the curve join together, and as  $a$  increases further they continue to merge, until at  $a \approx 1.4$ , the graph no longer has dimples, and has an oval shape. As  $a \rightarrow \infty$ , the oval becomes larger and rounder, since the  $c^2$  and  $c^4$  terms lose their significance. Note that the shape of the graph seems to depend only on the ratio  $c/a$ , while the size of the graph varies as  $c$  and  $a$  jointly increase.

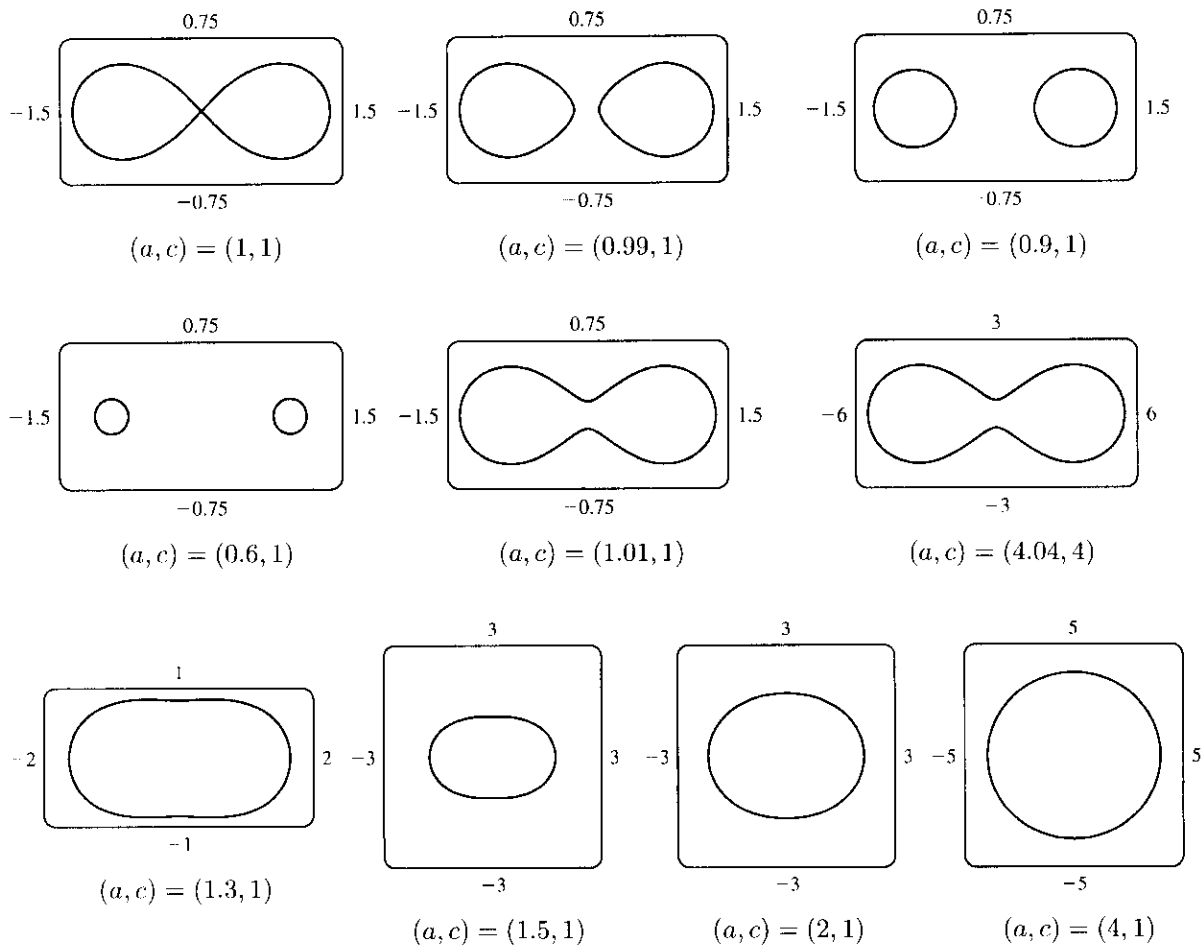

$$\begin{aligned}
 81. \quad \tan \psi &= \tan(\phi - \theta) = \frac{\tan \phi - \tan \theta}{1 + \tan \phi \tan \theta} = \frac{\frac{dy}{dx} - \tan \theta}{1 + \frac{dy}{dx} \tan \theta} = \frac{\frac{dy/d\theta}{dx/d\theta} - \tan \theta}{1 + \frac{dy/d\theta}{dx/d\theta} \tan \theta} \\
 &= \frac{\frac{dy}{d\theta} - \frac{dx}{d\theta} \tan \theta}{\frac{dx}{d\theta} + \frac{dy}{d\theta} \tan \theta} = \frac{\left(\frac{dr}{d\theta} \sin \theta + r \cos \theta\right) - \tan \theta \left(\frac{dr}{d\theta} \cos \theta - r \sin \theta\right)}{\left(\frac{dr}{d\theta} \cos \theta - r \sin \theta\right) + \tan \theta \left(\frac{dr}{d\theta} \sin \theta + r \cos \theta\right)} \\
 &= \frac{r \cos \theta + r \cdot \frac{\sin^2 \theta}{\cos \theta}}{\frac{dr}{d\theta} \cos \theta + \frac{dr}{d\theta} \cdot \frac{\sin^2 \theta}{\cos \theta}} = \frac{r \cos^2 \theta + r \sin^2 \theta}{\frac{dr}{d\theta} \cos^2 \theta + \frac{dr}{d\theta} \sin^2 \theta} = \frac{r}{dr/d\theta}
 \end{aligned}$$

82. (a)  $r = e^\theta \Rightarrow dr/d\theta = e^\theta$ , so by Exercise 81,  $\tan \psi = r/e^\theta = 1 \Rightarrow \psi = \arctan 1 = \frac{\pi}{4}$ .
- (b) The Cartesian equation of the tangent line at  $(1, 0)$  is  $y = x - 1$ , and that of the tangent line at  $(0, e^{\pi/2})$  is  $y = e^{\pi/2} - x$ .

- (c) Let  $a$  be the tangent of the angle between the tangent and radial lines, that is,  $a = \tan \psi$ . Then, by Exercise 81,  $a = \frac{r}{dr/d\theta} \Rightarrow \frac{dr}{d\theta} = \frac{1}{a} r \Rightarrow r = C e^{\theta/a}$  (by Theorem 10.4.2).

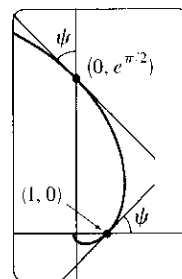

## 11.4 Areas and Lengths in Polar Coordinates

- $r = \sqrt{\theta}, 0 \leq \theta \leq \frac{\pi}{4}$ .  $A = \int_0^{\pi/4} \frac{1}{2} r^2 d\theta = \int_0^{\pi/4} \frac{1}{2} (\sqrt{\theta})^2 d\theta = \int_0^{\pi/4} \frac{1}{2} \theta d\theta = \left[\frac{1}{4} \theta^2\right]_0^{\pi/4} = \frac{1}{64} \pi^2$
- $r = e^{\theta/2}, \pi \leq \theta \leq 2\pi$ .  $A = \int_{\pi}^{2\pi} \frac{1}{2} (e^{\theta/2})^2 d\theta = \int_{\pi}^{2\pi} \frac{1}{2} e^{\theta} d\theta = \frac{1}{2} [e^{\theta}]_{\pi}^{2\pi} = \frac{1}{2} (e^{2\pi} - e^{\pi})$
- $r = \sin \theta, \frac{\pi}{3} \leq \theta \leq \frac{2\pi}{3}$ .

$$\begin{aligned}
 A &= \int_{\pi/3}^{2\pi/3} \frac{1}{2} \sin^2 \theta d\theta = \frac{1}{4} \int_{\pi/3}^{2\pi/3} (1 - \cos 2\theta) d\theta = \frac{1}{4} \left[ \theta - \frac{1}{2} \sin 2\theta \right]_{\pi/3}^{2\pi/3} \\
 &= \frac{1}{4} \left[ \frac{2\pi}{3} - \frac{1}{2} \sin \frac{4\pi}{3} - \frac{\pi}{3} + \frac{1}{2} \sin \frac{2\pi}{3} \right] = \frac{1}{4} \left[ \frac{2\pi}{3} - \frac{1}{2} \left( -\frac{\sqrt{3}}{2} \right) - \frac{\pi}{3} + \frac{1}{2} \left( \frac{\sqrt{3}}{2} \right) \right] = \frac{1}{4} \left( \frac{\pi}{3} + \frac{\sqrt{3}}{2} \right) = \frac{\pi}{12} + \frac{\sqrt{3}}{8}
 \end{aligned}$$

- $r = \sqrt{\sin \theta}, 0 \leq \theta \leq \pi$ .  $A = \int_0^{\pi} \frac{1}{2} (\sqrt{\sin \theta})^2 d\theta = \int_0^{\pi} \frac{1}{2} \sin \theta d\theta = \left[ -\frac{1}{2} \cos \theta \right]_0^{\pi} = \frac{1}{2} + \frac{1}{2} = 1$
- $r = \theta, 0 \leq \theta \leq \pi$ .  $A = \int_0^{\pi} \frac{1}{2} \theta^2 d\theta = \left[ \frac{1}{6} \theta^3 \right]_0^{\pi} = \frac{1}{6} \pi^3$
- $r = 1 + \sin \theta, \frac{\pi}{2} \leq \theta \leq \pi$ .  $A = \int_{\pi/2}^{\pi} \frac{1}{2} (1 + \sin \theta)^2 d\theta = \frac{1}{2} \int_{\pi/2}^{\pi} (1 + 2 \sin \theta + \sin^2 \theta) d\theta = \frac{1}{2} \int_{\pi/2}^{\pi} \left[ 1 + 2 \sin \theta + \frac{1}{2} (1 - \cos 2\theta) \right] d\theta$   
 $= \frac{1}{2} \left[ \theta - 2 \cos \theta + \frac{1}{2} \theta - \frac{1}{4} \sin 2\theta \right]_{\pi/2}^{\pi} = \frac{1}{2} \left[ \pi + 2 + \frac{\pi}{2} - 0 - \left( \frac{\pi}{2} - 0 + \frac{\pi}{4} - 0 \right) \right] = \frac{1}{2} \left( \frac{3\pi}{4} + 2 \right) = \frac{3\pi}{8} + 1$

7.  $r = 4 + 3 \sin \theta, -\frac{\pi}{2} \leq \theta \leq \frac{\pi}{2}.$

$$\begin{aligned} A &= \int_{-\pi/2}^{\pi/2} \frac{1}{2}(4 + 3 \sin \theta)^2 d\theta = \frac{1}{2} \int_{-\pi/2}^{\pi/2} (16 + 24 \sin \theta + 9 \sin^2 \theta) d\theta \\ &= \frac{1}{2} \int_{-\pi/2}^{\pi/2} (16 + 9 \sin^2 \theta) d\theta \quad [\text{by Theorem 5.5.6(b)}] \\ &= \frac{1}{2} \cdot 2 \int_0^{\pi/2} [16 + 9 \cdot \frac{1}{2}(1 - \cos 2\theta)] d\theta \quad [\text{by Theorem 5.5.6(a)}] \\ &= \int_0^{\pi/2} (\frac{41}{2} - \frac{9}{2} \cos 2\theta) d\theta = [\frac{41}{2}\theta - \frac{9}{4} \sin 2\theta]_0^{\pi/2} = (\frac{41\pi}{4} - 0) - (0 - 0) = \frac{41\pi}{4} \end{aligned}$$

8.  $r = \sin 4\theta, 0 \leq \theta \leq \frac{\pi}{4}.$   $A = \int_0^{\pi/4} \frac{1}{2} \sin^2 4\theta d\theta = \int_0^{\pi/4} \frac{1}{4}(1 - \cos 8\theta) d\theta = [\frac{1}{4}\theta - \frac{1}{32} \sin 8\theta]_0^{\pi/4} = \frac{\pi}{16}$

9. The area above the polar axis is bounded by  $r = 3 \cos \theta$  for  $\theta = 0$  to  $\theta = \pi/2$  (not  $\pi$ ). By symmetry,

$$\begin{aligned} A &= 2 \int_0^{\pi/2} \frac{1}{2} r^2 d\theta = \int_0^{\pi/2} (3 \cos \theta)^2 d\theta \\ &= 3^2 \int_0^{\pi/2} \cos^2 \theta d\theta = 9 \int_0^{\pi/2} \frac{1}{2}(1 + \cos 2\theta) d\theta \\ &= \frac{9}{2} [\theta + \frac{1}{2} \sin 2\theta]_0^{\pi/2} = \frac{9}{2} [(\frac{\pi}{2} + 0) - (0 + 0)] = \frac{9\pi}{4}. \end{aligned}$$

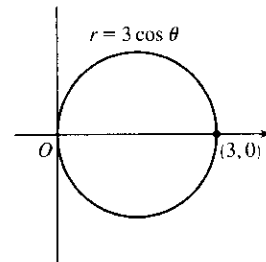

Also, note that this is a circle with radius  $\frac{3}{2}$ , so its area is  $\pi(\frac{3}{2})^2 = \frac{9\pi}{4}.$

10.  $A = \int_0^{2\pi} \frac{1}{2} r^2 d\theta = \int_0^{2\pi} \frac{1}{2} [3(1 + \cos \theta)]^2 d\theta$   
 $= \frac{9}{2} \int_0^{2\pi} (1 + 2 \cos \theta + \cos^2 \theta) d\theta$   
 $= \frac{9}{2} \int_0^{2\pi} [1 + 2 \cos \theta + \frac{1}{2}(1 + \cos 2\theta)] d\theta$   
 $= \frac{9}{2} [\frac{3}{2}\theta + 2 \sin \theta + \frac{1}{4} \sin 2\theta]_0^{2\pi} = \frac{27}{2} \pi$

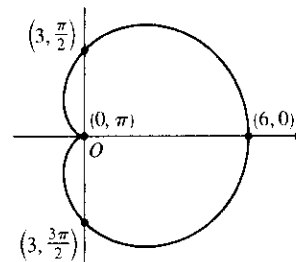

11. The curve  $r^2 = 4 \cos 2\theta$  goes through the pole when  $\theta = \pi/4$ , so we'll find the area for  $0 \leq \theta \leq \pi/4$  and multiply it by 4.

$$\begin{aligned} A &= 4 \int_0^{\pi/4} \frac{1}{2} r^2 d\theta = 2 \int_0^{\pi/4} (4 \cos 2\theta) d\theta \\ &= 8 \int_0^{\pi/4} \cos 2\theta d\theta = 4 [\sin 2\theta]_0^{\pi/4} = 4(1 - 0) = 4 \end{aligned}$$

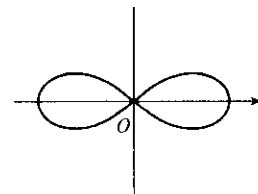

12. The curve  $r^2 = \sin 2\theta$  goes through the pole when  $\theta = \pi/2$ , so we'll find the area for  $0 \leq \theta \leq \pi/2$  and multiply it by 2.

$$\begin{aligned} A &= 2 \int_0^{\pi/2} \frac{1}{2} r^2 d\theta = \int_0^{\pi/2} \sin 2\theta d\theta = -\frac{1}{2} [\cos 2\theta]_0^{\pi/2} \\ &= -\frac{1}{2} (-1 - 1) = -\frac{1}{2} (-2) = 1 \end{aligned}$$

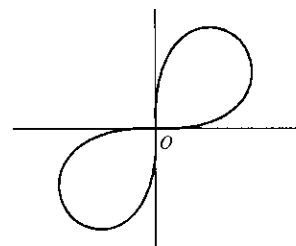



13. One-sixth of the area lies above the polar axis and is bounded by the curve  $r = 2 \cos 3\theta$  for  $\theta = 0$  to  $\theta = \pi/6$ .

$$\begin{aligned} A &= 6 \int_0^{\pi/6} \frac{1}{2} (2 \cos 3\theta)^2 d\theta = 12 \int_0^{\pi/6} \cos^2 3\theta d\theta \\ &= \frac{12}{2} \int_0^{\pi/6} (1 + \cos 6\theta) d\theta \\ &= 6 \left[ \theta + \frac{1}{6} \sin 6\theta \right]_0^{\pi/6} = 6 \left( \frac{\pi}{6} \right) = \pi \end{aligned}$$

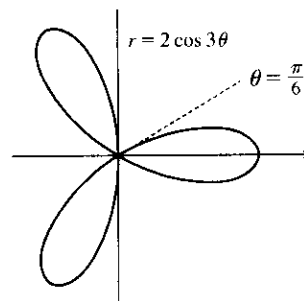

14.  $A = \int_0^{2\pi} \frac{1}{2} (2 + \cos 2\theta)^2 d\theta = \frac{1}{2} \int_0^{2\pi} (4 + 4 \cos 2\theta + \cos^2 2\theta) d\theta$

$$\begin{aligned} &= \frac{1}{2} \int_0^{2\pi} \left( 4 + 4 \cos 2\theta + \frac{1}{2} + \frac{1}{2} \cos 4\theta \right) d\theta \\ &= \frac{1}{2} \left[ \frac{9}{2}\theta + 2 \sin 2\theta + \frac{1}{8} \sin 4\theta \right]_0^{2\pi} \\ &= \frac{1}{2} (9\pi) = \frac{9\pi}{2} \end{aligned}$$

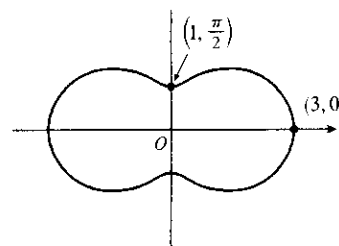

15.  $A = \int_0^{2\pi} \frac{1}{2} (1 + 2 \sin 6\theta)^2 d\theta = \frac{1}{2} \int_0^{2\pi} (1 + 4 \sin 6\theta + 4 \sin^2 6\theta) d\theta$

$$\begin{aligned} &= \frac{1}{2} \int_0^{2\pi} \left[ 1 + 4 \sin 6\theta + 4 \cdot \frac{1}{2} (1 - \cos 12\theta) \right] d\theta \\ &= \frac{1}{2} \int_0^{2\pi} (3 + 4 \sin 6\theta - 2 \cos 12\theta) d\theta \\ &= \frac{1}{2} \left[ 3\theta - \frac{2}{3} \cos 6\theta - \frac{1}{6} \sin 12\theta \right]_0^{2\pi} \\ &= \frac{1}{2} \left[ (6\pi - \frac{2}{3} - 0) - (0 - \frac{2}{3} - 0) \right] = 3\pi. \end{aligned}$$

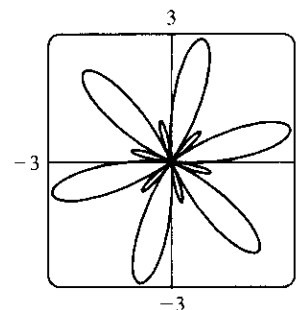

16.  $A = \int_0^{\pi} \frac{1}{2} (2 \sin \theta + 3 \sin 9\theta)^2 d\theta = 2 \int_0^{\pi/2} \frac{1}{2} (2 \sin \theta + 3 \sin 9\theta)^2 d\theta$

$$\begin{aligned} &= \int_0^{\pi/2} (4 \sin^2 \theta + 12 \sin \theta \sin 9\theta + 9 \sin^2 9\theta) d\theta \\ &= \int_0^{\pi/2} \left[ 2(1 - \cos 2\theta) + 12 \cdot \frac{1}{2} (\cos(\theta - 9\theta) - \cos(\theta + 9\theta)) + \frac{9}{2} (1 - \cos 18\theta) \right] d\theta \\ &\hspace{15em} \text{[integration by parts could be used for } \int \sin \theta \sin 9\theta d\theta \text{]} \\ &= \int_0^{\pi/2} \left( 2 - 2 \cos 2\theta + 6 \cos 8\theta - 6 \cos 10\theta + \frac{9}{2} - \frac{9}{2} \cos 18\theta \right) d\theta \\ &= \left[ \frac{13}{2}\theta - \sin 2\theta + \frac{3}{4} \sin 8\theta - \frac{3}{5} \sin 10\theta - \frac{1}{4} \sin 18\theta \right]_0^{\pi/2} = \frac{13}{4} \pi \end{aligned}$$

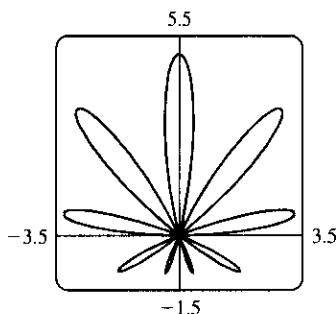

17. The shaded loop is traced out from  $\theta = 0$  to  $\theta = \pi/2$ .

$$\begin{aligned} A &= \int_0^{\pi/2} \frac{1}{2} r^2 d\theta = \frac{1}{2} \int_0^{\pi/2} \sin^2 2\theta d\theta \\ &= \frac{1}{2} \int_0^{\pi/2} \frac{1}{2} (1 - \cos 4\theta) d\theta \\ &= \frac{1}{4} \left[ \theta - \frac{1}{4} \sin 4\theta \right]_0^{\pi/2} = \frac{1}{4} \left( \frac{\pi}{2} \right) = \frac{\pi}{8} \end{aligned}$$

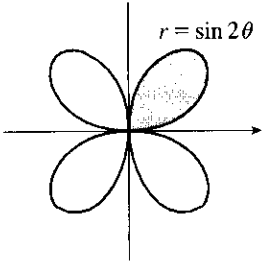

18.  $A = \int_0^{\pi/3} \frac{1}{2} (4 \sin 3\theta)^2 d\theta = 8 \int_0^{\pi/3} \sin^2 3\theta d\theta$   
 $= 4 \int_0^{\pi/3} (1 - \cos 6\theta) d\theta$   
 $= 4 \left[ \theta - \frac{1}{6} \sin 6\theta \right]_0^{\pi/3} = \frac{4\pi}{3}$

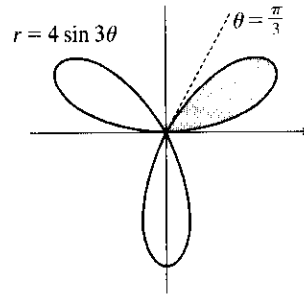

19.  $r = 0 \Rightarrow 3 \cos 5\theta = 0 \Rightarrow 5\theta = \frac{\pi}{2} \Rightarrow \theta = \frac{\pi}{10}$ .

$$A = \int_{-\pi/10}^{\pi/10} \frac{1}{2} (3 \cos 5\theta)^2 d\theta = \int_0^{\pi/10} 9 \cos^2 5\theta d\theta = \frac{9}{2} \int_0^{\pi/10} (1 + \cos 10\theta) d\theta = \frac{9}{2} \left[ \theta + \frac{1}{10} \sin 10\theta \right]_0^{\pi/10} = \frac{9\pi}{20}$$

20.  $A = 2 \int_0^{\pi/8} \frac{1}{2} (2 \cos 4\theta)^2 d\theta = 2 \int_0^{\pi/8} (1 + \cos 8\theta) d\theta = 2 \left[ \theta + \frac{1}{8} \sin 8\theta \right]_0^{\pi/8} = \frac{\pi}{4}$

21.  $r = 1 + 2 \sin \theta$  (rect.)

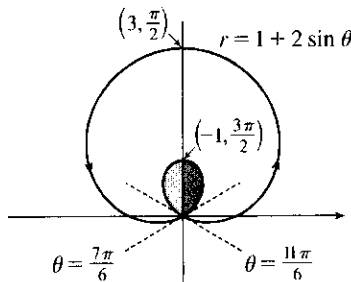
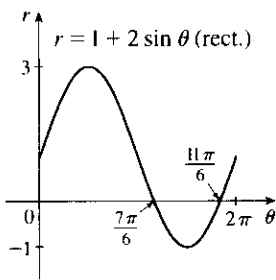

This is a limaçon, with inner loop traced out between  $\theta = \frac{7\pi}{6}$  and  $\frac{11\pi}{6}$  [found by solving  $r = 0$ ].

$$\begin{aligned} A &= 2 \int_{7\pi/6}^{3\pi/2} \frac{1}{2} (1 + 2 \sin \theta)^2 d\theta = \int_{7\pi/6}^{3\pi/2} (1 + 4 \sin \theta + 4 \sin^2 \theta) d\theta \\ &= \int_{7\pi/6}^{3\pi/2} \left[ 1 + 4 \sin \theta + 4 \cdot \frac{1}{2} (1 - \cos 2\theta) \right] d\theta = \left[ \theta - 4 \cos \theta + 2\theta - \sin 2\theta \right]_{7\pi/6}^{3\pi/2} \\ &= \left( \frac{9\pi}{2} \right) - \left( \frac{7\pi}{2} + 2\sqrt{3} - \frac{\sqrt{3}}{2} \right) = \pi - \frac{3\sqrt{3}}{2} \end{aligned}$$

22. To determine when the strophoid  $r = 2 \cos \theta - \sec \theta$  passes

$$\text{through the pole, we solve } r = 0 \Rightarrow 2 \cos \theta - \frac{1}{\cos \theta} = 0 \Rightarrow$$

$$2 \cos^2 \theta - 1 = 0 \Rightarrow \cos^2 \theta = \frac{1}{2} \Rightarrow \cos \theta = \pm \frac{1}{\sqrt{2}} \Rightarrow$$

$$\theta = \frac{\pi}{4} \text{ or } \theta = \frac{3\pi}{4} \text{ for } 0 \leq \theta \leq \pi \text{ with } \theta \neq \frac{\pi}{2}.$$

$$\begin{aligned} A &= 2 \int_0^{\pi/4} \frac{1}{2} (2 \cos \theta - \sec \theta)^2 d\theta = \int_0^{\pi/4} (4 \cos^2 \theta - 4 + \sec^2 \theta) d\theta \\ &= \int_0^{\pi/4} \left[ 4 \cdot \frac{1}{2} (1 + \cos 2\theta) - 4 + \sec^2 \theta \right] d\theta = \int_0^{\pi/4} (-2 + 2 \cos 2\theta + \sec^2 \theta) d\theta \\ &= \left[ -2\theta + \sin 2\theta + \tan \theta \right]_0^{\pi/4} = \left( -\frac{\pi}{2} + 1 + 1 \right) - 0 = 2 - \frac{\pi}{2} \end{aligned}$$

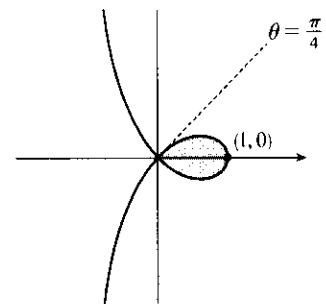

23.  $4 \sin \theta = 2 \Leftrightarrow \sin \theta = \frac{1}{2} \Leftrightarrow \theta = \frac{\pi}{6}$  or  $\frac{5\pi}{6}$  (for  $0 \leq \theta \leq 2\pi$ ). We'll subtract the unshaded area from the shaded area for  $\pi/6 \leq \theta \leq \pi/2$  and double that value.

$$\begin{aligned} A &= 2 \int_{\pi/6}^{\pi/2} \frac{1}{2} (4 \sin \theta)^2 d\theta - 2 \int_{\pi/6}^{\pi/2} \frac{1}{2} (2)^2 d\theta = 2 \int_{\pi/6}^{\pi/2} \frac{1}{2} [(4 \sin \theta)^2 - 2^2] d\theta \\ &= \int_{\pi/6}^{\pi/2} (16 \sin^2 \theta - 4) d\theta = \int_{\pi/6}^{\pi/2} [8(1 - \cos 2\theta) - 4] d\theta \\ &= \int_{\pi/6}^{\pi/2} (4 - 8 \cos 2\theta) d\theta = [4\theta - 4 \sin 2\theta]_{\pi/6}^{\pi/2} \\ &= (2\pi - 0) - \left( \frac{2\pi}{3} - 4 \cdot \frac{\sqrt{3}}{2} \right) = \frac{4}{3}\pi + 2\sqrt{3} \end{aligned}$$

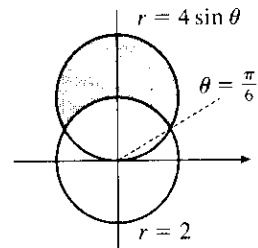

24.  $1 - \sin \theta = 1 \Rightarrow \sin \theta = 0 \Rightarrow \theta = 0$  or  $\pi \Rightarrow$

$$\begin{aligned} A &= \int_{\pi}^{2\pi} \frac{1}{2} [(1 - \sin \theta)^2 - 1] d\theta = \frac{1}{2} \int_{\pi}^{2\pi} (\sin^2 \theta - 2 \sin \theta) d\theta \\ &= \frac{1}{4} \int_{\pi}^{2\pi} (1 - \cos 2\theta - 4 \sin \theta) d\theta = \frac{1}{4} [\theta - \frac{1}{2} \sin 2\theta + 4 \cos \theta]_{\pi}^{2\pi} \\ &= \frac{1}{4}\pi + 2 \end{aligned}$$

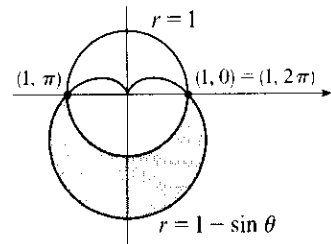

25. To find the area inside the lemniscate  $r^2 = 8 \cos 2\theta$  and outside the circle  $r = 2$ , we first note that the two curves intersect when  $r^2 = 8 \cos 2\theta$  and  $r = 2$ ; i.e., when  $\cos 2\theta = \frac{1}{2}$ . For  $-\pi < \theta \leq \pi$ ,  $\cos 2\theta = \frac{1}{2} \Leftrightarrow 2\theta = \pm\pi/3$  or  $\pm 5\pi/3 \Leftrightarrow \theta = \pm\pi/6$  or  $\pm 5\pi/6$ . The figure shows that the desired area is 4 times the area between the curves from 0 to  $\pi/6$ . Thus,

$$\begin{aligned} A &= 4 \int_0^{\pi/6} \left[ \frac{1}{2} (8 \cos 2\theta) - \frac{1}{2} (2)^2 \right] d\theta = 8 \int_0^{\pi/6} (2 \cos 2\theta - 1) d\theta \\ &= 8 \left[ \sin 2\theta - \theta \right]_0^{\pi/6} = 8 \left( \frac{\sqrt{3}}{2} - \pi/6 \right) = 4\sqrt{3} - 4\pi/3 \end{aligned}$$

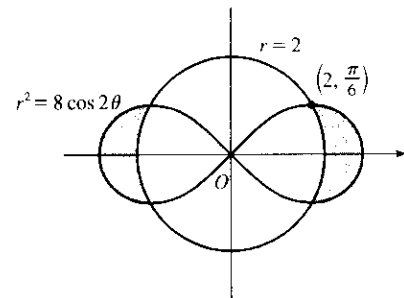

26. To find the shaded area  $A$ , we'll find the area  $A_1$  inside the curve  $r = 2 + \sin \theta$  and subtract  $\pi \left( \frac{3}{2} \right)^2$  since  $r = 3 \sin \theta$  is a circle with radius  $\frac{3}{2}$ .

$$\begin{aligned} A_1 &= \int_0^{2\pi} \frac{1}{2} (2 + \sin \theta)^2 d\theta = \frac{1}{2} \int_0^{2\pi} (4 + 4 \sin \theta + \sin^2 \theta) d\theta \\ &= \frac{1}{2} \int_0^{2\pi} \left[ 4 + 4 \sin \theta + \frac{1}{2} (1 - \cos 2\theta) \right] d\theta \\ &= \frac{1}{2} \int_0^{2\pi} \left( \frac{9}{2} + 4 \sin \theta - \frac{1}{2} \cos 2\theta \right) d\theta \\ &= \frac{1}{2} \left[ \frac{9}{2}\theta - 4 \cos \theta - \frac{1}{4} \sin 2\theta \right]_0^{2\pi} = \frac{1}{2} [(9\pi - 4) - (-4)] = \frac{9\pi}{2} \end{aligned}$$

So  $A = A_1 - \frac{9\pi}{4} = \frac{9\pi}{2} - \frac{9\pi}{4} = \frac{9\pi}{4}$ .

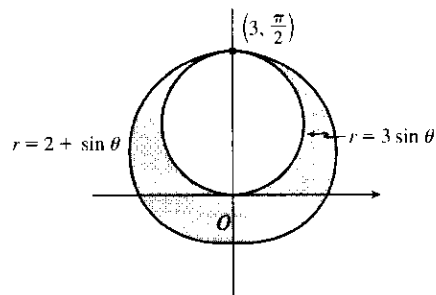

$$27. 3 \cos \theta = 1 + \cos \theta \Leftrightarrow \cos \theta = \frac{1}{2} \Rightarrow \theta = \frac{\pi}{3} \text{ or } -\frac{\pi}{3}.$$

$$\begin{aligned} A &= 2 \int_0^{\pi/3} \frac{1}{2} [(3 \cos \theta)^2 - (1 + \cos \theta)^2] d\theta \\ &= \int_0^{\pi/3} (8 \cos^2 \theta - 2 \cos \theta - 1) d\theta \\ &= \int_0^{\pi/3} [4(1 + \cos 2\theta) - 2 \cos \theta - 1] d\theta \\ &= \int_0^{\pi/3} (3 + 4 \cos 2\theta - 2 \cos \theta) d\theta \\ &= [3\theta + 2 \sin 2\theta - 2 \sin \theta]_0^{\pi/3} \\ &= \pi + \sqrt{3} - \sqrt{3} = \pi \end{aligned}$$

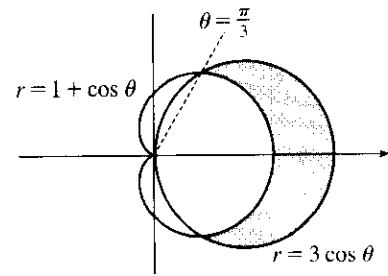

28. Note that  $r = 1 + \cos \theta$  goes through the pole when  $\theta = \pi$ ,

but  $r = 3 \cos \theta$  goes through the pole when  $\theta = \pi/2$ .

$$\begin{aligned} A &= 2 \int_{\pi/3}^{\pi} \frac{1}{2} (1 + \cos \theta)^2 d\theta - 2 \int_{\pi/3}^{\pi/2} \frac{1}{2} (3 \cos \theta)^2 d\theta \\ &= \int_{\pi/3}^{\pi} [1 + 2 \cos \theta + \frac{1}{2}(1 + \cos 2\theta)] d\theta - \frac{9}{2} \int_{\pi/3}^{\pi/2} (1 + \cos 2\theta) d\theta \\ &= [\theta + 2 \sin \theta + \frac{1}{2}(\theta + \frac{1}{2} \sin 2\theta)]_{\pi/3}^{\pi} - \frac{9}{2} [\theta + \frac{1}{2} \sin 2\theta]_{\pi/3}^{\pi/2} \\ &= (\pi - \frac{9}{8}\sqrt{3}) - \frac{9}{2}(\frac{\pi}{6} - \frac{1}{4}\sqrt{3}) = \frac{\pi}{4} \end{aligned}$$

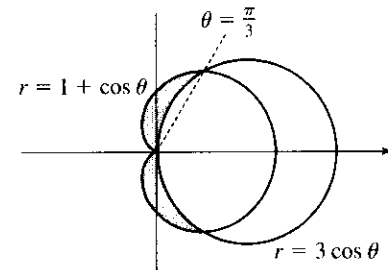

$$\begin{aligned} 29. A &= 2 \int_0^{\pi/4} \frac{1}{2} \sin^2 \theta d\theta = \int_0^{\pi/4} \frac{1}{2} (1 - \cos 2\theta) d\theta \\ &= \frac{1}{2} [\theta - \frac{1}{2} \sin 2\theta]_0^{\pi/4} = \frac{1}{2} [(\frac{\pi}{4} - \frac{1}{2} \cdot 1) - (0 - 0)] \\ &= \frac{1}{8} \pi - \frac{1}{4} \end{aligned}$$

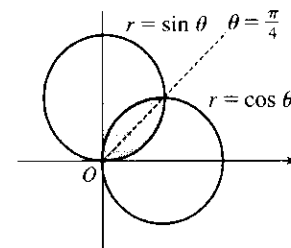

30.  $r = \sin 2\theta$  takes on both positive and negative values.

$\sin \theta = \pm \sin 2\theta = \pm 2 \sin \theta \cos \theta \Rightarrow \sin \theta (1 \pm 2 \cos \theta) = 0$ . From the figure we can see that the intersections occur where  $\cos \theta = \pm \frac{1}{2}$ , or  $\theta = \frac{\pi}{3}$  and  $\frac{2\pi}{3}$ .

$$\begin{aligned} A &= 2 \left[ \int_0^{\pi/3} \frac{1}{2} \sin^2 \theta d\theta + \int_{\pi/3}^{\pi/2} \frac{1}{2} \sin^2 2\theta d\theta \right] \\ &= \int_0^{\pi/3} \frac{1}{2} (1 - \cos 2\theta) d\theta + \int_{\pi/3}^{\pi/2} \frac{1}{2} (1 - \cos 4\theta) d\theta \\ &= \frac{1}{2} [\theta - \frac{1}{2} \sin 2\theta]_0^{\pi/3} + \frac{1}{2} [\theta - \frac{1}{4} \sin 4\theta]_{\pi/3}^{\pi/2} = \frac{4\pi - 3\sqrt{3}}{16} \end{aligned}$$

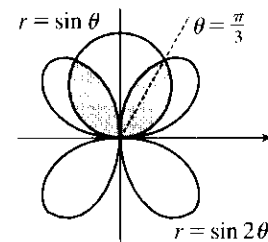

31.  $\sin 2\theta = \cos 2\theta \Rightarrow \frac{\sin 2\theta}{\cos 2\theta} = 1 \Rightarrow \tan 2\theta = 1 \Rightarrow$   
 $2\theta = \frac{\pi}{4} \Rightarrow \theta = \frac{\pi}{8} \Rightarrow$

$$A = 8 \cdot 2 \int_0^{\pi/8} \frac{1}{2} \sin^2 2\theta \, d\theta = 8 \int_0^{\pi/8} \frac{1}{2} (1 - \cos 4\theta) \, d\theta$$

$$= 4 \left[ \theta - \frac{1}{4} \sin 4\theta \right]_0^{\pi/8} = 4 \left( \frac{\pi}{8} - \frac{1}{4} \cdot 1 \right) = \frac{1}{2} \pi - 1$$

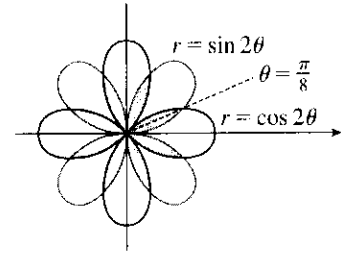

32.  $2 \sin 2\theta = 1^2 \Rightarrow \sin 2\theta = \frac{1}{2} \Rightarrow 2\theta = \frac{\pi}{6} \text{ or } \frac{5\pi}{6} \Rightarrow \theta = \frac{\pi}{12} \text{ or } \frac{5\pi}{12}$

$$A = 4 \left[ \int_0^{\pi/12} \frac{1}{2} \cdot 2 \sin 2\theta \, d\theta + \int_{\pi/12}^{\pi/4} \frac{1}{2} (1^2) \, d\theta \right]$$

$$= [-2 \cos 2\theta]_0^{\pi/12} + [2\theta]_{\pi/12}^{\pi/4}$$

$$= -2 \left( \frac{\sqrt{3}}{2} - 1 \right) + 2 \left( \frac{1}{4} \pi - \frac{1}{12} \pi \right)$$

$$= 2 - \sqrt{3} + \frac{\pi}{3}$$

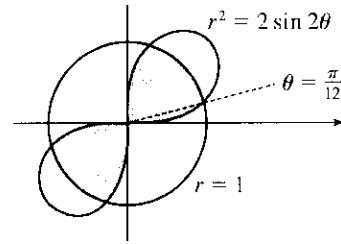

33.  $A = 2 \left[ \int_{-\pi/2}^{-\pi/6} \frac{1}{2} (3 + 2 \sin \theta)^2 \, d\theta + \int_{-\pi/6}^{\pi/2} \frac{1}{2} 2^2 \, d\theta \right]$

$$= \int_{-\pi/2}^{-\pi/6} (9 + 12 \sin \theta + 4 \sin^2 \theta) \, d\theta + [4\theta]_{-\pi/6}^{\pi/2}$$

$$= [9\theta - 12 \cos \theta + 2\theta - \sin 2\theta]_{-\pi/2}^{-\pi/6} + \frac{8\pi}{3} = \frac{19\pi}{3} - \frac{11\sqrt{3}}{2}$$

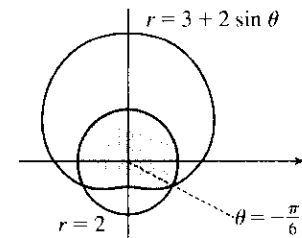

34. Let  $\alpha = \tan^{-1}(b/a)$ . Then

$$A = \int_0^\alpha \frac{1}{2} (a \sin \theta)^2 \, d\theta + \int_\alpha^{\pi/2} \frac{1}{2} (b \cos \theta)^2 \, d\theta$$

$$= \frac{1}{4} a^2 \left[ \theta - \frac{1}{2} \sin 2\theta \right]_0^\alpha + \frac{1}{4} b^2 \left[ \theta + \frac{1}{2} \sin 2\theta \right]_\alpha^{\pi/2}$$

$$= \frac{1}{4} \alpha (a^2 - b^2) + \frac{1}{8} \pi b^2 - \frac{1}{4} (a^2 + b^2) (\sin \alpha \cos \alpha)$$

$$= \frac{1}{4} (a^2 - b^2) \tan^{-1}(b/a) + \frac{1}{8} \pi b^2 - \frac{1}{4} ab$$

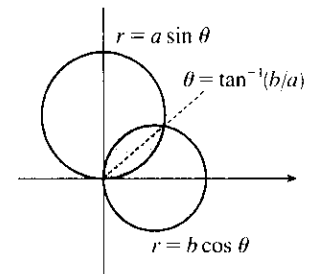

35. The darker shaded region (from  $\theta = 0$  to  $\theta = 2\pi/3$ ) represents  $\frac{1}{2}$  of the desired area plus  $\frac{1}{2}$  of the area of the inner loop. From this area, we'll subtract  $\frac{1}{2}$  of the area of the inner loop (the lighter shaded region from  $\theta = 2\pi/3$  to  $\theta = \pi$ ), and then double that difference to obtain the desired area.

$$\begin{aligned} A &= 2 \left[ \int_0^{2\pi/3} \frac{1}{2} \left( \frac{1}{2} + \cos \theta \right)^2 d\theta - \int_{2\pi/3}^{\pi} \frac{1}{2} \left( \frac{1}{2} + \cos \theta \right)^2 d\theta \right] \\ &= \int_0^{2\pi/3} \left( \frac{1}{4} + \cos \theta + \cos^2 \theta \right) d\theta - \int_{2\pi/3}^{\pi} \left( \frac{1}{4} + \cos \theta + \cos^2 \theta \right) d\theta \\ &= \int_0^{2\pi/3} \left[ \frac{1}{4} + \cos \theta + \frac{1}{2}(1 + \cos 2\theta) \right] d\theta \\ &\quad - \int_{2\pi/3}^{\pi} \left[ \frac{1}{4} + \cos \theta + \frac{1}{2}(1 + \cos 2\theta) \right] d\theta \\ &= \left[ \frac{\theta}{4} + \sin \theta + \frac{\theta}{2} + \frac{\sin 2\theta}{4} \right]_0^{2\pi/3} - \left[ \frac{\theta}{4} + \sin \theta + \frac{\theta}{2} + \frac{\sin 2\theta}{4} \right]_{2\pi/3}^{\pi} \\ &= \left( \frac{\pi}{6} + \frac{\sqrt{3}}{2} + \frac{\pi}{3} - \frac{\sqrt{3}}{8} \right) - \left( \frac{\pi}{4} + \frac{\pi}{2} \right) + \left( \frac{\pi}{6} + \frac{\sqrt{3}}{2} + \frac{\pi}{3} - \frac{\sqrt{3}}{8} \right) \\ &= \frac{\pi}{4} + \frac{3}{4}\sqrt{3} = \frac{1}{4}(\pi + 3\sqrt{3}) \end{aligned}$$

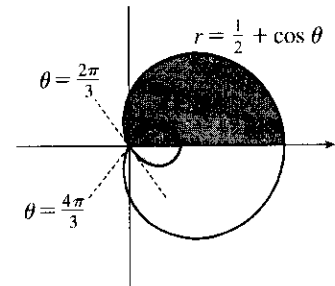

36.  $r = 0 \Rightarrow 1 + 2 \cos 3\theta = 0 \Rightarrow \cos 3\theta = -\frac{1}{2} \Rightarrow 3\theta = \frac{2\pi}{3}, \frac{4\pi}{3}$  (for  $0 \leq 3\theta \leq 2\pi$ )  $\Rightarrow \theta = \frac{2\pi}{9}, \frac{4\pi}{9}$ . The darker shaded region (from  $\theta = 0$  to  $\theta = 2\pi/9$ ) represents  $\frac{1}{2}$  of the desired area plus  $\frac{1}{2}$  of the area of the inner loop. From this area, we'll subtract  $\frac{1}{2}$  of the area of the inner loop (the lighter shaded region from  $\theta = 2\pi/9$  to  $\theta = \pi/3$ ), and then double that difference to obtain the desired area.

$$A = 2 \left[ \int_0^{2\pi/9} \frac{1}{2} (1 + 2 \cos 3\theta)^2 d\theta - \int_{2\pi/9}^{\pi/3} \frac{1}{2} (1 + 2 \cos 3\theta)^2 d\theta \right]$$

Now

$$\begin{aligned} r^2 &= (1 + 2 \cos 3\theta)^2 = 1 + 4 \cos 3\theta + 4 \cos^2 3\theta = 1 + 4 \cos 3\theta + 4 \cdot \frac{1}{2}(1 + \cos 6\theta) \\ &= 1 + 4 \cos 3\theta + 2 + 2 \cos 6\theta = 3 + 4 \cos 3\theta + 2 \cos 6\theta \end{aligned}$$

and  $\int r^2 d\theta = 3\theta + \frac{4}{3} \sin 3\theta + \frac{1}{3} \sin 6\theta + C$ , so

$$\begin{aligned} A &= \left[ 3\theta + \frac{4}{3} \sin 3\theta + \frac{1}{3} \sin 6\theta \right]_0^{2\pi/9} - \left[ 3\theta + \frac{4}{3} \sin 3\theta + \frac{1}{3} \sin 6\theta \right]_{2\pi/9}^{\pi/3} \\ &= \left[ \left( \frac{2\pi}{3} + \frac{4}{3} \cdot \frac{\sqrt{3}}{2} + \frac{1}{3} \cdot \frac{-\sqrt{3}}{2} \right) - 0 \right] - \left[ (\pi + 0 + 0) - \left( \frac{2\pi}{3} + \frac{4}{3} \cdot \frac{\sqrt{3}}{2} + \frac{1}{3} \cdot \frac{-\sqrt{3}}{2} \right) \right] \\ &= \frac{4\pi}{3} + \frac{4}{3}\sqrt{3} - \frac{1}{3}\sqrt{3} - \pi = \frac{\pi}{3} + \sqrt{3} \end{aligned}$$

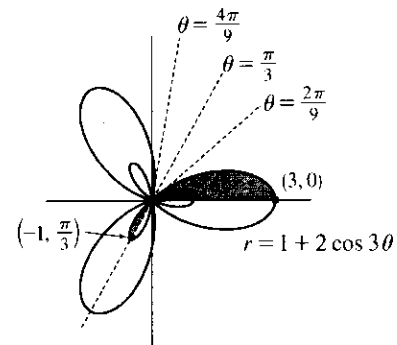

37. The two circles intersect at the pole since  $(0, 0)$  satisfies the first equation and  $(0, \frac{\pi}{2})$  the second. The other intersection point  $(\frac{1}{\sqrt{2}}, \frac{\pi}{4})$  occurs where  $\sin \theta = \cos \theta$ .

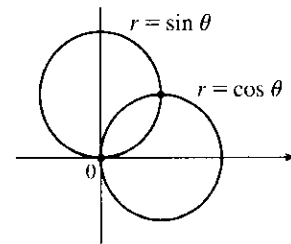

38.  $2 \cos 2\theta = \pm 2 \Rightarrow \cos 2\theta = \pm 1 \Rightarrow \theta = 0, \frac{\pi}{2}, \pi, \text{ or } \frac{3\pi}{2}$ , so the points are  $(2, 0), (2, \frac{\pi}{2}), (2, \pi), \text{ and } (2, \frac{3\pi}{2})$ .

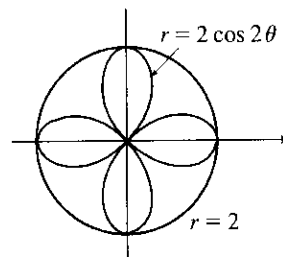

39. The curves intersect at the pole since  $(0, \frac{\pi}{2})$  satisfies  $r = \cos \theta$  and  $(0, 0)$  satisfies  $r = 1 - \cos \theta$ . Now  $\cos \theta = 1 - \cos \theta \Rightarrow 2 \cos \theta = 1 \Rightarrow \cos \theta = \frac{1}{2} \Rightarrow \theta = \frac{\pi}{3} \text{ or } \frac{5\pi}{3} \Rightarrow$  the other intersection points are  $(\frac{1}{2}, \frac{\pi}{3})$  and  $(\frac{1}{2}, \frac{5\pi}{3})$ .

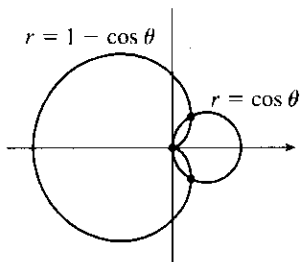

40. Clearly the pole lies on both curves.  $\sin 3\theta = \cos 3\theta \Rightarrow \tan 3\theta = 1 \Rightarrow 3\theta = \frac{\pi}{4} + n\pi$  ( $n$  any integer)  $\Rightarrow \theta = \frac{\pi}{12} + \frac{\pi}{3}n \Rightarrow \theta = \frac{\pi}{12}, \frac{5\pi}{12}, \text{ or } \frac{3\pi}{4}$ , so the three remaining intersection points are  $(\frac{1}{\sqrt{2}}, \frac{\pi}{12}), (-\frac{1}{\sqrt{2}}, \frac{5\pi}{12}), \text{ and } (\frac{1}{\sqrt{2}}, \frac{3\pi}{4})$ .

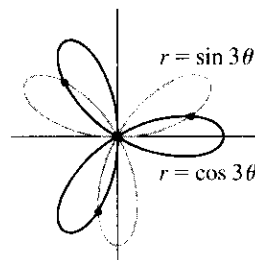

41. The pole is a point of intersection.  $\sin \theta = \sin 2\theta = 2 \sin \theta \cos \theta \Leftrightarrow \sin \theta (1 - 2 \cos \theta) = 0 \Leftrightarrow \sin \theta = 0$  or  $\cos \theta = \frac{1}{2} \Rightarrow \theta = 0, \pi, \frac{\pi}{3}, -\frac{\pi}{3} \Rightarrow (\frac{\sqrt{3}}{2}, \frac{\pi}{3})$  and  $(\frac{\sqrt{3}}{2}, \frac{2\pi}{3})$  (by symmetry) are the other intersection points.

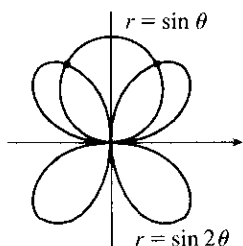

42. Clearly the pole is a point of intersection.  $\sin 2\theta = \cos 2\theta \Rightarrow \tan 2\theta = 1 \Rightarrow 2\theta = \frac{\pi}{4} + 2n\pi$  (since  $\sin 2\theta$  and  $\cos 2\theta$  must be positive in the equations)  $\Rightarrow \theta = \frac{\pi}{8} + n\pi \Rightarrow \theta = \frac{\pi}{8}$  or  $\frac{9\pi}{8}$ . So the curves also intersect at  $(\frac{1}{\sqrt{2}}, \frac{\pi}{8})$  and  $(\frac{1}{\sqrt{2}}, \frac{9\pi}{8})$ .

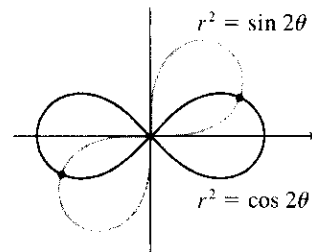

43.

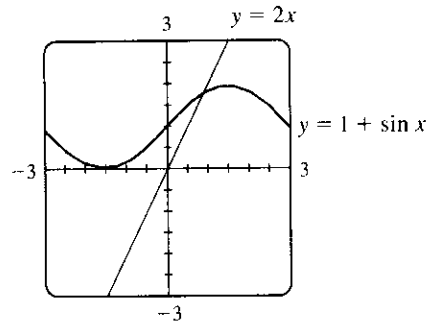
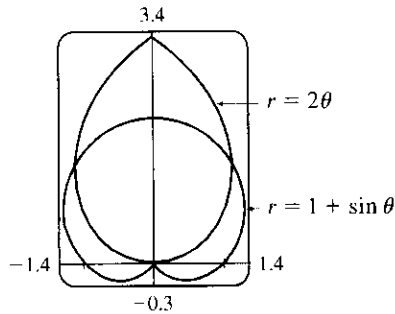

From the first graph, we see that the pole is one point of intersection. By zooming in or using the cursor, we find the  $\theta$ -values of the intersection points to be  $\alpha \approx 0.88786 \approx 0.89$  and  $\pi - \alpha \approx 2.25$ . (The first of these values may be more easily estimated by plotting  $y = 1 + \sin x$  and  $y = 2x$  in rectangular coordinates; see the second graph.)

By symmetry, the total area contained is twice the area contained in the first quadrant, that is,

$$\begin{aligned} A &= 2 \int_0^\alpha \frac{1}{2} (2\theta)^2 d\theta + 2 \int_\alpha^{\pi/2} \frac{1}{2} (1 + \sin \theta)^2 d\theta = \int_0^\alpha 4\theta^2 d\theta + \int_\alpha^{\pi/2} [1 + 2\sin \theta + \frac{1}{2}(1 - \cos 2\theta)] d\theta \\ &= \left[ \frac{4}{3}\theta^3 \right]_0^\alpha + \left[ \theta - 2\cos \theta + \left( \frac{1}{2}\theta - \frac{1}{4}\sin 2\theta \right) \right]_\alpha^{\pi/2} \\ &= \frac{4}{3}\alpha^3 + \left[ \left( \frac{\pi}{2} + \frac{\pi}{4} \right) - \left( \alpha - 2\cos \alpha + \frac{1}{2}\alpha - \frac{1}{4}\sin 2\alpha \right) \right] \approx 3.4645 \end{aligned}$$

44.

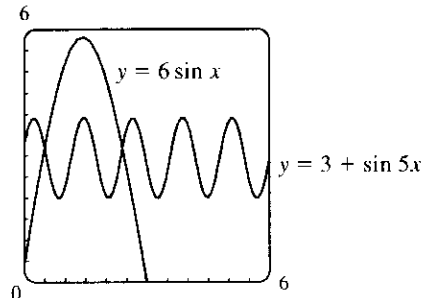
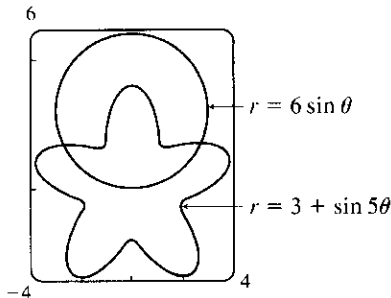

From the first graph, it appears that the  $\theta$ -values of the points of intersection are  $\alpha \approx 0.57504 \approx 0.58$  and  $\pi - \alpha \approx 2.57$ . (These values may be more easily estimated by plotting  $y = 3 + \sin 5x$  and  $y = 6 \sin x$  in rectangular coordinates; see the second graph.) By symmetry, the total area enclosed in both curves is

$$\begin{aligned} A &= 2 \int_0^\alpha \frac{1}{2} (6 \sin \theta)^2 d\theta + 2 \int_\alpha^{\pi/2} \frac{1}{2} (3 + \sin 5\theta)^2 d\theta = \int_0^\alpha 36 \sin^2 \theta d\theta + \int_\alpha^{\pi/2} (9 + 6 \sin 5\theta + \sin^2 5\theta) d\theta \\ &= \int_0^\alpha 36 \cdot \frac{1}{2} (1 - \cos 2\theta) d\theta + \int_\alpha^{\pi/2} \left[ 9 + 6 \sin 5\theta + \frac{1}{2} (1 - \cos 10\theta) \right] d\theta \\ &= \left[ 36 \left( \frac{1}{2}\theta - \frac{1}{4}\sin 2\theta \right) \right]_0^\alpha + \left[ 9\theta - \frac{6}{5}\cos 5\theta + \left( \frac{1}{2}\theta - \frac{1}{20}\sin 10\theta \right) \right]_\alpha^{\pi/2} \approx 10.41 \end{aligned}$$

$$\begin{aligned} 45. L &= \int_a^b \sqrt{r^2 + (dr/d\theta)^2} d\theta = \int_0^{\pi/3} \sqrt{(3 \sin \theta)^2 + (3 \cos \theta)^2} d\theta = \int_0^{\pi/3} \sqrt{9(\sin^2 \theta + \cos^2 \theta)} d\theta \\ &= 3 \int_0^{\pi/3} d\theta = 3[\theta]_0^{\pi/3} = 3\left(\frac{\pi}{3}\right) = \pi. \end{aligned}$$

As a check, note that the circumference of a circle with radius  $\frac{3}{2}$  is  $2\pi\left(\frac{3}{2}\right) = 3\pi$ , and since  $\theta = 0$  to  $\theta = \pi$  traces out  $\frac{1}{3}$  of the circle (from  $\theta = 0$  to  $\theta = \pi$ ),  $\frac{1}{3}(3\pi) = \pi$ .



$$46. L = \int_a^b \sqrt{r^2 + (dr/d\theta)^2} d\theta = \int_0^{2\pi} \sqrt{(e^{2\theta})^2 + (2e^{2\theta})^2} d\theta = \int_0^{2\pi} \sqrt{e^{4\theta} + 4e^{4\theta}} d\theta = \int_0^{2\pi} \sqrt{5e^{4\theta}} d\theta$$

$$= \sqrt{5} \int_0^{2\pi} e^{2\theta} d\theta = \frac{\sqrt{5}}{2} [e^{2\theta}]_0^{2\pi} = \frac{\sqrt{5}}{2} (e^{4\pi} - 1)$$

$$47. L = \int_a^b \sqrt{r^2 + (dr/d\theta)^2} d\theta = \int_0^{2\pi} \sqrt{(\theta^2)^2 + (2\theta)^2} d\theta = \int_0^{2\pi} \sqrt{\theta^4 + 4\theta^2} d\theta$$

$$= \int_0^{2\pi} \sqrt{\theta^2(\theta^2 + 4)} d\theta = \int_0^{2\pi} \theta \sqrt{\theta^2 + 4} d\theta$$

Now let  $u = \theta^2 + 4$ , so that  $du = 2\theta d\theta$  [ $\theta d\theta = \frac{1}{2} du$ ] and

$$\int_0^{2\pi} \theta \sqrt{\theta^2 + 4} d\theta = \int_4^{4\pi^2 + 4} \frac{1}{2} \sqrt{u} du = \frac{1}{2} \cdot \frac{2}{3} [u^{3/2}]_4^{4\pi^2 + 4} = \frac{1}{3} [4^{3/2}(\pi^2 + 1)^{3/2} - 4^{3/2}]$$

$$= \frac{8}{3} [(\pi^2 + 1)^{3/2} - 1]$$

$$48. L = \int_a^b \sqrt{r^2 + (dr/d\theta)^2} d\theta = \int_0^{2\pi} \sqrt{\theta^2 + 1} d\theta \stackrel{21}{=} \left[ \frac{\theta}{2} \sqrt{\theta^2 + 1} + \frac{1}{2} \ln(\theta + \sqrt{\theta^2 + 1}) \right]_0^{2\pi}$$

$$= \pi \sqrt{4\pi^2 + 1} + \frac{1}{2} \ln(2\pi + \sqrt{4\pi^2 + 1})$$

49. The curve  $r = 3 \sin 2\theta$  is completely traced with  $0 \leq \theta \leq 2\pi$ .

$$r^2 + \left(\frac{dr}{d\theta}\right)^2 = (3 \sin 2\theta)^2 + (6 \cos 2\theta)^2 \Rightarrow$$

$$L = \int_0^{2\pi} \sqrt{9 \sin^2 2\theta + 36 \cos^2 2\theta} d\theta \approx 29.0653$$

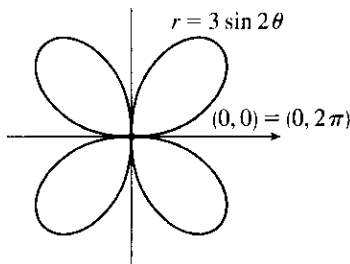

50. The curve  $r = 4 \sin 3\theta$  is completely traced with  $0 \leq \theta \leq \pi$ .

$$r^2 + \left(\frac{dr}{d\theta}\right)^2 = (4 \sin 3\theta)^2 + (12 \cos 3\theta)^2 \Rightarrow$$

$$L = \int_0^{\pi} \sqrt{16 \sin^2 3\theta + 144 \cos^2 3\theta} d\theta \approx 26.7298$$

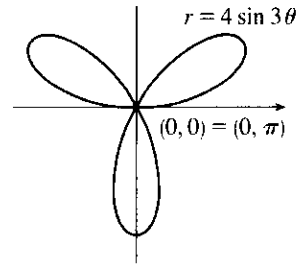

51. The curve  $r = \sin(\frac{\theta}{2})$  is completely traced with  $0 \leq \theta \leq 4\pi$ .

$$r^2 + \left(\frac{dr}{d\theta}\right)^2 = \sin^2\left(\frac{\theta}{2}\right) + \left[\frac{1}{2} \cos\left(\frac{\theta}{2}\right)\right]^2 \Rightarrow$$

$$L = \int_0^{4\pi} \sqrt{\sin^2\left(\frac{\theta}{2}\right) + \frac{1}{4} \cos^2\left(\frac{\theta}{2}\right)} d\theta$$

$$\approx 9.6884$$

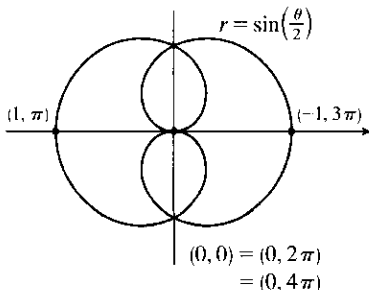

52. The curve  $r = 1 + \cos(\frac{\theta}{3})$  is completely traced with  $0 \leq \theta \leq 6\pi$ .

$$r^2 + \left(\frac{dr}{d\theta}\right)^2 = \left[1 + \cos\left(\frac{\theta}{3}\right)\right]^2 + \left[-\frac{1}{3} \sin\left(\frac{\theta}{3}\right)\right]^2 \Rightarrow$$

$$L = \int_0^{6\pi} \sqrt{\left[1 + \cos\left(\frac{\theta}{3}\right)\right]^2 + \frac{1}{9} \sin^2\left(\frac{\theta}{3}\right)} d\theta$$

$$\approx 19.6676$$

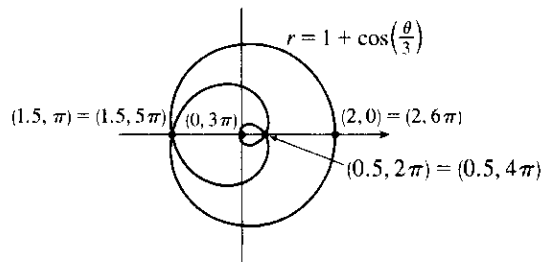

53. The curve  $r = \cos^4(\theta/4)$  is completely traced with  $0 \leq \theta \leq 4\pi$ .

$$\begin{aligned} r^2 + (dr/d\theta)^2 &= [\cos^4(\theta/4)]^2 + [4\cos^3(\theta/4) \cdot (-\sin(\theta/4)) \cdot \frac{1}{4}]^2 \\ &= \cos^8(\theta/4) + \cos^6(\theta/4) \sin^2(\theta/4) \\ &= \cos^6(\theta/4) [\cos^2(\theta/4) + \sin^2(\theta/4)] \\ &= \cos^6(\theta/4) \end{aligned}$$

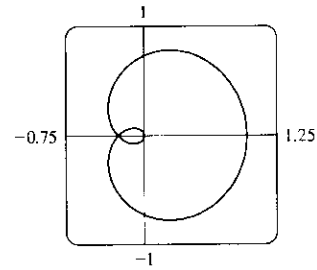

$$\begin{aligned} L &= \int_0^{4\pi} \sqrt{\cos^6(\theta/4)} d\theta = \int_0^{4\pi} |\cos^3(\theta/4)| d\theta \\ &= 2 \int_0^{2\pi} \cos^3(\theta/4) d\theta \quad [\text{since } \cos^3(\theta/4) \geq 0 \text{ for } 0 \leq \theta \leq 2\pi] = 8 \int_0^{\pi/2} \cos^3 u du \quad [u = \frac{1}{4}\theta] \\ &\stackrel{68}{=} 8 \left[ \frac{1}{3}(2 + \cos^2 u) \sin u \right]_0^{\pi/2} = \frac{8}{3} [(2 \cdot 1) - (3 \cdot 0)] = \frac{16}{3} \end{aligned}$$

54. The curve  $r = \cos^2(\theta/2)$  is completely traced with  $0 \leq \theta \leq 2\pi$ .

$$\begin{aligned} r^2 + (dr/d\theta)^2 &= [\cos^2(\theta/2)]^2 + [2\cos(\theta/2) \cdot (-\sin(\theta/2)) \cdot \frac{1}{2}]^2 \\ &= \cos^4(\theta/2) + \cos^2(\theta/2) \sin^2(\theta/2) \\ &= \cos^2(\theta/2) [\cos^2(\theta/2) + \sin^2(\theta/2)] \\ &= \cos^2(\theta/2) \end{aligned}$$

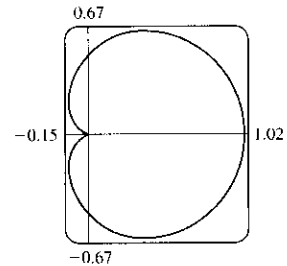

$$\begin{aligned} L &= \int_0^{2\pi} \sqrt{\cos^2(\theta/2)} d\theta = \int_0^{2\pi} |\cos(\theta/2)| d\theta = 2 \int_0^{\pi} \cos(\theta/2) d\theta \quad [\text{since } \cos(\theta/2) \geq 0 \text{ for } 0 \leq \theta \leq \pi] \\ &= 4 \int_0^{\pi/2} \cos u du \quad [u = \frac{1}{2}\theta] = 4[\sin u]_0^{\pi/2} = 4(1 - 0) = 4 \end{aligned}$$

55. (a) From (11.2.7),

$$\begin{aligned} S &= \int_a^b 2\pi y \sqrt{(dx/d\theta)^2 + (dy/d\theta)^2} d\theta \\ &= \int_a^b 2\pi y \sqrt{r^2 + (dr/d\theta)^2} d\theta \quad [\text{from the derivation of Equation 11.4.5}] \\ &= \int_a^b 2\pi r \sin \theta \sqrt{r^2 + (dr/d\theta)^2} d\theta \end{aligned}$$

- (b) The curve  $r^2 = \cos 2\theta$  goes through the pole when

$$\cos 2\theta = 0 \Rightarrow 2\theta = \frac{\pi}{2} \Rightarrow \theta = \frac{\pi}{4}. \text{ We'll rotate the curve}$$

from  $\theta = 0$  to  $\theta = \frac{\pi}{4}$  and double this value to obtain the total surface

$$\text{area generated. } r^2 = \cos 2\theta \Rightarrow 2r \frac{dr}{d\theta} = -2 \sin 2\theta \Rightarrow$$

$$\left(\frac{dr}{d\theta}\right)^2 = \frac{\sin^2 2\theta}{r^2} = \frac{\sin^2 2\theta}{\cos 2\theta}.$$

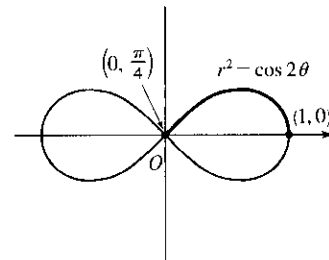

$$\begin{aligned} S &= 2 \int_0^{\pi/4} 2\pi \sqrt{\cos 2\theta} \sin \theta \sqrt{\cos 2\theta + (\sin^2 2\theta)/\cos 2\theta} d\theta \\ &= 4\pi \int_0^{\pi/4} \sqrt{\cos 2\theta} \sin \theta \sqrt{\frac{\cos^2 2\theta + \sin^2 2\theta}{\cos 2\theta}} d\theta = 4\pi \int_0^{\pi/4} \sqrt{\cos 2\theta} \sin \theta \frac{1}{\sqrt{\cos 2\theta}} d\theta \\ &= 4\pi \int_0^{\pi/4} \sin \theta d\theta = 4\pi [-\cos \theta]_0^{\pi/4} = -4\pi \left(\frac{\sqrt{2}}{2} - 1\right) = 2\pi(2 - \sqrt{2}) \end{aligned}$$

56. (a) Rotation around  $\theta = \frac{\pi}{2}$  is the same as rotation around the  $y$ -axis, that is,  $S = \int_a^b 2\pi x ds$  where  $ds = \sqrt{(dx/dt)^2 + (dy/dt)^2} dt$  for a parametric equation, and for the special case of a polar equation,  $x = r \cos \theta$  and  $ds = \sqrt{(dx/d\theta)^2 + (dy/d\theta)^2} d\theta = \sqrt{r^2 + (dr/d\theta)^2} d\theta$  [see the derivation of Equation 11.4.5]. Therefore, for a polar equation rotated around  $\theta = \frac{\pi}{2}$ ,  $S = \int_a^b 2\pi r \cos \theta \sqrt{r^2 + (dr/d\theta)^2} d\theta$ .
- (b) As in the solution for Exercise 55(b), we can double the surface area generated by rotating the curve from  $\theta = 0$  to  $\theta = \frac{\pi}{4}$  to obtain the total surface area.

$$\begin{aligned} S &= 2 \int_0^{\pi/4} 2\pi \sqrt{\cos 2\theta} \cos \theta \sqrt{\cos 2\theta + (\sin^2 2\theta)/\cos 2\theta} d\theta \\ &= 4\pi \int_0^{\pi/4} \sqrt{\cos 2\theta} \cos \theta \sqrt{\frac{\cos^2 2\theta + \sin^2 2\theta}{\cos 2\theta}} d\theta \\ &= 4\pi \int_0^{\pi/4} \sqrt{\cos 2\theta} \cos \theta \frac{1}{\sqrt{\cos 2\theta}} d\theta \\ &= 4\pi \int_0^{\pi/4} \cos \theta d\theta = 4\pi [\sin \theta]_0^{\pi/4} = 4\pi \left( \frac{\sqrt{2}}{2} - 0 \right) = 2\sqrt{2}\pi \end{aligned}$$

## 11.5 Conic Sections

1.  $x = 2y^2 \Rightarrow y^2 = \frac{1}{2}x$ .  $4p = \frac{1}{2}$ , so  $p = \frac{1}{8}$ . The vertex is  $(0, 0)$ , the focus is  $(\frac{1}{8}, 0)$ , and the directrix is  $x = -\frac{1}{8}$ .

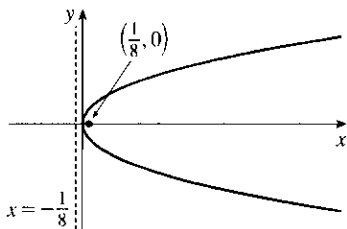

2.  $4y + x^2 = 0 \Rightarrow x^2 = -4y$ .  $4p = -4$ , so  $p = -1$ . The vertex is  $(0, 0)$ , the focus is  $(0, -1)$ , and the directrix is  $y = 1$ .

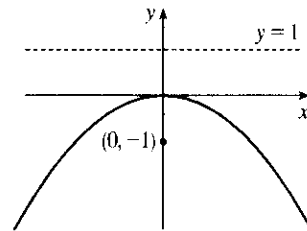

3.  $4x^2 = -y \Rightarrow x^2 = -\frac{1}{4}y$ .  $4p = -\frac{1}{4}$ , so  $p = -\frac{1}{16}$ . The vertex is  $(0, 0)$ , the focus is  $(0, -\frac{1}{16})$ , and the directrix is  $y = \frac{1}{16}$ .

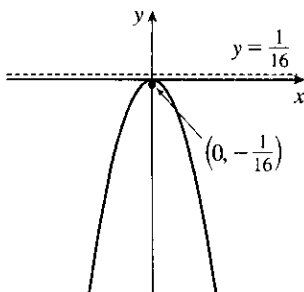

4.  $y^2 = 12x$ .  $4p = 12$ , so  $p = 3$ . The vertex is  $(0, 0)$ , the focus is  $(3, 0)$ , and the directrix is  $x = -3$ .

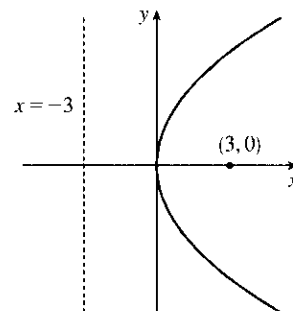

5.  $(x + 2)^2 = 8(y - 3)$ .  $4p = 8$ , so  $p = 2$ . The vertex is  $(-2, 3)$ , the focus is  $(-2, 5)$ , and the directrix is  $y = 1$ .

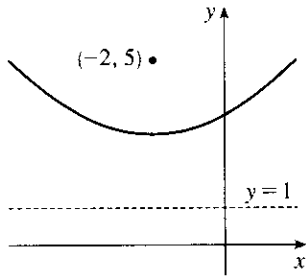

6.  $x - 1 = (y + 5)^2$ .  $4p = 1$ , so  $p = \frac{1}{4}$ . The vertex is  $(1, -5)$ , the focus is  $(\frac{5}{4}, -5)$ , and the directrix is  $x = \frac{3}{4}$ .

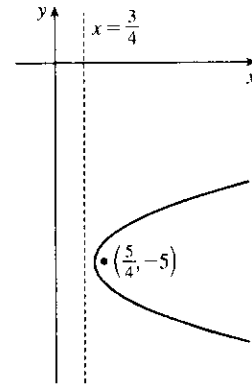

7.  $y^2 + 2y + 12x + 25 = 0 \Rightarrow$   
 $y^2 + 2y + 1 = -12x - 24 \Rightarrow$   
 $(y + 1)^2 = -12(x + 2)$ .  $4p = -12$ , so  $p = -3$ .  
 The vertex is  $(-2, -1)$ , the focus is  $(-5, -1)$ , and the directrix is  $x = 1$ .

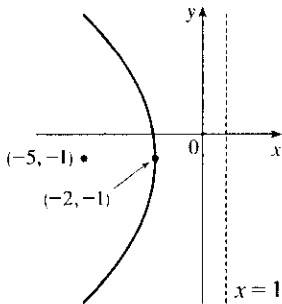

8.  $y + 12x - 2x^2 = 16 \Rightarrow$   
 $2x^2 - 12x = y - 16 \Rightarrow$   
 $2(x^2 - 6x + 9) = y - 16 + 18 \Rightarrow$   
 $2(x - 3)^2 = y + 2 \Rightarrow (x - 3)^2 = \frac{1}{2}(y + 2)$ .  
 $4p = \frac{1}{2}$ , so  $p = \frac{1}{8}$ . The vertex is  $(3, -2)$ , the focus is  $(3, -\frac{15}{8})$ , and the directrix is  $y = -\frac{17}{8}$ .

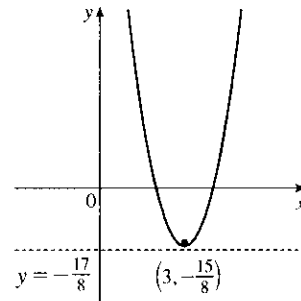

9. The equation has the form  $y^2 = 4px$ , where  $p < 0$ . Since the parabola passes through  $(-1, 1)$ , we have  $1^2 = 4p(-1)$ , so  $4p = -1$  and an equation is  $y^2 = -x$  or  $x = -y^2$ .  $4p = -1$ , so  $p = -\frac{1}{4}$  and the focus is  $(-\frac{1}{4}, 0)$  while the directrix is  $x = \frac{1}{4}$ .

10. The vertex is  $(2, -2)$ , so the equation is of the form  $(x - 2)^2 = 4p(y + 2)$ , where  $p > 0$ . The point  $(0, 0)$  is on the parabola, so  $4 = 4p(2)$  and  $4p = 2$ . Thus, an equation is  $(x - 2)^2 = 2(y + 2)$ .  $4p = 2$ , so  $p = \frac{1}{2}$  and the focus is  $(2, -\frac{3}{2})$  while the directrix is  $y = -\frac{5}{2}$ .

11.  $\frac{x^2}{9} + \frac{y^2}{5} = 1 \Rightarrow a = \sqrt{9} = 3, b = \sqrt{5},$   
 $c = \sqrt{a^2 - b^2} = \sqrt{9 - 5} = 2.$  The ellipse is centered at  $(0, 0),$  with vertices at  $(\pm 3, 0).$  The foci are  $(\pm 2, 0).$

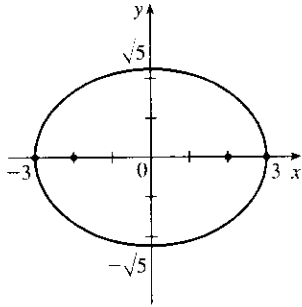

12.  $\frac{x^2}{64} + \frac{y^2}{100} = 1 \Rightarrow a = \sqrt{100} = 10,$   
 $b = \sqrt{64} = 8, c = \sqrt{a^2 - b^2} = \sqrt{100 - 64} = 6.$   
 The ellipse is centered at  $(0, 0),$  with vertices at  $(0, \pm 10).$  The foci are  $(0, \pm 6).$

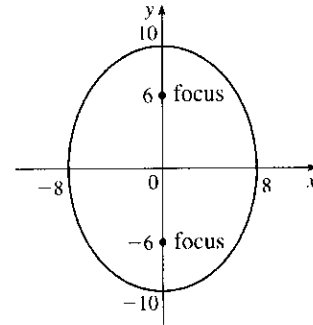

13.  $4x^2 + y^2 = 16 \Rightarrow \frac{x^2}{4} + \frac{y^2}{16} = 1 \Rightarrow$   
 $a = \sqrt{16} = 4, b = \sqrt{4} = 2,$   
 $c = \sqrt{a^2 - b^2} = \sqrt{16 - 4} = 2\sqrt{3}.$  The ellipse is centered at  $(0, 0),$  with vertices at  $(0, \pm 4).$  The foci are  $(0, \pm 2\sqrt{3}).$

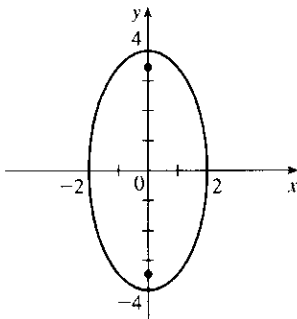

14.  $4x^2 + 25y^2 = 25 \Rightarrow \frac{x^2}{25/4} + \frac{y^2}{1} = 1 \Rightarrow$   
 $a = \sqrt{\frac{25}{4}} = \frac{5}{2}, b = \sqrt{1} = 1,$   
 $c = \sqrt{a^2 - b^2} = \sqrt{\frac{25}{4} - 1} = \sqrt{\frac{21}{4}} = \frac{\sqrt{21}}{2}.$  The ellipse is centered at  $(0, 0),$  with vertices at  $(\pm \frac{5}{2}, 0).$  The foci are  $(\pm \frac{\sqrt{21}}{2}, 0).$

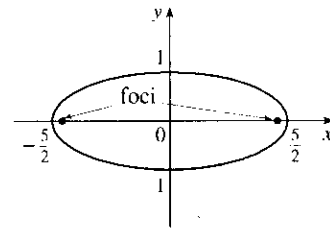

15.  $9x^2 - 18x + 4y^2 = 27 \Leftrightarrow 9(x^2 - 2x + 1) + 4y^2 = 27 + 9 \Leftrightarrow$   
 $9(x - 1)^2 + 4y^2 = 36 \Leftrightarrow \frac{(x - 1)^2}{4} + \frac{y^2}{9} = 1 \Rightarrow a = 3, b = 2,$   
 $c = \sqrt{5} \Rightarrow$  center  $(1, 0),$  vertices  $(1, \pm 3),$  foci  $(1, \pm \sqrt{5})$

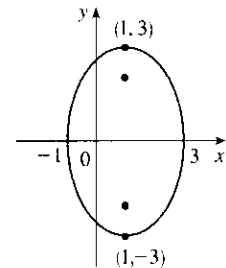

16.  $x^2 - 6x + 2y^2 + 4y = -7 \Leftrightarrow$   
 $x^2 - 6x + 9 + 2(y^2 + 2y + 1) = -7 + 9 + 2 \Leftrightarrow$   
 $(x - 3)^2 + 2(y + 1)^2 = 4 \Leftrightarrow$   
 $\frac{(x - 3)^2}{4} + \frac{(y + 1)^2}{2} = 1 \Rightarrow a = 2, b = \sqrt{2} = c \Rightarrow$  center  
 $(3, -1),$  vertices  $(1, -1)$  and  $(5, -1),$  foci  $(3 \pm \sqrt{2}, -1)$

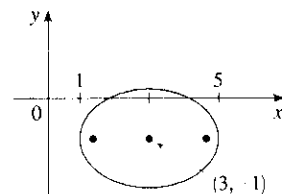

17. The center is  $(0, 0)$ ,  $a = 3$ , and  $b = 2$ , so an equation is  $\frac{x^2}{4} + \frac{y^2}{9} = 1$ .  $c = \sqrt{a^2 - b^2} = \sqrt{5}$ , so the foci are  $(0, \pm\sqrt{5})$ .

18. The ellipse is centered at  $(2, 1)$ , with  $a = 3$  and  $b = 2$ . An equation is  $\frac{(x-2)^2}{9} + \frac{(y-1)^2}{4} = 1$ .  
 $c = \sqrt{a^2 - b^2} = \sqrt{5}$ , so the foci are  $(2 \pm \sqrt{5}, 1)$ .

19.  $\frac{x^2}{144} - \frac{y^2}{25} = 1 \Rightarrow a = 12, b = 5, c = \sqrt{144 + 25} = 13 \Rightarrow$   
 center  $(0, 0)$ , vertices  $(\pm 12, 0)$ , foci  $(\pm 13, 0)$ ,  
 asymptotes  $y = \pm \frac{5}{12}x$ .

*Note:* It is helpful to draw a  $2a$ -by- $2b$  rectangle whose center is the center of the hyperbola. The asymptotes are the extended diagonals of the rectangle.

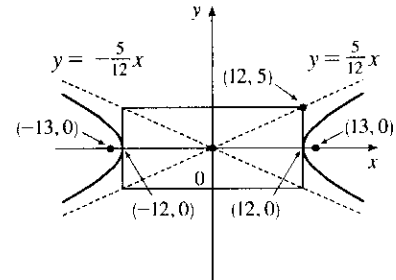

20.  $\frac{y^2}{16} - \frac{x^2}{36} = 1 \Rightarrow a = 4, b = 6,$   
 $c = \sqrt{a^2 + b^2} = \sqrt{16 + 36} = \sqrt{52} = 2\sqrt{13}$ . The center is  $(0, 0)$ ,  
 the vertices are  $(0, \pm 4)$ , the foci are  $(0, \pm 2\sqrt{13})$ , and the  
 asymptotes are the lines  $y = \pm \frac{a}{b}x = \pm \frac{2}{3}x$ .

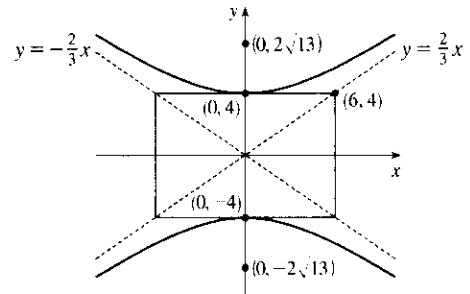

21.  $y^2 - x^2 = 4 \Leftrightarrow \frac{y^2}{4} - \frac{x^2}{4} = 1 \Rightarrow a = \sqrt{4} = 2 = b,$   
 $c = \sqrt{4 + 4} = 2\sqrt{2} \Rightarrow$  center  $(0, 0)$ , vertices  $(0, \pm 2)$ ,  
 foci  $(0, \pm 2\sqrt{2})$ , asymptotes  $y = \pm x$

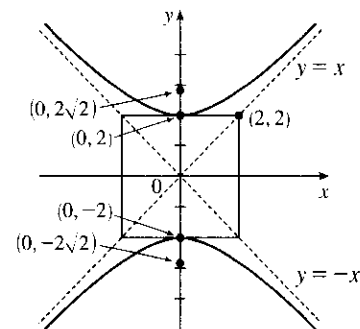

22.  $9x^2 - 4y^2 = 36 \Leftrightarrow \frac{x^2}{4} - \frac{y^2}{9} = 1 \Rightarrow a = \sqrt{4} = 2,$   
 $b = \sqrt{9} = 3, c = \sqrt{4 + 9} = \sqrt{13} \Rightarrow$  center  $(0, 0)$ ,  
 vertices  $(\pm 2, 0)$ , foci  $(\pm\sqrt{13}, 0)$ , asymptotes  $y = \pm \frac{3}{2}x$

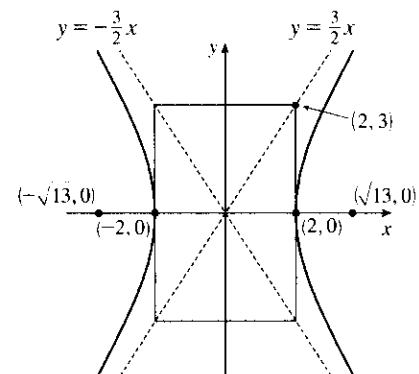

$$\begin{aligned}
 23. \quad & 2y^2 - 4y - 3x^2 + 12x = -8 \Leftrightarrow \\
 & 2(y^2 - 2y + 1) - 3(x^2 - 4x + 4) = -8 + 2 - 12 \Leftrightarrow \\
 & 2(y - 1)^2 - 3(x - 2)^2 = -18 \Leftrightarrow \frac{(x - 2)^2}{6} - \frac{(y - 1)^2}{9} = 1 \\
 & \Rightarrow a = \sqrt{6}, b = 3, c = \sqrt{15} \Rightarrow \text{center } (2, 1), \text{ vertices} \\
 & (2 \pm \sqrt{6}, 1), \text{ foci } (2 \pm \sqrt{15}, 1), \text{ asymptotes } y - 1 = \pm \frac{3}{\sqrt{6}}(x - 2) \\
 & \text{or } y - 1 = \pm \frac{\sqrt{6}}{2}(x - 2)
 \end{aligned}$$

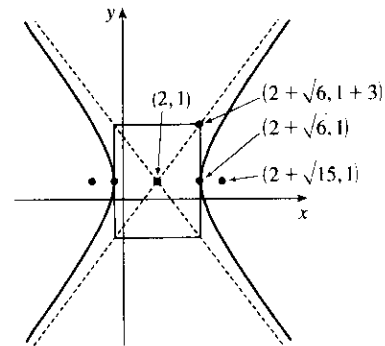

$$\begin{aligned}
 24. \quad & 16x^2 + 64x - 9y^2 - 90y = 305 \Leftrightarrow \\
 & 16(x^2 + 4x + 4) - 9(y^2 + 10y + 25) = 305 + 64 - 225 \Leftrightarrow \\
 & 16(x + 2)^2 - 9(y + 5)^2 = 144 \Leftrightarrow \frac{(x + 2)^2}{9} - \frac{(y + 5)^2}{16} = 1 \\
 & \Rightarrow a = 3, b = 4, c = 5 \Rightarrow \text{center } (-2, -5), \text{ vertices } (-5, -5) \\
 & \text{and } (1, -5), \text{ foci } (-7, -5) \text{ and } (3, -5), \text{ asymptotes} \\
 & y + 5 = \pm \frac{4}{3}(x + 2)
 \end{aligned}$$

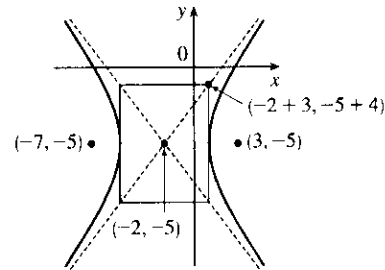

$$25. \quad x^2 = y + 1 \Leftrightarrow x^2 = 1(y + 1). \text{ This is an equation of a parabola with } 4p = 1, \text{ so } p = \frac{1}{4}. \text{ The vertex is } (0, -1) \text{ and the focus is } (0, -\frac{3}{4}).$$

$$26. \quad x^2 = y^2 + 1 \Leftrightarrow x^2 - y^2 = 1. \text{ This is an equation of a hyperbola with vertices } (\pm 1, 0). \text{ The foci are at } (\pm\sqrt{1+1}, 0) = (\pm\sqrt{2}, 0).$$

$$\begin{aligned}
 27. \quad & x^2 = 4y - 2y^2 \Leftrightarrow x^2 + 2y^2 - 4y = 0 \Leftrightarrow x^2 + 2(y^2 - 2y + 1) = 2 \Leftrightarrow x^2 + 2(y - 1)^2 = 2 \Leftrightarrow \\
 & \frac{x^2}{2} + \frac{(y - 1)^2}{1} = 1. \text{ This is an equation of an ellipse with vertices at } (\pm\sqrt{2}, 1). \text{ The foci are at} \\
 & (\pm\sqrt{2-1}, 1) = (\pm 1, 1).
 \end{aligned}$$

$$28. \quad y^2 - 8y = 6x - 16 \Leftrightarrow y^2 - 8y + 16 = 6x \Leftrightarrow (y - 4)^2 = 6x. \text{ This is an equation of a parabola with } 4p = 6, \text{ so } p = \frac{3}{2}. \text{ The vertex is } (0, 4) \text{ and the focus is } (\frac{3}{2}, 4).$$

$$\begin{aligned}
 29. \quad & y^2 + 2y = 4x^2 + 3 \Leftrightarrow y^2 + 2y + 1 = 4x^2 + 4 \Leftrightarrow (y + 1)^2 - 4x^2 = 4 \Leftrightarrow \frac{(y + 1)^2}{4} - x^2 = 1. \text{ This is} \\
 & \text{an equation of a hyperbola with vertices } (0, -1 \pm 2) = (0, 1) \text{ and } (0, -3). \text{ The foci are at} \\
 & (0, -1 \pm \sqrt{4+1}) = (0, -1 \pm \sqrt{5}).
 \end{aligned}$$

$$\begin{aligned}
 30. \quad & 4x^2 + 4x + y^2 = 0 \Leftrightarrow 4(x^2 + x + \frac{1}{4}) + y^2 = 1 \Leftrightarrow 4(x + \frac{1}{2})^2 + y^2 = 1 \Leftrightarrow \frac{(x + \frac{1}{2})^2}{1/4} + y^2 = 1. \text{ This} \\
 & \text{is an equation of an ellipse with vertices } (-\frac{1}{2}, 0 \pm 1) = (-\frac{1}{2}, \pm 1). \text{ The foci are at} \\
 & (-\frac{1}{2}, 0 \pm \sqrt{1 - \frac{1}{4}}) = (-\frac{1}{2}, \pm \sqrt{3}/2).
 \end{aligned}$$

$$31. \quad \text{The parabola with vertex } (0, 0) \text{ and focus } (0, -2) \text{ opens downward and has } p = -2, \text{ so its equation is } x^2 = 4py = -8y.$$

$$32. \quad \text{The parabola with vertex } (1, 0) \text{ and directrix } x = -5 \text{ opens to the right and has } p = 6, \text{ so its equation is } y^2 = 4p(x - 1) = 24(x - 1).$$

33. The distance from the focus  $(-4, 0)$  to the directrix  $x = 2$  is  $2 - (-4) = 6$ , so the distance from the focus to the vertex is  $\frac{1}{2}(6) = 3$  and the vertex is  $(-1, 0)$ . Since the focus is to the left of the vertex,  $p = -3$ . An equation is  $y^2 = 4p(x + 1) \Rightarrow y^2 = -12(x + 1)$ .
34. The distance from the focus  $(3, 6)$  to the vertex  $(3, 2)$  is  $6 - 2 = 4$ . Since the focus is above the vertex,  $p = 4$ . An equation is  $(x - 3)^2 = 4p(y - 2) \Rightarrow (x - 3)^2 = 16(y - 2)$ .
35. The parabola must have equation  $y^2 = 4px$ , so  $(-4)^2 = 4p(1) \Rightarrow p = 4 \Rightarrow y^2 = 16x$ .
36. Vertical axis  $\Rightarrow (x - h)^2 = 4p(y - k)$ . Substituting  $(-2, 3)$  and  $(0, 3)$  gives  $(-2 - h)^2 = 4p(3 - k)$  and  $(-h)^2 = 4p(3 - k) \Rightarrow (-2 - h)^2 = (-h)^2 \Rightarrow 4 + 4h + h^2 = h^2 \Rightarrow h = -1 \Rightarrow 1 = 4p(3 - k)$ . Substituting  $(1, 9)$  gives  $[1 - (-1)]^2 = 4p(9 - k) \Rightarrow 4 = 4p(9 - k)$ . Solving for  $p$  from these equations gives  $p = \frac{1}{4(3 - k)} = \frac{1}{9 - k} \Rightarrow 4(3 - k) = 9 - k \Rightarrow k = 1 \Rightarrow p = \frac{1}{8} \Rightarrow (x + 1)^2 = \frac{1}{2}(y - 1) \Rightarrow 2x^2 + 4x - y + 3 = 0$ .
37. The ellipse with foci  $(\pm 2, 0)$  and vertices  $(\pm 5, 0)$  has center  $(0, 0)$  and a horizontal major axis, with  $a = 5$  and  $c = 2$ , so  $b = \sqrt{a^2 - c^2} = \sqrt{21}$ . An equation is  $\frac{x^2}{25} + \frac{y^2}{21} = 1$ .
38. The ellipse with foci  $(0, \pm 5)$  and vertices  $(0, \pm 13)$  has center  $(0, 0)$  and a vertical major axis, with  $c = 5$  and  $a = 13$ , so  $b = \sqrt{a^2 - c^2} = 12$ . An equation is  $\frac{x^2}{144} + \frac{y^2}{169} = 1$ .
39. Since the vertices are  $(0, 0)$  and  $(0, 8)$ , the ellipse has center  $(0, 4)$  with a vertical axis and  $a = 4$ . The foci at  $(0, 2)$  and  $(0, 6)$  are 2 units from the center, so  $c = 2$  and  $b = \sqrt{a^2 - c^2} = \sqrt{4^2 - 2^2} = \sqrt{12}$ . An equation is  $\frac{(x - 0)^2}{b^2} + \frac{(y - 4)^2}{a^2} = 1 \Rightarrow \frac{x^2}{12} + \frac{(y - 4)^2}{16} = 1$ .
40. Since the foci are  $(0, -1)$  and  $(8, -1)$ , the ellipse has center  $(4, -1)$  with a horizontal axis and  $c = 4$ . The vertex  $(9, -1)$  is 5 units from the center, so  $a = 5$  and  $b = \sqrt{a^2 - c^2} = \sqrt{5^2 - 4^2} = \sqrt{9}$ . An equation is  $\frac{(x - 4)^2}{a^2} + \frac{(y + 1)^2}{b^2} = 1 \Rightarrow \frac{(x - 4)^2}{25} + \frac{(y + 1)^2}{9} = 1$ .
41. Center  $(2, 2)$ ,  $c = 2$ ,  $a = 3 \Rightarrow b = \sqrt{5} \Rightarrow \frac{1}{9}(x - 2)^2 + \frac{1}{5}(y - 2)^2 = 1$
42. Center  $(0, 0)$ ,  $c = 2$ , major axis horizontal  $\Rightarrow \frac{x^2}{a^2} + \frac{y^2}{b^2} = 1$  and  $b^2 = a^2 - c^2 = a^2 - 4$ . Since the ellipse passes through  $(2, 1)$ , we have  $2a = |PF_1| + |PF_2| = \sqrt{17} + 1 \Rightarrow a^2 = \frac{9 + \sqrt{17}}{2}$  and  $b^2 = \frac{1 + \sqrt{17}}{2}$ , so the ellipse has equation  $\frac{2x^2}{9 + \sqrt{17}} + \frac{2y^2}{1 + \sqrt{17}} = 1$ .
43. Center  $(0, 0)$ , vertical axis,  $c = 3$ ,  $a = 1 \Rightarrow b = \sqrt{8} = 2\sqrt{2} \Rightarrow y^2 - \frac{1}{8}x^2 = 1$
44. Center  $(0, 0)$ , horizontal axis,  $c = 6$ ,  $a = 4 \Rightarrow b = 2\sqrt{5} \Rightarrow \frac{1}{16}x^2 - \frac{1}{20}y^2 = 1$
45. Center  $(4, 3)$ , horizontal axis,  $c = 3$ ,  $a = 2 \Rightarrow b = \sqrt{5} \Rightarrow \frac{1}{4}(x - 4)^2 - \frac{1}{5}(y - 3)^2 = 1$
46. Center  $(2, 3)$ , vertical axis,  $c = 5$ ,  $a = 3 \Rightarrow b = 4 \Rightarrow \frac{1}{9}(y - 3)^2 - \frac{1}{16}(x - 2)^2 = 1$
47. Center  $(0, 0)$ , horizontal axis,  $a = 3$ ,  $\frac{b}{a} = 2 \Rightarrow b = 6 \Rightarrow \frac{1}{9}x^2 - \frac{1}{36}y^2 = 1$
48. Center  $(4, 2)$ , horizontal axis, asymptotes  $y - 2 = \pm(x - 4) \Rightarrow c = 2$ ,  $b/a = 1 \Rightarrow a = b \Rightarrow c^2 = 4 = a^2 + b^2 = 2a^2 \Rightarrow a^2 = 2 \Rightarrow \frac{1}{2}(x - 4)^2 - \frac{1}{2}(y - 2)^2 = 1$



49. In Figure 8, we see that the point on the ellipse closest to a focus is the closer vertex (which is a distance  $a - c$  from it) while the farthest point is the other vertex (at a distance of  $a + c$ ). So for this lunar orbit,

$$(a - c) + (a + c) = 2a = (1728 + 110) + (1728 + 314), \text{ or } a = 1940; \text{ and}$$

$$(a + c) - (a - c) = 2c = 314 - 110, \text{ or } c = 102. \text{ Thus, } b^2 = a^2 - c^2 = 3,753,196, \text{ and the equation is}$$

$$\frac{x^2}{3,763,600} + \frac{y^2}{3,753,196} = 1.$$

50. (a) Choose  $V$  to be the origin, with  $x$ -axis through  $V$  and  $F$ . Then  $F$  is  $(p, 0)$ ,  $A$  is  $(p, 5)$ , so substituting  $A$  into the equation  $y^2 = 4px$  gives  $25 = 4p^2$  so  $p = \frac{5}{2}$  and  $y^2 = 10x$ .

$$(b) x = 11 \Rightarrow y = \sqrt{110} \Rightarrow |CD| = 2\sqrt{110}$$

51. (a) Set up the coordinate system so that  $A$  is  $(-200, 0)$  and  $B$  is  $(200, 0)$ .

$$|PA| - |PB| = (1200)(980) = 1,176,000 \text{ ft} = \frac{2450}{11} \text{ mi} = 2a \Rightarrow a = \frac{1225}{11}, \text{ and } c = 200 \text{ so}$$

$$b^2 = c^2 - a^2 = \frac{3,339,375}{121} \Rightarrow \frac{121x^2}{1,500,625} - \frac{121y^2}{3,339,375} = 1.$$

$$(b) \text{ Due north of } B \Rightarrow x = 200 \Rightarrow \frac{(121)(200)^2}{1,500,625} - \frac{121y^2}{3,339,375} = 1 \Rightarrow y = \frac{133,575}{539} \approx 248 \text{ mi}$$

52.  $|PF_1| - |PF_2| = \pm 2a \Leftrightarrow \sqrt{(x+c)^2 + y^2} - \sqrt{(x-c)^2 + y^2} = \pm 2a \Leftrightarrow$

$$\sqrt{(x+c)^2 + y^2} = \sqrt{(x-c)^2 + y^2} \pm 2a \Leftrightarrow (x+c)^2 + y^2 = (x-c)^2 + y^2 + 4a^2 \pm 4a\sqrt{(x-c)^2 + y^2}$$

$$\Leftrightarrow 4cx - 4a^2 = \pm 4a\sqrt{(x-c)^2 + y^2} \Leftrightarrow c^2x^2 - 2a^2cx + a^4 = a^2(x^2 - 2cx + c^2 + y^2) \Leftrightarrow$$

$$(c^2 - a^2)x^2 - a^2y^2 = a^2(c^2 - a^2) \Leftrightarrow b^2x^2 - a^2y^2 = a^2b^2 \text{ (where } b^2 = c^2 - a^2) \Leftrightarrow \frac{x^2}{a^2} - \frac{y^2}{b^2} = 1$$

53. The function whose graph is the upper branch of this hyperbola is concave upward. The

$$\text{function is } y = f(x) = a\sqrt{1 + \frac{x^2}{b^2}} = \frac{a}{b}\sqrt{b^2 + x^2}, \text{ so } y' = \frac{a}{b}x(b^2 + x^2)^{-1/2} \text{ and}$$

$$y'' = \frac{a}{b}[(b^2 + x^2)^{-1/2} - x^2(b^2 + x^2)^{-3/2}] = ab(b^2 + x^2)^{-3/2} > 0 \text{ for all } x, \text{ and so } f \text{ is concave upward.}$$

54. We can follow exactly the same sequence of steps as in the derivation of Formula 4, except we use the points  $(1, 1)$  and  $(-1, -1)$  in the distance formula (first equation of that derivation) so

$$\sqrt{(x-1)^2 + (y-1)^2} + \sqrt{(x+1)^2 + (y+1)^2} = 4 \text{ will lead (after moving the second term to the right,}$$

$$\text{squaring, and simplifying) to } 2\sqrt{(x+1)^2 + (y+1)^2} = x + y + 4, \text{ which, after squaring and simplifying again,}$$

$$\text{leads to } 3x^2 - 2xy + 3y^2 = 8.$$

55. (a) If  $k > 16$ , then  $k - 16 > 0$ , and  $\frac{x^2}{k} + \frac{y^2}{k-16} = 1$  is an *ellipse* since it is the sum of two squares on the left side.

(b) If  $0 < k < 16$ , then  $k - 16 < 0$ , and  $\frac{x^2}{k} + \frac{y^2}{k-16} = 1$  is a *hyperbola* since it is the difference of two squares on the left side.

(c) If  $k < 0$ , then  $k - 16 < 0$ , and there is *no curve* since the left side is the sum of two negative terms, which cannot equal 1.

(d) In case (a),  $a^2 = k$ ,  $b^2 = k - 16$ , and  $c^2 = a^2 - b^2 = 16$ , so the foci are at  $(\pm 4, 0)$ . In case (b),  $k - 16 < 0$ , so  $a^2 = k$ ,  $b^2 = 16 - k$ , and  $c^2 = a^2 + b^2 = 16$ , and so again the foci are at  $(\pm 4, 0)$ .

56. (a)  $y^2 = 4px \Rightarrow 2yy' = 4p \Rightarrow y' = \frac{2p}{y}$ , so the tangent line is

$$y - y_0 = \frac{2p}{y_0}(x - x_0) \Rightarrow yy_0 - y_0^2 = 2p(x - x_0) \Leftrightarrow$$

$$yy_0 - 4px_0 = 2px - 2px_0 \Rightarrow yy_0 = 2p(x + x_0).$$

- (b) The  $x$ -intercept is  $-x_0$ .

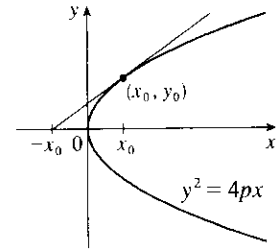

57. Use the parametrization  $x = 2 \cos t$ ,  $y = \sin t$ ,  $0 \leq t \leq 2\pi$  to get

$$L = 4 \int_0^{\pi/2} \sqrt{(dx/dt)^2 + (dy/dt)^2} dt = 4 \int_0^{\pi/2} \sqrt{4 \sin^2 t + \cos^2 t} dt = 4 \int_0^{\pi/2} \sqrt{3 \sin^2 t + 1} dt$$

Using Simpson's Rule with  $n = 10$ ,  $\Delta t = \frac{\pi/2 - 0}{10} = \frac{\pi}{20}$ , and  $f(t) = \sqrt{3 \sin^2 t + 1}$ , we get

$$L \approx \frac{4}{3} \left( \frac{\pi}{20} \right) \left[ f(0) + 4f\left(\frac{\pi}{20}\right) + 2f\left(\frac{2\pi}{20}\right) + \cdots + 2f\left(\frac{8\pi}{20}\right) + 4f\left(\frac{9\pi}{20}\right) + f\left(\frac{\pi}{2}\right) \right] \approx 9.69$$

58. The length of the major axis is  $2a$ , so  $a = \frac{1}{2}(1.18 \times 10^{10}) = 5.9 \times 10^9$ . The length of the minor axis is  $2b$ , so  $b = \frac{1}{2}(1.14 \times 10^{10}) = 5.7 \times 10^9$ . An equation of the ellipse is  $\frac{x^2}{a^2} + \frac{y^2}{b^2} = 1$ , or converting into parametric equations,  $x = a \cos \theta$  and  $y = b \sin \theta$ . So

$$L = 4 \int_0^{\pi/2} \sqrt{(dx/d\theta)^2 + (dy/d\theta)^2} d\theta = 4 \int_0^{\pi/2} \sqrt{a^2 \sin^2 \theta + b^2 \cos^2 \theta} d\theta$$

Using Simpson's Rule with  $n = 10$ ,  $\Delta \theta = \frac{\pi/2 - 0}{10} = \frac{\pi}{20}$ , and  $f(\theta) = \sqrt{a^2 \sin^2 \theta + b^2 \cos^2 \theta}$ , we get

$$\begin{aligned} L &\approx 4 \cdot S_{10} \\ &= 4 \cdot \frac{\pi}{20 \cdot 3} \left[ f(0) + 4f\left(\frac{\pi}{20}\right) + 2f\left(\frac{2\pi}{20}\right) + \cdots + 2f\left(\frac{8\pi}{20}\right) + 4f\left(\frac{9\pi}{20}\right) + f\left(\frac{\pi}{2}\right) \right] \\ &\approx 3.64 \times 10^{10} \text{ km} \end{aligned}$$

59.  $\frac{x^2}{a^2} + \frac{y^2}{b^2} = 1 \Rightarrow \frac{2x}{a^2} + \frac{2yy'}{b^2} = 0 \Rightarrow y' = -\frac{b^2 x}{a^2 y}$  ( $y \neq 0$ ). Thus, the slope of the tangent line at  $P$  is  $-\frac{b^2 x_1}{a^2 y_1}$ . The slope of  $F_1 P$  is  $\frac{y_1}{x_1 + c}$  and of  $F_2 P$  is  $\frac{y_1}{x_1 - c}$ . By the formula from Problems Plus, we have

$$\begin{aligned} \tan \alpha &= \frac{\frac{y_1}{x_1 + c} + \frac{b^2 x_1}{a^2 y_1}}{1 - \frac{b^2 x_1 y_1}{a^2 y_1 (x_1 + c)}} = \frac{a^2 y_1^2 + b^2 x_1 (x_1 + c)}{a^2 y_1 (x_1 + c) - b^2 x_1 y_1} = \frac{a^2 b^2 + b^2 c x_1}{c^2 x_1 y_1 + a^2 c y_1} \left[ \begin{array}{l} \text{using } b^2 x_1^2 + a^2 y_1^2 = a^2 b^2 \\ \text{and } a^2 - b^2 = c^2 \end{array} \right] \\ &= \frac{b^2 (c x_1 + a^2)}{c y_1 (c x_1 + a^2)} = \frac{b^2}{c y_1} \end{aligned}$$

and

$$\tan \beta = \frac{-\frac{y_1}{x_1 - c} - \frac{b^2 x_1}{a^2 y_1}}{1 - \frac{b^2 x_1 y_1}{a^2 y_1 (x_1 - c)}} = \frac{-a^2 y_1^2 - b^2 x_1 (x_1 - c)}{a^2 y_1 (x_1 - c) - b^2 x_1 y_1} = \frac{-a^2 b^2 + b^2 c x_1}{c^2 x_1 y_1 - a^2 c y_1} = \frac{b^2 (c x_1 - a^2)}{c y_1 (c x_1 - a^2)} = \frac{b^2}{c y_1}$$

So  $\alpha = \beta$ .

60. The slopes of the line segments  $F_1P$  and  $F_2P$  are  $\frac{y_1}{x_1 + c}$  and  $\frac{y_1}{x_1 - c}$ , where  $P$  is  $(x_1, y_1)$ . Differentiating implicitly,  $\frac{2x}{a^2} - \frac{2yy'}{b^2} = 0 \Rightarrow y' = \frac{b^2x}{a^2y} \Rightarrow$  the slope of the tangent at  $P$  is  $\frac{b^2x_1}{a^2y_1}$ , so by the formula from Problems Plus,

$$\begin{aligned}\tan \alpha &= \frac{\frac{b^2x_1}{a^2y_1} - \frac{y_1}{x_1 + c}}{1 + \frac{b^2x_1y_1}{a^2y_1(x_1 + c)}} = \frac{b^2x_1(x_1 + c) - a^2y_1^2}{a^2y_1(x_1 + c) + b^2x_1y_1} \\ &= \frac{b^2(cx_1 + a^2)}{cy_1(cx_1 + a^2)} \left[ \begin{array}{l} \text{using } x_1^2/a^2 - y_1^2/b^2 = 1 \\ \text{and } a^2 + b^2 = c^2 \end{array} \right] = \frac{b^2}{cy_1}\end{aligned}$$

and

$$\tan \beta = \frac{\frac{b^2x_1}{a^2y_1} + \frac{y_1}{x_1 - c}}{1 + \frac{b^2x_1y_1}{a^2y_1(x_1 - c)}} = \frac{-b^2x_1(x_1 - c) + a^2y_1^2}{a^2y_1(x_1 - c) + b^2x_1y_1} = \frac{b^2(cx_1 - a^2)}{cy_1(cx_1 - a^2)} = \frac{b^2}{cy_1}$$

So  $\alpha = \beta$ .

## 11.6 Conic Sections in Polar Coordinates

- The directrix  $y = 6$  is above the focus at the origin, so we use the form with “ $+e \sin \theta$ ” in the denominator. (See Theorem 6 and Figure 2.)  $r = \frac{ed}{1 + e \sin \theta} = \frac{\frac{7}{4} \cdot 6}{1 + \frac{7}{4} \sin \theta} = \frac{42}{4 + 7 \sin \theta}$
- The directrix  $x = 4$  is to the right of the focus at the origin, so we use the form with “ $+e \cos \theta$ ” in the denominator.  $e = 1$  for a parabola, so an equation is  $r = \frac{ed}{1 + e \cos \theta} = \frac{1 \cdot 4}{1 + 1 \cos \theta} = \frac{4}{1 + \cos \theta}$
- The directrix  $x = -5$  is to the left of the focus at the origin, so we use the form with “ $-e \cos \theta$ ” in the denominator.  $r = \frac{ed}{1 - e \cos \theta} = \frac{\frac{3}{4} \cdot 5}{1 - \frac{3}{4} \cos \theta} = \frac{15}{4 - 3 \cos \theta}$
- The directrix  $y = -2$  is below the focus at the origin, so we use the form with “ $-e \sin \theta$ ” in the denominator.  $r = \frac{ed}{1 - e \sin \theta} = \frac{2 \cdot 2}{1 - 2 \sin \theta} = \frac{4}{1 - 2 \sin \theta}$
- The vertex  $(4, 3\pi/2)$  is 4 units below the focus at the origin, so the directrix is 8 units below the focus ( $d = 8$ ), and we use the form with “ $-e \sin \theta$ ” in the denominator.  $e = 1$  for a parabola, so an equation is  $r = \frac{cd}{1 - e \sin \theta} = \frac{1(8)}{1 - 1 \sin \theta} = \frac{8}{1 - \sin \theta}$ .
- The vertex  $P(1, \pi/2)$  is 1 unit above the focus  $F$  at the origin, so  $|PF| = 1$  and we use the form with “ $+e \sin \theta$ ” in the denominator. The distance from the focus to the directrix  $l$  is  $d$ , so

$$e = \frac{|PF|}{|Pl|} \Rightarrow 0.8 = \frac{1}{d-1} \Rightarrow 0.8d - 0.8 = 1 \Rightarrow 0.8d = 1.8 \Rightarrow d = 2.25.$$

$$\text{An equation is } r = \frac{ed}{1 + e \sin \theta} = \frac{0.8(2.25)}{1 + 0.8 \sin \theta} = \frac{5}{5 + 4 \sin \theta}.$$

7. The directrix  $r = 4 \sec \theta$  (equivalent to  $r \cos \theta = 4$  or  $x = 4$ ) is to the right of the focus at the origin, so we will use the form with “ $+e \cos \theta$ ” in the denominator. The distance from the focus to the directrix is  $d = 4$ , so an equation is

$$r = \frac{ed}{1 + e \cos \theta} = \frac{0.5(4)}{1 + 0.5 \cos \theta} = \frac{2}{2 + \cos \theta}.$$

8. The directrix  $r = -6 \csc \theta$  (equivalent to  $r \sin \theta = -6$  or  $y = -6$ ) is below the focus at the origin, so we will use the form with “ $-e \sin \theta$ ” in the denominator. The distance from the focus to the directrix is  $d = 6$ , so an equation is

$$r = \frac{ed}{1 - e \sin \theta} = \frac{3(6)}{1 - 3 \sin \theta} = \frac{18}{1 - 3 \sin \theta}.$$

9.  $r = \frac{1}{1 + \sin \theta} = \frac{ed}{1 + e \sin \theta}$ , where  $d = e = 1$ .

(a) Eccentricity =  $e = 1$

(b) Since  $e = 1$ , the conic is a parabola.

(c) Since “ $+e \sin \theta$ ” appears in the denominator, the directrix is above the focus at the origin.  $d = |Fl| = 1$ , so an equation of the directrix is  $y = 1$ .

(d) The vertex is at  $(\frac{1}{2}, \frac{\pi}{2})$ , midway between the focus and the directrix.

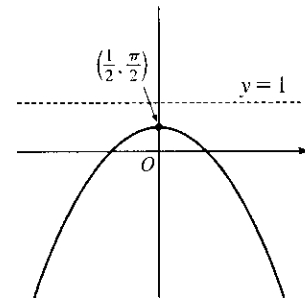

10.  $r = \frac{6}{3 + 2 \sin \theta} = \frac{2}{1 + \frac{2}{3} \sin \theta} = \frac{\frac{2}{3} \cdot 3}{1 + \frac{2}{3} \sin \theta}$

(a)  $e = \frac{2}{3}$

(b) Ellipse

(c)  $y = 3$

(d) Vertices  $(\frac{6}{5}, \frac{\pi}{2})$  and  $(6, \frac{3\pi}{2})$ ; center  $(\frac{12}{5}, \frac{3\pi}{2})$

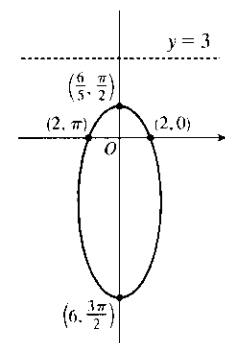

11.  $r = \frac{12}{4 - \sin \theta} = \frac{1/4}{1 - \frac{1}{4} \sin \theta} = \frac{3}{1 - \frac{1}{4} \sin \theta}$ , where  $e = \frac{1}{4}$  and  $ed = 3 \Rightarrow d = 12$ .

(a) Eccentricity =  $e = \frac{1}{4}$

(b) Since  $e = \frac{1}{4} < 1$ , the conic is an ellipse.

(c) Since “ $-e \sin \theta$ ” appears in the denominator, the directrix is below the focus at the origin.  $d = |Fl| = 12$ , so an equation of the directrix is  $y = -12$ .

(d) The vertices are  $(4, \frac{\pi}{2})$  and  $(\frac{12}{5}, \frac{3\pi}{2})$ , so the center is midway between them, that is,  $(\frac{4}{5}, \frac{\pi}{2})$ .

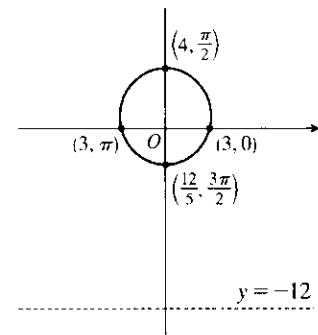

$$12. r = \frac{4}{2 - 3 \cos \theta} = \frac{2}{1 - \frac{3}{2} \cos \theta} = \frac{\frac{3}{2} \cdot \frac{4}{3}}{1 - \frac{3}{2} \cos \theta}$$

- (a)  $e = \frac{3}{2}$
- (b) Hyperbola
- (c)  $x = -\frac{4}{3}$
- (d) The vertices are  $(-4, 0)$  and  $(\frac{4}{5}, \pi) = (-\frac{4}{5}, 0)$ , so the center is  $(-\frac{12}{5}, 0)$ . The asymptotes are parallel to  $\theta = \pm \cos^{-1} \frac{2}{3}$ . [Their slopes are  $\pm \tan(\cos^{-1} \frac{2}{3}) = \pm \frac{\sqrt{5}}{2}$ .]

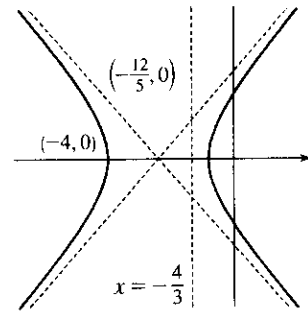

$$13. r = \frac{9}{6 + 2 \cos \theta} \cdot \frac{1/6}{1/6} = \frac{3/2}{1 + \frac{1}{3} \cos \theta}, \text{ where } e = \frac{1}{3} \text{ and } ed = \frac{3}{2} \Rightarrow d = \frac{9}{2}.$$

- (a) Eccentricity =  $e = \frac{1}{3}$
- (b) Since  $e = \frac{1}{3} < 1$ , the conic is an ellipse.
- (c) Since “ $+e \cos \theta$ ” appears in the denominator, the directrix is to the right of the focus at the origin.  $d = |Fl| = \frac{9}{2}$ , so an equation of the directrix is  $x = \frac{9}{2}$ .
- (d) The vertices are  $(\frac{9}{8}, 0)$  and  $(\frac{9}{4}, \pi)$ , so the center is midway between them, that is,  $(\frac{9}{16}, \pi)$ .

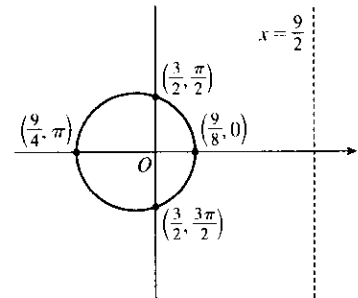

$$14. r = \frac{5}{2 - 2 \sin \theta} = \frac{\frac{5}{2}}{1 - \sin \theta}$$

- (a)  $e = 1$
- (b) Parabola
- (c)  $y = -\frac{5}{2}$
- (d) The focus is  $(0, 0)$ , so the vertex is  $(\frac{5}{4}, \frac{3\pi}{2})$  and the parabola opens up.

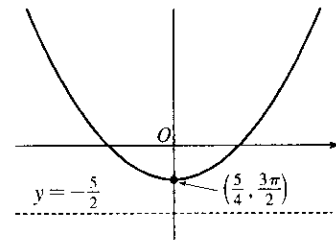

$$15. r = \frac{3}{4 - 8 \cos \theta} \cdot \frac{1/4}{1/4} = \frac{3/4}{1 - 2 \cos \theta}, \text{ where } e = 2 \text{ and } ed = \frac{3}{4} \Rightarrow d = \frac{3}{8}.$$

- (a) Eccentricity =  $e = 2$
- (b) Since  $e = 2 > 1$ , the conic is a hyperbola.
- (c) Since “ $-e \cos \theta$ ” appears in the denominator, the directrix is to the left of the focus at the origin.  $d = |Fl| = \frac{3}{8}$ , so an equation of the directrix is  $x = -\frac{3}{8}$ .
- (d) The vertices are  $(-\frac{3}{4}, 0)$  and  $(\frac{1}{4}, \pi)$ , so the center is midway between them, that is,  $(\frac{1}{2}, \pi)$ .

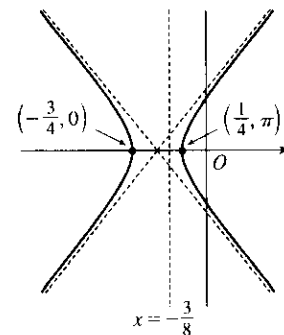

16.  $r = \frac{4}{2 + \cos \theta} = \frac{2}{1 + \frac{1}{2} \cos \theta} = \frac{\frac{1}{2} \cdot 4}{1 + \frac{1}{2} \cos \theta}$

(a)  $e = \frac{1}{2}$

(b) Ellipse

(c)  $x = 4$

(d) The vertices are  $(\frac{4}{3}, 0)$  and  $(4, \pi) = (-4, 0)$ , so the center is  $(-\frac{4}{3}, 0)$ .

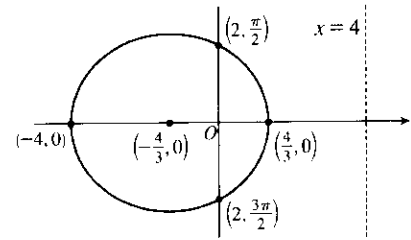

17. (a) The equation is  $r = \frac{1}{4 - 3 \cos \theta} = \frac{1/4}{1 - \frac{3}{4} \cos \theta}$ , so  $e = \frac{3}{4}$  and

$ed = \frac{1}{4} \Rightarrow d = \frac{1}{3}$ . The conic is an ellipse, and the equation of its directrix is  $x = r \cos \theta = -\frac{1}{3} \Rightarrow r = -\frac{1}{3 \cos \theta}$ . We must be careful in our choice of parameter values in this equation ( $-1 \leq \theta \leq 1$  works well).

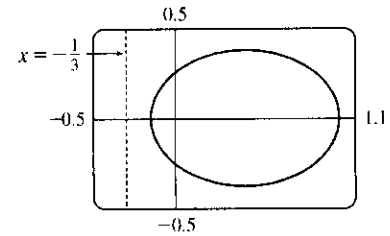

(b) The equation is obtained by replacing  $\theta$  with  $\theta - \frac{\pi}{3}$  in the equation of the original conic (see Example 4), so  $r = \frac{1}{4 - 3 \cos(\theta - \frac{\pi}{3})}$ .

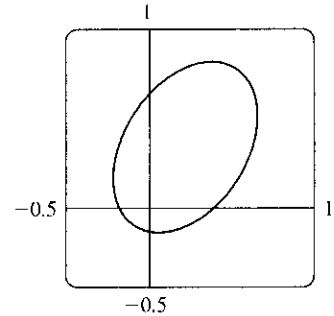

18.  $r = \frac{5}{2 + 2 \sin \theta} = \frac{5/2}{1 + \sin \theta}$ , so  $e = 1$  and  $d = \frac{5}{2}$ . The equation of the

directrix is  $y = r \sin \theta = \frac{5}{2} \Rightarrow r = \frac{5}{2 \sin \theta}$ . If the parabola is rotated about its focus (the origin) through  $\frac{\pi}{6}$ , its equation is the same as that of the original, with  $\theta$  replaced by  $\theta - \frac{\pi}{6}$  (see Example 4), so

$r = \frac{5}{2 + 2 \sin(\theta - \pi/6)}$ . In graphing each of these curves, we must be careful to select parameter ranges which prevent the denominator from vanishing while still showing enough of the curve.

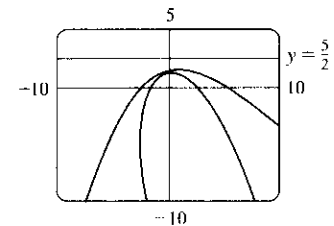

19. For  $e < 1$  the curve is an ellipse. It is nearly circular when  $e$  is close to 0. As  $e$  increases, the graph is stretched out to the right, and grows larger (that is, its right-hand focus moves to the right while its left-hand focus remains at the origin.) At  $e = 1$ , the curve becomes a parabola with focus at the origin.

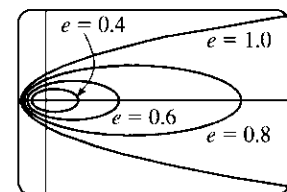

20. (a) The value of  $d$  does not seem to affect the shape of the conic (a parabola) at all, just its size, position, and orientation (for  $d < 0$  it opens upward, for  $d > 0$  it opens downward).

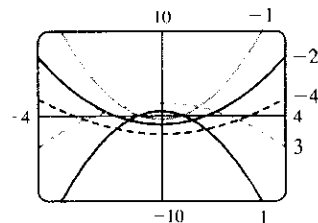

(b) We consider only positive values of  $e$ . When  $0 < e < 1$ , the conic is an ellipse. As  $e \rightarrow 0^+$ , the graph approaches perfect roundness and zero size. As  $e$  increases, the ellipse becomes more elongated, until at  $e = 1$  it turns into a parabola. For  $e > 1$ , the conic is a hyperbola, which moves downward and gets broader as  $e$  continues to increase.

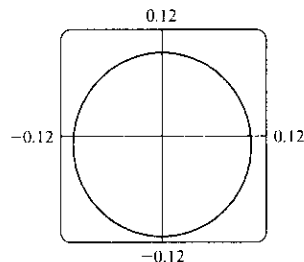

$e = 0.1$

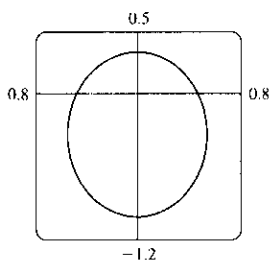

$e = 0.5$

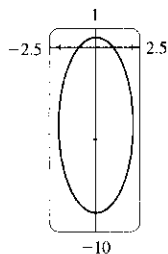

$e = 0.9$

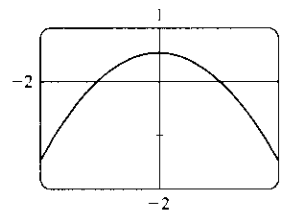

$e = 1$

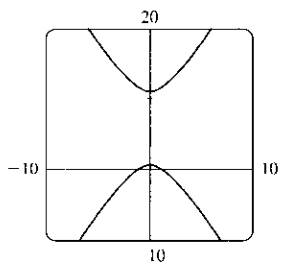

$e = 1.1$

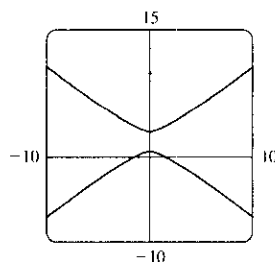

$e = 1.5$

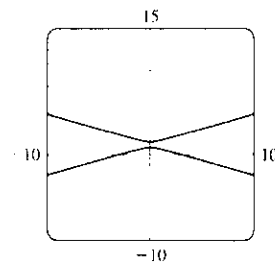

$e = 10$

$$21. |PF| = e|Pl| \Rightarrow r = e[d - r \cos(\pi - \theta)] = e(d + r \cos \theta) \Rightarrow r(1 - e \cos \theta) = ed \Rightarrow r = \frac{ed}{1 - e \cos \theta}$$

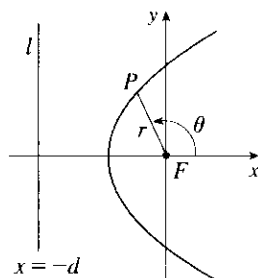

$$22. |PF| = e|Pl| \Rightarrow r = e[d - r \sin \theta] \Rightarrow r(1 + e \sin \theta) = ed \Rightarrow r = \frac{ed}{1 + e \sin \theta}$$

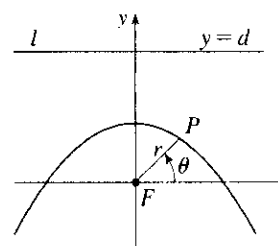

23.  $|PF| = e|Pl| \Rightarrow r = e[d - r \sin(\theta - \pi)] = e(d + r \sin \theta) \Rightarrow$   
 $r(1 - e \sin \theta) = ed \Rightarrow r = \frac{ed}{1 - e \sin \theta}$

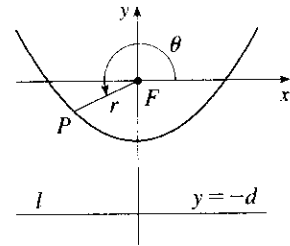

24. The parabolas intersect at the two points where  $\frac{c}{1 + \cos \theta} = \frac{d}{1 - \cos \theta} \Rightarrow \cos \theta = \frac{c-d}{c+d} \Rightarrow r = \frac{c+d}{2}$ .

For the first parabola,  $\frac{dr}{d\theta} = \frac{c \sin \theta}{(1 + \cos \theta)^2}$ , so

$$\frac{dy}{dx} = \frac{(dr/d\theta) \sin \theta + r \cos \theta}{(dr/d\theta) \cos \theta - r \sin \theta} = \frac{c \sin^2 \theta + c \cos \theta(1 + \cos \theta)}{c \sin \theta \cos \theta - c \sin \theta(1 + \cos \theta)} = \frac{1 + \cos \theta}{-\sin \theta}$$

and similarly for the second,  $\frac{dy}{dx} = \frac{1 - \cos \theta}{\sin \theta} = \frac{\sin \theta}{1 + \cos \theta}$ . Since the product of these slopes is  $-1$ , the parabolas intersect at right angles.

25. (a) If the directrix is  $x = -d$ , then  $r = \frac{ed}{1 - e \cos \theta}$  [see Figure 2(b)], and, from (4),  $a^2 = \frac{e^2 d^2}{(1 - e^2)^2} \Rightarrow$

$$ed = a(1 - e^2). \text{ Therefore, } r = \frac{a(1 - e^2)}{1 - e \cos \theta}.$$

(b)  $e = 0.017$  and the major axis  $= 2a = 2.99 \times 10^8 \Rightarrow a = 1.495 \times 10^8$ .

$$\text{Therefore } r = \frac{1.495 \times 10^8 [1 - (0.017)^2]}{1 - 0.017 \cos \theta} \approx \frac{1.49 \times 10^8}{1 - 0.017 \cos \theta}.$$

26. (a) The Sun is at point  $F$  in Figure 1 so that perihelion is in the positive  $x$ -direction and aphelion is in the negative  $x$ -direction. At perihelion,  $\theta = 0$ , so  $r = \frac{a(1 - e^2)}{1 + e \cos 0} = \frac{a(1 - e)(1 + e)}{1 + e} = a(1 - e)$ .

$$\text{At aphelion, } \theta = \pi, \text{ so } r = \frac{a(1 - e^2)}{1 + e \cos \pi} = \frac{a(1 - e)(1 + e)}{1 - e} = a(1 + e).$$

(b) At perihelion,  $r = a(1 - e) \approx (1.495 \times 10^8)(1 - 0.017) \approx 1.47 \times 10^8$  km.

At aphelion,  $r = a(1 + e) \approx (1.495 \times 10^8)(1 + 0.017) \approx 1.52 \times 10^8$  km.

27. Here  $2a =$  length of major axis  $= 36.18$  AU  $\Rightarrow a = 18.09$  AU and  $e = 0.97$ . By Exercise 25(a), the equation of the orbit is  $r = \frac{18.09[1 - (0.97)^2]}{1 - 0.97 \cos \theta} \approx \frac{1.07}{1 - 0.97 \cos \theta}$ . By Exercise 26(a), the maximum distance from the comet to the sun is  $18.09(1 + 0.97) \approx 35.64$  AU or about 3.314 billion miles.

28. Here  $2a =$  length of major axis  $= 356.5$  AU  $\Rightarrow a = 178.25$  AU and  $e = 0.9951$ . By Exercise 25(a), the equation of the orbit is  $r = \frac{178.25[1 - (0.9951)^2]}{1 - 0.9951 \cos \theta} \approx \frac{1.7426}{1 - 0.9951 \cos \theta}$ . By Exercise 26(a), the minimum distance from the comet to the sun is  $178.25(1 - 0.9951) \approx 0.8734$  AU or about 81 million miles.

29. The minimum distance is at perihelion, where

$$4.6 \times 10^7 = r = a(1 - e) = a(1 - 0.206) = a(0.794) \Rightarrow a = 4.6 \times 10^7 / 0.794. \text{ So the maximum distance, which is at aphelion, is } r = a(1 + e) = (4.6 \times 10^7 / 0.794)(1.206) \approx 7.0 \times 10^7 \text{ km.}$$



30. At perihelion,  $r = a(1 - e) = 4.43 \times 10^9$ , and at aphelion,  $r = a(1 + e) = 7.37 \times 10^9$ . Adding, we get  $2a = 11.80 \times 10^9$ , so  $a = 5.90 \times 10^9$  km. Therefore  $1 + e = a(1 + e)/a = \frac{7.37}{5.90} \approx 1.249$  and  $e \approx 0.249$ .
31. From Exercise 29, we have  $e = 0.206$  and  $a(1 - e) = 4.6 \times 10^7$  km. Thus,  $a = 4.6 \times 10^7/0.794$ . From Exercise 25, we can write the equation of Mercury's orbit as  $r = a \frac{1 - e^2}{1 - e \cos \theta}$ . So since

$$\frac{dr}{d\theta} = \frac{-a(1 - e^2)e \sin \theta}{(1 - e \cos \theta)^2} \Rightarrow$$

$$r^2 + \left(\frac{dr}{d\theta}\right)^2 = \frac{a^2(1 - e^2)^2}{(1 - e \cos \theta)^2} + \frac{a^2(1 - e^2)^2 e^2 \sin^2 \theta}{(1 - e \cos \theta)^4} = \frac{a^2(1 - e^2)^2}{(1 - e \cos \theta)^4} (1 - 2e \cos \theta + e^2)$$

the length of the orbit is

$$L = \int_0^{2\pi} \sqrt{r^2 + (dr/d\theta)^2} d\theta = a(1 - e^2) \int_0^{2\pi} \frac{\sqrt{1 + e^2 - 2e \cos \theta}}{(1 - e \cos \theta)^2} d\theta \approx 3.6 \times 10^8 \text{ km}$$

This seems reasonable, since Mercury's orbit is nearly circular, and the circumference of a circle of radius  $a$  is  $2\pi a \approx 3.6 \times 10^8$  km.

## 11 Review

### CONCEPT CHECK

- (a) A parametric curve is a set of points of the form  $(x, y) = (f(t), g(t))$ , where  $f$  and  $g$  are continuous functions of a variable  $t$ .

(b) Sketching a parametric curve, like sketching the graph of a function, is difficult to do in general. We can plot points on the curve by finding  $f(t)$  and  $g(t)$  for various values of  $t$ , either by hand or with a calculator or computer. Sometimes, when  $f$  and  $g$  are given by formulas, we can eliminate  $t$  from the equations  $x = f(t)$  and  $y = g(t)$  to get a Cartesian equation relating  $x$  and  $y$ . It may be easier to graph that equation than to work with the original formulas for  $x$  and  $y$  in terms of  $t$ .
- (a) You can find  $\frac{dy}{dx}$  as a function of  $t$  by calculating  $\frac{dy}{dx} = \frac{dy/dt}{dx/dt}$  (if  $dx/dt \neq 0$ ).

(b) Calculate the area as  $\int_a^b y dx = \int_\alpha^\beta g(t)f'(t)dt$  [or  $\int_\beta^\alpha g(t)f'(t)dt$  if the leftmost point is  $(f(\beta), g(\beta))$  rather than  $(f(\alpha), g(\alpha))$ ].
- (a)  $L = \int_\alpha^\beta \sqrt{(dx/dt)^2 + (dy/dt)^2} dt = \int_\alpha^\beta \sqrt{[f'(t)]^2 + [g'(t)]^2} dt$

(b)  $S = \int_\alpha^\beta 2\pi y \sqrt{(dx/dt)^2 + (dy/dt)^2} dt = \int_\alpha^\beta 2\pi g(t) \sqrt{[f'(t)]^2 + [g'(t)]^2} dt$
- (a) See Figure 5 in Section 11.3.

(b)  $x = r \cos \theta$ ,  $y = r \sin \theta$

(c) To find a polar representation  $(r, \theta)$  with  $r \geq 0$  and  $0 \leq \theta < 2\pi$ , first calculate  $r = \sqrt{x^2 + y^2}$ . Then  $\theta$  is specified by  $\cos \theta = x/r$  and  $\sin \theta = y/r$ .

5. (a) Calculate  $\frac{dy}{dx} = \frac{\frac{dy}{d\theta}}{\frac{dx}{d\theta}} = \frac{\frac{d}{d\theta}(y)}{\frac{d}{d\theta}(x)} = \frac{\frac{d}{d\theta}(r \sin \theta)}{\frac{d}{d\theta}(r \cos \theta)} = \frac{\left(\frac{dr}{d\theta}\right) \sin \theta + r \cos \theta}{\left(\frac{dr}{d\theta}\right) \cos \theta - r \sin \theta}$ , where  $r = f(\theta)$ .
- (b) Calculate  $A = \int_a^b \frac{1}{2} r^2 d\theta = \int_a^b \frac{1}{2} [f(\theta)]^2 d\theta$
- (c)  $L = \int_a^b \sqrt{(dx/d\theta)^2 + (dy/d\theta)^2} d\theta = \int_a^b \sqrt{r^2 + (dr/d\theta)^2} d\theta = \int_a^b \sqrt{[f(\theta)]^2 + [f'(\theta)]^2} d\theta$
6. (a) A parabola is a set of points in a plane whose distances from a fixed point  $F$  (the focus) and a fixed line  $l$  (the directrix) are equal.
- (b)  $x^2 = 4py$ ;  $y^2 = 4px$
7. (a) An ellipse is a set of points in a plane the sum of whose distances from two fixed points (the foci) is a constant.
- (b)  $\frac{x^2}{a^2} + \frac{y^2}{a^2 - c^2} = 1$ .
8. (a) A hyperbola is a set of points in a plane the difference of whose distances from two fixed points (the foci) is a constant. This difference should be interpreted as the larger distance minus the smaller distance.
- (b)  $\frac{x^2}{a^2} - \frac{y^2}{c^2 - a^2} = 1$
- (c)  $y = \pm \frac{\sqrt{c^2 - a^2}}{a} x$
9. (a) If a conic section has focus  $F$  and corresponding directrix  $l$ , then the eccentricity  $e$  is the fixed ratio  $|PF|/|Pl|$  for points  $P$  of the conic section.
- (b)  $e < 1$  for an ellipse;  $e > 1$  for a hyperbola;  $e = 1$  for a parabola.
- (c)  $x = d$ :  $r = \frac{ed}{1 + e \cos \theta}$ ;  $x = -d$ :  $r = \frac{ed}{1 - e \cos \theta}$ ;  $y = d$ :  $r = \frac{ed}{1 + e \sin \theta}$ ;  $y = -d$ :  $r = \frac{ed}{1 - e \sin \theta}$ .

---

TRUE-FALSE QUIZ

---

1. False. Consider the curve defined by  $x = f(t) = (t - 1)^3$  and  $y = g(t) = (t - 1)^2$ . Then  $g'(t) = 2(t - 1)$ , so  $g'(1) = 0$ , but its graph has a vertical tangent when  $t = 1$ . Note: The statement is true if  $f'(1) \neq 0$  when  $g'(1) = 0$ .
2. False. If  $x = f(t)$  and  $y = g(t)$  are twice differentiable, then  $\frac{d^2y}{dx^2} = \frac{d}{dx} \left( \frac{dy}{dx} \right) = \frac{\frac{d}{dt} \left( \frac{dy}{dx} \right)}{\frac{dx}{dt}}$ .
3. False. For example, if  $f(t) = \cos t$  and  $g(t) = \sin t$  for  $0 \leq t \leq 4\pi$ , then the curve is a circle of radius 1, hence its length is  $2\pi$ , but

$$\begin{aligned} \int_0^{4\pi} \sqrt{[f'(t)]^2 + [g'(t)]^2} dt &= \int_0^{4\pi} \sqrt{(-\sin t)^2 + (\cos t)^2} dt \\ &= \int_0^{4\pi} 1 dt = 4\pi, \end{aligned}$$

since as  $t$  increases from 0 to  $4\pi$ , the circle is traversed twice.

4. False. If  $(r, \theta) = (1, \pi)$ , then  $(x, y) = (-1, 0)$ , so  $\tan^{-1}(y/x) = \tan^{-1} 0 = 0 \neq \theta$ . The statement is true for points in quadrants I and IV.
5. True. The curve  $r = 1 - \sin 2\theta$  is unchanged if we rotate it through  $180^\circ$  about  $O$  because  $1 - \sin 2(\theta + \pi) = 1 - \sin(2\theta + 2\pi) = 1 - \sin 2\theta$ . So it's unchanged if we replace  $r$  by  $-r$ . (See the discussion after Example 8 in Section 11.3.) In other words, it's the same curve as  $r = -(1 - \sin 2\theta) = \sin 2\theta - 1$ .
6. True. The polar equation  $r = 2$ , the Cartesian equation  $x^2 + y^2 = 4$ , and the parametric equations  $x = 2 \sin 3t$ ,  $y = 2 \cos 3t$  ( $0 \leq t \leq 2\pi$ ) all describe the circle of radius 2 centered at the origin.
7. False. The first pair of equations yields the portion of the parabola  $y = x^2$  with  $x \geq 0$ , whereas the second pair of equations traces out the whole parabola  $y = x^2$ .
8. True.  $y^2 = 2y + 3x \Leftrightarrow (y - 1)^2 = 3x + 1 = 3(x + \frac{1}{3}) = 4(\frac{3}{4})(x + \frac{1}{3})$ , which is the equation of a parabola with vertex  $(-\frac{1}{3}, 1)$  and focus  $(-\frac{1}{3} + \frac{3}{4}, 1)$ , opening to the right.
9. True. By rotating and translating the parabola, we can assume it has an equation of the form  $y = cx^2$ , where  $c > 0$ . The tangent at the point  $(a, ca^2)$  is the line  $y - ca^2 = 2ca(x - a)$ ; i.e.,  $y = 2cax - ca^2$ . This tangent meets the parabola at the points  $(x, cx^2)$  where  $cx^2 = 2cax - ca^2$ . This equation is equivalent to  $x^2 = 2ax - a^2$  (since  $c > 0$ ). But  $x^2 = 2ax - a^2 \Leftrightarrow x^2 - 2ax + a^2 = 0 \Leftrightarrow (x - a)^2 = 0 \Leftrightarrow x = a \Leftrightarrow (x, cx^2) = (a, ca^2)$ . This shows that each tangent meets the parabola at exactly one point.
10. True. Consider a hyperbola with focus at the origin, oriented so that its polar equation is  $r = \frac{ed}{1 + e \cos \theta}$ , where  $e > 1$ . The directrix is  $x = d$ , but along the hyperbola we have 
$$x = r \cos \theta = \frac{ed \cos \theta}{1 + e \cos \theta} = d \left( \frac{e \cos \theta}{1 + e \cos \theta} \right) \neq d.$$

EXERCISES

1.  $x = t^2 + 4t, y = 2 - t, -4 \leq t \leq 1. t = 2 - y$ , so 
$$x = (2 - y)^2 + 4(2 - y) = 4 - 4y + y^2 + 8 - 4y = y^2 - 8y + 12 \Leftrightarrow x + 4 = y^2 - 8y + 16 = (y - 4)^2.$$
 This is part of a parabola with vertex  $(-4, 4)$ , opening to the right.

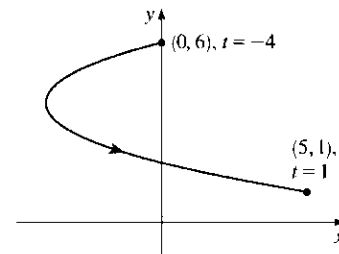

2.  $x = 1 + e^{2t}, y = e^t.$   
 $x = 1 + e^{2t} = 1 + (e^t)^2 = 1 + y^2, y > 0.$

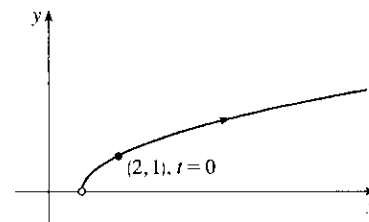

3.  $x = \tan \theta$ ,  $y = \cot \theta$ ,  $y = 1/\tan \theta = 1/x$ . The whole curve is traced out as  $\theta$  ranges over the open interval  $(-\frac{\pi}{2}, \frac{\pi}{2})$  [or any open interval of the form  $(-\frac{\pi}{2} + n\pi, \frac{\pi}{2} + n\pi)$ , where  $n$  is an integer].

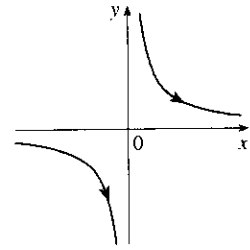

4.  $x = 2 \cos \theta$ ,  $y = 1 + \sin \theta$ ,  $\cos^2 \theta + \sin^2 \theta = 1 \Rightarrow (\frac{x}{2})^2 + (y - 1)^2 = 1 \Rightarrow \frac{x^2}{4} + (y - 1)^2 = 1$ . This is an ellipse, centered at  $(0, 1)$ , with semimajor axis of length 2 and semiminor axis of length 1.

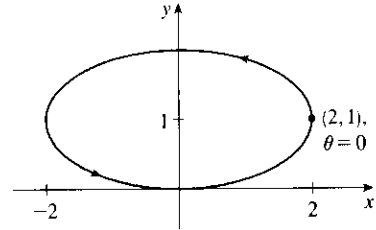

5. Three different sets of parametric equations for the curve  $y = \sqrt{x}$  are

(i)  $x = t$ ,  $y = \sqrt{t}$ ,  $t \geq 0$

(ii)  $x = t^4$ ,  $y = t^2$

(iii)  $x = \tan^2 t$ ,  $y = \tan t$ ,  $0 \leq t < \pi/2$

There are many other sets of equations that also give this curve.

6. For  $t < -1$ ,  $x > 0$  and  $y < 0$  with  $x$  decreasing and  $y$  increasing. When  $t = -1$ ,  $(x, y) = (0, 0)$ . When  $-1 < t < 0$ , we have  $-1 < x < 0$  and  $0 < y < 1/2$ . When  $t = 0$ ,  $(x, y) = (-1, 0)$ . When  $0 < t < 1$ ,  $-1 < x < 0$  and  $-\frac{1}{2} < y < 0$ . When  $t = 1$ ,  $(x, y) = (0, 0)$  again. When  $t > 1$ , both  $x$  and  $y$  are positive and increasing.

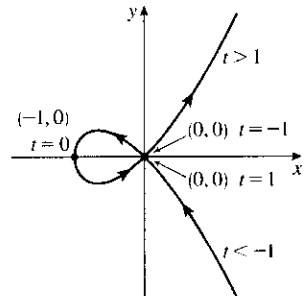

7.  $r = 1 - \cos \theta$ . This cardioid is symmetric about the polar axis.

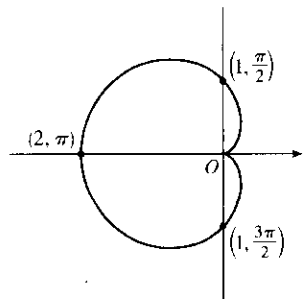
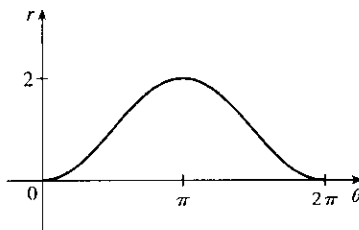

8.  $r = \sin 4\theta$ . This is an eight-leafed rose.

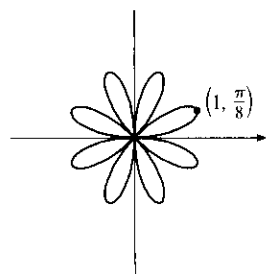
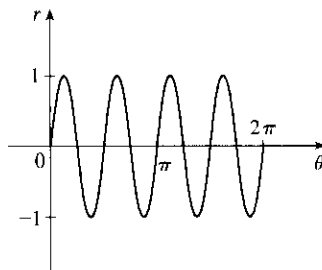

9.  $r = 1 + \cos 2\theta$ . The curve is symmetric about the pole and both the horizontal and vertical axes.

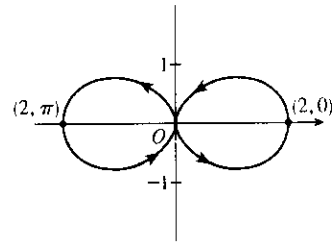
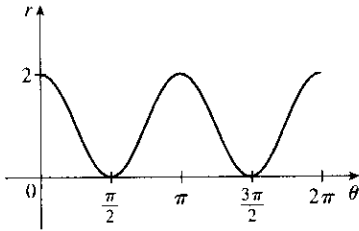

10.  $r = 3 + \cos 3\theta$ . The curve is symmetric about the horizontal axis.

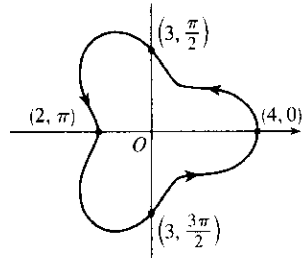
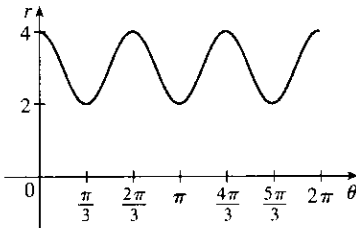

11.  $r^2 = \sec 2\theta \Rightarrow$   
 $r^2 \cos 2\theta = 1 \Rightarrow$   
 $r^2 (\cos^2 \theta - \sin^2 \theta) = 1 \Rightarrow$   
 $r^2 \cos^2 \theta - r^2 \sin^2 \theta = 1 \Rightarrow$   
 $x^2 - y^2 = 1$ , a hyperbola

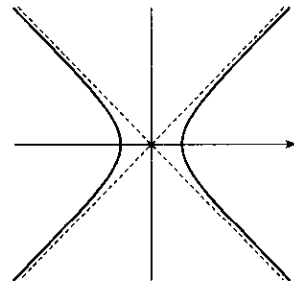
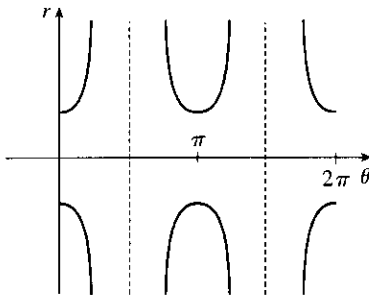

12.  $r = 2 \cos(\theta/2)$ . The curve is symmetric about the pole and both the horizontal and vertical axes.

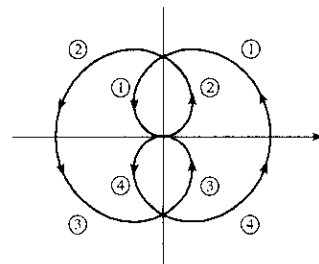
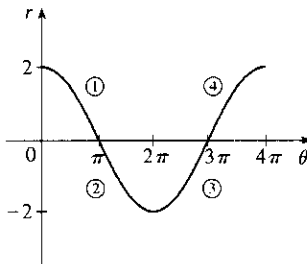

13.  $r = \frac{1}{1 + \cos \theta} \Rightarrow e = 1 \Rightarrow$  parabola;  $d = 1 \Rightarrow$  directrix  $x = 1$   
 and vertex  $(\frac{1}{2}, 0)$ ;  $y$ -intercepts are  $(1, \frac{\pi}{2})$  and  $(1, \frac{3\pi}{2})$ .

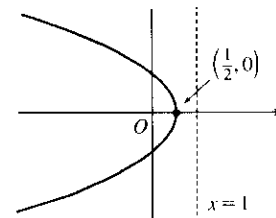

14.  $r = \frac{8}{4 + 3 \sin \theta} = \frac{\frac{3}{4} \cdot \frac{8}{3}}{1 + \frac{3}{4} \sin \theta}$ . This is an ellipse with focus at the pole, eccentricity  $\frac{3}{4}$ , and directrix  $y = \frac{8}{3}$ . The center is  $(\frac{24}{7}, \frac{3\pi}{2})$ .

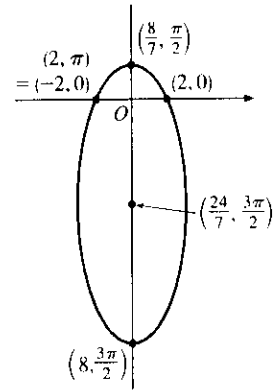

15.  $x + y = 2 \Leftrightarrow r \cos \theta + r \sin \theta = 2 \Leftrightarrow r(\cos \theta + \sin \theta) = 2 \Leftrightarrow r = \frac{2}{\cos \theta + \sin \theta}$

16.  $x^2 + y^2 = 2 \Rightarrow r^2 = 2 \Rightarrow r = \sqrt{2}$ . ( $r = -\sqrt{2}$  gives the same curve.)

17.  $r = (\sin \theta)/\theta$ . As  $\theta \rightarrow \pm\infty$ ,  $r \rightarrow 0$ . As  $\theta \rightarrow 0$ ,  $r \rightarrow 1$ . In the first figure, there are an infinite number of  $x$ -intercepts  $x = \pi n$ ,  $n$  a nonzero integer. These correspond to pole points in the second figure.

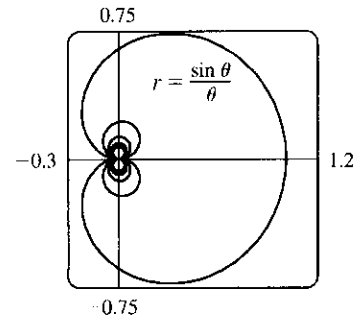
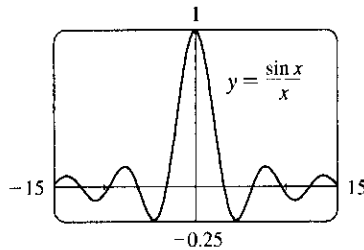

18.  $r = \frac{2}{4 - 3 \cos \theta} = \frac{1/2}{1 - \frac{3}{4} \cos \theta} \Rightarrow e = \frac{3}{4}$  and  $d = \frac{2}{3}$ . The equation of the directrix is  $x = -\frac{2}{3} \Rightarrow r = -2/(3 \cos \theta)$ . To obtain the equation of the rotated ellipse, we replace  $\theta$  in the original equation with  $\theta - \frac{2\pi}{3}$ , and get  $r = \frac{2}{4 - 3 \cos(\theta - \frac{2\pi}{3})}$ .

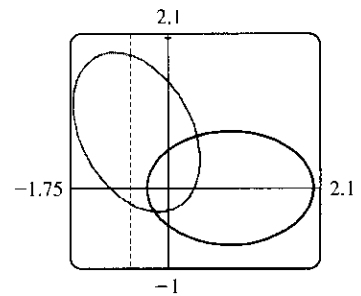

19.  $x = \ln t, y = 1 + t^2; t = 1$ .  $\frac{dy}{dt} = 2t$  and  $\frac{dx}{dt} = \frac{1}{t}$ , so  $\frac{dy}{dx} = \frac{dy/dt}{dx/dt} = \frac{2t}{1/t} = 2t^2$ . When  $t = 1$ ,  $(x, y) = (0, 2)$  and  $dy/dx = 2$ .

20.  $x = t^3 + 6t + 1, y = 2t - t^2; t = -1$ .  $\frac{dy}{dx} = \frac{dy/dt}{dx/dt} = \frac{2 - 2t}{3t^2 + 6}$ . When  $t = -1$ ,  $(x, y) = (-6, -3)$  and  $dy/dx = 4/9$ .

21.  $r = e^{-\theta} \Rightarrow y = r \sin \theta = e^{-\theta} \sin \theta$  and  $x = r \cos \theta = e^{-\theta} \cos \theta \Rightarrow$   
 $\frac{dy}{dx} = \frac{dy/d\theta}{dx/d\theta} = \frac{\frac{dr}{d\theta} \sin \theta + r \cos \theta}{\frac{dr}{d\theta} \cos \theta - r \sin \theta} = \frac{-e^{-\theta} \sin \theta + e^{-\theta} \cos \theta}{-e^{-\theta} \cos \theta - e^{-\theta} \sin \theta} \cdot \frac{-e^{\theta}}{-e^{\theta}} = \frac{\sin \theta - \cos \theta}{\cos \theta + \sin \theta}$ . When  $\theta = \pi$ ,  
 $\frac{dy}{dx} = \frac{0 - (-1)}{-1 + 0} = \frac{1}{-1} = -1$ .

$$22. r = 3 + \cos 3\theta \Rightarrow \frac{dy}{dx} = \frac{dy/d\theta}{dx/d\theta} = \frac{\frac{dr}{d\theta} \sin \theta + r \cos \theta}{\frac{dr}{d\theta} \cos \theta - r \sin \theta} = \frac{-3 \sin 3\theta \sin \theta + (3 + \cos 3\theta) \cos \theta}{-3 \sin 3\theta \cos \theta - (3 + \cos 3\theta) \sin \theta}. \text{ When}$$

$$\theta = \pi/2, \frac{dy}{dx} = \frac{(-3)(-1)(1) + (3+0) \cdot 0}{(-3)(-1)(0) - (3+0) \cdot 1} = \frac{3}{-3} = -1.$$

$$23. x = t \cos t, y = t \sin t. \quad \frac{dy}{dx} = \frac{dy/dt}{dx/dt} = \frac{t \cos t + \sin t}{-t \sin t + \cos t}, \quad \frac{d^2y}{dx^2} = \frac{\frac{d}{dt} \left( \frac{dy}{dx} \right)}{dx/dt}, \text{ where}$$

$$\frac{d}{dt} \left( \frac{dy}{dx} \right) = \frac{(-t \sin t + \cos t)(-t \sin t + 2 \cos t) - (t \cos t + \sin t)(-t \cos t - 2 \sin t)}{(-t \sin t + \cos t)^2}$$

$$= \frac{t^2 + 2}{(-t \sin t + \cos t)^2} \Rightarrow \frac{d^2y}{dx^2} = \frac{t^2 + 2}{(-t \sin t + \cos t)^3}.$$

$$24. x = 1 + t^2, y = t - t^3. \quad \frac{dy}{dt} = 1 - 3t^2 \text{ and } \frac{dx}{dt} = 2t, \text{ so } \frac{dy}{dx} = \frac{dy/dt}{dx/dt} = \frac{1 - 3t^2}{2t} = \frac{1}{2}t^{-1} - \frac{3}{2}t.$$

$$\frac{d^2y}{dx^2} = \frac{d(dy/dx)/dt}{dx/dt} = \frac{-\frac{1}{2}t^{-2} - \frac{3}{2}}{2t} = -\frac{1}{4}t^{-3} - \frac{3}{4}t^{-1} = -\frac{1}{4t^3}(1 + 3t^2) = -\frac{3t^2 + 1}{4t^3}.$$

25. We graph the curve  $x = t^3 - 3t, y = t^2 + t + 1$  for  $-2.2 \leq t \leq 1.2$ . By zooming in or using a cursor, we find that the lowest point is about  $(1.4, 0.75)$ . To find the exact values, we find the  $t$ -value at which  $dy/dt = 2t + 1 = 0 \Leftrightarrow t = -\frac{1}{2} \Leftrightarrow (x, y) = \left(\frac{11}{8}, \frac{3}{4}\right)$ .

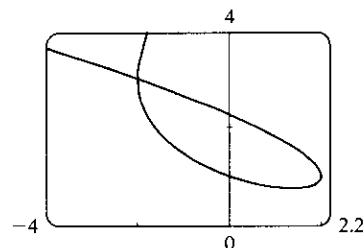

26. We estimate the coordinates of the point of intersection to be  $(-2, 3)$ . In fact this is exact, since both  $t = -2$  and  $t = 1$  give the point  $(-2, 3)$ . So the area enclosed by the loop is

$$\int_{t=-2}^{t=1} y \, dx = \int_{-2}^1 (t^2 + t + 1)(3t^2 - 3) \, dt = \int_{-2}^1 (3t^4 + 3t^3 - 3t - 3) \, dt$$

$$= \left[ \frac{3}{5}t^5 + \frac{3}{4}t^4 - \frac{3}{2}t^2 - 3t \right]_{-2}^1 = \left( \frac{3}{5} + \frac{3}{4} - \frac{3}{2} - 3 \right) - \left[ -\frac{96}{5} + 12 - 6 - (-6) \right] = \frac{81}{20}$$

$$27. x = 2a \cos t - a \cos 2t \Rightarrow \frac{dx}{dt} = -2a \sin t + 2a \sin 2t = 2a \sin t(2 \cos t - 1) = 0 \Leftrightarrow$$

$$\sin t = 0 \text{ or } \cos t = \frac{1}{2} \Rightarrow t = 0, \frac{\pi}{3}, \pi, \text{ or } \frac{5\pi}{3}.$$

$$y = 2a \sin t - a \sin 2t \Rightarrow$$

$$\frac{dy}{dt} = 2a \cos t - 2a \cos 2t = 2a(1 + \cos t - 2 \cos^2 t) = 2a(1 - \cos t)(1 + 2 \cos t) = 0 \Rightarrow t = 0, \frac{2\pi}{3}, \text{ or } \frac{4\pi}{3}.$$

Thus the graph has vertical tangents where

$$t = \frac{\pi}{3}, \pi \text{ and } \frac{5\pi}{3}, \text{ and horizontal tangents where}$$

$$t = \frac{2\pi}{3} \text{ and } \frac{4\pi}{3}. \text{ To determine what the slope is}$$

where  $t = 0$ , we use l'Hospital's Rule to evaluate

$$\lim_{t \rightarrow 0} \frac{dy/dt}{dx/dt} = 0, \text{ so there is a horizontal tangent}$$

there.

$t$	$x$	$y$
0	$a$	0
$\frac{\pi}{3}$	$\frac{3}{2}a$	$\frac{\sqrt{3}}{2}a$
$\frac{2\pi}{3}$	$-\frac{1}{2}a$	$\frac{3\sqrt{3}}{2}a$
$\pi$	$-3a$	0
$\frac{4\pi}{3}$	$-\frac{1}{2}a$	$-\frac{3\sqrt{3}}{2}a$
$\frac{5\pi}{3}$	$\frac{3}{2}a$	$-\frac{\sqrt{3}}{2}a$

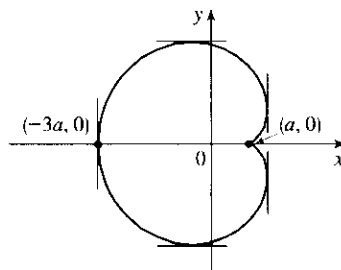

28. From Exercise 27,  $x = 2a \cos t - a \cos 2t$ ,  $y = 2a \sin t - a \sin 2t \Rightarrow$

$$\begin{aligned} A &= 2 \int_{\pi}^0 (2a \sin t - a \sin 2t)(-2a \sin t + 2a \sin 2t) dt = 4a^2 \int_0^{\pi} (2 \sin^2 t + \sin^2 2t - 3 \sin t \sin 2t) dt \\ &= 4a^2 \int_0^{\pi} [(1 - \cos 2t) + \frac{1}{2}(1 - \cos 4t) - 6 \sin^2 t \cos t] dt = 4a^2 [t - \frac{1}{2} \sin 2t + \frac{1}{2}t - \frac{1}{8} \sin 4t - 2 \sin^3 t]_0^{\pi} \\ &= 4a^2 (\frac{3}{2}) \pi = 6\pi a^2 \end{aligned}$$

29. The curve  $r^2 = 9 \cos 5\theta$  has 10 "petals." For instance, for  $-\frac{\pi}{10} \leq \theta \leq \frac{\pi}{10}$ , there are two petals, one with  $r > 0$  and one with  $r < 0$ .

$$A = 10 \int_{-\pi/10}^{\pi/10} \frac{1}{2} r^2 d\theta = 5 \int_{-\pi/10}^{\pi/10} 9 \cos 5\theta d\theta = 5 \cdot 9 \cdot 2 \int_0^{\pi/10} \cos 5\theta d\theta = 18 [\sin 5\theta]_0^{\pi/10} = 18$$

30.  $r = 1 - 3 \sin \theta$ . The inner loop is traced out as  $\theta$  goes from  $\alpha = \sin^{-1} \frac{1}{3}$  to  $\pi - \alpha$ , so

$$\begin{aligned} A &= \int_{\alpha}^{\pi-\alpha} \frac{1}{2} r^2 d\theta = \int_{\alpha}^{\pi/2} (1 - 3 \sin \theta)^2 d\theta = \int_{\alpha}^{\pi/2} [1 - 6 \sin \theta + \frac{9}{2}(1 - \cos 2\theta)] d\theta \\ &= [\frac{11}{2}\theta + 6 \cos \theta - \frac{9}{4} \sin 2\theta]_{\alpha}^{\pi/2} = \frac{11}{4}\pi - \frac{11}{2} \sin^{-1} \frac{1}{3} - 3\sqrt{2} \end{aligned}$$

31. The curves intersect when  $4 \cos \theta = 2 \Rightarrow \cos \theta = \frac{1}{2} \Rightarrow \theta = \pm \frac{\pi}{3}$   
for  $-\pi \leq \theta \leq \pi$ . The points of intersection are  $(2, \frac{\pi}{3})$  and  $(2, -\frac{\pi}{3})$ .

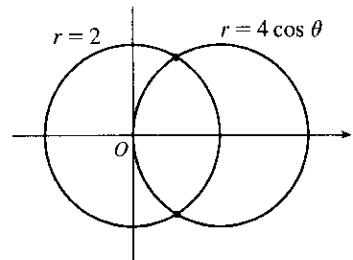

32. The two curves clearly both contain the pole. For other points of intersection,  $\cot \theta = 2 \cos(\theta + 2n\pi)$  or

$$\begin{aligned} -2 \cos(\theta + \pi + 2n\pi), \text{ both of which reduce to } \cot \theta &= 2 \cos \theta \Leftrightarrow \cos \theta = 2 \sin \theta \cos \theta \Leftrightarrow \\ \cos \theta(1 - 2 \sin \theta) = 0 \Rightarrow \cos \theta = 0 \text{ or } \sin \theta = \frac{1}{2} \Rightarrow \theta &= \frac{\pi}{6}, \frac{\pi}{2}, \frac{5\pi}{6} \text{ or } \frac{3\pi}{2} \Rightarrow \text{intersection points are} \\ (0, \frac{\pi}{2}), (\sqrt{3}, \frac{\pi}{6}), \text{ and } (\sqrt{3}, \frac{11\pi}{6}). \end{aligned}$$

33. The curves intersect where  $2 \sin \theta = \sin \theta + \cos \theta \Rightarrow$

$\sin \theta = \cos \theta \Rightarrow \theta = \frac{\pi}{4}$ , and also at the origin (at which  $\theta = \frac{3\pi}{4}$  on the second curve).

$$\begin{aligned} A &= \int_0^{\pi/4} \frac{1}{2} (2 \sin \theta)^2 d\theta + \int_{\pi/4}^{3\pi/4} \frac{1}{2} (\sin \theta + \cos \theta)^2 d\theta \\ &= \int_0^{\pi/4} (1 - \cos 2\theta) d\theta + \frac{1}{2} \int_{\pi/4}^{3\pi/4} (1 + \sin 2\theta) d\theta \\ &= [\theta - \frac{1}{2} \sin 2\theta]_0^{\pi/4} + [\frac{1}{2}\theta - \frac{1}{4} \cos 2\theta]_{\pi/4}^{3\pi/4} = \frac{1}{2}(\pi - 1) \end{aligned}$$

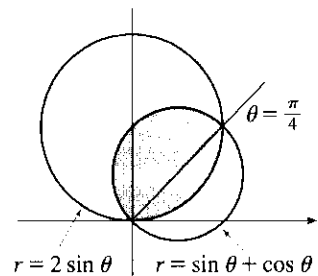

34.  $A = 2 \int_{-\pi/2}^{\pi/6} \frac{1}{2} [(2 + \cos 2\theta)^2 - (2 + \sin \theta)^2] d\theta$

$$\begin{aligned} &= \int_{-\pi/2}^{\pi/6} [4 \cos 2\theta + \cos^2 2\theta - 4 \sin \theta - \sin^2 \theta] d\theta \\ &= [2 \sin 2\theta + \frac{1}{2}\theta + \frac{1}{8} \sin 4\theta + 4 \cos \theta - \frac{1}{2}\theta + \frac{1}{4} \sin 2\theta]_{-\pi/2}^{\pi/6} \\ &= \frac{51}{16} \sqrt{3} \end{aligned}$$

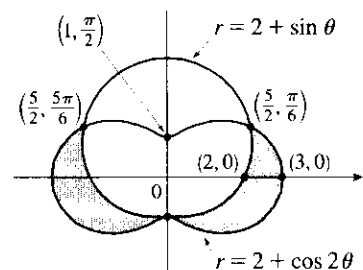



35.  $x = 3t^2, y = 2t^3.$

$$\begin{aligned} L &= \int_0^2 \sqrt{(dx/dt)^2 + (dy/dt)^2} dt = \int_0^2 \sqrt{(6t)^2 + (6t^2)^2} dt = \int_0^2 \sqrt{36t^2 + 36t^4} dt \\ &= \int_0^2 \sqrt{36t^2} \sqrt{1+t^2} dt = \int_0^2 6|t| \sqrt{1+t^2} dt = 6 \int_0^2 t \sqrt{1+t^2} dt \\ &= 6 \int_1^5 u^{1/2} (\frac{1}{2} du) \quad [u = 1+t^2, du = 2t dt] \\ &= 6 \cdot \frac{1}{2} \cdot \frac{2}{3} [u^{3/2}]_1^5 = 2(5^{3/2} - 1) = 2(5\sqrt{5} - 1) \end{aligned}$$

36.  $x = 2 + 3t, y = \cosh 3t \Rightarrow (dx/dt)^2 + (dy/dt)^2 = 3^2 + (3 \sinh 3t)^2 = 9(1 + \sinh^2 3t) = 9 \cosh^2 3t,$  so

$$L = \int_0^1 \sqrt{9 \cosh^2 3t} dt = \int_0^1 |3 \cosh 3t| dt = \int_0^1 3 \cosh 3t dt = [\sinh 3t]_0^1 = \sinh 3 - \sinh 0 = \sinh 3.$$

37.  $L = \int_{\pi}^{2\pi} \sqrt{r^2 + (dr/d\theta)^2} d\theta = \int_{\pi}^{2\pi} \sqrt{(1/\theta)^2 + (-1/\theta^2)^2} d\theta = \int_{\pi}^{2\pi} \frac{\sqrt{\theta^2 + 1}}{\theta^2} d\theta$

$$\begin{aligned} &\stackrel{24}{=} \left[ -\frac{\sqrt{\theta^2 + 1}}{\theta} + \ln(\theta + \sqrt{\theta^2 + 1}) \right]_{\pi}^{2\pi} = \frac{\sqrt{\pi^2 + 1}}{\pi} - \frac{\sqrt{4\pi^2 + 1}}{2\pi} + \ln\left(\frac{2\pi + \sqrt{4\pi^2 + 1}}{\pi + \sqrt{\pi^2 + 1}}\right) \\ &= \frac{2\sqrt{\pi^2 + 1} - \sqrt{4\pi^2 + 1}}{2\pi} + \ln\left(\frac{2\pi + \sqrt{4\pi^2 + 1}}{\pi + \sqrt{\pi^2 + 1}}\right) \end{aligned}$$

38.  $L = \int_0^{\pi} \sqrt{r^2 + (dr/d\theta)^2} d\theta = \int_0^{\pi} \sqrt{\sin^6(\frac{1}{3}\theta) + \sin^4(\frac{1}{3}\theta) \cos^2(\frac{1}{3}\theta)} d\theta$

$$= \int_0^{\pi} \sin^2(\frac{1}{3}\theta) d\theta = [\frac{1}{2}(\theta - \frac{3}{2} \sin(\frac{2}{3}\theta))]_0^{\pi} = \frac{1}{2}\pi - \frac{3}{8}\sqrt{3}$$

39.  $x = 4\sqrt{t}, y = \frac{t^3}{3} + \frac{1}{2t^2}, 1 \leq t \leq 4 \Rightarrow$

$$\begin{aligned} S &= \int_1^4 2\pi y \sqrt{(dx/dt)^2 + (dy/dt)^2} dt = \int_1^4 2\pi (\frac{1}{3}t^3 + \frac{1}{2}t^{-2}) \sqrt{(2/\sqrt{t})^2 + (t^2 - t^{-3})^2} dt \\ &= 2\pi \int_1^4 (\frac{1}{3}t^3 + \frac{1}{2}t^{-2}) \sqrt{(t^2 + t^{-3})^2} dt = 2\pi \int_1^4 (\frac{1}{3}t^5 + \frac{5}{6} + \frac{1}{2}t^{-5}) dt = 2\pi [\frac{1}{18}t^6 + \frac{5}{6}t - \frac{1}{8}t^{-4}]_1^4 = \frac{471,295}{1024}\pi \end{aligned}$$

40.  $x = 2 + 3t, y = \cosh 3t \Rightarrow (dx/dt)^2 + (dy/dt)^2 = 3^2 + (3 \sinh 3t)^2 = 9(1 + \sinh^2 3t) = 9 \cosh^2 3t,$  so

$$\begin{aligned} S &= \int_0^1 2\pi y ds = \int_0^1 2\pi \cosh 3t \sqrt{9 \cosh^2 3t} dt = \int_0^1 2\pi \cosh 3t |3 \cosh 3t| dt \\ &= \int_0^1 2\pi \cosh 3t \cdot 3 \cosh 3t dt = 6\pi \int_0^1 \cosh^2 3t dt = 6\pi \int_0^1 \frac{1}{2}(1 + \cosh 6t) dt \\ &= 3\pi [t + \frac{1}{6} \sinh 6t]_0^1 = 3\pi(1 + \frac{1}{6} \sinh 6) = 3\pi + \frac{\pi}{2} \sinh 6 \end{aligned}$$

41. For all  $c$  except  $-1$ , the curve is asymptotic to the line  $x = 1$ . For  $c < -1$ , the curve bulges to the right near  $y = 0$ . As  $c$  increases, the bulge becomes smaller, until at  $c = -1$  the curve is the straight line  $x = 1$ . As  $c$  continues to increase, the curve bulges to the left, until at  $c = 0$  there is a cusp at the origin. For  $c > 0$ , there is a loop to the left of the origin, whose size and roundness increase as  $c$  increases. Note that the  $x$ -intercept of the curve is always  $-c$ .

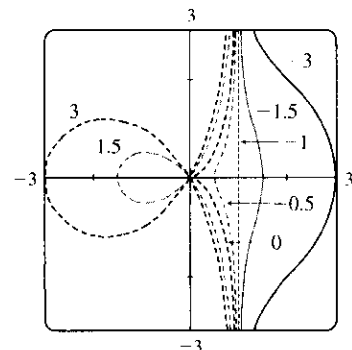

42. For  $a$  close to 0, the graph consists of four thin petals. As  $a$  increases, the petals get fatter, until as  $a \rightarrow \infty$ , each petal occupies almost its entire quarter-circle.

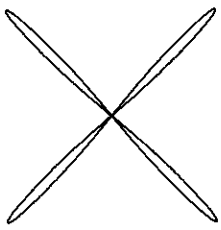

$a = 0.01$

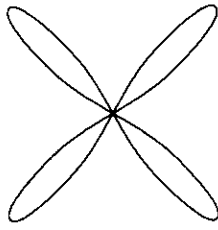

$a = 0.1$

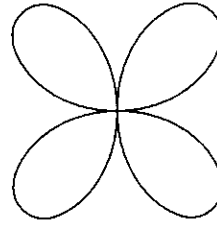

$a = 1$

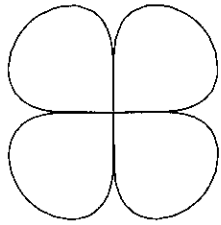

$a = 5$

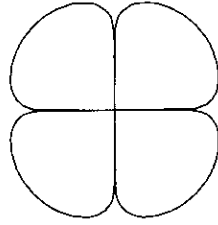

$a = 10$

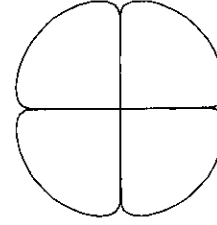

$a = 25$

43.  $\frac{x^2}{9} + \frac{y^2}{8} = 1$  is an ellipse with center  $(0, 0)$ .

$a = 3, b = 2\sqrt{2}, c = 1 \Rightarrow$

foci  $(\pm 1, 0)$ , vertices  $(\pm 3, 0)$ .

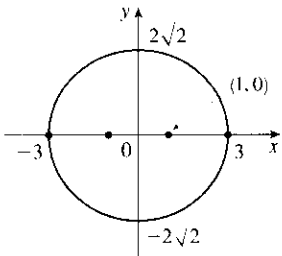

44.  $\frac{x^2}{4} - \frac{y^2}{16} = 1$  is a hyperbola with center  $(0, 0)$ ,

vertices  $(\pm 2, 0)$ ,  $a = 2, b = 4$ ,

$c = \sqrt{16 + 4} = 2\sqrt{5}$ , foci  $(\pm 2\sqrt{5}, 0)$  and

asymptotes  $y = \pm 2x$ .

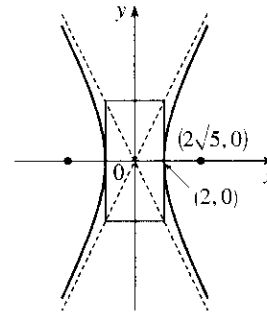

45.  $6y^2 + x - 36y + 55 = 0 \Leftrightarrow$

$6(y^2 - 6y + 9) = -(x + 1) \Leftrightarrow$

$(y - 3)^2 = -\frac{1}{6}(x + 1)$ , a parabola with vertex

$(-1, 3)$ , opening to the left,  $p = -\frac{1}{24} \Rightarrow$  focus

$(-\frac{25}{24}, 3)$  and directrix  $x = -\frac{23}{24}$ .

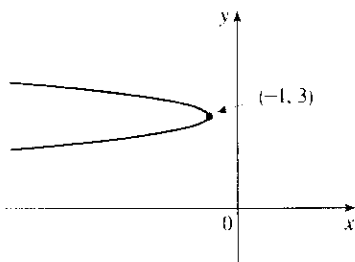

46.  $25(x + 1)^2 + 4(y - 2)^2 = 100 \Leftrightarrow$

$\frac{1}{4}(x + 1)^2 + \frac{1}{25}(y - 2)^2 = 1$  is an ellipse centered

at  $(-1, 2)$  with foci on the line  $x = -1$ , vertices

$(-1, 7)$  and  $(-1, -3)$ ;  $a = 5, b = 2 \Rightarrow$

$c = \sqrt{21} \Rightarrow$  foci  $(-1, 2 \pm \sqrt{21})$ .

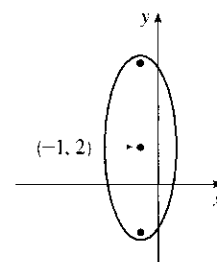

47. The parabola opens upward with vertex  $(0, 4)$  [midway between the focus  $(0, 6)$  and the directrix  $y = 2$ ] and  $p = 2$ , so its equation is  $(x - 0)^2 = 4 \cdot 2(y - 4) \Leftrightarrow x^2 = 8(y - 4)$ .

48. Center is  $(0, 0)$ , and  $c = 5$ ,  $a = 2 \Rightarrow b = \sqrt{21}$ ; foci on  $y$ -axis  $\Rightarrow$  equation of the hyperbola is  $\frac{y^2}{4} - \frac{x^2}{21} = 1$ .

49. The hyperbola has center  $(0, 0)$  and foci on the  $x$ -axis.  $c = 3$  and  $b/a = \frac{1}{2}$  (from the asymptotes)  
 $\Rightarrow 9 = c^2 = a^2 + b^2 = (2b)^2 + b^2 = 5b^2 \Rightarrow b = \frac{3}{\sqrt{5}} \Rightarrow a = \frac{6}{\sqrt{5}} \Rightarrow$  an equation of the hyperbola is  
 $\frac{x^2}{36/5} - \frac{y^2}{9/5} = 1 \Leftrightarrow 5x^2 - 20y^2 = 36$ .

50. Center is  $(3, 0)$ , and  $a = \frac{8}{2} = 4$ ,  $c = 2 \Leftrightarrow b = \sqrt{4^2 - 2^2} = \sqrt{12} \Rightarrow$  an equation of the ellipse is

$$\frac{(x - 3)^2}{12} + \frac{y^2}{16} = 1.$$

51.  $x^2 = -(y - 100)$  has its vertex at  $(0, 100)$ , so one of the vertices of the ellipse is  $(0, 100)$ . Another form of the equation of a parabola is  $x^2 = 4p(y - 100)$  so  $4p(y - 100) = -(y - 100) \Rightarrow 4p = -1 \Rightarrow p = -\frac{1}{4}$ .

Therefore the shared focus is found at  $(0, \frac{399}{4})$  so  $2c = \frac{399}{4} - 0 \Rightarrow c = \frac{399}{8}$  and the center of the ellipse is  $(0, \frac{399}{8})$ . So  $a = 100 - \frac{399}{8} = \frac{401}{8}$  and  $b^2 = a^2 - c^2 = \frac{401^2 - 399^2}{8^2} = 25$ . So the equation of the ellipse is

$$\frac{x^2}{b^2} + \frac{(y - \frac{399}{8})^2}{a^2} = 1 \Rightarrow \frac{x^2}{25} + \frac{(y - \frac{399}{8})^2}{(\frac{401}{8})^2} = 1 \text{ or } \frac{x^2}{25} + \frac{(8y - 399)^2}{160,801} = 1.$$

52.  $\frac{x^2}{a^2} + \frac{y^2}{b^2} = 1 \Rightarrow \frac{2x}{a^2} + \frac{2y}{b^2} \frac{dy}{dx} = 0 \Rightarrow \frac{dy}{dx} = -\frac{b^2 x}{a^2 y}$ . Therefore  $\frac{dy}{dx} = m \Leftrightarrow y = -\frac{b^2 x}{a^2 m}$ .

Combining this condition with  $\frac{x^2}{a^2} + \frac{y^2}{b^2} = 1$ , we find that  $x = \pm \frac{a^2 m}{\sqrt{a^2 m^2 + b^2}}$ . In other words, the two points on

the ellipse where the tangent has slope  $m$  are  $\left( \pm \frac{a^2 m}{\sqrt{a^2 m^2 + b^2}}, \mp \frac{b^2}{\sqrt{a^2 m^2 + b^2}} \right)$ . The tangent lines at

these points have the equations  $y \pm \frac{b^2}{\sqrt{a^2 m^2 + b^2}} = m \left( x \mp \frac{a^2 m}{\sqrt{a^2 m^2 + b^2}} \right)$  or

$$y = mx \mp \frac{a^2 m^2}{\sqrt{a^2 m^2 + b^2}} \mp \frac{b^2}{\sqrt{a^2 m^2 + b^2}} = mx \mp \sqrt{a^2 m^2 + b^2}.$$

53. Directrix  $x = 4 \Rightarrow d = 4$ , so  $e = \frac{1}{3} \Rightarrow r = \frac{ed}{1 + e \cos \theta} = \frac{4}{3 + \cos \theta}$ .

54. See the end of the proof of Theorem 11.6.1. If  $e > 1$ , then  $1 - e^2 < 0$  and Equations 11.6.4 become

$$a^2 = \frac{e^2 d^2}{(e^2 - 1)^2} \text{ and } b^2 = \frac{e^2 d^2}{e^2 - 1}, \text{ so } \frac{b^2}{a^2} = e^2 - 1. \text{ The asymptotes } y = \pm \frac{b}{a}x \text{ have slopes } \pm \frac{b}{a} = \pm \sqrt{e^2 - 1}, \text{ so}$$

the angles they make with the polar axis are  $\pm \tan^{-1} [\sqrt{e^2 - 1}] = \cos^{-1} (\pm 1/e)$ .

55. In polar coordinates, an equation for the circle is  $r = 2a \sin \theta$ . Thus, the coordinates of  $Q$  are

$$x = r \cos \theta = 2a \sin \theta \cos \theta \text{ and } y = r \sin \theta = 2a \sin^2 \theta. \text{ The coordinates of } R \text{ are } x = 2a \cot \theta \text{ and } y = 2a.$$

Since  $P$  is the midpoint of  $QR$ , we use the midpoint formula to get  $x = a(\sin \theta \cos \theta + \cot \theta)$  and

$$y = a(1 + \sin^2 \theta).$$

## □ PROBLEMS PLUS

1.  $x = \int_1^t \frac{\cos u}{u} du$ ,  $y = \int_1^t \frac{\sin u}{u} du$ , so by FTC1, we have  $\frac{dx}{dt} = \frac{\cos t}{t}$  and  $\frac{dy}{dt} = \frac{\sin t}{t}$ . Vertical tangent lines

occur when  $\frac{dx}{dt} = 0 \Leftrightarrow \cos t = 0$ . The parameter value corresponding to  $(x, y) = (0, 0)$  is  $t = 1$ , so the

nearest vertical tangent occurs when  $t = \frac{\pi}{2}$ . Therefore, the arc length between these points is

$$L = \int_1^{\pi/2} \sqrt{\left(\frac{dx}{dt}\right)^2 + \left(\frac{dy}{dt}\right)^2} dt = \int_1^{\pi/2} \sqrt{\frac{\cos^2 t}{t^2} + \frac{\sin^2 t}{t^2}} dt = \int_1^{\pi/2} \frac{dt}{t} = [\ln t]_1^{\pi/2} = \ln \frac{\pi}{2}$$

2. (a) The curve  $x^4 + y^4 = x^2 + y^2$  is symmetric about both axes and about the line  $y = x$  (since interchanging  $x$  and  $y$  does not change the equation) so we need only consider  $y \geq x \geq 0$  to begin with. Implicit differentiation

gives  $4x^3 + 4y^3y' = 2x + 2yy'$   $\Rightarrow y' = \frac{x(1 - 2x^2)}{y(2y^2 - 1)}$   $\Rightarrow y' = 0$  when  $x = 0$  and when  $x = \pm\frac{1}{\sqrt{2}}$ . If

$x = 0$ , then  $y^4 = y^2 \Rightarrow y^2(y^2 - 1) = 0 \Rightarrow y = 0$  or  $\pm 1$ . The point  $(0, 0)$  can't be a highest or lowest

point because it is isolated. [If  $-1 < x < 1$  and  $-1 < y < 1$ , then  $x^4 < x^2$  and  $y^4 < y^2 \Rightarrow$

$x^4 + y^4 < x^2 + y^2$ , except for  $(0, 0)$ .] If  $x = \frac{1}{\sqrt{2}}$ , then  $x^2 = \frac{1}{2}$ ,  $x^4 = \frac{1}{4}$ , so  $\frac{1}{4} + y^4 = \frac{1}{2} + y^2 \Rightarrow$

$4y^4 - 4y^2 - 1 = 0 \Rightarrow y^2 = \frac{4 \pm \sqrt{16+16}}{8} = \frac{1 \pm \sqrt{2}}{2}$ . But  $y^2 > 0$ , so  $y^2 = \frac{1 + \sqrt{2}}{2} \Rightarrow$

$y = \pm\sqrt{\frac{1}{2}(1 + \sqrt{2})}$ . Near the point  $(0, 1)$ , the denominator of  $y'$  is positive and the numerator changes from

negative to positive as  $x$  increases through 0, so  $(0, 1)$  is a local minimum point. At  $\left(\frac{1}{\sqrt{2}}, \sqrt{\frac{1 + \sqrt{2}}{2}}\right)$ ,

$y'$  changes from positive to negative, so that point gives a maximum. By symmetry, the highest points on the

curve are  $\left(\pm\frac{1}{\sqrt{2}}, \sqrt{\frac{1 + \sqrt{2}}{2}}\right)$  and the lowest points are  $\left(\pm\frac{1}{\sqrt{2}}, -\sqrt{\frac{1 + \sqrt{2}}{2}}\right)$ .

(b) We use the information from part (a), together with symmetry with respect to the axes and the lines  $y = \pm x$ , to sketch the curve.

(c) In polar coordinates,  $x^4 + y^4 = x^2 + y^2$  becomes

$r^4 \cos^4 \theta + r^4 \sin^4 \theta = r^2$  or  $r^2 = 1 / (\cos^4 \theta + \sin^4 \theta)$ . By the

symmetry shown in part (b), the area enclosed by the curve is

$$A = 8 \int_0^{\pi/4} \frac{1}{2} r^2 d\theta = 4 \int_0^{\pi/4} \frac{d\theta}{\cos^4 \theta + \sin^4 \theta} \stackrel{\text{CAS}}{=} \sqrt{2}\pi.$$

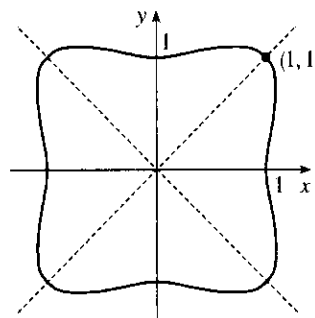

3. In terms of  $x$  and  $y$ , we have  $x = r \cos \theta = (1 + c \sin \theta) \cos \theta = \cos \theta + c \sin \theta \cos \theta = \cos \theta + \frac{1}{2}c \sin 2\theta$  and  $y = r \sin \theta = (1 + c \sin \theta) \sin \theta = \sin \theta + c \sin^2 \theta$ . Now  $-1 \leq \sin \theta \leq 1 \Rightarrow -1 \leq \sin \theta + c \sin^2 \theta \leq 1 + c \leq 2$ , so  $-1 \leq y \leq 2$ . Furthermore,  $y = 2$  when  $c = 1$  and  $\theta = \frac{\pi}{2}$ , while  $y = -1$  for  $c = 0$  and  $\theta = \frac{3\pi}{2}$ . Therefore, we need a viewing rectangle with  $-1 \leq y \leq 2$ .

To find the  $x$ -values, look at the equation  $x = \cos \theta + \frac{1}{2}c \sin 2\theta$  and use the fact that  $\sin 2\theta \geq 0$  for  $0 \leq \theta \leq \frac{\pi}{2}$  and  $\sin 2\theta \leq 0$  for  $-\frac{\pi}{2} \leq \theta \leq 0$ . [Because  $r = 1 + c \sin \theta$  is symmetric about the  $y$ -axis, we only need to consider  $-\frac{\pi}{2} \leq \theta \leq \frac{\pi}{2}$ .] So for  $-\frac{\pi}{2} \leq \theta \leq 0$ ,  $x$  has a maximum value when  $c = 0$  and then  $x = \cos \theta$  has a maximum value of 1 at  $\theta = 0$ . Thus, the maximum value of  $x$  must occur on  $[0, \frac{\pi}{2}]$  with  $c = 1$ . Then  $x = \cos \theta + \frac{1}{2} \sin 2\theta \Rightarrow \frac{dx}{d\theta} = -\sin \theta + \cos 2\theta = -\sin \theta + 1 - 2 \sin^2 \theta \Rightarrow \frac{dx}{d\theta} = -(2 \sin \theta - 1)(\sin \theta + 1) = 0$  when  $\sin \theta = -1$  or  $\frac{1}{2}$  (but  $\sin \theta \neq -1$  for  $0 \leq \theta \leq \frac{\pi}{2}$ ). If  $\sin \theta = \frac{1}{2}$ , then  $\theta = \frac{\pi}{6}$  and  $x = \cos \frac{\pi}{6} + \frac{1}{2} \sin \frac{\pi}{3} = \frac{3}{4}\sqrt{3}$ . Thus, the maximum value of  $x$  is  $\frac{3}{4}\sqrt{3}$ , and, by symmetry, the minimum value is  $-\frac{3}{4}\sqrt{3}$ . Therefore, the smallest viewing rectangle that contains every member of the family of polar curves  $r = 1 + c \sin \theta$ , where  $0 \leq c \leq 1$ , is  $[-\frac{3}{4}\sqrt{3}, \frac{3}{4}\sqrt{3}] \times [-1, 2]$ .

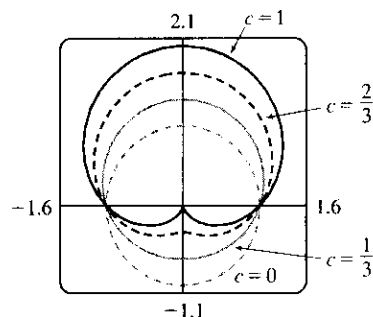

4. (a) Let us find the polar equation of the path of the bug that starts in the upper right corner of the square. If the polar coordinates of this bug, at a particular moment, are  $(r, \theta)$ , then the polar coordinates of the bug that it is crawling toward must be  $(r, \theta + \frac{\pi}{2})$ . (The next bug must be the same distance from the origin and the angle between the lines joining the bugs to the pole must be  $\frac{\pi}{2}$ .) The Cartesian coordinates of the first bug are  $(r \cos \theta, r \sin \theta)$  and for the second

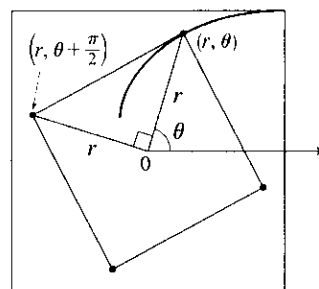

bug we have  $x = r \cos(\theta + \frac{\pi}{2}) = -r \sin \theta$ ,  $y = r \sin(\theta + \frac{\pi}{2}) = r \cos \theta$ . So the slope of the line joining the bugs is  $\frac{r \cos \theta - r \sin \theta}{-r \sin \theta - r \cos \theta} = \frac{\sin \theta - \cos \theta}{\sin \theta + \cos \theta}$ . This must be equal to the slope of the tangent line at  $(r, \theta)$ , so by

Equation 11.3.3 we have  $\frac{(dr/d\theta) \sin \theta + r \cos \theta}{(dr/d\theta) \cos \theta - r \sin \theta} = \frac{\sin \theta - \cos \theta}{\sin \theta + \cos \theta}$ . Solving for  $\frac{dr}{d\theta}$ , we get

$$\frac{dr}{d\theta} \sin^2 \theta + \frac{dr}{d\theta} \sin \theta \cos \theta + r \sin \theta \cos \theta + r \cos^2 \theta = \frac{dr}{d\theta} \sin \theta \cos \theta - \frac{dr}{d\theta} \cos^2 \theta - r \sin^2 \theta + r \sin \theta \cos \theta \Rightarrow \frac{dr}{d\theta} (\sin^2 \theta + \cos^2 \theta) + r (\cos^2 \theta + \sin^2 \theta) = 0 \Rightarrow \frac{dr}{d\theta} = -r.$$

Solving this differential equation as a separable equation (as in Section 10.3), or using Theorem 10.4.2 with  $k = -1$ , we get  $r = Ce^{-\theta}$ . To determine  $C$  we use the fact that, at its starting position,  $\theta = \frac{\pi}{4}$  and  $r = \frac{1}{\sqrt{2}}a$ , so  $\frac{1}{\sqrt{2}}a = Ce^{-\pi/4} \Rightarrow C = \frac{1}{\sqrt{2}}ae^{\pi/4}$ .

Therefore, a polar equation of the bug's path is  $r = \frac{1}{\sqrt{2}}ae^{\pi/4}e^{-\theta}$  or  $r = \frac{1}{\sqrt{2}}ae^{(\pi/4)-\theta}$ .

(b) The distance traveled by this bug is  $L = \int_{\pi/4}^{\infty} \sqrt{r^2 + (dr/d\theta)^2} d\theta$ , where  $\frac{dr}{d\theta} = \frac{a}{\sqrt{2}} e^{\pi/4} (-e^{-\theta})$  and so

$$r^2 + (dr/d\theta)^2 = \frac{1}{2}a^2 e^{\pi/2} e^{-2\theta} + \frac{1}{2}a^2 e^{\pi/2} e^{-2\theta} = a^2 e^{\pi/2} e^{-2\theta}$$

Thus

$$\begin{aligned} L &= \int_{\pi/4}^{\infty} a e^{\pi/4} e^{-\theta} d\theta = a e^{\pi/4} \lim_{t \rightarrow \infty} \int_{\pi/4}^t e^{-\theta} d\theta = a e^{\pi/4} \lim_{t \rightarrow \infty} [-e^{-\theta}]_{\pi/4}^t \\ &= a e^{\pi/4} \lim_{t \rightarrow \infty} [e^{-\pi/4} - e^{-t}] = a e^{\pi/4} e^{-\pi/4} = a \end{aligned}$$

5. (a) If  $(a, b)$  lies on the curve, then there is some parameter value  $t_1$  such that  $\frac{3t_1}{1+t_1^3} = a$  and  $\frac{3t_1^2}{1+t_1^3} = b$ . If

$t_1 = 0$ , the point is  $(0, 0)$ , which lies on the line  $y = x$ . If  $t_1 \neq 0$ , then the point corresponding to  $t = \frac{1}{t_1}$  is

$$\text{given by } x = \frac{3(1/t_1)}{1+(1/t_1)^3} = \frac{3t_1^2}{t_1^3+1} = b, y = \frac{3(1/t_1)^2}{1+(1/t_1)^3} = \frac{3t_1}{t_1^3+1} = a. \text{ So } (b, a) \text{ also lies on the curve.}$$

[Another way to see this is to do part (e) first; the result is immediate.] The curve intersects the line  $y = x$  when

$$\frac{3t}{1+t^3} = \frac{3t^2}{1+t^3} \Rightarrow t = t^2 \Rightarrow t = 0 \text{ or } 1, \text{ so the points are } (0, 0) \text{ and } \left(\frac{3}{2}, \frac{3}{2}\right).$$

$$(b) \frac{dy}{dt} = \frac{(1+t^3)(6t) - 3t^2(3t^2)}{(1+t^3)^2} = \frac{6t - 3t^4}{(1+t^3)^2} = 0 \text{ when } 6t - 3t^4 = 3t(2 - t^3) = 0 \Rightarrow t = 0 \text{ or } t = \sqrt[3]{2},$$

so there are horizontal tangents at  $(0, 0)$  and  $(\sqrt[3]{2}, \sqrt[3]{4})$ . Using the symmetry from part (a), we see that there are vertical tangents at  $(0, 0)$  and  $(\sqrt[3]{4}, \sqrt[3]{2})$ .

(c) Notice that as  $t \rightarrow -1^+$ , we have  $x \rightarrow -\infty$  and  $y \rightarrow \infty$ . As  $t \rightarrow -1^-$ , we have  $x \rightarrow \infty$  and  $y \rightarrow -\infty$ . Also

$$y - (-x - 1) = y + x + 1 = \frac{3t + 3t^2 + (1+t^3)}{1+t^3} = \frac{(t+1)^3}{1+t^3} = \frac{(t+1)^2}{t^2 - t + 1} \rightarrow 0 \text{ as } t \rightarrow -1. \text{ So}$$

$y = -x - 1$  is a slant asymptote.

$$(d) \frac{dx}{dt} = \frac{(1+t^3)(3) - 3t(3t^2)}{(1+t^3)^2} = \frac{3 - 6t^3}{(1+t^3)^2} \text{ and from part (b) we have } \frac{dy}{dt} = \frac{6t - 3t^4}{(1+t^3)^2}.$$

$$\text{So } \frac{dy}{dx} = \frac{dy/dt}{dx/dt} = \frac{t(2-t^3)}{1-2t^3}. \text{ Also}$$

$$\frac{d^2y}{dx^2} = \frac{\frac{d}{dt} \left( \frac{dy}{dx} \right)}{dx/dt} = \frac{2(1+t^3)^4}{3(1-2t^3)^3} > 0 \Leftrightarrow t < \frac{1}{\sqrt[3]{2}}. \text{ So}$$

the curve is concave upward there and has a minimum point

at  $(0, 0)$  and a maximum point at  $(\sqrt[3]{2}, \sqrt[3]{4})$ . Using this

together with the information from parts (a), (b), and (c), we sketch the curve.

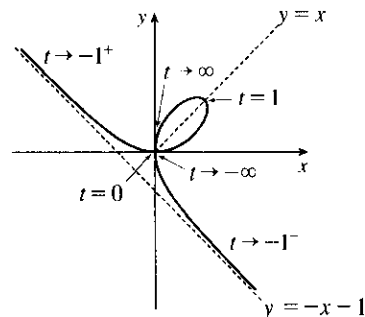

$$(e) x^3 + y^3 = \left(\frac{3t}{1+t^3}\right)^3 + \left(\frac{3t^2}{1+t^3}\right)^3 = \frac{27t^3 + 27t^6}{(1+t^3)^3} = \frac{27t^3(1+t^3)}{(1+t^3)^3} = \frac{27t^3}{(1+t^3)^2} \text{ and}$$

$$3xy = 3\left(\frac{3t}{1+t^3}\right)\left(\frac{3t^2}{1+t^3}\right) = \frac{27t^3}{(1+t^3)^2}, \text{ so } x^3 + y^3 = 3xy.$$

(f) We start with the equation from part (e) and substitute  $x = r \cos \theta$ ,  $y = r \sin \theta$ . Then  $x^3 + y^3 = 3xy \Rightarrow r^3 \cos^3 \theta + r^3 \sin^3 \theta = 3r^2 \cos \theta \sin \theta$ . For  $r \neq 0$ , this gives  $r = \frac{3 \cos \theta \sin \theta}{\cos^3 \theta + \sin^3 \theta}$ . Dividing numerator and

denominator by  $\cos^3 \theta$ , we obtain  $r = \frac{3\left(\frac{1}{\cos \theta}\right)\frac{\sin \theta}{\cos \theta}}{1 + \frac{\sin^3 \theta}{\cos^3 \theta}} = \frac{3 \sec \theta \tan \theta}{1 + \tan^3 \theta}$ .

(g) The loop corresponds to  $\theta \in (0, \frac{\pi}{2})$ , so its area is

$$\begin{aligned} A &= \int_0^{\pi/2} \frac{r^2}{2} d\theta = \frac{1}{2} \int_0^{\pi/2} \left(\frac{3 \sec \theta \tan \theta}{1 + \tan^3 \theta}\right)^2 d\theta = \frac{9}{2} \int_0^{\pi/2} \frac{\sec^2 \theta \tan^2 \theta}{(1 + \tan^3 \theta)^2} d\theta \\ &= \frac{9}{2} \int_0^{\infty} \frac{u^2 du}{(1 + u^3)^2} \quad [\text{let } u = \tan \theta] = \lim_{b \rightarrow \infty} \frac{9}{2} \left[-\frac{1}{3} (1 + u^3)^{-1}\right]_0^b = \frac{3}{2} \end{aligned}$$

(h) By symmetry, the area between the folium and the line  $y = -x - 1$  is equal to the enclosed area in the third quadrant, plus twice the enclosed area in the fourth quadrant. The area in the third quadrant is  $\frac{1}{2}$ , and since

$$y = -x - 1 \Rightarrow r \sin \theta = -r \cos \theta - 1 \Rightarrow r = -\frac{1}{\sin \theta + \cos \theta}, \text{ the area in the fourth quadrant is}$$

$$\frac{1}{2} \int_{-\pi/2}^{-\pi/4} \left[ \left(-\frac{1}{\sin \theta + \cos \theta}\right)^2 - \left(\frac{3 \sec \theta \tan \theta}{1 + \tan^3 \theta}\right)^2 \right] d\theta \stackrel{\text{CAS}}{=} \frac{1}{2}. \text{ Therefore, the total area is } \frac{1}{2} + 2\left(\frac{1}{2}\right) = \frac{3}{2}.$$