

TACHOMETERS

Tachometers are devices for measuring the rotation speed of machine shafts, relative to a referential, which is generally the machine's stator. Tachometers get their name from the Greek words *takhys*, meaning "quick," and *metron*, meaning "measure." Therefore, etymologically, a tachometer is a device capable of measuring a speed. However, in the technical context, linear velocity meters generally are not referred to as tachometers, and the word is reserved for shaft rotation speed meters.

Moving vehicles can have translation movements and rotation movements relative to a referential. When guidance and navigation problems are considered, these movements must be sensed and their speed measured. The devices for measuring these rotational movement speeds of the vehicle relative to a fixed referential of inertia are generally called rotation rate meters or gyrometers and are not referred to as tachometers.

A rotation speed can be obtained from an angular position sensor by means of a time derivation. However, derivation increases measurement errors and noise that may exist in the position measurement. The speed can also be obtained from an angular acceleration sensor by means of a time integration. However, integration has an initial value undetermination and may also cause the integrator to wind up due to any offset that may exist in the acceleration measurement. Therefore, even when a mechanical system has angular position or acceleration sensors, the speed of rotation is generally measured independently with some kind of tachometer.

Tachometers may be classified in several ways. One possible classification is based on the type of the tachometer's output quantity, which may be

1. A voltage value (amplitude or rms [root mean square] value): tachogenerators
2. A visual indication by a pointer mechanical position: drag-cup and fly-ball tachometers
3. A frequency value (or time value): inductive, Hall effect, optical pulse, strain gauge, variable capacitance, and switch tachometers; or stroboscopes

In this article, the description of the several types of tachometers follows an order suggested by this classification. Note that some tachometers may fit into more than one class, depending on the way their output is used. For instance, tachogenerators and inductive pulse tachometers may fit into class 1 or 3; stroboscopes may be classified as class 2 or 3.

Another classification is based on the principle of physics that underlies its operation. From this viewpoint there are

1. Electrodynamical tachometers: tachogenerators, drag cup, inductive pulse
2. Mechanical tachometers: the fly-ball

3. Magnetic tachometers: the Hall effect
4. Optical tachometers: the optical pulse and the stroboscope

Tachometers may be permanently installed and fixed on the machine group for constant monitoring of speed. For this purpose, any kind of tachometer but a stroboscope will do. Or they may be intermittently used to check the speed, without the need for permanent mechanical setting. For this purpose, the stroboscope and the optical reflected pulse tachometers are suitable, as they do not need moving pieces and only need an appropriate light source to be pointed at the machine to get a speed reading. Although not so well adapted, other types of tachometers with rotating internal parts may be found in portable tachometers. In these portables, the axle of the rotating parts protrudes from the apparatus box and has a rubber wheel on the end of it. To use the meter, the operator must put this wheel in contact with the rotating shaft, which then transmits the motion to the inner mechanisms of the device. The output then appears on the tachometer display. Care must be taken to avoid getting grease and dirt on the rubber wheel, which would cause it to slip on the shaft.

A vehicle's rotational speed is generally much slower than a machine shaft rotation. This vehicle motion speed can be measured with two kinds of sensors: the rate gyroscope, based on the mechanical conservation of angular momentum; and optical gyros, based on the interference of two optical beams whose wavelengths are modified differently by the motion. Although these are not considered to be tachometers, they do measure a rotation speed and therefore will be described later in this article.

TACHOGENERATORS

Tachogenerators are small auxiliary machines acting as generators, driven by the shaft of the group whose rotation speed is to be measured. They provide an output voltage that has certain characteristics (constant value, rms value, frequency, etc.) proportional to that speed. There are several types of tachogenerators.

Dc Tachogenerators

Direct current (dc) tachometers are essentially dc generators (dynamos). Driven by a rotating axle, they provide an output dc voltage proportional to the rotation speed. A dynamo (Fig. 1) is composed of an iron rotor (armature), where a number of copper coils are wound, rotating inside a stator (inductor), which creates a magnetic induction flux ϕ that is stationary in space and constant in time. This induction flux can be generated by extra coils in the stator, which act as electromagnets being fed by direct currents; or it can be created by permanent magnets in the stator poles.

According to Faraday's law of induction, in each rotating coil an alternative emf (electromotive force) $e(t)$ is induced whose maximum is $E = kN\phi$, where k is a constant dependent on the way the device is constructed and N is the rotating speed in rpm.

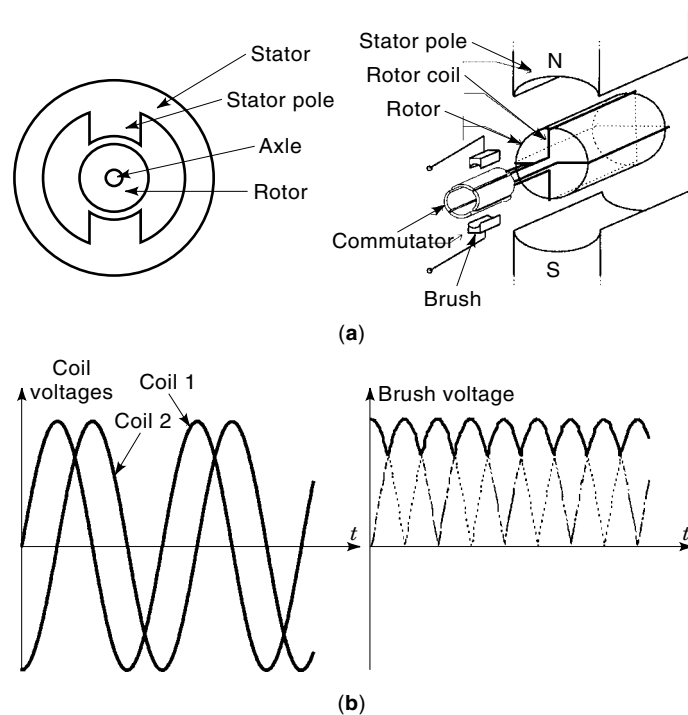

Figure 1. Dc tachogenerator (dynamo). (a) Internal constitution. (b) Voltages.

The coils of the rotor have their terminals connected to different insulated copper segments of a cylinder, coaxial with the rotor, called the commutator [Fig. 1(a)]. A pair of stationary carbon brushes slips over the segments, with little friction. The brushes are in contact with only one pair of segments at a time and, therefore, they establish electric contact between an outside stationary circuit and the two terminals of only one coil each time.

The brushes are positioned so that the two segments come in contact with the two terminals of a coil exactly when that coil's emf goes through its maximum value. As the rotor's rotation tends to decrease that emf, it also moves those segments away from the brushes, making way for new segments, which establish contact with the next coil where the emf is now at a maximum. In this way, the commutator acts like a mechanical rectifier, picking up only the maximum value of emf [Fig. 1(b)]. So the output voltage of the dynamo, measured between the stationary brushes at no load condition, is $V = E = kN\phi$.

Keeping the flux ϕ constant, the voltage is proportional to the rotation speed N . As can be seen by Faraday's law, inversion of the rotation direction (correspondent to a switch of algebraic sign of N) causes an inversion of the output voltage polarity. So the voltage is a measure of both direction and magnitude of the rotational speed.

As the number of armature coils is finite, the brushes are in contact with them not only at the moments when their emf is at a maximum, but also a little before and a little after that. Therefore, the voltage at the brushes is not exactly constant but has a ripple, which decreases as the number of coils built into the rotor increases. In practice, other sources of ripple exist, such as eccentricities, asymmetries, and irregularities of the brushes contacts. The ratio of the amplitude

of that ripple (difference between maximum and minimum) to the mean voltage value is called undulation and is an index of performance of the tachometer. This undulation value can reach as high as 2%.

Typical sensitivities of the dc tachometer generators are about 5 V to 10 V per 1000 rpm, with ranges of typically 0–5000 rpm up to 0–10,000 rpm.

To behave as a tachometer, the dynamo must be kept at constant flux condition. So the flux is usually generated by permanent magnets made of appropriate alloys or sintered materials; and no load current must be allowed, so the tachometer must only be connected to high-impedance voltmeter devices.

To minimize the mechanical load of the tachometer on the group, the rotor is built with as little a moment of inertia as possible. One typical construction solution is to wind the armature coils over a hollow plastic rotor while the magnetic circuit is completed by an iron stationary cylinder inside the rotor.

Dc tachometers have the advantage of furnishing a dc signal proportional to the speed, with nonlinearity usually less than 1% of full scale and with a polarity that shows the direction of movement. Therefore, they are appropriate for control purposes. However, they have the disadvantage of having a voltage ripple, which may demand electric filtering, causing a time delay that may be inconvenient. Another disadvantage is that the construction of the windings and of the commutator is difficult, making the devices expensive. For these reasons, these devices tend to be replaced by digital, pulsed types.

Ac Tachogenerators

Alternating current (ac) tachometers are ac generators coupled with the group, producing an ac voltage that is a measure of the speed. Ac machines of two types, synchronous and induction, can be used to build two corresponding types of ac tachogenerators.

Ac Synchronous Tachogenerators. The ac synchronous generator, also called an alternator, generates an ac voltage that is synchronized with the rotation speed of the rotor. Generally it is built with the inductor in its rotor and the induced coils in the stator. By means of dc rotor currents or permanent magnets at the poles, the rotor creates an induction field B in the airgap, which is constant in time and is fixed with respect to the rotor. The revolution movement of the rotor inside the stator causes a similar rotation of the magnetic field. This field is expected to have sinusoidal spatial distribution.

The induction flux ψ linked to a coil in the stator with n turns is $\psi = n\phi \cos \alpha$, where ϕ is the simple flux produced by a rotor pair of poles and α is the electric angle between the coil and the pole magnetic axes. With the rotor rotating at an angular speed ω , the angle is $\alpha = \omega t$. However, if the rotor has p pairs of poles, the magnetic north-south sequence passing through the coil in the stator occurs p times in each mechanical revolution. Then its electric frequency is $p\omega$, and then $\alpha = p\omega t$. According to Faraday's law of induction, the emf induced in the coil is then

$$e(t) = (p\omega)n\phi \cos(p\omega t\pi/2)$$

If no current is drawn from that coil, its no load voltage equals this emf. So in the static coil, an alternative voltage is produced, with both its magnitude and its frequency proportional to the rotating speed, provided the flux ϕ is kept constant. To keep a constant flux ϕ , the ac synchronous tachogenerators have permanent magnets on the rotor, built with the same technologies referred to in the section on dc tachometers; and their stator coils must be connected to high-impedance voltmeter devices. To increase the induced voltages, they generally have more than one pair of poles, typically four. Their sensitivities and ranges are similar to those of the dc tachometers.

Ac synchronous tachogenerators are less expensive than the dc tachometers because they do not need the costly commutator. The speed information is obtained by measuring the tachogenerator voltage amplitude with an ac voltmeter (sensitive to rms values, or a dc voltmeter provided the voltage is electronically rectified). For control purposes, the alternative voltage must be conditioned by means of an ac/dc converter and filtering circuit, which may cause undesirable delays.

Alternatively, the rotating speed may be obtained by measuring the voltage frequency, which is necessarily p times the speed in rps. This is a more accurate means of measurement, if a digital frequency meter is used, and is appropriate for use in digital measuring and control systems.

Neither the voltage nor the frequency measures give any information about the direction of the rotation. This is a disadvantage of the ac synchronous tachogenerators when compared with the dc ones. To overcome this limitation, synchronous tachogenerators with two stator coils are used. Voltages induced in both coils are equal in amplitude and frequency but have different phases (typically they differ by 90°). A circuit sensing which one is leading and which one is lagging provides the information about the direction of rotation.

Ac Induction Tachogenerators. Ac induction tachogenerator tachometers have the structure of a two-phase induction motor: The stator has two different coils whose magnetic axes are perpendicular in space; the rotor has no salient poles and also has a two-phase winding, which is kept short circuited. Indeed, as all the rotor conductors are short circuited at their terminals, there is no need to individualize the coils. These can be replaced by a uniform distribution of rotor conductors, forming the so-called squirrel cage rotor. The currents induced in the cage, regardless of the number of its conductors, have the same magnetic effect as a two-phase winding. The same effect is obtained with an even smoother current distribution, like the one obtained in a continuous conducting sleeve over the rotor, the so-called drag-cup rotor.

One of the stator coils is fed with a sinusoidal voltage $u_1 = U \cos(\omega t)$ while the other is kept in open circuit. Because the two coils are orthogonal, the voltage induced in the second coil will be null if the rotor is stopped. However, if the rotor is moving with angular velocity Ω , the currents induced in it will cause a magnetic link with the second coil. If resistive voltages can be neglected compared with inductive ones, then a voltage will be induced in the second coil that is $u_2 = \Omega k U \cos(\omega t + \pi/2)$, where k is a constant that depends on the construction of the device. That is, a voltage is obtained that has the same frequency as the feeding voltage and whose amplitude is proportional to the speed to be measured. The direction of the rotation is obtained by comparing the phases of

u_1 and u_2 . Indeed, reversing the direction of the movement is equivalent to changing the algebraic sign of Ω , which is the same as switching the phase of u_2 by 180° .

The preceding expressions assume that the second coil is kept without current, so a high-impedance voltmeter device must be used. A constant rotating speed Ω is also assumed; this means that if Ω changes, the frequency of the changes of Ω must not approach the frequency ω of the input voltage. This is generally the case. For the most common cases, power line frequency is used to feed the tachometer, as the main machine mechanical speed cannot have rapid oscillations on the order of tens of hertz.

This type of tachometer may be built with a squirrel cage rotor, thus providing an inexpensive instrument. However, the drag-cup rotor is more common because it provides better results with the advantage of having a lesser inertia than the former. The drag-cup rotor consists of a hollow sleeve of aluminum providing the rotor electric circuit. The cup rotates around a stationary iron core that completes the magnetic circuit.

With drag-cup rotors, ac induction tachometers can have an accuracy up to 0.1% of full-scale deflection, with ranges typically between 0 rpm and 5000 rpm and sensitivities of up to 10 V per 1000 rpm.

THE DRAG-CUP TACHOMETERS

The drag-cup tachometer (Fig. 2), also called eddy-current tachometer, is not a tachogenerator. It does not furnish an electric signal proportional to the speed. Instead, its response is a visual indication of speed by means of the position of a needle over a scale. It can be used in addition to any position transducer if an electric signal is needed, but this is not a common solution. The drag-cup tachometer is a very common device and is generally used as a speed and engine rpm indicator in automobiles, airplanes, and other vehicles.

The instrument consists of a rotating cylindrical permanent magnet driven by the rotating shaft. The magnet rotates inside a hollow conductive sleeve (a cup, usually made of aluminum), coaxial with the shaft. This cup can also rotate, but its movement is restrained by a spring. Surrounding the conductive cup, a fixed hollow iron cylinder closes the magnetic circuit of the magnet's induction field lines.

When the magnet rotates, its revolving magnetic field induces eddy currents in the conductive cup. The amplitude of

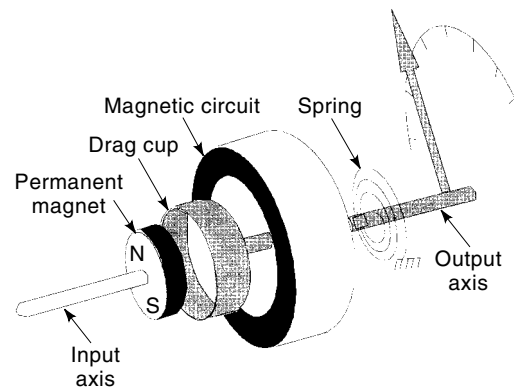

Figure 2. The drag-cup tachometer (exploded view).

these currents is proportional to the time derivative of the induction flux (that is, proportional to the rotation speed). These currents interact with the magnetic field and generate an electrodynamic torque proportional to the field amplitude (which is constant) and to the currents' amplitude. Therefore, the torque generated is proportional to the rotating speed. This electrodynamic torque causes a displacement of the cup to a position where the spring resisting torque balances the first one. The cup is attached to a pointer, whose position on a scale is an image of the equilibrium position of the cup, thus furnishing a reading of the speed.

This mechanism is similar to an induction motor: The rotating field of the permanent magnet is similar to the rotating field generated by a current-fed polyphase stator winding, with currents of a frequency similar to the rotating speed of the magnet. The cup behaves as a short-circuited rotor at standstill, experiencing the starting torque. Under these conditions, induction motor equations show that the torque is approximately proportional to the stator frequency (in this case, to the speed of the magnet), provided the currents induced in the cup do not have magnetic effects comparable with the field of the permanent magnet.

The permanent magnet used in drag-cup tachometers generally is made of Al-Ni, or other appropriate alloys, and has up to five pairs of poles. The dependence of its magnetic properties on the temperature is corrected by means of a thermoperm compensating disk. This is a disk made of a material whose magnetic conductivity depends on the temperature, placed close to the cylindrical magnet and partially shunting it to a degree that also depends on the temperature. The dependencies practically cancel each other.

Drag-cup tachometers are used in speed ranges up to 10,000 rpm and have a measuring accuracy on the order of 1%.

FLY-BALL TACHOMETERS

The fly-ball tachometer is a mechanical device that has been in use for a long time as a speed-governing device for thermic engines (watt regulator). Used as a tachometer, it gives a visual information of the speed, positioning a pointer on a scale. Position sensors can be added to convert the pointer position into an electrical signal if this is needed.

The fly-ball tachometer consists of two massive spheres, connected through a system of levers to the shaft. The shaft rotation causes the spheres to rotate around it. The centrifugal force drives the spheres away from the shaft, but their radial displacement is restrained by the levers acting against a restitution spring. At equilibrium, the spheres rotate at a distance where the spring force and the centrifugal force are equal. This distance is shown by the position of a pointer driven by the lever-spring system.

Normal springs exercise a restitution force proportional to their deformation x , $F_s = K_s x$. Centrifugal force acting on constant masses is proportional to the rotation radius, R , and to the square of the rotation speed, Ω : $F_c = K_c R \Omega^2$. Note that the spring deformation and the rotation radii of the spheres R are related in a way depending on the mechanical design of the gearing, $R = R(x)$. At equilibrium $F_s = F_c$, which leads to a nonlinear equation $x = (K_c/K_s)R(x)\Omega^2$. Therefore, these tachometers have a nonlinear velocity scale. In some models,

the nonlinearity is compensated for, to a certain extent, by using a nonlinear spring.

INDUCTIVE PULSES TACHOMETERS

The inductive pulses tachometer is a type of tachometer in which there is no mechanical contact between the moving shaft and the stationary sensor (Fig. 3). The output of the tachometer consists of a train of pulses, which can be processed either by analog or digital means. It consists of an iron-toothed wheel mounted in the shaft and rotating with it. Placed near it is a permanent magnet, around which a sensing coil is wound [Fig. 3(a)]. The magnet may be placed, as suggested by the figure, at a distance of about a millimeter from the outer face of the teeth. Alternatively, the magnet may be U shaped, with the wheel's teeth passing between the two poles.

As the wheel rotates, the teeth and gaps pass successively in front of the magnet, causing a periodic variation of the magnetic reluctance of the flux lines' path. Therefore, the induction flux through the coil wound around the magnet varies, thus causing periodic pulses of voltage to be induced at its terminals [Fig. 3(b)]. Both the amplitude and the frequency of the voltage impulses are proportional to the rotation speed and to the number of teeth in the wheel.

The rotation speed can then be obtained by means of any ordinary method of measuring the voltage peak value, time-average value, or rms value. However, this is not the most common way, as the pulse amplitudes depend on circumstantial factors, like the temperature or variations of the sensor position relative to the toothed wheel. Another drawback of this method is the difficulty of measuring very low speeds when the pulse amplitudes are not high enough to be measured accurately.

Alternatively, the speed can be obtained, and usually with better accuracy, by measuring the pulse frequency, f , which is equal to the shaft's number of rotations per second times the number of teeth n of the toothed wheel. Expressing the rotation speed N in rpm, the following is obtained:

$$f = nN/60$$

When using the frequency measurement method, generally the pulses are first processed through some sort of electronic comparing circuit, like the Schmitt trigger or equivalent, in order to produce a train of sharper impulses, whose amplitude is now independent of the speed. The frequency of the pulses is then measured, either analogically or digitally. The ways of implementing these measures will be described later. The difficulty of measuring very low speeds persists, however,

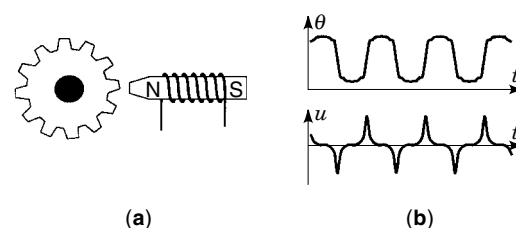

Figure 3. Inductive pulses tachometer. (a) Schematic constitution. (b) Flux and voltage at pick-up coil.

because the amplitude of the pulses from the pick-up coil may be too low to switch the electronic trigger. (This can be overcome if the field variations are sensed, not by means of the inductive process just described, but with a Hall effect sensor. The pulses produced by the Hall effect sensor have a constant amplitude, independent of speed, so only their frequency varies with the rotation velocity.)

To increase the sensitivity of the sensor at low speeds, wheels with more teeth are used. However, this procedure has time and space limitations. If there are too many teeth, the distance between them may become too small compared with the size of the polar piece. The polar piece would then face more than one tooth at a time, causing a space integration and averaging effect. The device would not be able to distinguish the teeth from the gaps and thus would become insensitive to the rotation. For this reason, the polar piece generally has a sharp tip, of a conical or other similar shape. A similar averaging effect occurs because of a time limitation. The pulses have nonzero duration. A wheel with a number of teeth, few enough to avoid the space integration but numerous enough to measure low speeds, will cause pulses of increasing frequency when the shaft speeds up. At high velocity, the pulses can become too rapid and start to overlap, and then the sensing circuit is no longer able to distinguish the too frequent pulses. For these reasons, a wheel with an appropriate number of teeth must be chosen for the range of rotation speeds to be measured.

The shape of the wheel's teeth is also designed according to the needs of the electronic circuitry to be used: Smoother teeth may cause an almost sinusoidal voltage to be induced, and teeth with sudden geometrical changes induce sharper pulses.

Some inductive pulse tachometers are provided with a second pick-up coil, generally placed in such a way as to induce pulses in quadrature with those of the first coil. The phases of both signals may be compared in some electronic circuitry to find if the second leads or lags behind the first one, thereby obtaining information about the direction of the rotation.

As there is no mechanical contact between moving and fixed parts, this kind of tachometer is suitable for use in low-torque mechanisms. If low inertia is also required, a plastic wheel is used, in which ferromagnetic pieces are regularly inserted in radial positions near the periphery. These pieces have the same effect of regularly modifying the magnetic reluctance of the flux path, thereby causing a periodic variation of the flux through the pick-up coil with the consequent induction of a voltage train of pulses. This kind of wheel is more expensive than an iron one, but, in addition to the lower inertia it offers, it has the advantage of producing sharper voltage pulses.

Inductive pulse tachometers are widely used because they need almost no maintenance, they need no power feeding circuits, and the sensor device is not expensive. Having no electric contact between moving and stationary parts, they produce no sparks and therefore can be used in potentially explosive environments. The magnet and pick-up coil are usually assembled in a sealed case, which is mounted near the wheel, without touching it and with no magnetic barrier between the wheel and the magnet.

HALL EFFECT PULSE TACHOMETERS

The Hall effect pulse tachometer is similar to the inductive pulse tachometer, except that the magnetic induction field

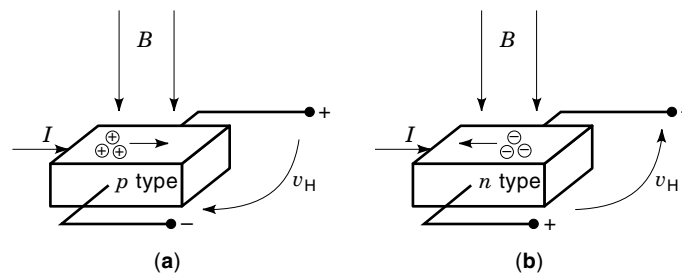

Figure 4. Hall effect sensor. (a) With *p*-type semiconductor material. (b) With *n*-type semiconductor material.

variations are sensed by means of a Hall effect sensor (Fig. 4) instead of a pick-up coil.

The Hall effect consists of the appearance of a voltage v_H through a material when an electric current I flows through it in the presence of an external magnetic induction field B . The electric carriers that constitute the current, because they are moving with a velocity v inside the field B , sense a Lorentz force. This is equivalent to an electric field $E = v \times B$, perpendicular to both the induction field and the current direction and that generates the external voltage that is felt.

The Hall effect can be better sensed in semiconductor than in conductor materials. The charge carriers will feel a force $F = qE$, which deflects their movement to one side of the material. If the material is *p* type [Fig. 4(a)], the carriers will be positive and the direction of velocity is the same as that of the current. Suppose that the B field is from the upper side; the positive traveling charges will be deflected to their left. The left side will then become positive with respect to the right side.

If the material is *n* type [Fig. 4(b)], the carriers will be negative; the direction of velocity is opposite to the current. The Lorentz electric field will be opposite to that of the previous case. As a consequence, the external voltage produced will also be reversed.

The voltage is directly proportional to the current I and to the field B . If a sensor based on the Hall effect device is fed with a constant current I , then the output voltage will be a measure of the induction B . Note that with inductive sensors, it is the time derivative dB/dt that is sensed, while with Hall sensors it is the field itself that is sensed, regardless of its rate of variation. Typical sensors are supplied with currents on the order of 10 mA and have an output sensitivity on the order of 10 V/T.

The construction of Hall effect pulse tachometers is similar to inductive pulse tachometers. Like them, a toothed ferromagnetic wheel rotates in front of a permanent magnet. Instead of the pick-up coil used in inductive pulse tachometers, a Hall sensor is placed between the permanent magnet and the rotating toothed wheel. The airgap variation of the magnetic flux path, caused by the succession of teeth and gaps of the wheel, causes a variation in the intensity of the B field over the magnet's pole. The output voltage of the sensor, being proportional to the B intensity, follows its variations. Another option is to use a wheel with magnetic poles in its periphery and avoid the stationary magnet. The Hall sensor will sense the magnetic field from the wheel's poles.

The output of the Hall effect tachometers is a train of voltage pulses with a frequency f that is equal to the shaft's speed (in rps), times the number of pole pairs n of the magnetized

wheel, or times the number n of teeth of the toothed wheel. Or, using the speed N in rpm,

$$f = nN/60$$

This frequency then is measured by one of the methods described later in this article. The pulses all have the same intensity regardless of the shaft's speed and, therefore, the device is sensitive to low as well as high speeds.

The sensor output is a measure of the rotation speed but gives no information about rotation direction. This is obtained with a second sensor placed in a position so that its signals are in quadrature with the first sensor's output. Electronic processing may distinguish which one is leading and which one is lagging, thus determining the direction of movement.

Hall effect tachometers have the same advantages of contactless sensing as inductive tachometers, but they have the additional advantage of sensing all speeds equally. However, they have the disadvantage of needing a power supply. When compared to optical-based tachometers, they have the advantage of being less sensitive to environmental conditions, like humidity, dust, or vibrations, and of having characteristics that vary less over time than the optical tachometers.

OPTICAL PULSE TACHOMETERS

Optical pulse tachometers (OPT) (Fig. 5), like the Hall effect tachometers, generate a train of constant amplitude pulses whose frequency is proportional to the rotating speed to be measured. The frequency of the pulses is measured either by analog or digital means, to be described later.

The pulses may be generated by two alternative ways: the incident light method or the reflected light method (also known as the transmittance and the reflectance methods).

The incident light type of optical tachometers uses the repetitive interception of a light beam to generate the pulses. A disk [Fig. 5(a)], which has at its periphery a sequence of transparent radial windows and opaque sectors, is mounted to the shaft and rotates with it. The entire disk may be made of transparent acrylic plastic, with black radial masks painted on it. Or the disk may be made of an opaque material, plastic or metallic, with slots cut in it; sometimes a toothed wheel is used. At one side of the disk, a light source emits a light beam parallel to the shaft. The light beam falls on a light sensing device. As the disk rotates, the transparent slots and the opaque zones alternatively cross the beam, alternatively transmitting and interrupting it, which causes a pulsing response of the light detector.

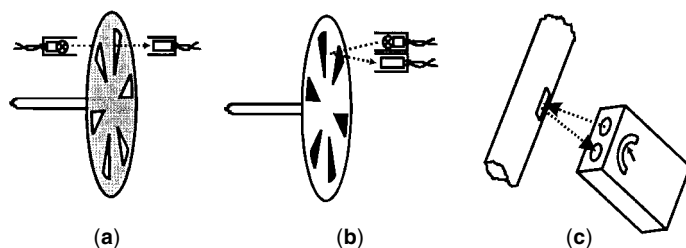

Figure 5. Optical pulse tachometers. (a) Incident light method. (b) Reflected light method. (c) Portable reflected light OPT.

The reflected light solution uses the light source and detector on the same side of the disk [Fig. 5(b)]. The disk now has no slots, but its face has alternate light-absorbent zones and light-reflecting ones. The rotation of the disk causes the light sensor to detect alternate pulses of reflected light. Marks alternatively painted black and white usually create the desired effect. If increased reflection is needed, strips of reflective tape may be glued over the disk. The surface of this tape is covered with small spherical lenses, and these lenses reflect the incident light back in the same direction, even if that direction is not perpendicular to the tape surface. The reflected beam solution may be implemented without the disk. The shaft itself may be painted with light-absorbent and -reflecting strips, or have reflecting tape strips fixed to it.

As in inductive and Hall effect tachometers, the frequency f of the optical tachometer's output is equal to the shaft's rotations per second times the number n of transparent slots in the disk (for the incident light method) or of reflecting marks (for the reflected light method). Using the rotation speed N in rpm,

$$f = nN/60$$

For use in mechanical settings where access is difficult or where inflammable atmospheres proscribe the presence of electric devices, the two light beams, one from the source and the other for the sensor, may be carried by optical fibers between the shaft proximity and the remote electronic setting.

The incident light method demands the disk to be mounted on the shaft and the light source and sensor to be installed carefully, in a fixed and correct position. Therefore, it requires more mechanical care than the reflected beam method, which may be used with an improvised mechanical setting, specially if the reflection is made on the shaft itself, without the use of the disk. However, the incident method device, once correctly installed, is more reliable because it provides steadier pulses than the reflected beam setting, which is more prone to errors due to vibration, misalignment, dust on the reflecting surfaces, and so on.

The ease of use of the reflected light method allows for the construction of stand-alone, battery-operated portable tachometers [Fig. 5(c)]. They include a light source, the reflected light sensor, the signal processor, the frequency meter, and a digital or analog display where the speed can be directly read, normally in rpm. Usually these tachometers are furnished with a set of reflecting tape strips. The operation consists only of pointing the instrument at the shaft, where the tape has been previously attached, pressing a switch to emit the light, and reading the desired rotating speed.

A number of construction solutions are available for these tachometers. Any light source may be used. Generally an electric bulb has been used, but an increasing number of models use light emitting diodes (LEDs). The sensor used to be a photoelectric cell, but photosensitive semiconductor devices are now most common.

Photoelectronic devices having both a photodiode and phototransistor are available on the market and are also used in the construction of tachometers. Some of these devices are made in a U shape, with the diode at one extreme and the transistor at the other, and are suitable for the construction of incident beam tachometers, the slotted wheel passing between the two extremities of the U. Other devices are made

with the diode and the transistor side by side and are appropriate for reflected beam tachometers. There are also reflected beam tachometers that use a laser beam, generally from a laser diode, when increased distance range is desired.

Like other pulse tachometers, optical tachometers measure the speed of rotation but not its direction. Another light source and sensor placed in quadrature is needed for phase detection and direction determination.

Optical tachometers have an advantage over the magnetic ones of easier installation and operation, but they have the disadvantages of being susceptible to environmental pollution, dust, and grease and of experiencing accelerated aging as the light source properties generally decay in time.

OTHER PULSE TACHOMETERS

Strain Gage Tachometers

A strain gage is a dc-fed Wheatstone bridge whose resistors vary their resistance when stretched or compressed. The resistors are fixed to a mechanical piece, which is to be deformed, and are mechanically installed in such a way that the deformation of the piece does not equally deform the four bridge arms. In so doing, a strain in the piece unbalances the bridge and causes a voltage output proportional to the deformation.

If the rotation of a shaft can be transformed into a periodic deformation of a stationary piece, then this deformation can be detected with a strain gage, causing an output signal that is synchronized with the rotation. The frequency of the signal is, therefore, equal to the rotation speed, but nothing can be said about its amplitude (this is preferably constant, but mechanical resonance may cause it to vary with the speed). This can be an appropriate way of sensing the rotation speed when the mechanical installation, by its own design characteristics, naturally causes a vibration or deformation of one of its stationary components. Then no further mechanical settings are necessary, except for the setting of a strain gage. If that mechanical deformation does not naturally occur, the method can still be implemented by introducing an extra piece and forcing it to suffer a deformation. The strain gage then is fixed to a cantilever-mounted beam, which is in contact with the periphery of an eccentric wheel or cam, driven by the shaft. The rotation of the eccentric wheel or cam causes a sinusoidal vibration of the beam, synchronized with the rotation.

The output characteristics of these tachometers depend on the sensitivity of the strain gage, and on the mechanical properties of the mechanical setting. The amplitude of the signal is not a measure of the speed, but its frequency is, and it should be read by one of the methods described later. However, transient mechanical vibrations or resonance with harmonics may introduce spurious frequencies and thus cause a false speed reading.

Variable Capacitance Tachometers

The usual design of variable capacitors consists of a set of fixed conductive parallel plates, among which another set of parallel plates can rotate. These are parallel to the fixed plates, and their rotation axle is perpendicular to both sets of plates. The capacitance of the capacitor is proportional to the

total juxtaposing area of fixed and movable plates, and this area depends on the angular position of the rotating plates.

If the movable plates are driven by a rotating shaft, then the capacitor will have a periodically changing capacitance, varying synchronously with the shaft rotation. This capacity variation may be sensed and translated into a measure of speed, in two different ways. One way is to feed the capacitor with a constant voltage U . Then its current i_c will be

$$i_c = \frac{dq}{dt} = \frac{d(CU)}{dt} = U \frac{dC}{dt} = U \frac{dC(\alpha)}{dt} \cdot \frac{d\alpha}{dt} = U \cdot \omega \cdot \frac{dC(\alpha)}{dt}$$

that is, proportional to the rotation speed ω , and will depend on the way the capacitance varies with the position.

If a smooth varying current is desired, the geometric design of the plates is such that a sinusoidal dependence $C(\alpha)$ is obtained, which causes a sinusoidal current to flow in the tachometer, with both amplitude and frequency proportional to the speed. The measure of any of these values indicates the desired speed.

For low speeds, these sinusoidal change derivatives may be too low to cause an easily measurable current. For this reason, the plates' design may include a smooth capacitance variation (for instance, a linear one, followed by a sudden change). The resulting current will be a smooth, low current during most of the period, followed by a sudden and sharp spike. The frequency of these pulses is proportional to the rotation speed and is fed to any frequency meter device to obtain the speed value. In general, the current must be first converted into a voltage, for measurement purposes.

An optional method of implementing a variable capacitance tachometer is to connect the capacitor to a Wien, Maxwell, or other ac capacitance measuring bridge. The bridge is fed with a ac voltage of a frequency higher than the rotation rhythm (more than 10 times the rotation pace) and is balanced for an intermediate capacitance value of the variable capacitor. The rotation of the shaft and the consequent variation of the sensor capacity periodically unbalance the bridge and cause it to output an ac voltage with the frequency of the power source and with an amplitude that periodically changes at the pace of the rotation. This is an amplitude modulation, with the feeding frequency acting as a carrier and the rotation speed acting as a modulator. This output signal is then demodulated to extract the modulator. The frequency of the modulator is then read by any of the usual processes, and that frequency is the desired speed value.

Switch Tachometers

The switch tachometer is a device that, when it is driven by the rotating shaft, alternatively makes and breaks electrical contacts in a circuit, causing current pulses, whose frequency is measured by any usual method. Generally the switch is connected to an RC circuit, and the current provoked is the periodic charge and discharge of the capacitor.

One type of switch tachometer has a pair of rotating contacts, driven by the shaft and connected to a capacitor pair of terminals. A dc voltage is fed through a resistor into a stationary pair of terminals. The rotating capacitor terminals contact the fixed ones, and the rotation causes their periodical inversion. This causes the capacitor to be alternately charged and discharged through the resistor, with the resulting pulsed current.

Another type of switch tachometer uses a fixed circuit, with commuting switches driven by the shaft. A common way is to use reed switches. The reed can oscillate between two positions, each one making contact with a different circuit topology. The reed can be mechanically driven by a cam or yoke. A popular design is to make the reed magnetically actuated by a magnet fixed to the shaft. Being very flexible, the reed is attracted by the magnet and then released, which makes it alternatively touch two contacts.

The switch tachometer is referred to later in this article, in the section on frequency measurement.

STROBOSCOPES

The stroboscopic method of speed measurement is based on the inertia of the human eye. Therefore, it demands the presence of a human operator in the measurement loop. If a rotating or vibrating object is illuminated by a pulsing light whose flashing rhythm coincides with the rotation or vibration speed, the object will be illuminated whenever it is in the same position. Hence, it will always be seen in that position. The human eye, being incapable of distinguishing successive flashes if they are too rapid, will give the sensation of seeing an object standing still.

Stroboscope tachometers are made of a flashing lamp, a device to control its rhythm, and a frequency meter. Most stroboscopes have all the components integrated in the same portable box. The operation consists of pointing the light at the rotating shaft, regulating the flash frequency until the shaft appears stationary, and reading the frequency. For easier detection of the apparent immobility, the shaft must have some distinguishable feature on its outer surface. Normally, a white mark is painted or a reflective tape is fixed to the shaft. Old stroboscopes used a slotted rotating wheel to mask periodically the vision of the shaft or to interrupt periodically an illuminating light beam. Modern stroboscopes use a gas-filled flash lamp, which has a grid between its cathode and anode.

A high voltage, from a capacitor that is periodically charged, is applied between the cathode and the anode. Voltage pulses from a pulse generator are applied to the grid, each pulse permitting an electrical discharge from the capacitor through the bulb gas, with the resulting emission of an intense and short (about $10 \mu\text{s}$) strobe of light. Before the next voltage pulse is applied to the grid, the capacitor is again charged.

The frequency of the triggering pulses may be read directly on a dial mounted on the adjustment knob of the flashing rhythm, or the stroboscope may include an extra frequency meter, either analog or digital. Generally this frequency may be directly read in impulses per minute, to coincide with the usual way of expression rotation speeds.

Sometimes it is difficult to determine what the speed is, because the shaft may look like it is standing still for different flash frequencies. This may happen when different harmonics of the rotation rhythm are used as flash frequencies (in this case, the image of the mark in the shaft may be repeated in more than one position). Then a frequency f_1 for apparent immobilization must be found, and then the next and closest stationing frequency f_2 must be located. These two frequencies, because they are as close as possible, are two consecutive

harmonics of the rotation rhythm N ; that is, $f_1 = KN$ and $f_2 = (k + 1)N$; therefore, the speed is $N = f_2 - f_1$ (assuming all the quantities are in the same units, that is, minute^{-1} or second^{-1}).

Inversely, if the flashing rate is a subharmonic of the rotation speed, $N = Kf_1$, then the same frozen image aspect will occur, with the mark visible in only one position. Then the frequency of flashes must be decreased until the next frozen image appears, which happens at frequency f_2 , such as $N = (K - 1)f_2$. Then $1/N = 1/f_2 - 1/f_1$ or $N = f_1 f_2 / (f_1 - f_2)$ is obtained.

Stroboscopes are an easy and straightforward method of measuring speed that can be used without any mechanical setting and applied to any periodically moving mechanism. However, they have the disadvantage of not furnishing an automated output. The range, precision, and light intensity of these devices vary from maker to maker. Ranges from 5 Hz (300 rpm) to 300 Hz (18,000 rpm) or even up to 417 Hz (25,000 rpm) are available, with accuracy on the order of 1%. The light intensity of each flash may be on the order of 1500 lx.

FREQUENCY MEASUREMENT

Analog Frequency Measurement

There are several methods for analog frequency measurement, but we shall limit the discussion to those most often used in tachometers. These are the conversion of the frequency into a proportional dc voltage, which is measured with a common dc voltmeter, or into a dc current, which is measured with a dc ammeter.

Frequency Voltage Conversion. The frequency voltage converter (Fig. 6) is based on the fact that the average value V of a train of pulses of constant amplitude U , constant duration T_0 , and period T [Fig. 6(a)] is $V = UT_0/T$. With these assumptions, $UT_0 = A$ is a constant (the constant area of each pulse), and $1/T = f$ is the frequency to be measured. Hence, $V = Af$ results. Each constant amplitude, constant duration pulse is produced by a monostable circuit, which must be accurate and stable. Its pulse duration must, of course, be

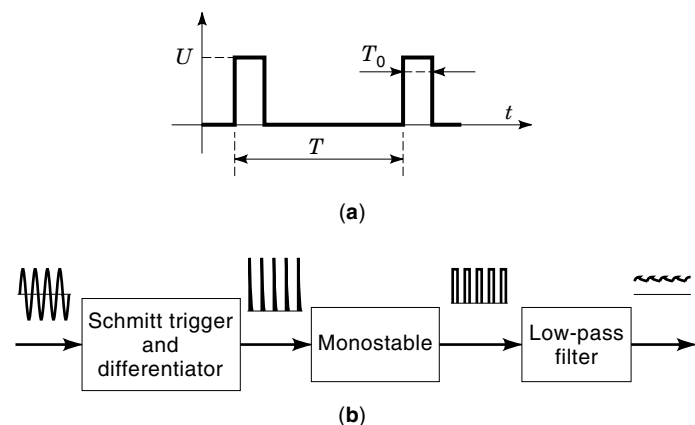

Figure 6. Frequency measurement by frequency-voltage conversion. (a) Time diagram of a train of constant-area voltage pulses. (b) Block diagram of a frequency-voltage converter.

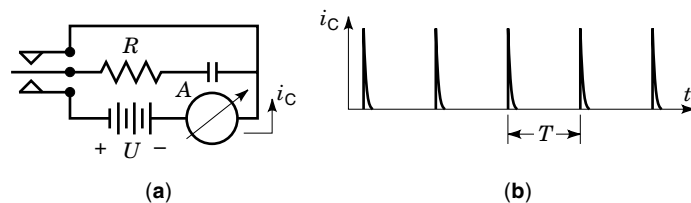

Figure 7. Frequency measurement by frequency-current conversion. (a) Circuit. The reed actuator is not shown. (b) Time diagram of the charging current of the capacitor.

shorter than the minimum period corresponding to the maximum frequency to be measured.

The input signal is fed to a shaping circuit [Fig. 6(b)], generally a Schmitt trigger and a differentiator, in order to get new short and sharp pulses synchronized with the incoming ones. The shaped pulses attack the monostable circuit, each pulse causing the output of a constant-area pulse. The train of these constant-area pulses is fed to an averaging circuit (an RC circuit, or an integrating amplifier with discharging resistor), functioning as a low-pass filter of time constant τ . Its output will be the average value V , with a ripple $V_R = V/(f\tau)$.

For the propose of visual reading of the frequency with a voltmeter, there is no need for a high-quality filter, as the mechanical inertia of the meter itself has an averaging effect. For use in an automated measurement chain, a tradeoff must be made between the presence of output ripple and response time of the filter.

Frequency-Current Conversion. Another analog method of frequency measurement, similar to the first, is to convert the frequency into an average value of a capacitor charging current (Fig. 7). The alternative input signal whose frequency is to be measured, by any way, controls a switch that can be commuted between two positions [Fig. 7(a)]. The positive part of the signal causes the switch to apply a dc voltage U to an RC series circuit. The negative part of the signal commutes the switch to a position where it short circuits the same RC circuit. The time constant $\tau = RC$ remains the same during the charge and the discharge, and the circuit is dimensioned to be $\tau \ll T/2$, where T is the period of the signal.

For fast signals, the switch must be electronic. For signals up to a few hundred hertz, reed relays can be used. This is generally the frequency range of the signals involved in rotation speed measurements; therefore, the speed can be measured by using some kind of generating device driven by the shaft to produce an alternating voltage and using this voltage to drive an electromechanical reed relay. However, it is much simpler to actuate mechanically the reed of the switch with a cam geared with the shaft, or magnetically actuate the reed by a magnet that is fixed to the shaft and rotates with it. Thus, the frequency of the rotation can be measured without the need of generating an electric signal just for the purpose of actuating a relay.

If $\tau \ll T/2$, one can assume that the capacitor is totally discharged when the switch causes the voltage U to be applied and that the capacitor totally charges before it is shorted again. In this assumption, a relative error $e = e^{-T/2\tau}$ is neglected compared with 1, for which it must be $T > 10\tau$, if the error e is to be $e < 0.5\%$, or $T > 14\tau$, if it is to be $e <$

0.1%. Therefore, the charging current i_C is a quick pulse that ends before the next commutation [Fig. 7(b)], and it carries the total final charge $Q = CU$.

The charge being the time integral of the current, and there being no more charging current for the rest of the interval T , we obtain

$$\int_T i_C dt = Q = CU$$

that is to say, the area of the pulse is constant and is equal to CU . Therefore, the average value I_{av} of the current i_C during a period is proportional to the frequency, as it is

$$I_{av} = \frac{1}{T} \int_T i_C dt = \frac{CU}{T} = CUf$$

For control purposes, this current must be converted into a voltage and averaged, to obtain a dc voltage signal. For reading purposes, however, it is enough to read the charging current with an averaging ammeter, such as the moving coil type.

Digital Frequency Measurement

Digital frequency measurement (Fig. 8) consists of counting the number of the signal periods that fit in a certain time interval (for instance, 1 s). For this, the input signal of frequency f_s is fed into a conditioning and shaping circuit [Fig. 8(a)], which generates a train of pulses synchronized with that signal, and with appropriate amplitude for the next electronic blocks. This first circuit generally includes an attenuator, an amplifier, a trigger, and a differentiator.

The synchronized train of pulses is fed into a digital counter, through an electronic gate that is generally an AND gate. The gate is kept opened for a unit period time T_c , because, in its control input, a signal from an internal clock is applied. An edge-triggered flip-flop maintains the gate-opening control signal on for an entire clock period T_c [Fig. 8(d)]. In this way, the digital counter counts the number of input signal periods during a unit time (that is, measures the frequency).

Generally, the clock consists of a high-accuracy crystal oscillator of 1 MHz (or of 100 kHz) and a series of six (or five) frequency dividers [Fig. 8(c)]. Each one receives a signal from the previous divider (or from the oscillator, if it is the first divider), divides the signal frequency by 10, and passes the resulting signal to the next divider. In this way, clock signals of 1 MHz (or 100 kHz) down to 1 Hz are available. The digital counting error is of one unit, and the counting is $f_s T_c$. Therefore, the relative error is $\epsilon = 1/(f_s T_c)$. For increased accuracy, the measurement should be made by counting as many input signal periods as possible, which means counting during the longest internal clock period possible.

If the input signals come from a pulse tachometer that generates only a few pulses per rotation, then the input frequency may be low and the machine may be turning very slowly. Therefore, the speed measurement may demand too much time for use in control purposes. As it is the number of turns per time interval that is counted, it is the average speed in that time interval that is obtained. In the case of slow motion and long counting time intervals, this average speed may differ significantly from the usually desired instantaneous

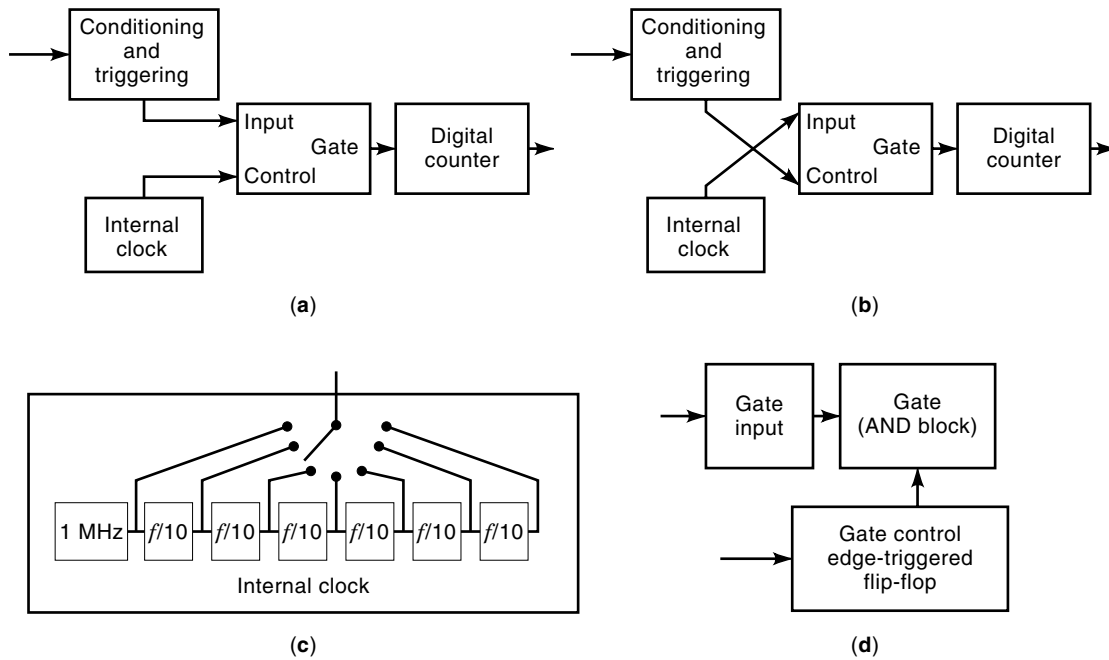

Figure 8. Digital frequency measurement. (a) Block diagram of the circuit for frequency measurement. (b) Block diagram of the circuit for period measurement. (c) Block diagram of the clock. (d) Block diagram of the gate.

speed. In that case, instead of measuring the number of turns per unit time, the inverse measurement is more appropriate. The duration of a single rotation is measured. This is done by reversing the roles of the input-synchronized and the clock pulses [Fig. 8(b)]: The input-synchronized pulse is applied to the edge-triggered flip-flop, keeping the gate opened during an input period $T_s = 1/f_s$, and the counter counts the number of clock ticks that fit in an input period. The result is the time between input signal pulses, or signal period, and the frequency is its inverse.

Using a clock of frequency $f_c = 1/T_c$, the count will now be $f_c T_s$, and the error of one unit represents a relative error $\epsilon = 1/(f_c T_s) = f_s T_c$ (the inverse of the former case). Good accuracy requires that a quick clock signal be used, and so the measurement may be done in a short time. This is appropriate for the measurement of slow signals, such as those from a tachometer installed in a slow machine.

Inverting the time measured, an (almost) instantaneous speed of rotation is obtainable. This is sometimes called the division by time technique for speed measurement. Because the result of the operation is a digital number, the output circuitry may include a processor to execute the operations needed to convert the count into the appropriate speed units, usually rpm, if the number is to be displayed on the tachometer.

GYROMETERS

Gyrometers are devices for measuring the velocity of rotation of a vehicle with respect to an inertial frame. There are several types of gyrometers, such as mechanical spinning gyroscopes (rate gyros), mechanical vibrating gyroscopes, gas-jet nongyro rate transducers, and optical interferometers gyros (optical gyros).

Spinning Rate Gyros

Mechanical rate gyros are single degree of freedom gyroscopes. A gyroscope is essentially a spinning wheel (Fig. 9) whose spin axis coincides with its principal geometric axis of

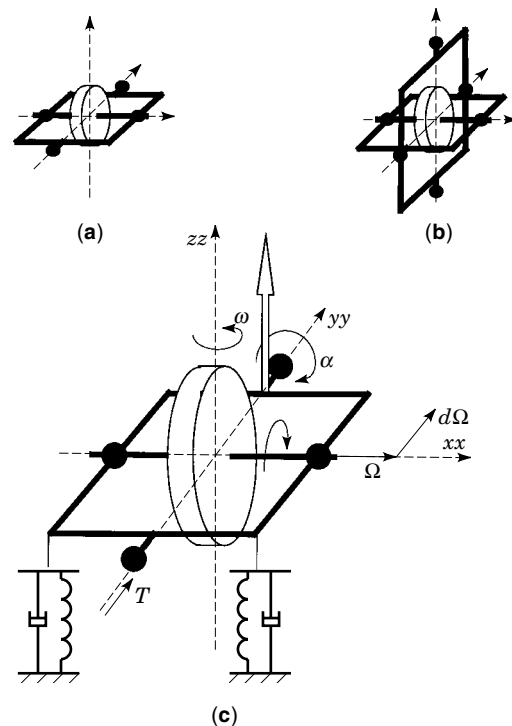

Figure 9. Spinning wheel gyroscope. (a) Single degree of freedom. (b) Double degree of freedom gyroscope. (c) Rate gyro.

rotation. The wheel's axle is supported by bearings located in a frame that surrounds the wheel. The supporting frame itself has an axle, orthogonal to the wheel's axle. The frame can also be rotated about its axle, which is supported by a second pair of bearings. This second pair of bearings can be fixed to the device case. Therefore, the frame is free to rotate about its axle, permitting the wheel's spinning axis to have a rotation movement on a plane perpendicular to the frame's axle. The device just described is called a single degree of freedom gyroscope [Fig. 9(a)].

Alternatively, the bearings supporting the frame may be fixed to a second outer frame. This second frame has a (third) axle of its own, perpendicular to the axes of both the wheel and first frame, and now this third axle is supported by a third pair of bearings fixed in the mechanism case. With this doubly articulated suspension, the wheel's spinning axis can rotate in two perpendicular planes and can thus assume any direction in space. This is the double degree of freedom gyroscope [Fig. 9(b)]. The supporting frames are called gimbals. They are also called Cardan suspensions, after the sixteenth-century mathematician and physician Gerolamo Cardano (1501–1576), discoverer of the solution of the third-degree equation and inventor of this suspension.

If the wheel's angular velocity is Ω , then its angular momentum equals $\mathbf{H} = \Theta \cdot \Omega$, where Θ is the momentum of inertia of the wheel. Both \mathbf{H} and Ω are axial vectors, and Θ is a tensor. However, if the component of the rotational velocity of the wheel around its axis is much greater than any other components, then \mathbf{H} may be considered parallel to Ω , and Θ may be considered a scalar constant. This requires that the wheel be spun at high speed.

Newton's second law applied to rotating bodies states that $\mathbf{T} = d\mathbf{H}/dt$, where \mathbf{T} is the torque acting on the body and $d\mathbf{H}/dt$ is the time derivative of the angular momentum computed in an inertial reference frame. It follows from this law is that if no torque is applied to the wheel (i.e., $\mathbf{T} = 0$), then its angular momentum will be kept constant. The wheel's spin will maintain its speed and its axis will maintain its direction with reference to the distant galaxies.

This principle is the basis for the use of a double degree of freedom gyroscope as an inertial navigation device. The case of this apparatus is fixed to a moving vehicle. The vehicle's rotational motion causes the axis of the gimbals to rotate with it, with respect to an outer, inertial reference frame. Assuming that the bearings are frictionless, the movement of the gimbals transmits no torque to the spinning wheel. Therefore, in the interior of the revolving gimbals, the spinning wheel maintains the direction of its axis of rotation. The angles between the axis of the wheel and the outer case indicate the attitude (angular orientation) of the vehicle. In practice, the friction in the bearings and other causes impart a small torque to the wheel, and, therefore its axle will have slow motions, which are the major source of error in this type of mechanism. Special care is taken in their construction to reduce and compensate for these torques. However, the spatial attitude normally is measured with rate-integrating gyros (to be described later) because less error is obtained using three rate-integrating gyros (one for each spatial axis).

For measuring the turning speed (turning rate) of a vehicle, single degree of freedom gyros can be used in a configuration that is called rate gyro [Fig. 9(c)]. This device can sense a vehicle's rotation speed around one axis. To sense the rotation

around the three space directions, three orthogonal rate gyros are needed.

A rate gyro is a spring-restrained single degree of freedom gyro. The gyro's single frame can execute small rotations around its own axle, but this movement is restrained by restitution springs, which impart a restitution torque proportional to the inclination of the frame about its axle. Generally, this movement is also slowed down by mechanical or electric dampers connected to the frame. The entire apparatus is fixed to its case and to the vehicle. If the vehicle turns in a plane parallel to the frame plane, the whole set is forced to turn with it.

Consider a moving referential xyz fixed to the gyroscope, with the xx axis aligned with the wheel's spinning axle, and the $x0y$ plane coincident with the gimbal. Then the frame can oscillate about the yy axis, and the device will be able to detect the vehicle's motion about the zz axis.

In this moving referential, the vector \mathbf{H} can be expressed as $\mathbf{H} = H \cdot \hat{u}_x$, where H is its magnitude and \hat{u}_x is the unitary vector along the xx axis. Then Newton's law can be written as

$$\mathbf{T} = \frac{d\mathbf{H}}{dt} = \frac{dH}{dt} \cdot \hat{u}_x + H \cdot \frac{d\hat{u}_x}{dt} = \Theta \left(\frac{d\Omega}{dt} \cdot \hat{u}_x + \Omega \cdot \frac{d\hat{u}_x}{dt} \right)$$

The first parcel in the right-hand side of the equation represents a variation of the magnitude of the wheel's spinning speed Ω caused by any possible accelerating or braking component of the torque along the xx axis. If the torque is perpendicular to the spinning axle, however, then the speed will be kept constant in magnitude, $d\Omega/dt = 0$, but the spinning axis will deflect in the direction of the torque. It is equivalent to saying that the direction ϕ of its axis \hat{u}_x will be rotated toward the yy axis with angular speed $\omega = d\phi/dt$, resulting in

$$\frac{d\hat{u}_x}{dt} = \frac{d\phi}{dt} \hat{u}_y = \omega (\hat{u}_z \times \hat{u}_x)$$

Substituting this relation in the former expressions and using the axial vector $\boldsymbol{\omega} = \omega \cdot \hat{u}_z$ to represent the angular turning speed of the entire frame (and of the vehicle) around the zz axis, it follows from Newton's law that $\mathbf{T} = \boldsymbol{\omega} \times \mathbf{H}$.

The final conclusion is that, by keeping the wheel's spinning speed constant, the angular motion of the vehicle about the zz axis (called the rate input axis) causes the frame to move about the yy axis (called the output axis), under the influence of a torque proportional to the turning rate. The frame inclination about the output axis reaches an angular value α at which the restitution torque from the restraining springs, $T_r = K\alpha$, balances the gyroscopic torque, which is $T_g = H\omega$ (assuming that the turning rate and the angular momentum are kept perpendicular). A pointer fixed to the frame shows, on a scale fixed to the case, this angle α , which measures the turning rate ω about the input axis. At equilibrium $\alpha = S\omega$, where $S = H/K$, the device static sensitivity has the dimensions of time and is measured in seconds.

Note that these results are true only if the angle α is kept small enough to allow to consider approximately $\sin(\pi/2 - \alpha) = 1$. As the gyroscopic torque results from a vectorial product, its magnitude is indeed $T_g = H\omega \sin(\pi/2 - \alpha)$, which only can be taken as $T_g = H\omega$ for a small inclination α . Using the approximation $\sin(\pi/2 - \alpha) = 1$ introduces a relative error ϵ ,

which is $\epsilon < 1\%$ if $\alpha < 8^\circ$, and $\epsilon < 1.5\%$ if $\alpha < 10^\circ$ in the expressions deduced.

Note also that if the gyroscope's frame is allowed to rotate unrestrained until the angle α reaches 90° , a singular situation is reached: The input axis and the spinning axis coincide at that point, the angle between them becomes null, and, therefore, the torque becomes $\mathbf{T} = \boldsymbol{\omega} \times \mathbf{H} = 0$. Without torque, this situation will not be further modified, and all the orientation information will be lost. This situation is referred to as "the gimbals lock."

Instead of a pointer, a potentiometric position sensor may give an electric signal that measures the frame's deflection. Alternatively, the restitution springs may be replaced by restitution electric motors, usually called torquers, controlled by a feedback system that maintains the frame in its original position. These motors must generate a torque with the same magnitude as the gyroscopic torque, for which they require a proportional feeding current. Therefore, this current is the measure of the turning rate. The use of these motors has the advantage of measuring the torque without requiring a real displacement α , thus allowing the orthogonality between the input and the spinning axis to be maintained. Otherwise, the restraining springs require the displacement to generate the torque.

The operation of the device intrinsically involves a rotation movement of the frame about the output axis. Therefore, its dynamic motion is determined by the equilibrium of the acting gyroscope torque $T_g = H\omega$, the resisting spring torque $T_r = K\alpha$, the friction torque opposing the movement $T_f = D(d\alpha/dt)$, and the inertia torque $T_i = \Theta_y(d^2\alpha/dt^2)$, where D is the dumping coefficient and Θ_y is the moment of inertia of the whole set about the yy (output) axis. This leads to a second-order differential equation, the solution of which shows the possible existence of oscillations with a natural frequency $\omega_{\alpha 0} = (K/\Theta_y)^{1/2}$ and a dumping degree $\beta = D/(2(K\Theta_y)^{1/2})$. As is customary in moving measurement apparatus, the dumping degree is usually chosen to be $\beta = 0.707$, and D is computed to achieve this goal.

The preceding expressions show that a high sensitivity $S = H/K$ is obtained using a spinning wheel of high angular momentum, which must be achieved by spinning it at as a high speed as possible. Reducing the spring constant K will also increase the sensitivity, but this will also reduce the resonance frequency $\omega_{\alpha 0} = (K/\Theta_y)^{1/2}$.

To obtain high angular momentum, the wheel must have a high momentum of inertia and a high spinning speed, but these goals must be traded off against excessive device mass and size, as well as the spinning motor power required. The momentum of inertia may be increased by the use of wheels provided with a thick rim around them. The wheel may be driven by a variety of motors. It can be connected to a turbine moved by a jet of compressed air or by combustion exhaust gases. In short-life gyros used in rockets, the hot gas jet may be produced by a pyrotechnic charge. The most common solution is an electric drive, ac as well dc motors being used. In some devices, the spinning wheel is the rotor of an induction motor.

The typical spinning speed for the inertia wheel is on the order of tens of thousands rpm. Rate gyros have typical rate resolution of 0.01° per second and range up to 2000° per second. Their natural frequency is on the order of some units to a few tens of hertz.

Rate-Integrating Gyros. The measurement of a vehicle's attitude can be made with a pair of double degree of freedom gyroscopes. However, spurious torques cause unwanted movements of precession and mutation of these gyroscopes, diminishing their accuracy. Therefore, it is usual to compute the attitude as a time integral of the turning rates about the three space axes.

This integration can be made electronically and is generally so done when the sensors are part of a wider measurement or control system. Sometimes, especially if only a visual indication is needed, a rate-integrating gyro is used. This rate-integrating gyro has the same structure as the rate gyro just described, except for the fact that it has no restraining springs. Instead, the dumping coefficient D of the frame rotation is increased. This increased dumping can be achieved electrically or mechanically (for instance, by making the frame rotation drive a paddle wheel rotating inside a viscous liquid).

Therefore, the acting torque developed has the same expression as in the former gyro, $T_g = H\omega$. But in the equation of its dynamic motion, $T_g = T_r + T_f + T_i$, the restraining-spring torque T_r is null, leaving $H\omega = D(d\alpha/dt) + \Theta_y(d^2\alpha/dt^2)$. In equilibrium, the acceleration $d^2\alpha/dt^2$ will be null, leaving the frame rotating at the speed $d\alpha/dt = (H/D)\omega$, proportional to the vehicle's turning rate. Except for initial values that can be zeroed at the beginning of the operation, the integrals of both rotating speeds will also be proportional. Therefore, the vehicle's attitude angle ϕ and the frame position angle α will keep the relation $\alpha = (H/D)\phi$. The constant (H/D) is the sensitivity of the rate-integrating gyro and increases with the inertia wheel's speed. The differential equation is of the first order, which means the device has no oscillations but has a time constant $\tau = \Theta_y/D$.

Vibration Gyros

These devices make use of pendulums, instead of rotating wheels, to conserve momentum. A pendulum without a transversal torque applied will conserve its plane of oscillation in a inertial reference frame—in the same way that a spinning wheel conserves the direction of its axis. If the plane of oscillation is forced to rotate about an axis coincident with the pendulum's equilibrium position, then a torque will result, which tends to bend the pendulum. Instead of free pendulums, vibrating cantilever beams are used. The rotation rate of the vibration plane causes bending of the beams. This generates a strain that can be measured and that is proportional to the turning rate and to the frequency of vibration.

This principle allows for the construction of very small and accurate vibrating gyroscopes. The cantilever beams used are bars a few centimeters or millimeters long. They have a piezoelectric material incorporated that, being fed by an electric power source, drives the vibration at a frequency on the order of tens of kilohertz. Other piezoelectric pieces are fixed to the other faces of the vibrating bar and act as strain gages to sense the transversal strain. Generally, these sensors are fixed to opposite faces of the beam and are connected in a bridge configuration for higher sensitivity to changes of strain and noise cancellation.

This technology allows for the production of very small and lightweight devices, with size on the order of $2 \text{ cm} \times 3 \text{ cm} \times 6 \text{ cm}$ and weight about 40 g, including the necessary circuitry.

Their maximum input is about 90 degrees per second, their output is on the order of 20 mV/degree · s⁻¹, and their linearity is on the order of 0.1% of the range.

Gas-Jet Rate Transducers

Gas-jet nongyro rate transducers are inertial devices, but instead of conserving the angular momentum as the gyros and vibrating beams do, they are based on the conservation of linear momentum: A particle thrown in free space will travel along a straight line. The particles they use are the molecules of a stream of gas, usually helium, which is blown through the top of a cylindrical metallic box by a nozzle that forms a laminar flow beam. The gas beam travels in a straight line to the opposite side of the cylinder, where it reaches an exhaust hole to which it is pumped and recirculated. The nozzle format and the pumping are crucial, as the travel time of the gas along the cylinder must be kept constant. Generally, the pump is a vibrating circular crystal driven by an external oscillator.

If the box is made to rotate about an axis perpendicular to the gas beam, the beam will no longer reach the same point of the opposite face. The gas will travel in a straight line with reference to an inertial frame but, as it travels, the target point will move in the sense of the angular rotation. Seen in the box referential, the gas beam seems to have been deflected in the lagging direction of the rotation. As the traveling velocity of the gas is kept constant, the lag of the beam is proportional to the speed of the rotation.

To sense the lagging of the beam, two equal and parallel wires are positioned, one at each side of the beam and equidistant to the equilibrium position of the beam. Both wires have equal currents, so they reach the same temperature. They are connected in a bridge configuration, so their voltages balance each other.

When the set is rotating, the gas blows preferably over the lagging wire than over the leading wire. Therefore, the lagging wire cools and its resistance decreases, while the leading wire heats up and its resistance increases. This unbalances the bridge and causes a voltage output that is a linear measure of the magnitude and direction of the turning rate.

These devices have no moving parts, so they are very rugged and have long operating lives. They are closed systems, having only electric contact with the outside world, and thus are adequate for operating in unfriendly environments, such as under water, in outer space, or in aggressive atmospheres. A variety of models and sizes are available, and small devices can be found. The cylinder can be a few centimeters in diameter, though its length is generally a little longer, and it can be as light as 60 g. A typical range is 10° to 5000° per second, with an output of about 0.01 mV/degrees · s⁻¹ to 0.5 mV/degree · s⁻¹, and linearity of 1% full scale.

Optical Gyros

The principle of operation of optical gyros is the intrinsic modification of some characteristics of light due to the motion of the medium in which the light travels (Sagnac effect). This modification is sensed through the observation of light interference patterns.

When a surface is illuminated by monochromatic light coming from a small light source, the distance the light must travel from the source to each point on the surface is point

dependent. Therefore, the light reaches different points with different delays. Because the light is a sinusoidal oscillation of the electromagnetic field, the different delays cause the sinusoids to have different phases at the different surface points. If there is a second light source of the same wavelength illuminating the same surface, the second light beam will also reach different surface points with different phases. At the points on the surface where the two impinging beams are in phase, the beams interfere constructively, their fields are added, and the illumination of those points is increased. At the points where the two beams are in opposition, the beams interfere destructively, their fields are subtracted, and the illumination of those points decreases. If both the frequency and phase difference of the two beam sources are constant, the zones of constructive and destructive interference stand still, and a stationary pattern of dark and bright fringes becomes visible.

If the phase of one of the sources is shifted relative to the other, the correspondent wave will strike each surface point with the same phase shift. Therefore (assuming that the shift was not an integer of 2π), at the points where the two light beams were in phase, they will cease so being and no longer interfere constructively. However, the two beams will meet together in phase at new points on the surface. As a consequence, the interference fringes move about the illuminated surface, their spatial shift being proportional to the phase shift that occurred at the light source. The measurement of these interference fringes' shift is at the heart of optical gyros, because the shift is due to the motion of the optical devices relative to an inertial reference frame, as shown next.

A beam of light will take a time $t = L/c$ to travel along a path of length L , where c is the speed of light in the propagation medium. If the medium itself is moving with velocity v in the same direction as the light is, then the end of the path will have traveled the displacement $dL = vt = Lv/c$ by the time the light reaches it. This is an extra length that the light must travel, and therefore the total length traveled by the light is $L_1 = L(1 + v/c)$. In an analogous way, if the light travels in a direction opposite to the movement of the medium, the total length is now $L_2 = L(1 - v/c)$. Two beams traveling in opposite direction will go through different distances, the difference being $\Delta L = L_1 - L_2 = 2Lv/c$. If the path is circular with radius r , then $L = 2\pi r$. And if the path is rotating about its center, in a fixed plane, with angular speed Ω , then $v = \Omega r$, and therefore $\Delta L = 4\pi r^2\Omega/c = 4A\Omega/c$, where A is the area enclosed by the path. Although the preceding equation was derived for a circular path, it can be shown that the final result holds for any planar closed path. The difference ΔL can now be used in different ways to measure the motion of a body by exploring interference phenomena, originating the laser ring gyros (LRGs) and the fiber-optic gyros (FOGs).

Laser Ring Gyros. Laser ring gyros are usually used as attitude sensors. In the case of motion on a single plane, they measure the angle between an initial direction that is taken as a reference and the current direction of the main body axis of the moving vehicle or platform. At a particular instant, this angle is proportional to the number of wandering interference fringes that will have already passed in front of an optical detector, as described next.

In laser gyros, the light source is a gas laser tube, the most usual choice being an He–Ne gas laser. The tube emits in both directions and is inserted in a closed optical path. The path is a closed polygon, usually a triangle, made of ceramic glass. Mirrors at the corners of the triangle reflect the light around the corners. One of the mirrors is a partially transmitting mirror. The light coming from one direction of the path goes partially through this mirror directly into an optical interference sensor. Light coming from the other direction crosses partially the mirror, is reflected back by a prism, and impinges on the same optical sensor.

The whole optical path works as a resonant cavity, tuned in such a way that two laser beams are established, both having a wavelength λ that is an integer submultiple of the length L of the path. The two beams travel in opposite directions.

When the whole path rotates, the beams travel different distances and therefore each beam is tuned to a different wavelength. The difference of the two wavelengths is proportional to the difference in the distance traveled: $\Delta\lambda/\lambda = \Delta L/L = 4A\Omega/(cL)$. Because $\lambda = cf$, it follows from the preceding expressions that $\Delta f/f = -\Delta\lambda/\lambda$, where f is the frequency of the light. Therefore, the rotation of the laser ring makes the two beams acquire a frequency shift $\Delta f = -4A\Omega/(\lambda L)$.

This frequency shift is very small, as the preceding equations show: In devices about 10 cm across, movements of one rotation per second result in $\Delta f/f \sim 10^{-9}$. With such a small frequency difference, for practical purposes the two beams may be viewed as having the same frequency but a nonconstant phase difference. Thus, they behave as if one of them is lagging the other by an uniformly growing phase difference $\Delta\phi = 2\pi\Delta f t$. The speed at which the phase lag increases is $2\pi\Delta f$.

The interference of the two beams at the receiving surface will show a fringe pattern that will be shifted by a distance proportional to the phase lag. Therefore, as the phase lag uniformly increases, the pattern will wander over the receiving surface. The wandering velocity of the fringes over the surface is proportional to the rate of the phase difference. Over a particular point, a new fringe passes each time the phase difference $\Delta\phi$ increases by 2π . Therefore, the fringe rate, expressed in the number of fringes over a point per unit time n_f/s , equals Δf . The final result is that the wandering rate of the fringes is proportional to the rotation speed of the optical laser gyro with respect to an inertial frame; that is,

$$\frac{n_f}{s} = \frac{4A}{\lambda L} \Omega$$

The interference sensing device consists of an optical sensor, typically a photodiode, that senses the bright fringes and generates an electric pulse for each fringe that passes over it. The wandering rate of the fringes can be measured by counting the number of pulses per unit time, and this provides a measure of the angular speed of rotation. However, the most usual utilization of laser ring gyros is for measuring angular position, not angular speed. Since the angular position α is the time integral of the rotation speed, α can be determined from the number N of fringes that have passed over the diode since the beginning of operation. Thus, by simply maintaining a permanent account of the fringes that have passed, the angular position is measured. A double photodiode is needed,

with both detectors mounted in quadrature, to sense the wandering direction of the fringes and therefore properly increment or decrement the counter.

From the preceding equations, it can be seen that $\alpha = N(L\lambda/4A)$. The factor $S = L\lambda/4A$ is called the nominal scale factor of the ring laser gyro. For an He–Ne laser ($\lambda=633$ nm) and a triangular ring of 10 cm side length, $S = 1.1 \times 10^{-5}$ rad/pulse, or $S = 2.3(\text{arcsec})/\text{pulse}$.

Laser ring gyros are very sensitive devices; they are small and light. They have a fast warm-up and rapid response, and they are insensitive to linear motion. They also are free from multiaxis cross-coupling errors. Their price is decreasing and is competitive with the price of other types of gyros. Therefore, laser ring gyros tend to replace other inertial attitude sensors in air- and spacecrafts.

Rate Fiber-Optic Gyros. Fiber-optic gyros are commonly used as rate gyros; the phase difference between two light beams provides a measurement of the turning angular velocity of a platform (this the principle of the interference fiber-optic gyros, or IFOGs). However, the phase measurement cannot be simply executed by the procedure of counting interference fringes, as will be explained next. The new measurement procedures can lead to resonant and Brillouin fiber-optic gyros.

Fiber gyros are a variant of the Sagnac ring interferometer. A light beam from a laser source is divided in two beams by a beam splitter. The two new beams enter in opposite extremes of an almost closed path (in former Sagnac rings, a polygon with mirrors on the corners was used), travel in opposite directions around the path, and come back to the beam splitter. The splitter combines the two arriving beams and projects them on the screen of an interferometer, where the beams interfere, creating an interference fringe pattern.

The two beams travel equal distances, so they are in phase when they interfere. If the closed path rotates on its plane, one beam travels a longer distance than the other, and therefore its phase on arrival will lag the other beam's phase.

Notice that the two beams result from the splitting of an already existing beam generated by a single laser source. Therefore, contrary to what happens with the laser ring gyro, traveling different distances causes no frequency shift between the two beams, but only a phase shift. The shift between the beams' phases causes a stationary shift of the position of the interference fringes on the plane of the screen (and not the permanent wander of the fringes, as is the case for the ring laser's frequency shift).

As seen before, the difference of the paths' length is $\Delta L = 4A\Omega/c$, where A is the area enclosed by the closed path. With the same wavelength for the two beams, this difference in distance corresponds to a difference of phase $\Delta\phi = 2\pi\Delta L/\lambda = (8\pi A/c\lambda)\Omega$. As a result, the phase shift is proportional to the rotating rate of the gyro, Ω . However, for small devices with about 10 cm across, the proportionality constant is very small, on the order of 10^{-4} rad/rad \cdot s $^{-1}$, causing the phase shift $\Delta\phi$ to be very small when the rotation rate Ω is kept moderate.

One way of increasing the sensitivity is to increase dramatically the length L of the path, or the area A it encloses, but without increasing the size of the device. To achieve this purpose, the path is made with an optical fiber wound as a coil of several turns. Modern silicon fibers present an attenuation on the order of 0.2 dB/km, at a wavelength of 1550 nm.

Therefore, several hundreds or even thousands of meters of optical fiber can be used, almost without attenuation. The fiber is wound a number N_t of turns, and the total area enclosed to be considered in the equations is now $A' = N_t A$, where A is the area of the surface physically occupied by the device, which remains on the order of 10 cm or 20 cm in diameter. However, noise and other sources of signal perturbation increase with the length of the fiber. Even when special techniques are used to minimize these effects, they end up putting a limit on the maximum length of the fiber.

The rotating rate Ω cannot be measured by counting the number of fringes that shift in front of a photodiode, as was done in the case of the laser ring. Indeed, the distance of two consecutive fringes on the screen corresponds to a phase shift of $\Delta\phi = 2\pi$. For example, considering a one-coil path with a diameter of 10 cm and a wavelength $\lambda = 1550$ nm, that phase shift corresponds to the astounding turning rate of 15000 rad/s per fringe. Therefore, it is necessary to measure phase shifts much smaller than 2π by any method other than a simple digital count of the fringes.

In the fringe pattern, the light intensity does not vary abruptly between the bright and dark fringes. Instead, the light intensity has a sinusoidal variation between the fringes. Sensing both the illumination intensity and its gradient around a point is a way of detecting the position of that point with respect to the fringe pattern and therefore computing the phase shift. Many processes of detecting and measuring very small phase shifts, on the order of 10^{-7} rad, have been developed and implemented, some of them using sophisticated modulation techniques. Some of these modulation techniques rely on using some external physical action to modify the fiber's light propagation characteristics in a manner that these characteristics become direction dependent. Being non-reciprocal (direction sensitive), this additional action increases the difference in the behavior of the two beams, hence facilitating the measurement of the length variation ΔL .

One of the techniques consists of having two rings optically coupled so as to form a multipass optical resonator. One of the rings is a small rotating ring of fiber (only about 10 m long) that acts as rotation sensing coil. The Sagnac effect changes the frequency of resonance by an amount Δf proportional to the rotation rate Ω , and the frequency shift is measured (the equation for Δf is the same that was determined for the laser ring gyro). These devices are called resonance fiber-optic gyros (R-FOGs).

Another technique is based on the fact that mechanical vibrations (acoustic waves) can interact with light waves, causing a frequency shift of the light (Brillouin effect). This effect is induced in such a way that the two beams are affected differently. The result is that the two beams acquire different frequencies, behaving in a way similar to the laser ring gyros, although the physical mechanism is different. Devices based on this technique are called Brillouin fiber-optic gyros (B-FOGs).

Using fibers up to a thousand meters, and accurate interferometer methods of reading phase shifts, a sensitivity of up to the order of 10^{-2} degrees per hour is reached for I-FOGs, which is adequate for inertial navigation systems for aircraft. This kind of gyro is currently in use in commercial airplanes. R-FOGs and B-FOGs can have a sensitivity on two or three orders of magnitude higher.

BIBLIOGRAPHY

- G. Asch and P. Desgoutte, *Les Capteurs en Instrumentation Industrielle*, Cap. 9, "Capteurs Tachymétriques," Dunod, France: Georges Asch, 1987.
- A. Boros, *Electrical Measurements in Engineering*, New York: Elsevier, 1985.
- S. Ezekiel and H. J. Arditty, *Fiber-Optic Rotation Sensors and Related Technologies*, New York: Springer-Verlag, 1982.
- P. Hariharan, *Optical Interferometry*, New York: Academic Press, 1985.
- P. Hauptmann, *Sensor: Principles & Applications*, Englewood Cliffs, NJ: Prentice-Hall, 1991.
- K. Hotate, J. Dakin, and B. Culshaw, in *Optical Fiber Sensors Applications, Analysis, and Future Trends*, New York: Artech House, 1997.
- R. T. H. Kersten, J. Dakin, and B. Culshaw, in *Optical Fiber Sensors: Principles and Components*, New York: Artech House, 1988.
- A. S. Morris, *Principles of Measurement and Instrumentation*, Englewood Cliffs, NJ: Prentice-Hall, 1993.
- H. N. Norton, *Sensor and Analyzer Handbook*, Englewood Cliffs, NJ: Prentice-Hall, 1982.
- R. Pallás-Areny and J. G. Webster, *Sensors and Signal Conditioning*, New York: Wiley, 1991.
- J. Powers, *An Introduction to Fiber Optic Systems*, 2nd ed., Chicago: Irwin, 1997.
- T. Senbon and F. Hanabuchi, *Instrumentation Systems: Fundamentals and Applications*, New York: Springer-Verlag, 1991.
- B. Stieler and H. Winter, *Gyroscopic Instruments and Their Application to Flight Testing*, AGARD Flight Test Instrumentation Series, Vol. 15, North Atlantic Treaty Organization.
- D. Wobschall, *Circuit Design for Electronic Instrumentation, Analog and Digital Devices from Sensor to Display*, 2nd ed., New York: McGraw-Hill, 1987.

MÁRIO VENTIM NEVES
Technical University of Lisbon

TACKET TELEMETRY. See TELEMETRY.