

Before presenting some of the basic ideas that support the operating and implementing principles of volt-ampere meters, it is worth discussing the concepts of active power, reactive power, and apparent power.

Power is the rate at which energy is transferred or transformed into a different form. Active power P , also called true power, is physically related to the energy nonreversibly converted to heat (Joule effect) in the resistive components of electric circuits. Thus, in a resistor R with current i , P is given by

$$P = RI_{\text{rms}}^2 = \frac{U_{\text{rms}}^2}{R} = (ui)_{\text{av}} = \frac{1}{T} \int_T (ui) dt = (p)_{\text{av}} \quad (1)$$

where rms stands for root-mean-square, u is the voltage drop in R , p is the instantaneous power, T is the period of p , u and i represent instantaneous values, and U_{rms} and I_{rms} represent constant values.

Equation (1) is the basic definition of active power in a circuit. Active power is the time average of the product of instantaneous voltage and current (instantaneous power). When, and only when, voltage and current are sinusoidal, Eq. (1) yields the known relationship

$$P = U_{\text{rms}} I_{\text{rms}} \cos \varphi \quad (2)$$

where φ is the phase angle between u and i . The unit of active power is the watt (W).

Contrary to the active power which has a physical meaning, reactive power (R) and apparent power (S) are electrical quantities that have the dimensions of power but have significance only when voltage and current are sinusoidal or near sinusoidal. These two quantities are related to the behavior of the reactive components of circuits and their meanings result from interpreting the complex Poynting theorem (1). For a circuit under a sinusoidal regime,

$$R = U_{\text{rms}} I_{\text{rms}} \sin \varphi \quad (3)$$

$$S = U_{\text{rms}} I_{\text{rms}} = \sqrt{P^2 + R^2} \quad (4)$$

Reactive power is expressed in volt-ampere reactive (VAR) and apparent power in volt-ampere (VA).

TYPES OF VOLT-AMPERE METERS

Nowadays, because of the widespread use of personal computers (PCs) and PC data acquisition boards (DAQs), the design of multipurpose measuring instruments that function in particular as volt-ampere meters is a problem of software as well as hardware. And because the implementation of the hardware to digitize several electric voltages and currents is trivial in many situations, the measurement capacity of a PC with a DAQ depends mainly on the software component of such a measuring instrument, usually designated by a virtual instrument (VI). The use of object-oriented languages and the existence of commercial software packages supported and supporting visual programming has made life easier for VI designers and also for users, because those programming tools facilitate the implementation of instruments with user-friendly interfaces. It is our belief that in the near future PC-based virtual instrumentation will render obsolete many ded-

VOLT-AMPERE METERS

Volt-ampere meters are multipurpose electric measuring instruments that display the values of active, reactive, and apparent electric power. Some of them also measure other electric quantities, such as current, voltage, and energy.

icated analog and digital instruments still in use now, particularly in the laboratory. Volt-ampere meters will be no exception. Model TPZ 303 from ZERA Electric GMBH is an example of this type of instrumentation already available. It is a multifunction, high-accuracy (200 ppm for active power) measuring system based on the digitization of the input quantities and signal processing. Designed to be a portable stand-alone instrument, the processing unit is not an external PC but an internal digital signal processor (DSP). However, an overview of some of the other types of volt-ampere meters is justified, because instruments based on different operating principles are still manufactured and used, particularly in industry.

The presentation of volt-ampere meters that follows is organized according to the power measurement principles they use.

According to the measuring method, power meters may be divided into analog and digital types. In analog power meters, the measurement is obtained by an electric quantity that is proportional to the power. This quantity is produced by analog means and is displayed in either analog or digital format. In digital power meters, voltage and current are digitized and the measurement of power is obtained upon adequate reduction of the resulting data. Presentation of the results is usually digital. A VI power meter is an example of a digital power meter.

From Eqs. (1), (3) and (4), one may conclude that any idea that yields the analog product of two voltages or currents supports a power measuring principle and the design of an analog power meter (analog multiplication power meter). Those expressions also clearly identify the operations that the software of digital power meters must implement to produce the measurements.

In the case of active power, some analog meter designs are based on the physical meaning of active power. Examples of methods used are (1) measurement of the voltage or current in a known noninductive resistor by a thermogalvanometer or a thermocouple ammeter; (2) measurement by comparing the brightness of an incandescent lamp driven by the source of power to be measured by using a voltmeter, an ammeter, an incandescent lamp, and a photosensitive meter; (3) measurement of the temperature change when a temperature-sensitive resistor (bolometer) absorbs energy. The corresponding change of resistance is measured by a bridge circuit; (4) measurement of part of the heat produced in a resistor using the bolometer method (calorimetric active power meters). These methods may be used to implement low-frequency active power meters. Nevertheless, the meters commercially available are almost exclusively designed for the radio-frequency domain. For that reason, those types of meters are not considered in this article. Interested readers are directed to Refs. 2 and 3.

Reactive and apparent powers are important in power systems and so the solutions considered in the following paragraphs are used in low-frequency power meters.

ANALOG MULTIPLICATION POWER METER

Electrodynamic Principle (Electrodynamic Volt-Ampere Meters)

Electrodynamic instruments are analog instruments that have two coils, one fixed (current coil or current circuit) and

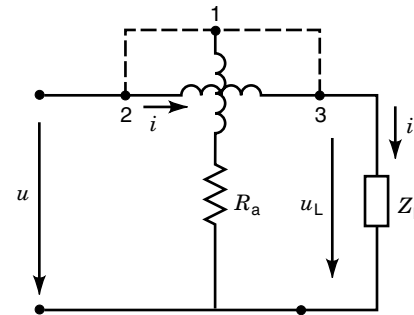

Figure 1. Connections of an electrodynamic wattmeter to a load Z_L . R_a is an additional resistance used in the voltage circuit.

the other able to rotate around an axis inside the first coil (voltage coil). For frequencies higher than 1 Hz (4) the change of the angular position α between the two coils is proportional to the time average of the product of the currents in the two coils:

$$\alpha = k(i_1 i_2)_{av} = k \frac{1}{T} \int_T i_1(t) i_2(t) dt \quad (5)$$

To measure the active power in a load Z_L , the two coils are connected as shown in Fig. 1. The instrument indicates the active power in the load added to the active power in either the current circuit (connection 1–2) or in the voltage circuit (voltage coil in series with resistor R_a , connection 1–3). Thus, to obtain the correct value of the active power in the load, the indication has to be corrected. For details, see Refs. 4 and 5. Equation (5) reveals that as long as i_1 and i_2 represent the load current and load voltage, the electrodynamic wattmeter measures the active power. The shape of the waveform does not limit the validity of the measurement.

To measure reactive power, the voltage circuit of the wattmeter (fixed coil and resistance in series) must be slightly changed. In fact, taking into account that the measuring situation is relevant only when sinusoidal waveforms are present, for which Eqs. (3) and (4) are valid, and also that

$$\sin \varphi = \cos \left(\varphi - \frac{\pi}{2} \right) \quad (6)$$

the reactive power may be measured if the current in the moving coil is not proportional to the load voltage, but to a voltage lagging the load voltage by $\pi/2$. Figure 2 shows the voltage circuit of an electrodynamic reactive power meter (electrodynamic varmeter) and the vector diagram of the pertinent electrical quantities. The vector diagram presented is valid only for one frequency ω , which means that the electrodynamic varmeter is a single-frequency varmeter. The measurements are correct only when the load current and voltage are sinusoidal at the frequency considered in the design of the instrument. Commercial electrodynamic varmeters for measurements at the frequency of the main power supply are more common.

The electrodynamic principle also allows constructing an instrument for measuring apparent power directly. For that purpose, the two coils of an electrodynamic instrument must be preceded by circuitry to output dc voltages or currents pro-

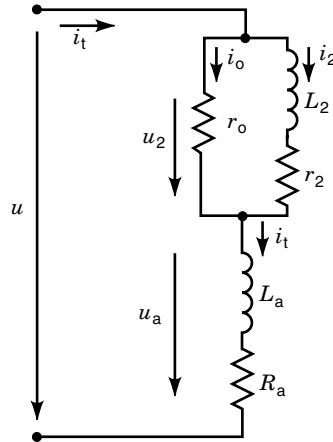
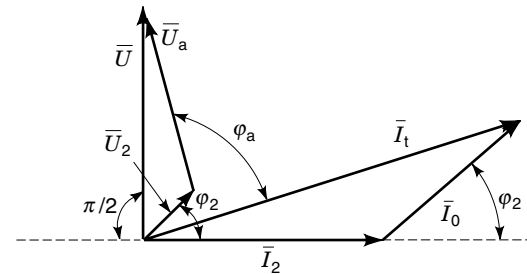

Figure 2. Voltage circuit of an electrodynamic varmeter and the corresponding vector diagram. The resistance r_0 is in parallel with the impedance of the voltage coil (r_2L_2). i_2 lags i_0 and by an appropriate choice of r_0 , R_a and L_a , i_2 lags the load u by $\pi/2$.



portional to the rms values of the voltage and current involved in the circuit under test. This solution, however, is not used in the practice.

The series connection of the two coils of an electrodynamic instrument transforms it into a true rms current meter (electrodynamic ammeter) for frequencies ranging from dc to a few hundred hertz. A resistor in series with the two windings transforms the ammeter into a true rms voltmeter (electrodynamic voltmeter). The upper frequency limit of electrodynamic voltmeters is also a few hundred hertz but slightly lower than for electrodynamic ammeters.

Readers interested in typical values and specifications for electrodynamic instruments, are directed to Refs. 4 and 5.

Thermoelectric Conversion Principle (Thermal Volt-Ampere Meters)

Analog multiplication related to the thermoelectric effect is achieved by using two thermoelectric converters in the configuration depicted in Fig. 3. Currents i_1 and i_2 are proportional to the voltage and current involved in the power to be

measured. The two thermoelectric converters are coupled, and their filaments (heaters) have resistances R_f . Because the circuit is symmetrical, the filament currents of the converters i_A and i_B are given by

$$i_A = \frac{1}{2}(i_1 + i_2) \tag{7}$$

$$i_B = \frac{1}{2}(i_1 - i_2) \tag{8}$$

These two currents produce two dc voltages U_A and U_B given by

$$U_A = k_C I_{A_{rms}}^2 = k_C (i_A^2)_{av} \tag{9}$$

$$U_B = k_C I_{B_{rms}}^2 = k_C (i_B^2)_{av} \tag{10}$$

where k_C is the constant of the converters.

Replacing Eq. (7) in (9) and Eq. (8) in (10) yields

$$U_A = \frac{k_C}{4} [(i_1 + i_2)^2]_{av} = \frac{k_C}{4} (i_1^2)_{av} + \frac{k_C}{4} (i_2^2)_{av} + \frac{k_C}{2} (i_1 i_2)_{av} \tag{11}$$

$$U_B = \frac{k_C}{4} [(i_1 - i_2)^2]_{av} = \frac{k_C}{4} (i_1^2)_{av} + \frac{k_C}{4} (i_2^2)_{av} - \frac{k_C}{2} (i_1 i_2)_{av} \tag{12}$$

$$U_1 = U_A - U_B = k_C (i_1 i_2)_{av} \tag{13}$$

Equation (13) reveals that the dc voltage U_1 of Fig. 3 is proportional to the active power, provided that i_1 and i_2 themselves are proportional to the voltage and current in the circuit.

To assemble an active power meter, the circuit of Fig. 3 must be complemented with a dc voltmeter to measure U_1 and with a resistor to convert the voltage in the circuit into i_1 or i_2 .

To implement either an apparent power meter or an ammeter or a voltmeter, the considerations before about the corresponding electrodynamic meters are valid. Constructing a reactive power meter based on thermoconverters is also possible. All that is required is to include a circuit before that of Fig. 3 to produce a lag of $\pi/2$ in the current representing the voltage of the circuit. An active integrator can be used as the basic building block of that circuit.

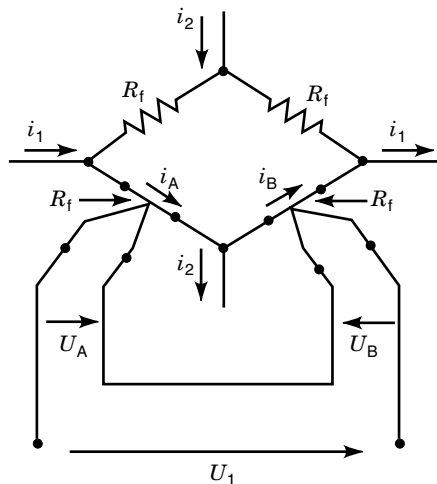

Figure 3. Thermoelectric power meter using two identical thermoelectric converters that have resistance R_f . The currents i_1 and i_2 , whose average product is to be measured, enter the circuit at opposite corners of the bridge.

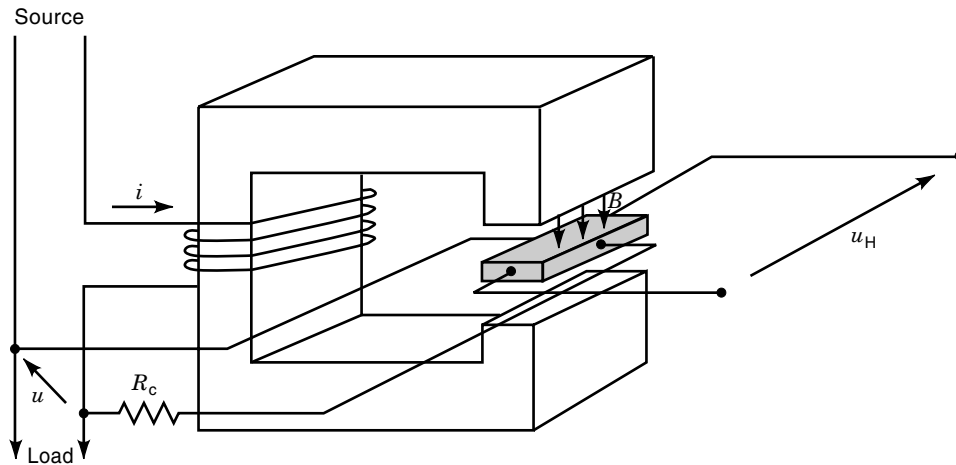

Figure 4. Hall effect analog power meter. The analog multiplication of the current and voltage comprised in the power is obtained by using the Hall effect principle. $B(t)$ is proportional to the current and i to the voltage in the circuit.

The thermoelectric analog multiplication just presented permits assembling wideband multipower meters because thermoelectric converters can be used at frequencies up to a few hundred megahertz.

Hall Effect Principle (Hall Effect Volt-Ampere Meters)

The Hall effect is a phenomenon that occurs in conductors and semiconductors but is particularly important in the latter. It consists of the appearance of a voltage u_H between two parallel faces of a parallelepiped semiconductor chip when the semiconductor is subjected to a current i and to a magnetic induction field B acting in the two other orthogonal directions. The relationship among the three quantities is given by

$$u_H = \frac{R_H}{d} i B(t) \quad (14)$$

where R_H is the so-called Hall coefficient of the material and d is its thickness. Figure 4 represents the circuit configuration for the analog multiplication of a voltage and a current using the Hall effect principle. The magnetic field in the semiconductor is proportional to the current in the circuit and the current in the semiconductor is proportional to the voltage in the circuit. Thus, the time averaging of u_H , which can be done by mechanical or electrical means, is proportional to the active power. In the first case, a d'Arsonval meter is usually used. In the second, an electronic integrator (active low-pass filter) is the more common solution.

As in the case of thermoelectric conversion, the Hall effect principle can support the design of a multipower meter for measuring active, reactive, and apparent power. However, as far as we know, only active power meters have been assembled and used. The direct field sensor (DFS) from Landis & Gyr is an example of applying the Hall effect to measuring active power and also electrical energy. DFS incorporates a Hall sensor, a custom chip, and additional circuit elements. Its main positive characteristics are: (1) accuracy better than 1%; (2) good stability and the possibility of automatic calibration, which leads to highly reliable maintenance-free meters; (3) very good electromagnetic immunity, in part because of its inherent galvanic isolation; and (4) the possibility of integrating functions, such as radio telemetry.

Feedback Time-Division Multiplier Principle (FTDM Volt-Ampere Meters)

Time-division multiplication is a technique of analog multiplication based on the concept that the area of an electric pulse is equal to the product of the pulse width and pulse height. The circuit represented in Fig. 5(a) is a possible hardware solution to implement an analog multiplier according to this concept. Because of its positive characteristics, nowadays the FTDM principle first introduced by Yokogawa Electric Works (YEW) is extremely popular among manufacturers of electronic volt-ampere meters.

The basic component of the multiplier is the mark space amplitude (MSA) converter [Fig. 5(b)]. In this converter, the duty cycle of a constant amplitude and period rectangular voltage is modulated by a voltage u_1 . Thus, and referring to Fig. 5(b),

$$T = T_1 + T_2 = k_1 \quad (15)$$

$$T_1 - T_2 = k_2 u_1 \quad (16)$$

where k_1 and k_2 are two constants. By multiplying the MSA output voltage u' with the other voltage u_2 occurring in the product, one obtains a voltage u'_0 :

$$u'_0 = u_2 (T_1 - T_2) = k_2 u_1 u_2 \quad (17)$$

This operation is performed by using an amplitude modulator and a low-pass filter [Fig. 5(a)].

The MSA Converter. The MSA converter represented in Fig. 5(b) was also introduced by YEW and is used, for instance, in its digital wattmeter model 2504.

The operation of the converter is as follows. A comparator compares a voltage u_c with a triangular waveform u_t (this voltage is internally generated in the model previously mentioned). When $u_c > u_t$, u' is positive ($u' > 0$) and S_1 switches so that u_0 becomes equal to $+U_{ref}$. When $u_c < u_t$, the comparator output voltage is negative, and S_1 changes to $-U_{ref}$.

If the frequency of the triangular waveform u_t is much higher than the frequency of u_1 and u_2 , then these voltages

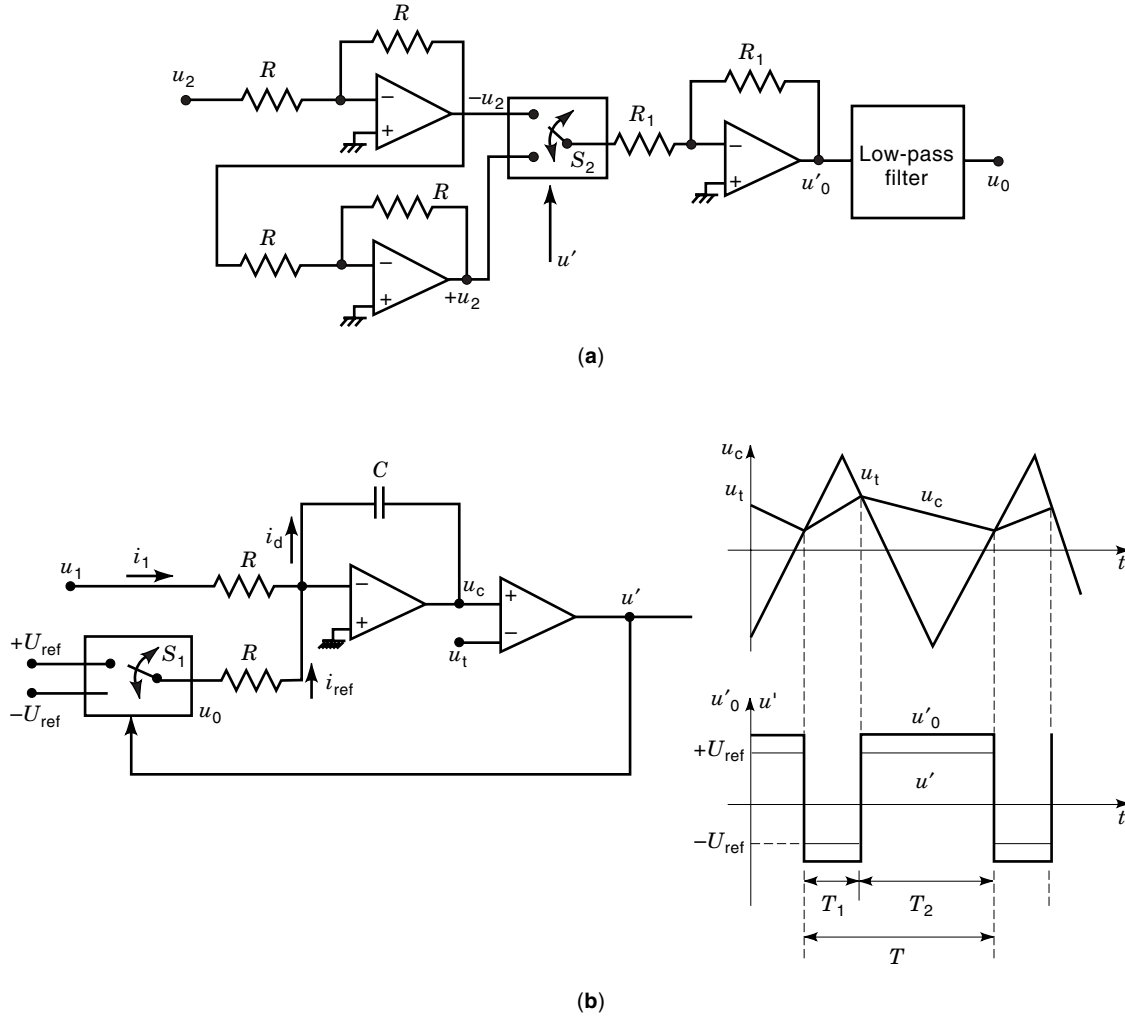

Figure 5. Time division multiplier: (a) amplitude modulator and low-pass filter. u' , the output voltage of the MSA converter, represented in (b), is multiplied by u_2 , and the average of this product is achieved by using a low-pass filter; (b) mark space amplitude converters. The duty cycle of a constant amplitude and period rectangular voltage, the output voltage u' , is modulated by a voltage u_1 .

can be considered constant compared with u_t . Thus, in the steady state, u_c should be periodic and $(i_d)_{av} = 0$ because u_c is the integral of this current. Thus,

$$T_1 \left(\frac{u_1}{R} - \frac{U_{ref}}{R} \right) + T_2 \left(\frac{u_1}{R} + \frac{U_{ref}}{R} \right) = 0 \quad (18)$$

$$(T_1 + T_2) \frac{u_1}{R} = (T_1 - T_2) \frac{U_{ref}}{R} \quad (19)$$

$$(T_1 - T_2) = T \frac{u_1}{U_{ref}} = k_2 u_1 \quad (20)$$

$$T_1 = \frac{T}{2} \left(1 + \frac{u_1}{U_{ref}} \right) \quad (21)$$

This means that T_1 is continuously adjusted by comparing u_c and u_t . If the average value of i_d is not zero, then the voltage u_c is not periodic but increases or decreases, changing the relationship between T_1 and T_2 . The steady state occurs when

$(i_d)_{av} = 0$. The action of the closed-loop set comparator switch is instrumental for that purpose.

The Amplitude Modulator and Low-Pass Filter. Referring to Fig. 5(a), and taking into consideration that the output voltage u' of the comparator of the MSA converter controls switch S_2 ,

$$u'_0 = \begin{cases} +u_2 & \text{if } u' < 0 \\ -u_2 & \text{if } u' > 0 \end{cases} \quad (22)$$

and thus,

$$\begin{aligned} u_0 &= (u'_0)_{av} = \frac{1}{T} \int_T u'_0(t) dt = \frac{1}{T} [u_2 T_1 - u_2 (T - T_1)] \\ &= \frac{1}{T} [2u_2 T_1 - u_2 T] = \frac{1}{T} \left[2u_2 \frac{T}{2} \left(1 + \frac{u_1}{U_{ref}} \right) - u_2 T \right] = \frac{u_1 u_2}{U_{ref}} \end{aligned} \quad (23)$$

The FTDM principle for analog multiplication can be used for active, reactive, or apparent power measurement. Naturally, the voltage and current of the circuit test must be conditioned before they are applied to the multiplier input. In the case of the current, the conditioner must include a current-to-voltage converter using, for instance, a shunt resistor and an operational amplifier.

For active power measurement, the output voltage u_0 of the circuit of Fig. 5(a), must be averaged by another low-pass filter, usually by electronic means.

For reactive power measurement, the voltage of the circuit test must be lagged by $\pi/2$ before it is input to the FTDM. That lag is easily obtained from electronic circuitry and, thus, it is performed after the voltage input conditioner. The output of the multiplier must also be low-pass filtered to yield the reactive power value.

For apparent power, the easiest solution involves two rms converters placed between the input conditioners and the multiplier. The product of the two dc voltages output by the rms converters indicates the value of the apparent power.

The measurement of voltage and current is also easily implemented by using the FTDM multiplier. For that purpose, it is sufficient to connect the output of the voltage conditioner or of the current conditioner to both inputs of the multiplier.

Several FTDM volt-ampere meter manufacturers, such as YEW, Dranetz, Landis & Gyr, and Schlumberger offer energy counters based on the FTDM multiplying principle. In fact, all that it is required is to add an integrator to the active power meter. In the YEW wattmeter model 2504, the integrator is a stand-alone instrument (YEW 2513).

Logarithmic Conversion Principle

One easy way of performing the analog multiplication of two electric quantities (voltages or currents) is with logarithmic amplifiers (6). In fact, because

$$\log(ab) = \log a + \log b \quad (24)$$

the logarithmic conversion of two quantities transforms its product into a sum, easily achieved by using operational amplifiers. Applying the inverse function to Eq. (24) the product of the two quantities a and b is given by

$$\log^{-1}[\log(ab)] = ab = \log^{-1}(\log a + \log b) \quad (25)$$

Figure 6 presents a circuit based on logarithmic and antilogarithmic converters which multiplies u_1 and u_2 . The first module uses two identical logarithmic converters, whose output voltages are related to the input voltages by

$$\begin{aligned} u_{01} &= -k_1 \log_{10} \frac{u_1}{RI_{\text{ref}}} \\ u_{02} &= -k_1 \log_{10} \frac{u_2}{RI_{\text{ref}}} \end{aligned} \quad (26)$$

where

$$k_1 = \frac{R_T + R_1}{R_T} \cdot \frac{kT}{q} \cdot \frac{1}{0.434} \quad (27)$$

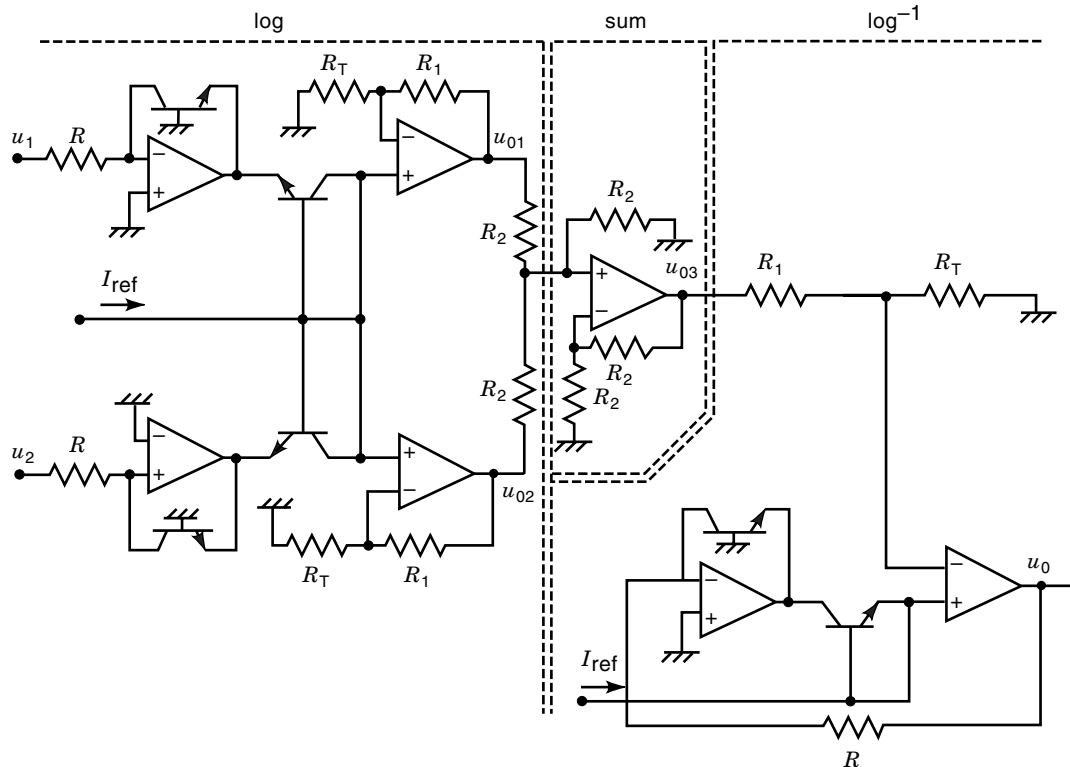

Figure 6. Analog multiplication using logarithmic and anti-logarithmic amplifiers: $u_{01} \propto \log u_1$; $u_{02} \propto \log u_2$; $u_{03} \propto \log u_1 + \log u_2$; $u_0 \propto \log^{-1}(u_{03}) = \log^{-1}(\log u_1 + \log u_2) = u_1 u_2$.

In Eq. (27), k is the Boltzmann constant (1.38×10^{-23} J·K⁻¹), T is the absolute temperature of the semiconductor junctions, and q is the charge of the electron (1.6×10^{-19} C).

The operational amplifier of the intermediate stage provides

$$u_{03} = -k_1 \log_{10} \frac{u_1 u_2}{R^2 I_{\text{ref}}^2} \quad (28)$$

The final module performs the antilogarithmic operation. The output voltage is proportional to the antilogarithmic of the input voltage

$$u_0 = RI_{\text{ref}} \log_{10}^{-1} \left[k_1 \times \frac{\log_{10} \left(\frac{u_1 u_2}{R^2 I_{\text{ref}}^2} \right)}{k_1} \right] = \frac{u_1 u_2}{RI_{\text{ref}}} \quad (29)$$

Implementing power meters using this principle is fairly easy but leads to instruments with moderate performance. In fact, the existence of logarithmic and antilogarithmic amplifiers and of log/antilog multipliers as integrated circuits (e.g., Burr-Brown 4127, Burr-Brown 4302) simplifies designing and constructing power meters. However, such components are either inexpensive and moderately accurate or they perform well, but then they are quite expensive. For that reason volt-ampere meters based on this type of component are not popular and are limited to applications demanding only low accuracy (not less than 1%).

As long as the multiplier block operates with positive and negative input voltages (four-quadrant multiplier), its functionality, from the viewpoint of the terminal voltages, is similar to that of the FTDM. This means that the considerations in the previous section regarding circuitry for measuring the different types of power, voltage, current and even energy are still pertinent.

Other Solutions for Electric Analog Multiplication

Two other types of solutions for analog multiplication of two voltages (or currents) are worth a short discussion.

The first has its origin in the following relationship:

$$(a + b)^2 - (a - b)^2 = 4ab \quad (30)$$

The circuitry used to implement this idea also involves, in general, logarithmic amplifiers, and thus this type of multiplier is considered a variation of the log/antilog multiplier mentioned in the preceding paragraph.

In the second type we include several different multipliers that are based on different principles but have two aspects in common. They are electronic multipliers, and they are available as integrated circuits. The so-called transconductance principle (7,8) is an example of a principle used, for instance, in Burr-Brown MPY 100 and in Harris ICL8013.

DIGITAL POWER METER

The digitization of low-frequency electrical voltages and currents is presently achieved simply and at low cost. It originated from low cost, high-performance, and reliable analog and digital integrated circuits. The basic blocks of a digitizing

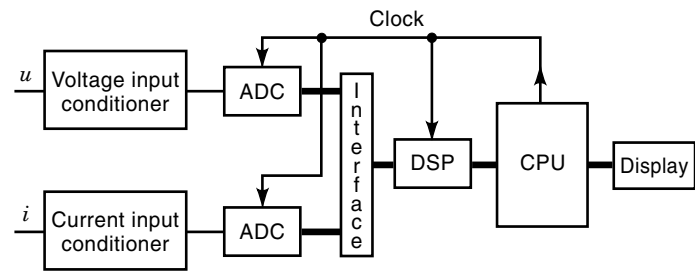

Figure 7. Digital power meter: after digitizing the voltage and current, the CPU reduces the data to compute the active, reactive, or apparent power.

system are naturally the sample-and-hold and the analog-to-digital converter. The performance of digitizing systems is highly dependent on the performance level of those components. Notwithstanding, the advances in digital circuits for control, data processing, data storage, and data transmission led to the replacement, whenever possible, of analog measuring methods by digital measuring methods. This trend is also felt in the domain of low-frequency power and energy measurements. As already mentioned, active power, reactive power, and apparent power are measured digitally in two steps. First, the voltage and current are simultaneously converted to digital words, and then the resultant data is digitally processed by some processing unit. This means that two equally important components are involved in the operation of this type of power meter, the hardware and the software. The routines that constitute the software can be quite different from instrument to instrument. The hardware components of the instruments have, however, some similarities. Figure 7, which represents the implementation used by Yokogawa in models WT110/WT130, gives a good picture of the building blocks of a typical low-frequency multipower meter.

This instrument consists of various sections: input circuits (voltage and current input circuits), a digital signal processor (DSP), a central processing unit (CPU), a display and interface circuits.

In the voltage input conditioner, the input voltage is attenuated and then sent to an analog-to-digital converter (ADC). In the current input conditioner, the current involved is converted into a voltage by using a shunt resistor. Then the voltage is amplified and formalized by an operational amplifier before entering another ADC converter. The outputs from both ADC converters are sent to the digital signal processor (DSP). The DSP reduces the data to produce the values of voltage, current, and active power for each sampled datum sent from the ADC converter. After processing a certain number of sets of data, computation of the apparent power, reactive power, power factor, and phase angle starts. Computational results are sent to the CPU where computations, such as range conversion and scaling, are carried out. Display and outputs are also controlled by the CPU. The output goes to a readout driver (display).

GENERAL CONSIDERATIONS

Although the measurement of active power is important in different frequency domains, reactive power and apparent power measurements are required basically in power sys-

tems. The measuring principles discussed take that into account.

In power systems, it is often necessary to measure the three-phase power and energy. It is worth mentioning that some measuring methods, such as the Aron method, avoid the use of three volt-ampere meters. Interested readers are directed to Chapter VI of Ref. 4 and Chapter 6 of Ref. 5.

Excluding electrodynamic volt-ampere meters, all of the analog multiplication power meters considered are built around a block that produces a voltage (or current) proportional to the product of the current and voltage of the circuit under test. The meter hardware must be complemented with a voltage (or current) measuring device and with input conditioning circuitry whose composition depends on the quantity to be measured by the power meter and on its accuracy. For measurements in the range 45 to 65 Hz with accuracy better than 0.5%, the input circuits include current and voltage transformers or, less often, voltage dividers and current shunts. These components, that reduce the amplitude of the input current and voltage to levels accepted by the electronic components, are the front end of the meters and much of the meters performance depends on the metrological characteristics of such passive components. The reader should take the solutions considered in the text as guidelines for understanding the internal composition of those types of volt-ampere meters.

The following values are typical for the accuracy of volt-ampere meters: analog type—0.1% to 2% full-scale value (FSV); digital type—0.2% to 2% FSV. Presently, the standards used for calibration are usually of the FTDM type (e.g., YEW 2855) whose accuracy is around 0.02% FSV.

In this article, we elected to separate volt-ampere meters into analog and digital types according to the principle of measurement they use, but this classification is not universal. In fact, most manufacturers use the term digital whenever the meter displays the measurement numerically. The reader must be aware of this fact when consulting different manufacturers' catalogs.

BIBLIOGRAPHY

1. S. Ramo, J. R. Whinnery, and T. Van Duzer, *Fields and waves I*, Communication Electronics, New York: Wiley, 1984, Chap. 3.
2. H. M. Berlin and F. C. Getz, Jr., *Principles of Electronic Instrumentation and Measurement*, Columbus, OH: Merrill, Chap. 6, 1988.
3. B. M. Oliver and J. M. Cage, *Electronic Measurements and Instrumentation*, New York: McGraw-Hill, 1975, Chap. 16.
4. P. Jacobs and V. Jadin, *Mesures Électriques*, Paris: Dunod, 1968, Chap. II.
5. M. Stockl and K. H. Winterling, *Elektrische Messtechnik*, Stuttgart: Teubner, 1973, Chap. 2.
6. T. T. Lang, *Electronics of Measuring Systems*, New York: Wiley, 1987, Chap. 5.
7. Integrated Circuits Data Book—Linear Products, Burr-Brown Corporation, Tucson, AZ.
8. Linear & Telecom ICs for Analog Signal Processing Applications, Harris Semiconductor, Melbourne, FL.

PEDRO M. B. SILVA GIRÃO
ANTÓNIO M. CRUZ SERRA
HELENA M. GEIRINHAS RAMOS
Instituto Superior Técnico