

HYGROMETERS

Introduction

The presence or absence of water vapor in air or other gas influences a vast range of physical, chemical, and biological processes. Humidity measurements are important for a wide range of industries and to some they are a critical aspect of business costs, product quality, and health and safety.

There are many different techniques for measuring humidity. The subject is also complicated by the confusing variety of ways of expressing humidity. As for other fields of measurement, a consistent and harmonized approach to humidity measurement is increasingly important, as is a common understanding of humidity terms and definitions.

Humidity is a relatively difficult quantity to measure in practice, and the accuracy achievable is not as good as for many other areas of measurement. For example, the mass of objects can be found by weighing in a typical laboratory to within 1 part in 100,000. Similarly, atmospheric pressures can often be measured to within 5 parts in 10,000. Humidity, however, can commonly be measured to only about 3 parts in 100, that is, with an uncertainty in the result of $\pm 3\%$.

To make a reliable humidity measurement at any given level of accuracy, it is necessary to use an appropriate measuring technique in a sound way. To do so, one must be able to define the measurement task, select a suitable method of measurement underpinned by reliable calibration, carry out the measurement correctly without introducing errors, and interpret the result of the measurement.

Water in Air or Gases. The word “humidity” denotes the presence of water vapor in air or other gas. Water vapor is the gaseous form of water and can be thought of much like any other kind of gas. It is normally transparent, and makes up about one hundredth (or 1%) of the air around us.

Humidity arises in practice because, in the same way that hot water gives off steam, so water at lower temperatures—including ice—also gives off water vapor. Wherever there is water or ice, there is evaporation (or its opposite, condensation). The extent to which this happens depends on a number of factors, the most important of which is temperature. Similarly, other liquid or solid materials—most of which have some water content—will give off (or sometimes soak up) water vapor. Of course, water vapor can also be found in places where there is no liquid or solid nearby, for example, in remote parts of the Earth’s atmosphere.

Air (or empty space, or any other gas) has a given capacity to absorb water vapor. This capacity depends mainly on temperature. Generally speaking, the hotter the air, the more water vapor it can hold. At any particular temperature, air that contains its full capacity of water vapor, is said to be “saturated.” The “relative humidity” of the air expresses how fully saturated it is with water vapor. A variety of other (“absolute”) measures are used to express how much water vapor is actually present (regardless of temperature or level of saturation). Definitions and explanations of the most important of these terms are given in the next Section.

Humidity Terms and Definitions. Some vocabulary specific to humidity (and other common words with specialized meanings in this context) are as follows:

2 HYGROMETERS

Absorption (of water vapor)—retention (of water vapor) by penetration into bulk of a material

Adsorption (of water vapor)—retention (of water vapor) as a surface layer on a material

Condensate—condensed material, such as liquid water or ice

Desorption—release of adsorbed or absorbed substance

Humidity—the presence of water vapor in air or other gas. Some people use the word *humidity* to mean relative humidity only. Strictly speaking, “humidity” also refers to all kind of absolute indications of humidity. For very low humidities, other more specific terms tend to be used.

Hygrometer—any instrument for measuring humidity

Hygroscopic—tending to absorb water vapor

Absolute humidity—The mass of water vapor present in unit volume of moist air of a given temperature and pressure. *SI* (metric) units are grams of water per cubic meter of air (g m^{-3}). Older references may be in terms of pounds per million cubic feet (lb ft^{-6}) or in grains per cubic foot (gr ft^{-6}) or in grains per cubic foot (gr ft^{-1}). (One grain \approx 0.0648 gram.)

Dew point (or dew-point temperature)—The temperature at which dew, or condensation, forms on cooling a gas. This is, in effect, the temperature at which air becomes saturated in equilibrium with water. Expressed in degrees Celsius ($^{\circ}\text{C}$) or occasionally in other units of temperature (e.g., in degrees Fahrenheit ($^{\circ}\text{F}$) in the United States).

Relative humidity—The ratio of the actual vapor pressure to the saturation vapor pressure over a plane liquid water surface at the same temperature, expressed as a percentage. This is commonly understood when the term “X percent relative humidity” is used.

Saturation vapor pressure (of water)—maximum pressure of water vapor that can exist at a given temperature. Expressed in units of pressure, such as in pascals (*Pa*), or in non-SI units such as millibars (*mbar*) or millimeters of mercury (*mm Hg*).

Vapor pressure—that part of the total pressure contributed by the water vapor. Expressed in units of pressure, such as in pascals (*Pa*), or in nonmetric units such as millibars (*mbar*) or millimeters of mercury (*mm Hg*).

Types

In the past moisture in the air or other gas was measured by mechanical hygrometers. Today there are a number of hygrometer types available, the following being the mostly frequently used: mechanical, wet- and dry-bulb, adsorption, dew-point, impedance, piece electric, electrolytic and optical fiber hygrometers.

Mechanical Hygrometers

In a simple mechanical type of hygrometer the sensing element is usually an organic material that expands and contracts with changes in the moisture in the surrounding air or gas. The material used most often is human hair. Other materials may be paper, animal tissues, and wood. As illustrated in Fig. 1, a bundle of hair is held under slight tension by a spring, and a magnifying linkage actuates a pointer. The usually designed operating range of this type of hygrometer is from about 4°C to 38°C . For very short periods these hygrometers may be used down to 0°C and up to 60°C . When used within the range of usual room conditions, these instruments show very little drift in their measurement over periods of a year or more, but if exposed for any length of time to extremes of humidity or temperature, a permanent change in the sensitive material may result. The time required to respond fully to a sudden wide change of humidity may be as much as 5 min (1).

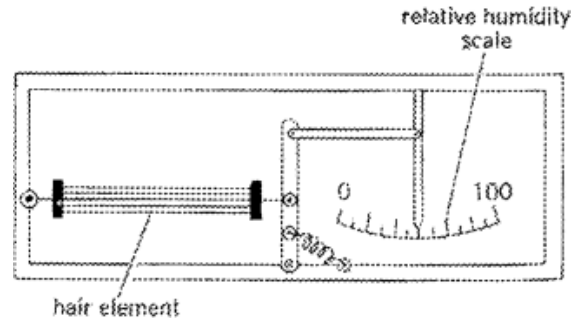

Fig. 1. Hygrometer that uses hair as the sensing element.

Wet- and Dry-Bulb Hygrometers

A wet- and dry-bulb hygrometer consists of two matched temperature sensors over which humid air is drawn. One sensor is enclosed in a porous medium (wick or “wet sock”) which is maintained wet by capillary action from a reservoir of water. Water evaporates from the wick at a rate related to the humidity of the air. The evaporation causes the wet sensor to be chilled. The temperatures of the wet and dry sensors are used to calculate the humidity of the air. Relative humidity from vapor pressure is determined by Eq. (1):

$$\text{Relative humidity (in\%)} = \frac{p_d}{p_s} \times 100 \quad (1)$$

where p_d is the actual vapor pressure of water and p_s is the saturation vapor pressure of water at the prevailing temperature and barometric pressure (2). Water vapor pressure, p_d , in air is found from the actual or dry-bulb temperature t and the wet-bulb temperature t_w using the equation

$$p_d = p' - A \cdot P \cdot (t - t_w) \quad (2)$$

where p' is the saturation vapor pressure of water at temperature t_w , P is the total barometric pressure (in the same units), and A is a coefficient established for the psychrometer. Widely recognized values of A for t_w above 0°C are:

$A = 6.66 \times 10^{-4} \text{ }^\circ\text{C}$ for moving air as in the Assmann ventilated psychrometer

$A = 8.0 \times 10^{-4} \text{ }^\circ\text{C}$ in a Stevenson screen as used by the Meteorological Office

The values of A given above yield approximate values of humidity, to which corrections can be added or subtracted, on the basis of a traceable humidity calibration. Alternatively, on the basis of a calibration of a given psychrometer, an individual value or formula for A may be assigned for that particular instrument. The use of a particular value of A is only valid if the correct conditions of air flow are provided for the instrument in question. An aspirated psychrometer with a fan for adequate air flow over the thermometers is the recommended basis for this measurement. Other approaches, such as Mason’s (nonaspirated) psychrometers and whirling (hand aspirated) psychrometer, are less successful realizations of this principle and are prone to errors, as are “home-made” psychrometers (2).

4 HYGROMETERS

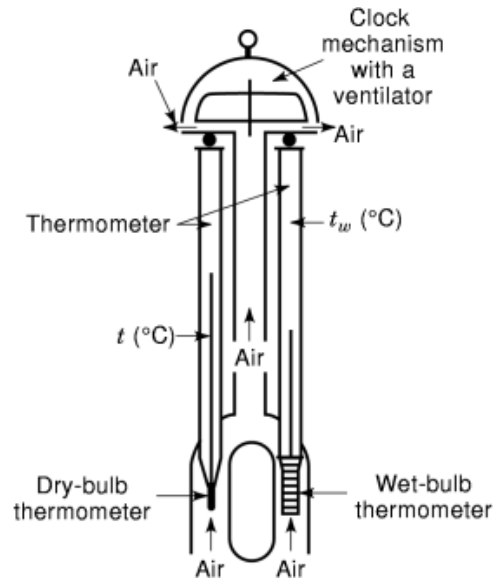

Fig. 2. Assmann's aspirated psychrometer (4).

Psychrometer. The psychrometer consists of the wet- and dry-bulb thermometers. Their temperature difference (psychrometric difference) enables the relative humidity to be calculated. The basis for calculation is Sprung's psychrometric approximate formula (3).

$$p_d = p_f - k \cdot (t_{tr} - t_f) \cdot p \text{ in mbar}$$

t_{tr} = the temperature of the dry-bulb thermometer in °C

t_f = the temperature of the wet-bulb thermometer in °C

p_d = the partial vapor pressure of water in mbar

p_f = the vapor pressure at the temperature of the wet-bulb thermometer in mbar

$$k = \text{constant} = 0.61 \times 10^{-3} \text{ } ^\circ\text{C}^{-1} \text{ for water/air}$$

$$= 0.57 \times 10^{-3} \text{ } ^\circ\text{C}^{-1} \text{ for ice/air}$$

We can obtain a much better result if the measured air passes by the wet-bulb thermometer with a velocity of approximately 2 m/s. In case of nonventilated air the measurement is very inaccurate. For practical measurement the Assmann's aspirated psychrometer is the most widely used. Figure 2 shows its construction which uses a small clock mechanism with ventilator (nowadays the electric ventilator) to artificially create the air flow.

Relative humidity may be determined by comparing temperature readings of wet- and dry-bulb thermometers as in Fig. 3 (4). Table 1, extracted from more extensive US National Weather Service tables, gives the relative humidity as a function of air temperature t_d (dry bulb) and the difference $t_d - t_w$ between dry- and wet-bulb temperatures (t_w = wet-bulb temperature) (5). The data assume a pressure near normal atmospheric pressure and an instrumental configuration with forced ventilation.

Table 1. Determination of Relative Humidity from Wet- and Dry-Bulb Temperatures (5)

t_d (°C)	$t_d - t_w$ (°C)											
	0.5	1.0	1.5	2.0	2.5	3.0	3.5	4.0	4.5	5.0	5.5	6.0
-10	83	67	51	35	19							
-8	86	71	57	43	29	15						
-6	88	74	61	49	37	25	8					
-4	89	77	66	55	44	33	23	12				
-2	90	79	69	60	50	40	31	22	12			
0	91	81	72	64	56	46	38	29	21	13	5	
2	91	84	76	68	60	52	44	37	29	22	14	7
4	92	85	78	71	63	57	49	43	36	29	22	16
6	93	86	79	73	66	60	54	48	41	35	29	24
8	93	87	81	75	69	63	57	51	46	40	35	29
10	94	88	82	77	71	66	60	55	50	44	39	34
12	94	89	83	78	73	68	63	58	53	48	43	39
14	95	90	85	79	75	70	65	60	56	51	47	42
16	95	90	85	81	76	71	67	63	58	54	50	46
18	95	91	86	82	77	73	69	65	61	57	53	49
20	96	91	87	83	78	74	70	66	63	59	55	51
22	96	92	87	83	80	76	72	68	64	61	57	54
24	96	92	88	84	80	77	73	69	66	62	59	56
26	96	92	88	85	81	78	74	71	67	64	61	58
28	96	93	89	85	82	78	75	72	69	65	62	59
30	96	93	89	86	83	79	76	73	70	67	64	61
35	97	94	90	87	84	81	78	75	72	69	67	64
40	97	94	91	88	85	82	80	77	74	72	69	67

t_d (°C)	$t_d - t_w$ (°C)														
	6.5	7.0	7.5	8.0	8.5	9.0	10.0	11.0	12.0	13.0	14.0	15.0			
4	9														
6	17	11	5												
8	24	19	14	8											
10	29	24	20	15	10	6									
12	34	29	25	21	18	12	5								
14	38	34	30	26	22	18	10								
16	42	38	34	30	26	23	15	8							
18	45	41	38	34	30	27	20	14	7						
20	48	44	41	37	34	31	24	18	12	6					
22	50	47	44	40	37	34	28	22	17	11	6				
24	53	49	46	43	40	37	31	26	20	15	10	5			
26	54	51	49	46	43	40	34	29	24	19	14	10			
28	56	53	51	48	45	42	37	32	27	22	18	13			
30	58	55	52	50	47	44	39	35	30	25	21	17			
32	60	57	54	51	49	46	41	37	32	28	24	20			
34	61	58	56	53	51	48	43	39	35	30	26	23			
36	62	59	57	54	52	50	45	41	37	33	29	25			
38	63	61	58	56	54	51	47	43	39	35	31	27			
40	64	62	59	57	54	53	48	44	40	36	33	29			

6 HYGROMETERS

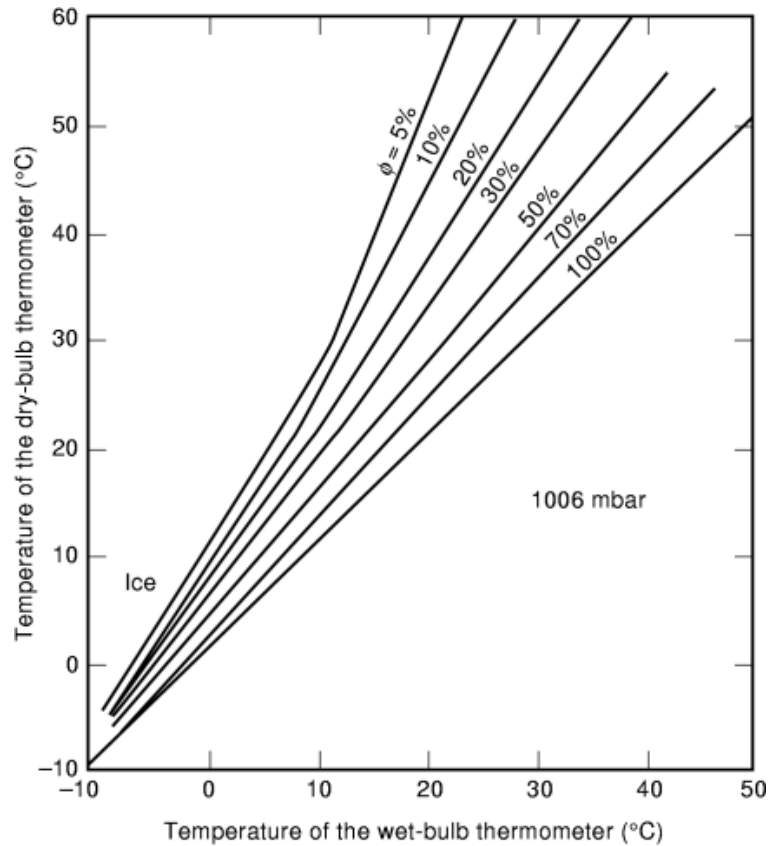

Fig. 3. Psychrometric diagram for determining the relative humidity of the air from the reading of the temperature of wet- and dry-bulb thermometers.

The psychrometer is principally suited to large spaces and medium or high humidities. The uncertainty of measurement is around $\pm 2\%$ rh to $\pm 5\%$ rh, at best.

Following are advantages(+) and disadvantages(-) of wet- and dry-bulb hygrometers:

- + Psychrometers are relatively simple, cheap, reliable, and robust instruments
- + Can have good stability
- + Tolerate high temperatures and condensation
- Some skill is usually required to use and to maintain the instrument
- Results may have to be calculated from temperature readings (although some are automatic)
- A large air sample is required for the measurement
- The sample will be humidified by wet-sock evaporation
- Airborne particles or water impurity may contaminate the wick; this can and should be remedied by regular cleaning or replacement
- Measurement can be complicated below about 10°C because of the uncertainty regarding the presence of water or ice on the wick when the temperature falls below 0°C

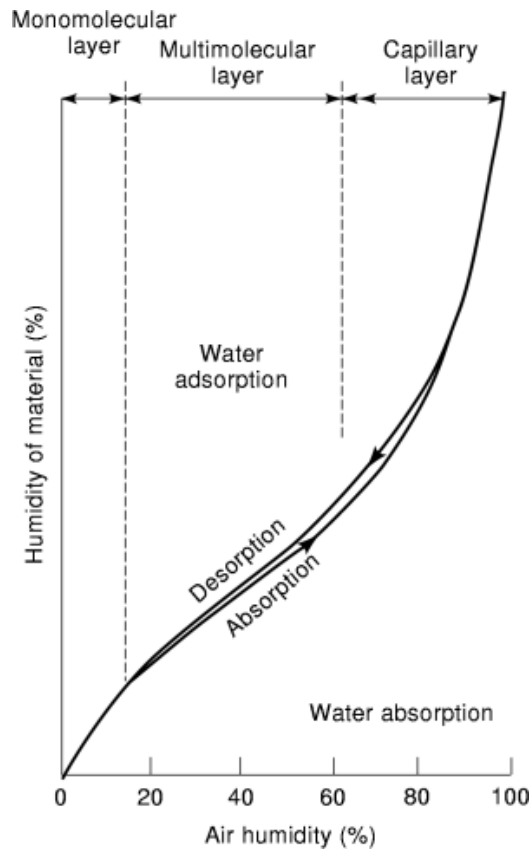

Fig. 4. Absorption–desorption characteristics. The humidity of material exposed to increasing air humidity rises according to absorption curve. The humidity of material exposed to decreasing air humidity drops according to desorption curve.

Adsorption-Type Hygrometers

Adsorption-type humidity measurement is based on the phenomenon a hygroscopic material gives off water according to absorption–desorption hysteresis as shown in Fig. 4 (6).

Centrifugal Method. This method is based on a well-known desorption method of relative humidity determination in alkaline solutions. In the case of cellulose, for instance, the cellulose fiber is first plunged into hydrochloric acid. With the help of centrifugation (desorption method), humidity is adsorbed from fiber, as can be seen in Fig. 4. Thus the degree of humidity in cellulose fiber can be controlled with the rate of centrifugation (7,8).

Hygrometers Based on Adsorption of Ceramic

Adsorption of gases is an important property of solid surfaces. There are probably at least two different types of adsorption, namely, physisorption and chemisorption. Adsorption isobars often appear like those shown in Fig. 5 (9). Three or more regions are found for the adsorption of a particular gas on a particular solid.

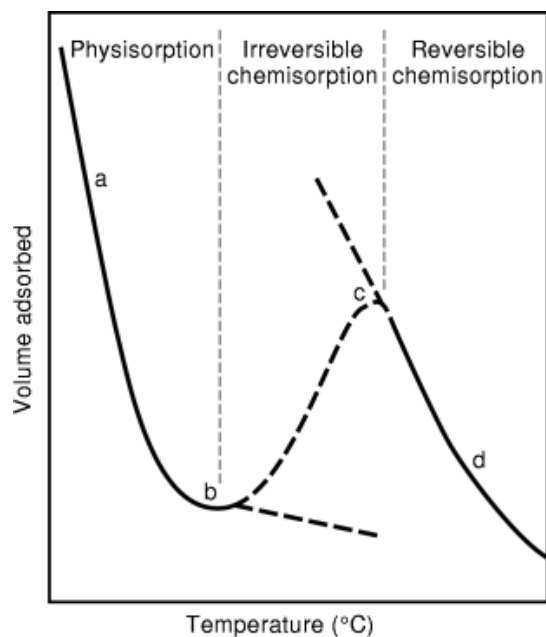

Fig. 5. Adsorption isobar. The three adsorption regions of a particular gas on a particular solid (*a–b* physisorption, *b–c* irreversible chemisorption, *c–d* reversible chemisorption).

At low temperatures of region *a–b*, physisorption occurs, where the surface coverage is at equilibrium and decreases with increasing temperature (Fig. 5).

At some temperatures in region *b–c*, irreversible chemisorption occurs. The activation energy increases with coverage, and the rate of adsorption decreases with coverage. If at each temperature the outgassed sample is permitted to adsorb gas for a given time, a curve shaped as indicated by the dashed line may be obtained. At this temperature, desorption will not occur by simply lowering the pressure. High-temperature outgassing is required (Fig. 5).

At temperatures high enough to overcome the activation energy (region *c–d*), reversible chemisorption is in principle reached, and the volume chemisorbed decreases with increasing temperature. However, behavior in this high-temperature region is often masked by chemical reactions (Fig. 5).

The surfaces of most metal oxides usually exhibit a complex structure comprising metal ions, oxygen ions, impurities, and imperfection. Thus there are many interactions between adsorbates and surface state. In atmospheres containing water vapor, for example, the surfaces of metal oxides are covered by hydroxyl groups on which water molecules adsorb through formation of hydrogen bonds. The surface hydroxyl groups can generally be removed by dehydration at higher temperatures. However, the surface structure of metal oxides in powder form is easily subject to permanent change by repeated heat-cleaning cycles at high temperatures. On the other hand, a ceramic body sintered at high temperature is essentially more stable physically, chemically, and thermally than the powder form. As with many porous systems, controlled-pore ceramics adsorb gases throughout the pore structure. The adsorption of gases generally tends to occur preferentially on the necks of the grain surfaces. The neck usually exhibits properties closely related to the crystal grain itself. In particular, a metal oxide ceramic semiconductor tends to exhibit changes in electrical conductivity due to the adsorption of gases on the necks.

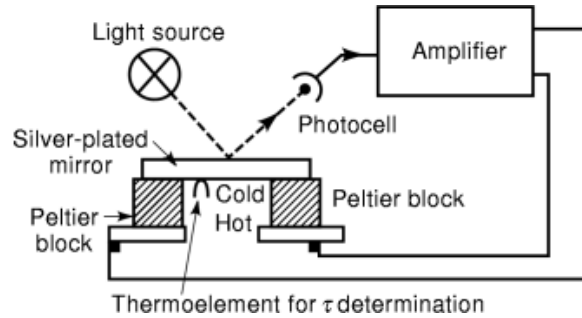

Fig. 6. Dew-point hygrometer by a Peltier element. The appearance of dew on the metal mirror changes the reflected light flow.

Dew-Point Hygrometer

The relative humidity may be determined from the dew point at the temperature, t_d , at which the humidity in the air condenses when the mixture is cooled from an initial temperature t . A simple equation relating saturation vapor pressure and dew point is the Magnus formula (3). At a temperature t ($^{\circ}\text{C}$), the saturation vapor pressure $e_w(t)$, in pascal, over liquid water, is

$$\ln e_w(t) = \ln 611.2 + \frac{17.62t}{243.12 + t} \quad (3)$$

The Magnus formula given above can be restated in alternative form, to derive dew point values from vapor pressure. For vapor pressure e_w (Pa) over water, the dew point t_d ($^{\circ}\text{C}$) is given by

$$t_d = \frac{243.12 \cdot \ln(e_w/611.2)}{17.62 - \ln(e_w/611.2)} \quad (4)$$

(100 Pa = 1 mbar). The uncertainty in values of t_d given by this equation is less than $\pm 0.04^{\circ}\text{C}$ in the range -45°C to $+60^{\circ}\text{C}$. For vapor pressure e_i over ice, the frost point t_i (in $^{\circ}\text{C}$) is given by

$$t_i = \frac{272.62 \cdot \ln(e_i/611.2)}{22.46 - \ln(e_i/611.2)} \quad (5)$$

The uncertainty in values of t_i given by this equation is less than $\pm 0.08^{\circ}\text{C}$, in the range -65°C to $+0.01^{\circ}\text{C}$ (10).

Dew-Point Hygrometer Using a Peltier Element. In modern dew-point hygrometers a small silver-plated mirror is placed in the measured air flow and cooled with the help of a Peltier element (Fig. 6). The latter, together with the amplifier and the thermoelement, enables the dew-point temperature to be measured. The appearance of dew on the metal mirror changes the reflected light flow. This change has influence on the amplifier and consequently on the dc current of the Peltier element. As soon as the dew point is formed, we can measure the dew-point temperature. The setting time of the measuring device is only a few seconds. A dew-point hygrometer using a Peltier element can also be used for aggressive and other condensing gases (11).

LiCl Hygrometer. The sensing medium, which is a hygroscopic salt (LiCl), absorbs water from the air. An electrical voltage is applied across the salt, and a current passes according to the amount of water vapor

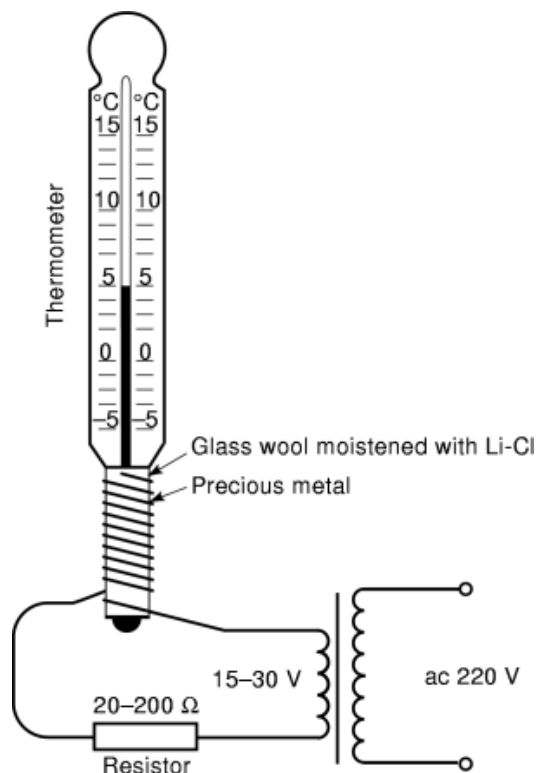

Fig. 7. LiCl dew-point hygrometer.

that has been absorbed. The insulating tube is covered with a glass wool and then coiled up with a wire in the shape of a double screw (see Fig. 7). The wire warms the thermometer placed inside the tube. The glass wool is moistened with LiCl, which also contains water molecules. The current running through the conducting moistened glass wool warms the coil. This causes the lowering of the glass wool conductivity (due to water evaporation), until the partial pressure of water vapor does not exceed the equilibrium point. The temperature of the thermometer, too, exceeds the equilibrium temperature. The reduction of water in LiCl salt reduces the glass wool conductivity and the thermometer warming. Consequently, the temperature of the thermometer falls, LiCl absorbs the humidity again, the conductivity increases, and as a result a higher current is once more obtained. This current again warms the coil and thus reduces the humidity in the LiCl salt. This process repeats until the equilibrium dew point is achieved. The temperature at which this occurs is related to the water vapor pressure. The measuring range is -20°C to $+60^{\circ}\text{C}$ (dew-point temperature). Long-term stability is within $\pm 0.5^{\circ}\text{C}$ to 1°C of the dew-point temperature. The electrical power used for this process is 1 W. The setting time is approximately 1 minute (1,2,3). The instrument is usually in probe form, with reading displayed in terms of dew point.

Conversion Between Dew Point and Relative Humidity. There is no simple direct formula for converting in either direction between dew point and relative humidity. Conversion between these two parameters must be carried out via the intermediate step of evaluating both the actual vapor pressure of water and the saturation vapor pressure at the prevailing temperature. Values of relative humidity or dew point can then be calculated using the appropriate formula above. Table 2 shows values of relative humidity at selected temperatures and dew points.

Table 2. Values of Relative Humidity at a Selection of Temperature and Dew Points (12,13)

Temperature: (°C)	0	5	10	15	20	25	30	35	40	50	60	70	80	90	100
Dew Point (°C)	Relative Humidity (%)														
0	100	70.1	49.8	35.8	26.1	19.3	14.4	10.9	8.3	4.9	3.1	2.0	1.3	<1	<1
5		100	71.1	51.1	37.3	27.5	20.5	15.5	11.8	7.1	4.4	2.8	1.8	1.2	<1
10			100	72.0	52.5	38.7	28.9	21.8	16.6	9.9	6.2	3.9	2.6	1.7	1.2
15				100	72.9	53.8	40.2	30.3	23.1	13.8	8.6	5.5	3.6	2.4	1.7
20					100	73.8	51.1	41.6	31.7	18.9	11.7	7.5	4.9	3.3	2.3
25						100	74.6	56.3	42.9	25.7	15.9	10.2	6.7	4.5	3.1
30							100	75.4	57.5	34.3	21.3	13.7	9.0	6.1	4.2
35								100	76.2	45.6	28.2	18.0	11.9	8.0	5.6
40									100	59.8	37.0	23.7	15.6	10.5	7.3
50										100	61.9	39.6	26.1	17.6	12.2
60											100	63.9	42.1	28.4	19.7
70												100	65.8	44.5	30.8
80													100	67.6	46.8
90														100	69.2

Table 2 gives relative humidity as a function of the dew-point depression t_d for several values of the dew point. This table is used to estimate relative humidities between the values listed; the uncertainty may be up to $\pm 1\%$ or $\pm 2\%$. Small differences in air pressure within the normal atmospheric range will affect these figures by less than 0.1% relative humidity (*rh*) (10,14).

Impedance-Type Hygrometers

This general type of sensor is fabricated from a hygroscopic material, the electrical properties are altered as it absorbs water molecules. Changes in humidity are measured as changes in the sensor’s electrical capacitance or resistance or some combination of the two. The majority of modern impedance sensors use thin-film technology. Impedance hygrometers are usually also fitted with temperature sensors. Readings are displayed directly, sometimes with a choice of units (e.g., relative humidity or dew point), and output of an electrical signal may also be available (15). There are several distinct types of electrical sensors.

Capacitive Sensors. Capacitive sensors respond most closely to relative humidity, rather than dew point, with best linearity at low relative humidities. Figure 8 shows the capacitive sensor for measuring humidity. It consists of a perforated housing inside of which there is a thin hygroscopic film layer coated with gold. This thin film layer represents acts as a dielectric for the capacitor. Under the influence of humid air, the dielectric constant of the thin film layer and consequently the capacitance of the capacitor change, as can be seen in Fig. 9. With the help of a simple measuring circuit we obtain the change of the voltage, which depends on the relative humidity (16).

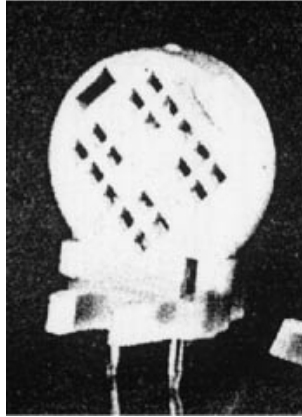

Fig. 8. Capacitive sensor for humidity measurement.

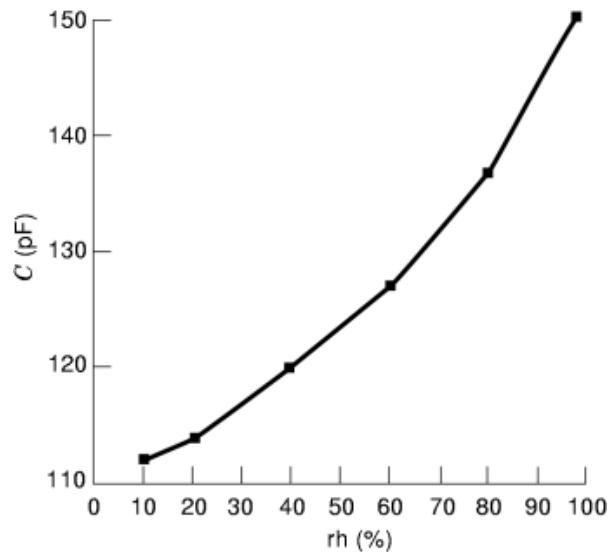

Fig. 9. The dependence of sensor capacitance on the relative humidity.

Resistive Sensors. Resistive sensors correspond most closely to relative humidity hygrometers, rather than to dew point hygrometers. The linearity of resistive sensors is best at high humidities. Most resistive sensors cannot tolerate condensation. However, some are “saturation guarded,” with automatic heating to prevent condensation. Figure 10 shows the humidity characteristic of devices at 40°C for various mole ratios of $\text{TiO}_2/\text{SnO}_2$. The mixture in mole ratio of $\text{TiO}_2:\text{SnO}_2 = 2.9:1, 1.9:1, 1:1, \text{ or } 0.5:1$ was sintered at 1200°C for 2 h with Ta_2O_5 (several mole %). The results indicate that the electrical resistance of the device in any mole ratio decreases exponentially with an increase in rh, and the increase in mole ratio of $\text{TiO}_2/\text{SnO}_2$ causes an increase in the whole device resistance and moisture-sensitivity (17).

Dew-Point Type Impedance Sensors. Dew-point type impedance sensors are a special case of impedance hygrometer, used to measure in absolute units rather than relative humidity. Following a similar general principle, the sensor may feature aluminum oxide or other metal oxides, or a silicon base for the

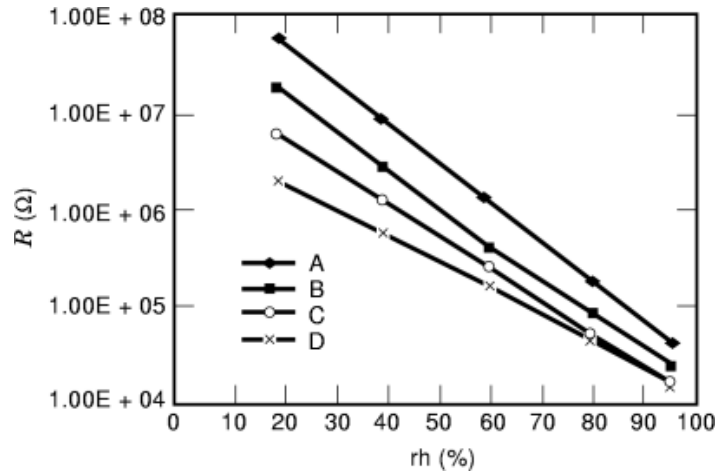

Fig. 10. Humidity characteristics of the thick film resistive sensor for various molar ratios of $\text{TiO}_2/\text{SnO}_2$ (curves A, B, C, and D correspond to 2.9:1, 1.9:1, 1:1, and 0.5:1, respectively).

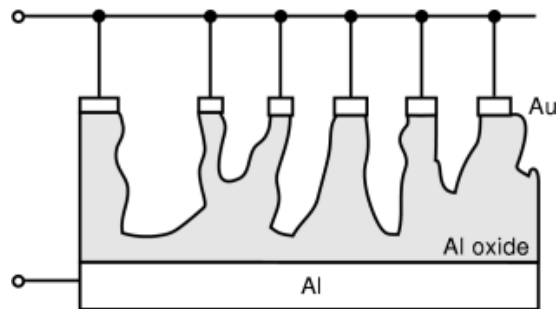

Fig. 11. Cross section of an Al_2O_3 sensor.

active element. This type of sensor responds to the partial pressure of water vapor. Commonly the signal is converted into other absolute units, resulting in values displayed by the instrument in dew point or parts per million by volume. These sensors can have a wide range of measurement, including very dry gases. They are often used at high pressure, or to sample gas originating from the system at high pressure (15). Figure 11 shows the change of impedance in an Al_2O_3 sensor. The latter consists of an aluminum plate having a surface of 4 mm^2 onto which first a thin layer of aluminum oxide and then a gold film are deposited. The absorption of water molecules which pass through the $0.3 \mu\text{m}$ thick gold layer to the pores of aluminum oxide depends on the partial pressure of water vapor. Consequently the resistance and the capacitance of the aluminum oxide change. Figure 12 shows the equivalent electrical circuit of an Al_2O_3 sensor shown in Fig. 11 (18).

Resistive and capacitive sensors are used for a variety of applications in ambient conditions, including control of air conditioning and other processes. Some are used in more extreme environments. “Dew-point” types are distinct from others in this group in that they cover much lower levels of humidity, in absolute units, and are used in the control and monitoring of relatively dry gases. They include aluminum oxides and other metal oxides, and silicon-based sensors. Relative humidity types can achieve uncertainties of 2% to 3% of value, at best, while dew-point types have uncertainties of around 2°C in dew point, at best, to 5°C at low dew points (15).

14 HYGROMETERS

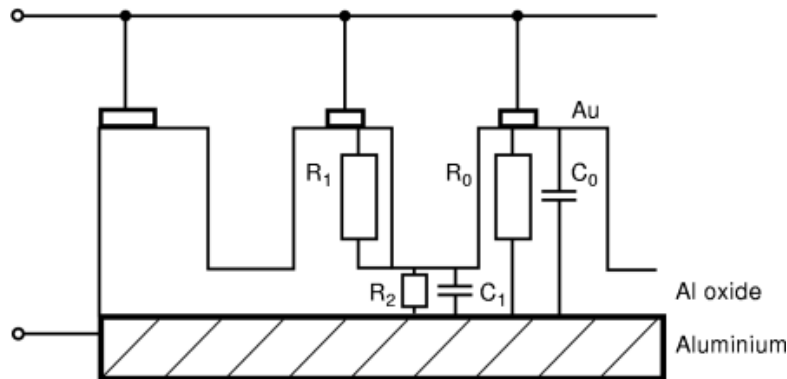

Fig. 12. Schematic view of the electrical circuit equivalent to the Al_2O_3 sensor.

Advantages(+) and disadvantages(-) of these sensors include the following:
Capacitive sensors in particular

- + Usually tolerate condensation (though calibration may shift)

Resistive sensors in particular

- May be damaged if condensation occurs (though some sensors are protected)

Dew-point impedance sensors in particular

- + Usually tolerate condensation (though calibration may shift)
- + Can have wide measuring range
- May be slow to settle at very low (absolute) humidity
- Have some tendency to drift

Piezoelectric Hygrometers

Humidity-gas sensors have been developed using AT-cut quartz-crystal resonators vibrating in the thickness-shear mode. The sensing element is a radio-frequency quartz crystal coated with a hygroscopic polymer material. In a simple circuit using such a crystal, the frequency of oscillation decreases when the crystal gains weight due to water absorption by the coating. Since frequency changes can be measured accurately and rapidly, this results in an accurate and simple moisture analyzer. In a SAW device a surface acoustic wave is electrically excited in a piezoelectric single-crystal plate substrate (e.g., quartz, lithium niobate, lithium tantalate) by use of a metallic (e.g., aluminum) interdigital transducer (*IDT*) structure. It is also possible to use the quartz crystal as a stable oscillation element whose substitutional electrical structure only is being changed through the variation of the serial capacitance. The sensor probe C_x is an open capacitor (having the form of a comb).

Coated Quartz-Crystal Humidity Sensor. While a coated quartz-crystal resonator is vibrating in ambient air (assuming only one surface is in contact with the ambient air), it can be simplified as a three-layer model. Figure 13 shows such a model, where layer I consists of the quartz crystal (including the lower electrode), layer II consist of the upper electrode and absorbent/absorbate materials that can be regarded as solid phase, and layer III is a pure fluid layer where shear vibration will be damped rapidly (19).

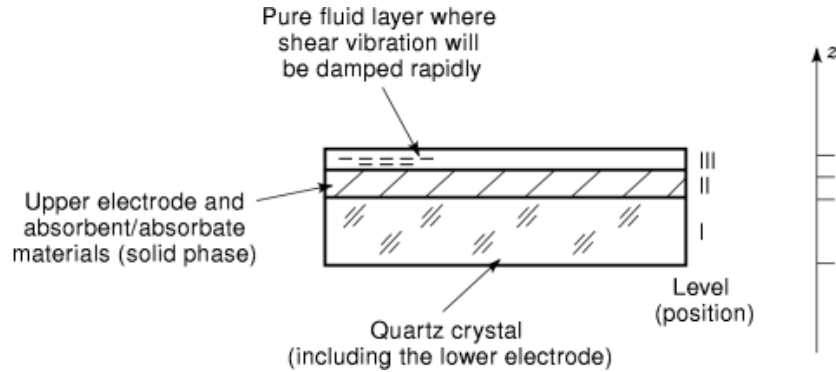

Fig. 13. Three-layer model.

The principle is mainly based upon Sauerbrey's formula (20,21):

$$\Delta f = \frac{-2\Delta m n f_0^2}{A(\mu_q \phi_q)^{1/2}} \quad (6)$$

where Δm = mass of substances absorbed on the surface, Δf = shift of frequency, ϕ_q = density, μ_q = shear modulus, A = surface, $m = 1$ (when the effect of generalized viscosity of layer III can be neglected).

When the resonant frequency f_0 is 3.5 MHz, the frequency change between 20% and 95% humidity is approximately 1000 Hz. Typical data obtained by an instrument using this principle of measurement are as follows: range: 0.1 to 33,000 ppm; speed: 99% dry-down in one minute; minimum detectable: ± 0.1 ppm; selectivity: hydrogen, hydrocarbons, olefins, alcohols, acid gases, and chlorinated solvent vapors cause only negligible interference.

SAW Resonator for Absolute Humidity Measurement. The frequency range covered starts at about 50 MHz and ends up at a few gigahertz, corresponding to a state-of-the-art interdigital finger linewidth below $0.5 \mu\text{m}$ (22). Because many parameters may contribute to a frequency change of the SAW device, the reverse determination of a parameter change from a measured frequency change is ambiguous. The most common solution of the problem is the use of two equal devices, where only one of the devices is coated with a layer that produces a known unique sensitivity to the measured gas (e.g., analytic concentration), while the other device is used as a reference element as in Fig. 14. The difference of the frequency changes of both devices is only sensitive to the measured gas, with the frequency changes caused by all other influences being compensated by this difference principle.

The SAW sensor is a 200 MHz two-port resonator fabricated on ST-cut quartz with aluminum metallization. The interdigital transducers were designed with split fingers apodized for narrow bandwidth. They are coated with a radio-frequency 20 nm thick sputtered with silicon dioxide layer as the sensing film. The coated SAW resonator and the reference resonator are fabricated on separate substrates. Responses of the coated SAW sensor to water vapor provide shifts in SAW resonator frequencies using modulation circuits. The frequency shift which is caused by the change of humidity from 1 to 6 g/m^3 is approximately 500 Hz (23).

The absolute humidity of water-vapor density ρ_w in saturated moist air is given by the following equation (24):

$$\rho_w = \frac{18.0152f(P,T)e_w(T)}{V_m P} \times 10^6 \text{gm}^{-3} \quad (7)$$

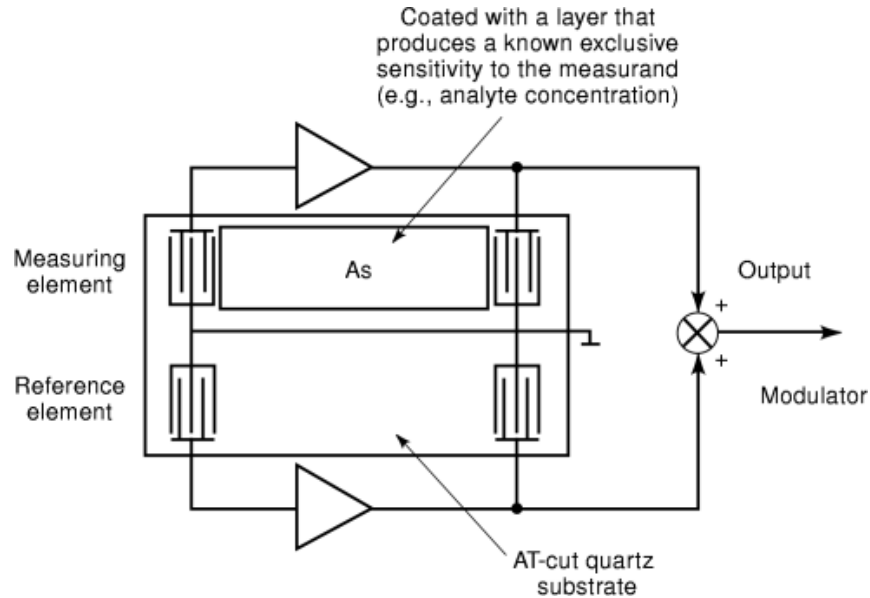

Fig. 14. SAW sensor using the difference principle.

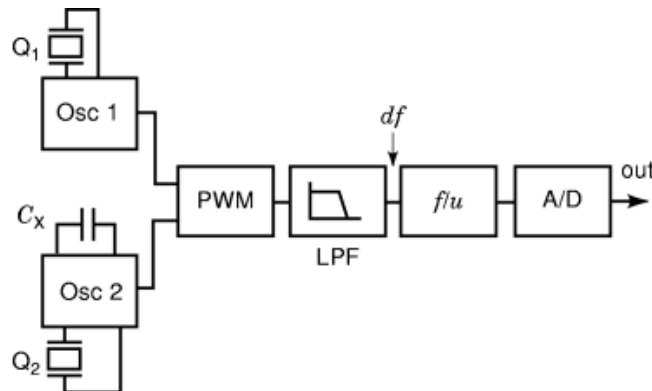

Fig. 15. Hygrometer using the sensitive capacitive dependent crystals.

where V_m is the molar volume of the moist air, P is the total pressure, $e_w(T)$ is the saturation water-vapor pressure at the absolute temperature T , and $f(P,T)$ is the enhancement factor. The molar volume, V_m , is obtained by solving the equation of state for moist air as described in Ref. 23. In the range of water-vapor density from 1 to 30 g m^{-3} , the estimated maximum relative uncertainty is 0.1%.

The Piezoelectric Hygrometer Using Sensitive Capacitive-Dependent Crystals. The frequencies of oscillator 1 and oscillator 2 of the sensor depicted in Fig. 15 are 18 MHz. The output of the pulse-width modulator (PWM) is a pulse-width signal which is compensated for temperature and voltage drift (Fig. 15) (24).

The sensor probe C_x is an open capacitor (having the form of a comb) (Fig. 16). The distance between the open capacitor plates (C_x) is 0.3 mm. The sensor probe is formed on an Al_2O_3 basis together with electronics and

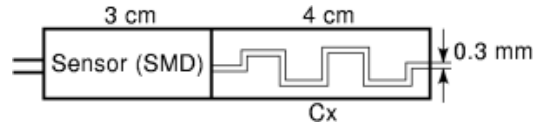

Fig. 16. Sensor probe Cx.

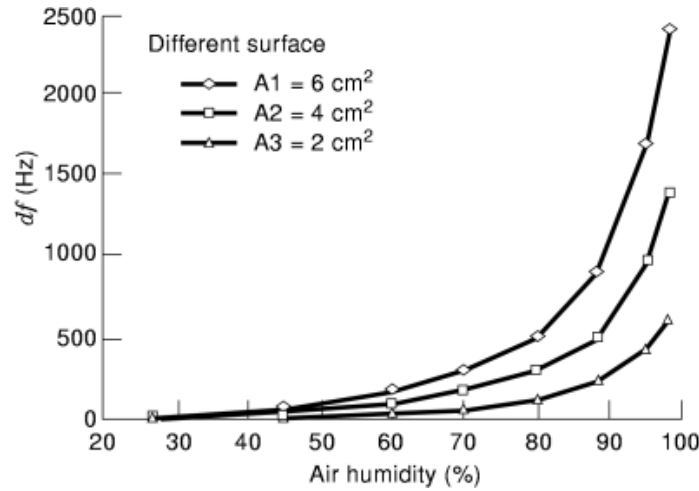

Fig. 17. Air-humidity measurement.

a temperature-sensing element. The crystal is used as a stable oscillation element whose electrical structure only is being changed through the variation of the serial capacitance C_x .

The humidity measurement is determined by Eq. (8). (K = constant depending on mechanical realization).

$$\Delta f = K^{\text{humidity}} \quad (8)$$

The sensor probe [open capacitor in the form of a comb which does not charge itself statically (Fig. 16)] has the surface $A1(C_{x1} = 9 \text{ pF})$, $A2(C_{x2} = 6 \text{ pF})$, $A3(C_{x3} = 3 \text{ pF})$ (Fig. 17).

The frequency measurement uncertainty is $\pm 0.1 \text{ Hz}$. The fact that the capacitor does not charge itself statically gives this method the advantage over the others. The typical uncertainty of high-air-humidity measurements is about $\pm 2.5\%$ ($T = 15$ to 25°C and humidity = 50 to 98%); however, this sensor presented has an improved uncertainty of $\pm 0.1\%$. The fact that the sensor is not made of absorption materials that can be affected by dust ensures long-term repeatability even after calibration. (Sensor probe is the only open capacitor.)

Electrolytic Hygrometers

There are two basic methods of electrolytic hygrometer: The first method is based on the measurement of conductivity and the second uses phosphorous pentoxide. The basis of the conductivity method represents the measurement of conductivity of electrolytic hygroscopic material (Fig. 18). The electric current flowing through the hygroscopic material causes the ionization of water molecules in the electrolyte which results in ionic conductivity. The second method uses phosphorous pentoxide, which absorbs humidity from the air.

18 HYGROMETERS

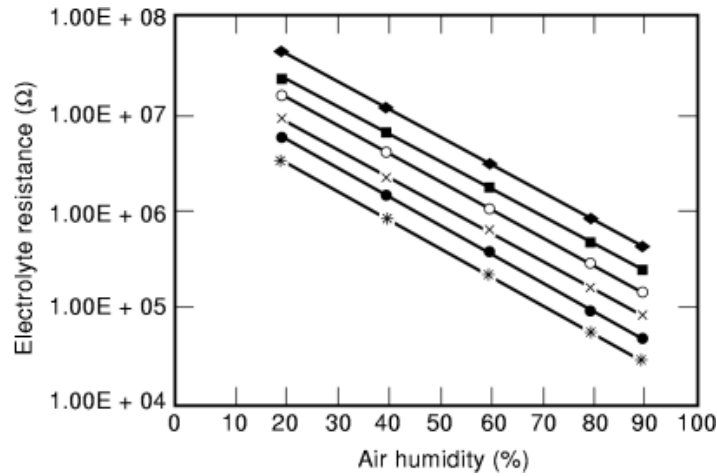

Fig. 18. Temperature and resistance characteristics of an electrolytic hygrometer. The temperature rises from the lowest curve to the highest ones.

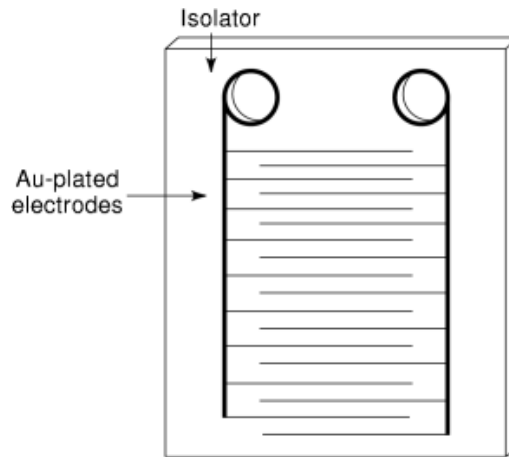

Fig. 19. Electrolytic probe. Gold plated electrodes covered with either porous textile or cotton wool or glass wool or porous ceramic.

Method Based on the Measurement of Conductivity. The rate of humidity absorbed from the air affects the electric conductivity of hygroscopic material. The voltage applied is alternating due to polarization.

Figure 19 shows gold-plated electrodes covered with either porous textile or cotton wool or glass wool or porous ceramics. The uncertainty of the humidity measurement is $\pm 3\%$ (25,26) (Fig. 20).

Electrolytic Hygrometer Using Phosphorus Pentoxide. The sensor consists of a film of powerful desiccant, phosphorus pentoxide (P_2O_5), which strongly absorbs water vapor from the surrounding gas. A voltage is applied across the P_2O_5 and electrolysis takes place, dissociating the water into its constituents, namely, hydrogen and oxygen. The current that flows in this process is related (by Faraday's Law) (27) to the amount of water electrolyzed. Thus the magnitude of the current indicates the humidity of the gas being measured. These sensors are suitable for measuring very low humidities, though they require a steady (known) flow rate of gas. They are normally used in flow sampling configurations, rather than in probe form (27). In

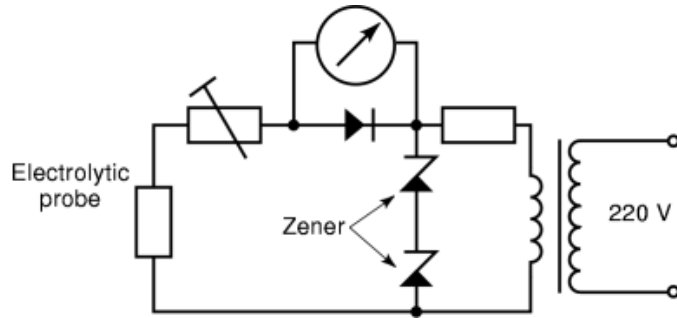

Fig. 20. Humidity measurement based on conductivity method.

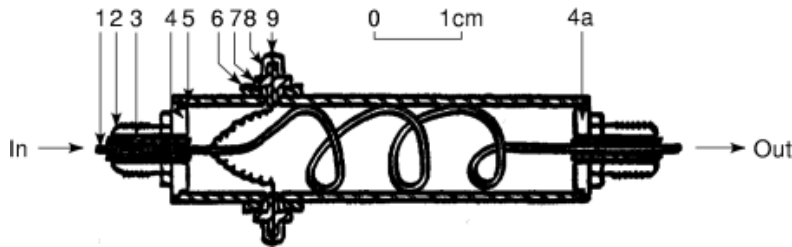

Fig. 21. Cross section of detector. 1, Inlet end of sensitive element; 2, Fluon bush; 3, 6.35 mm male flare union brazed to part No. 4; 4 and 4a, brass end pieces; 5, brass tube filled with Seekay wax R93C; 6, boss brazed to brass tube; 7, Tufnol bush secured with Araldite; 8, metal cap secured with Araldite; 9, electrode soldered to metal cap.

the electrolytic hygrometer the gaseous sample flows at a steady rate (conveniently 100 mL/min) through a polytetrafluorethylene (PTFE) tube about 76 cm long and with a 0.7 mm bore. Inside the tube are two interlaced but separate helical electrodes of fine platinum wire. The electrodes are covered with a thin film of partially hydrated phosphorus pentoxide, and a voltage of about 70 V dc is maintained between them. The sensitive element (which is flexible) is coiled and potted in Seekay wax (chloronaphthalene wax) in a 1.905 cm bore brass tube 10.16 cm long (Fig. 21) and provided with connections for the gas supply with the terminals of the electrical circuits (28).

The principle of this method is that an equilibrium is set up (often within a few minutes) between the rate of absorption of water and the rate of electrolysis of the absorbed water. For a gas flowing at 100 mL/min at 20°C and 100 kPa (760 mm Hg), the equilibrium current is 13.4 μA per part per million by volume of water vapor (28). Since the equilibrium current I is proportional to both the water content W and the sample flow rate R , the water content in ppm v/v at 20°C and 100 kPa is given by

$$W = \frac{100 I}{13.4 R} \tag{9}$$

where I is in microamperes and R is in milliliters per minute.

In some cases (e.g., Arcton 6) the film does not absorb all the water from the sample; the water content can then be obtained by the absorption efficiency of the detector for the particular gas being used. A method of determining the efficiency is described later. Equation (9), which is applicable to any gas, is used throughout this article. In the refrigeration industry, however, water contents are usually specified as a proportion by weight; the conversion factor for Arcton 6 is 1 ppm w/w = 6.7 ppm v/v .

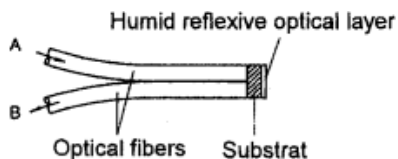

Fig. 22. Optical fiber hygrometer.

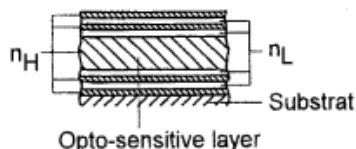

Fig. 23. Multilayer structure.

This is a long established method for use in dry environments. The uncertainty is ± 3 to $\pm 10\%$ of reading at best (29). (+ advantages, – disadvantages)

- + Compatible with some corrosive gases
- + Can have good sensitivity
- Measuring cells have a limited life, after which they must be recoated (and recalibrated)
- Flow rate of gas is critical
- Damaged by exposure to normal ambient humidities and by periods of extremes of dryness (below 1 ppm)
- Slow response at lowest humidities
- Hydrocarbons, butadiene, ammonia, and some other contaminants prevent proper operation
- Adds traces of hydrogen and oxygen to the gas sample, which can recombine, leading to errors

Optical Fiber Hygrometers

The optical fiber hygrometer is a sensor consisting of two optical fibers. One end of these two fibers is attached to the humid reflexive optical system as shown in Fig. 22. The other two ends are connected to the light source and attached to the optospectral measuring device and polychromator. Fibers are used only for the transmission of light (30).

The humidity sensing element is a multilayer system with good measuring reflective spectrum (Fig. 23). This is a Dünuschicht-Fabry-Perot interference filter, which consists of several consecutive high and low refractive dielectric $\lambda/4$ layers. The optical efficiency of the thickness of a single layer as a product of the geometric thickness and optical refraction of light (n_L for low and n_H for high refractive layers) needs to be set to the medium working light source wavelength λ . The polychromator has to be adjusted to that wavelength as well. The multilayer system consists of 8 dielectric $\lambda/4$ layers with low and 10 layers with high refractive index. The reflexive minimum is situated near 800 nm working wave range. All layers together are approximately 2 μm thick. SiO_2 with low refractive index and TiO_2 , ZrO_2 or HfO_2 with high refractive index are used as dielectric material. They are temperature stable and their chemical resistance is known. A more or less large structure of pores depends on the degree of evaporation in vacuum (30).

In humid environments water molecules can be reversibly sorbed. The optical refractive index of layers is changed and the reflexive spectrum is shifted towards longer wavelengths. The shift reversibly depends on the

partial pressure of water vapor. The volume of different size pores and their probable distribution determine the functional course of the spectrum shift. To achieve the wanted porous structure, technological parameters of certain layers need to be preset. The final sensitivity depends on the optical resolution of the polychromator.

The Sensor's Measuring Range. The sensor's porous structure is designed to measure the dew-point temperature in the range from +10 up to -100°C . It is interesting to note that the temperature above 300°C does not destroy the sensor. In such case the sensor only needs a regeneration time and a new calibration. The dew also does not damage the sensor. Once the latter is dry again, it is like newly calibrated.

The optical fiber sensor has the following advantages:

- it is very small ($\phi < 1 \text{ mm}$)
- it can be more than 100 m away from the measuring electronics
- the measuring results are not influenced by electromagnetic disturbances, capacitance and inductance between the conductors, parallel resistance
- it can work in an explosive environment
- it is temperature and corrosive stable
- it works up to 100°C
- it has a short reaction time (5 s)

Calibration

Calibration is the process of comparing a measuring instrument with a fixed reference for the same type of measurement, to identify any bias or systematic error in the readings. The outcome of a calibration is normally a certificate listing any corrections that need to be applied to the values indicated by the instrument, together with an estimate of the uncertainty in the calibration, and other relevant information. For example, a calibration of a given instrument at, say, 50% rh, might show it to read too high by 1% rh. If so, a required correction of -1% rh would be shown on the certificate.

Humidity Generation. The main methods of humidity generation are as follows (12):

Dew-Point Generator Gas is humidified by bubbling it through (or flowing it over) water or ice at a given temperature. Depending on the efficiency of the design, this will produce gas with a dew point more or less close to the temperature of the saturator.

Two-Temperature Generator Gas is humidified at a given temperature, defining its dew point, or vapor pressure. The gas is then fed to a chamber at another (higher) temperature. By varying one or both temperatures, it is possible to obtain any chosen value of relative humidity or dew point.

Two-Pressure Generator Gas is humidified at elevated pressure and then expanded to a lower pressure (at the same temperature). As the total pressure of the gas falls, so does the partial pressure of water vapor. Knowing the initial humidity allows the humidity after expansion to be found. By varying the initial pressure or temperature or both, it is possible to obtain any chosen value of relative humidity or flow dew point.

Mixed Generator Gas is humidified by any convenient method and is then mixed with drier gas. The value of humidity achieved depends on the mixing proportions and on the water content of the two gas streams.

Salts Saturated (or unsaturated) salt solutions, and certain other chemicals, can be used to generate an environment of a particular relative humidity in an enclosed space. The value of relative humidity obtained depends on the particular chemical salt, the concentration of the solution, and the temperature of use, among other things.

22 HYGROMETERS

Humidity Chambers Test chambers are available with both temperature and humidity control based on steam or spray injection, or on one of the principles outlined above.

Bottled Gases Cylinders of compressed gas are available which supply gas of fixed humidity, at a selection of values of a few hundred ppm or below. The method relies on a special coating of the cylinder interior.

Used appropriately, any of the above methods can provide a stable humidity for use in comparing one hygrometer with another, already calibrated, one. This may mean supplying a flow of gas to pass through both instruments to be compared, or placing both instruments in a chamber where they are exposed to the same humidity. Humidity generators can be calibrated, but only at national standard level are they accurate and authoritative enough to act as absolute references.

Calibration Using Salt Solutions. Salt solutions generate characteristic values of relative humidity which depend on the particular chemical salt, the concentration of the solution, and the temperature of use. Saturated salt solutions, with solid salt present, have the special property that a stable concentration—and hence a constant relative humidity—is maintained even if water migrates to or from the solution. Ready-made capsules are commercially available for a variety of relative humidity “fixed points.” Such capsules are designed to seal over the end of relative humidity probes, providing a small enclosed atmosphere of defined relative humidity. Certain of these, if in the form of a solution with a solid salt present, are reusable and can be calibrated to assign a traceable value to the reference humidity they provide.

Table 3 shows values of humidity generated over saturated solutions of various salts (13,31). Just as it is for relative humidity in general, temperature stability is critical for calibration with salt solutions, particularly since the properties of the salt solutions change with temperature (Table 3, Fig. 24). Stabilization after a change in temperature may take an hour, or many hours, depending on the size of the change. For freshly mixed solutions, full stabilization may take a long time, sometimes weeks (31,32).

Some Practical Recommendations for Calibration of Hygrometers. Hygrometers should be calibrated in terms of the quantity to be measured. For example, the performance of a wet- and dry-bulb hygrometer cannot be characterized by calibrating the thermometers alone; a humidity calibration of the hygrometer as a whole is needed. Where a hygrometer consists of separate parts (e.g., probe and electronics) the pair should be calibrated together as one item and used together. Wherever possible, calibrations should be performed under the intended conditions of use—that is, at similar values of humidity and temperature, and preferably under similar conditions of pressure, air flow, and so on. Hygrometer readings in some units of measurement (such as grams per cubic meter) are specific to gas type. Therefore a calibration in these units is valid only for a selected gas. This is so because the ratio of molecular masses of water and air, for instance, is about 0.62, whereas the ratio for methane is about 1.1. However, calibrations in terms of (say) parts per million by volume are not necessarily gas-specific, or only very slightly so (provided the instrument genuinely senses this quantity and does not simply give a numerically converted result from some other parameter) (33).

A general guideline for calibrating the various types of hygrometers might be as follows:

- Hygrometer types with relatively good stability (e.g., condensation dew-point hygrometers, wet- and dry-bulb hygrometers): 6 to 12 months after first calibration; thereafter every 1 to 12 years, depending on requirements.
- Moderately stable hygrometer types (e.g., electrical relative humidity instruments): perhaps 6 months after first calibration; thereafter every 6 to 12 months, depending on requirements.
- Less stable hygrometer types (e.g., aluminum oxide hygrometer) every 6 months, or sooner if desired.

Where a choice of intervals is suggested above, the longer intervals are for hygrometers confined to use in ordinary room or laboratory conditions, whereas the shorter intervals are for those used in more varied conditions. If used in extreme conditions or if accuracy is critical, then measurement checks of some kind at

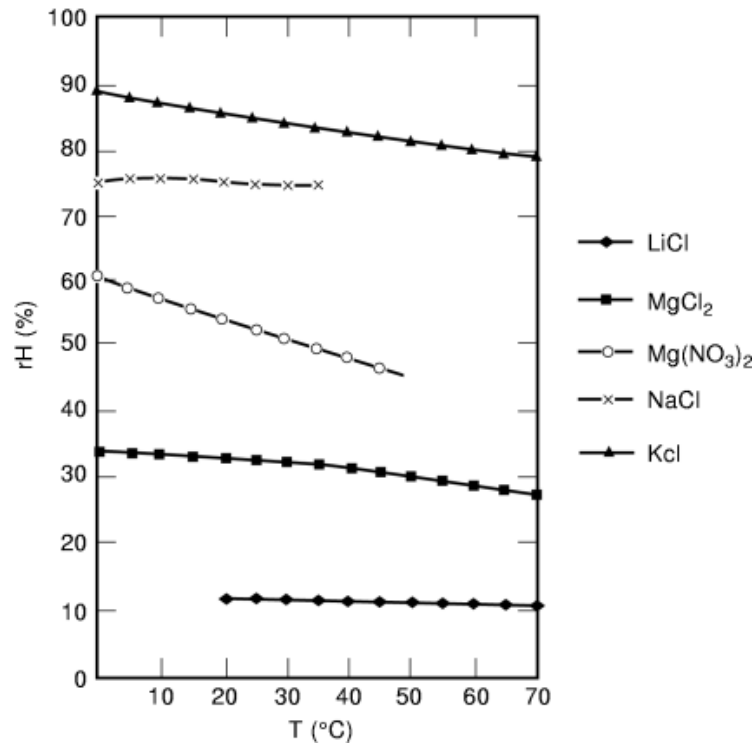

Fig. 24. Temperature stability of salt solutions.

much shorter intervals are recommended. Where hygrometers are strongly prone to drift, this will remain a significant source of uncertainty almost irrespective of the frequency of calibrations.

Long-Term Stability

The measurement characteristics of an instrument will change with respect to time, due to gradual changes in its electrical or material components. Estimates of long-term stability, or drift, refer to the likely change in the instrument's measurement performance with respect to time. Regular checks of calibration should be made to quantify this problem. Although sometimes adjustments can be made to the hygrometer reading in the light of drift, performance could be compromised by the adjustment process, and the overall drift characteristics could be masked by frequent adjustments (34,35).

Speaking about the measurement characteristics of hygrometers, we also have to take into consideration the following terms:

Uncertainty. The uncertainty of a measurement is defined as the parameter characterizing the range in which the "true value" can be expected to lie. It defines a "margin of doubt" about a reading or estimated value, together with a level of confidence (normally 95%) that the "true value" will lie within this range. Often, the uncertainty for an instrument is specified for ideal operating conditions at a temperature of 20°C or 23°C. The method of use may make an important contribution to the overall uncertainty achieved.

Accuracy. Strictly speaking "accuracy" is a qualitative term only. For example, an instrument or measurement might be described generally as "accurate" or "not accurate." However, the word "accuracy" continues

Table 3. Standard Salt Solution for Humidity Calibration

Temperature (°C)	LiCl	MgCl ₂	Mg(NO ₃) ₂	NaCl	KCL
0		33.66 ± 0.33	60.35 ± 0.55	75.51 ± 0.34	88.61 ± 0.53
5		33.60 ± 0.28	58.86 ± 0.43	75.65 ± 0.27	87.67 ± 0.45
10		33.47 ± 0.24	57.36 ± 0.33	75.67 ± 0.22	86.77 ± 0.39
15		33.30 ± 0.21	55.87 ± 0.27	75.61 ± 0.18	85.92 ± 0.33
20	11.31 ± 0.31	33.07 ± 0.18	54.38 ± 0.23	75.47 ± 0.14	85.11 ± 0.29
25	11.30 ± 0.27	32.78 ± 0.16	52.89 ± 0.22	75.29 ± 0.12	84.34 ± 0.26
30	11.28 ± 0.24	32.44 ± 0.14	51.40 ± 0.24	75.09 ± 0.11	83.62 ± 0.25
35	11.25 ± 0.22	32.05 ± 0.13	49.91 ± 0.29	74.87 ± 0.12	82.95 ± 0.25
40	11.21 ± 0.21	31.60 ± 0.13	48.42 ± 0.37		82.32 ± 0.25
45	11.16 ± 0.21	31.10 ± 0.13	46.93 ± 0.47		81.74 ± 0.28
50	11.10 ± 0.22	30.54 ± 0.14	45.44 ± 0.60		81.20 ± 0.31
55	11.03 ± 0.23	29.93 ± 0.16			80.70 ± 0.35
60	10.95 ± 0.26	29.26 ± 0.18			80.25 ± 0.41
65	10.86 ± 0.29	28.54 ± 0.21			79.85 ± 0.48
70	10.75 ± 0.33	27.77 ± 0.25			79.49 ± 0.57
75	10.64 ± 0.38	26.94 ± 0.29			79.17 ± 0.66
80	10.51 ± 0.44	26.05 ± 0.34			78.90 ± 0.77

to be used loosely in specifications to refer to the maximum difference that can be expected between the reading given by an instrument and the “true value” being measured.

Repeatability. In general terms, the repeatability of an instrument is the closeness of agreement of multiple readings repeated under the same conditions of measurement. To quantify repeatability, the spread or dispersion of results may be quoted, for example, in terms of a standard deviation of a number of readings.

Reproducibility. In general terms, reproducibility is an instrument’s capacity to reproduce a previous measurement. This may be at a later date or after undergoing significant changes in conditions, for example, after a change of operator or location. To quantify reproducibility, the spread or dispersion of results may be quoted, for example, in terms of a standard deviation of a number of readings.

Temperature Influence on the Stability of Relative Humidity Measurement. Relative humidity is highly dependent on temperature. Roughly speaking, at room temperature, a change in dew point of 1°C corresponds to a change in relative humidity of 6% of the relative humidity value. At 50% rh, for example, an uncertainty in dew point of ±1°C corresponds to an uncertainty of ±3% rh. A change of 1°C in the measurement of the ambient temperature has almost exactly the same significance. The size of the effect under different conditions is illustrated in Table 4.

Overall, a useful rule of thumb is that ±1°C uncertainty in either dew point or temperature leads to an uncertainty of ±6% of the relative humidity value. The change in the relative humidity levels is not symmetric (36,37,38).

Table 4. Effect of a Temperature Change of 1 °C at Various Levels of Temperature and Relative Humidity

Relative Humidity	Temperature				
	10 °C	20 °C	30 °C	50 °C	70 °C
10% rh	±0.7% rh	±0.6% rh	±0.6% rh	±0.5% rh	±0.5% rh
50% rh	±3.5% rh	±3.2% rh	±3.0% rh	±2.6% rh	±2.3% rh
90% rh	±6.3% rh	±5.7% rh	±5.4% rh	±4.6% rh	±4.1% rh

BIBLIOGRAPHY

1. D. M. Considine G. Considine *Process Instruments and Controls Handbook*, 3rd ed., New York: McGraw-Hill, 1985.
2. The Institute of Measurement and Control, *A Guide to the Measurement of Humidity*, London: Crown, 1996, pp. 21–54.
3. E. R. Schramek Psychrometer. In *Taschenbuch für Heizung und Klimatechnik*, Munich: Oldenbourg, 1997, pp. 305–307.
4. W. Lück Psychrometer, In *Feuchtigkeit*, Munich: Oldenbourg, 1964, pp. 104–119.
5. D. R. Lide Relative humidity from wet and dry bulb temperatures. In *CRC Handbook of Chemistry and Physics*, 77th ed., Boca Raton, FL: CRC Press, 1996–1997, pp. 15–22.
6. W. Lück Die Wasseraufnahme der Stoffe. In *Feuchtigkeit*, Munich: Oldenbourg, 1964, pp. 48–56.
7. H. Kiessig W. Koblitz *Der Anteil an Adsorptionswasser bei der Quellung von Cellulosefasern*, Papier 13, H. 15/16, 1959, p. 356.
8. F. Kollmann Eine Gleichung der Sorptionsisotherme, *Naturwissenschaften*, **49**: 206–207, 1962.
9. T. Seiyama Development and application of ceramic humidity sensors. In *Chemical Sensor Technology*, Vol. 1, Amsterdam: Elsevier, 1988, pp. 57–61.
10. The Institute of Measurement and Control, *A Guide to the Measurement of Humidity*, London: Crown, 1996, pp. 41–53.
11. W. Lück Sättigungsverfahren. In *Feuchtigkeit*, Munich: Oldenbourg, 1994, pp. 74–98.
12. The Institute of Measurement and Control, *A Guide to the Measurement of Humidity*, London: Crown, 1996, pp. 30–31.
13. D. R. Lide Standard salt solutions for humidity calibration. In *CRC Handbook of Chemistry and Physics*, 77th ed., Boca Raton, FL: CRC Press, 1996–1997, pp. 15–24.
14. D. R. Lide Values of relative humidity at a selection of temperature and dew points. In *CRC Handbook of Chemistry and Physics*, 77th ed., Boca Raton, FL: CRC Press, 1996–1997, pp. 15–23.
15. The Institute of Measurement and Control, *A Guide to the Measurement of Humidity*, London: Crown, 1996, pp. 14–25.
16. Valvo Sensoren in *Feuchtesensor*, Herausgeber: Valvo Unternehmens-Bereich Bauelemente der Philips GMBH, Burcharostraze 19, 2000 Hamburg 1, 1980, pp. 48–52.
17. T. Seiyama Humidity sensor using TiO₂-SnO₂ Ceramics. In *Chemical Sensor Technology*, Vol. 2, Amsterdam: Elsevier, 1989, pp. 133–149.
18. H. Fischer K. Heber Impedanzveränderung eines Dünnschicht-Aluminium-Oxide. In *Industrielle Feuchtigkeitsmesstechnik*, Ehningen, Germany: Expert Verlag, 1990, pp. 42–44.
19. Y. Dong G. Feng Effect of surface physical sorption on characteristic of coated quartz-crystal humidity sensor, *Sensors and Actuators*, **B24-25**: 62–64, 1994.
20. A. Wexler W. H. King The piezoelectric sorption hygrometer. In *Humidity and Moisture*, Vol. 1, New York: Elsevier, 1965, pp. 578–583.
21. E. Benes *et al.* Sensors based on piezoelectric resonators, *Sensors and Actuators*, **A48**: 1–22, 1995.
22. D. Hauden S. Rousseau J. Gagnepain Sensitivities of SAW-oscillators to temperature, forces and pressure: Application to sensor. In *Proc. 34th Annu. Frequency Control Symposium*, Philadelphia, 1980, pp. 735–743.
23. P. H. Huang Sensor calibration of a SAW resonator for absolute humidity measurement in microelectronic packages, *Sensors and Actuators*, **B24-25**: 686–688, 1995.
24. V. Matko D. Donlagic Sensor for high-air-humidity measurement, *IEEE Trans. Instrum. Meas.*, **45**: 561–564, 1996.
25. W. Lück Elektrolytisches Hygrometer. In *Feuchtigkeit*, Munich: Oldenbourg, 1964, pp. 129–135.

26 HYGROMETERS

26. T. Seiyama Design of polymer electrolytes-based humidity sensors. In *Chemical Sensor Technology*, Vol. 1, Amsterdam: Elsevier, 1988, pp. 117–132.
27. The Institute of Measurement and Control, *A Guide to the Measurement of Humidity*, London: Crown, 1996, pp. 15–23.
28. J. K. Crawshaw Electrolytic hygrometers for measurements in gases down to a few parts per million, *J. Sci. Instrum.* **36**: 121–126, 1959.
29. H. Fischer K. Heber Verfahren der Feuchtemessung. In *Industrielle Feuchtigkeitsmesstechnik*, Ehningen, Germany: Expert Verlag, 1990, pp. 19–59.
30. A. Böhm G. Schwotzer Faseroptische Feuchtemessung, *Sensortechnik*, Heft 10, 13. May, 1997, pp. 48–51.
31. DIN 50 008, Kontaktklimate über wässrigen Lösungen (Gesättigte Salzlösungen-Glycerin Lösungen), Deutsche Normen, 1981.
32. W. Lück Die relative Luftfeuchte über wässrigen Lösungen. In *Feuchtigkeit*, Munich: Oldenbourg, 1964, pp. 56–59.
33. J. Pichlmaier *Befeuchtung von Prüfgas für die Kalibrierung von Gas- und Feuchtesensoren*, Technisches Messen 58/12, Munich: Oldenbourg, 1991, pp. 471–477.
34. The Institute of Measurement and Control, *A Guide to the Measurement of Humidity*, London: Crown, 1996, pp. 45–52.
35. W. Lück Psychrometer. In *Feuchtigkeit*, Munich: Oldenbourg, 1964, pp. 104–119.
36. Rotronic AG, *Feuchtemessung in Luft, Feuchte und Temperaturmessung*, Bassersdorf, Germany, 1996–1997, p. 146.
37. H. Fischer K. Heber Messgenauigkeiten für Gasfeuchte. In *Industrielle Feuchtigkeitsmesstechnik*, Ehningen, Germany: Expert Verlag, 1990, pp. 26–59.
38. P. Profos T. Pfeifer Die Luftfeuchtemessverfahren. In *Handbuch der industriellen Messtechnik*, Munich: Oldenbourg, 1992, pp. 821–824.

VOJKO MATKO
University of Maribor